

HITACHI SUMITOMO

SCX2800-2

HYDRAULIC CRAWLER CRANE

Specifications

EUROPEAN ISSUE



Specifications

HITACHI SUMITOMO

SCX2800-2

Superstructure

UPPER REVOLVING FRAME:

All-welded, precision machined, robust construction. A machined surface provided for mounting load hoist and boom hoist assemblies, and mounting itself on turntable bearing. And pins bail frame with a 12-sheave machinery and single center sheave of a 21.0 D/d ratio for 2×12-part boom hoist reeving.

TURNTABLE BEARING WITH INTERNAL SWING GEAR:

Heavy duty, single shear ball type; inner race of turntable bearing with integral, internal swing (ring) gear bolted to carbody frame, and outer race of turntable bearing bolted to upper revolving frame.

CONTROL SYSTEM:

System contains two sets of triplicate tandem valves which direct oil to various machine function and are actuated by control levers via remote controlled hydraulic servo for all motions. Working speeds can be precisely controlled by pilot-operated universal joystick and armchair single axis control levers in cooperation with "EPC" controller that varies engine rpm and hyd. pump discharge simultaneously thru engine foot throttle control, or varies just hyd. pump discharge while keeping engine rpm. via pump discharge dial control. System also takes a specially-tailored unique hydraulic circuit to maximizes drum horsepower, and reduces horsepower loss with eliminating the possibility of engine stall.

Pump control system — By "EPC" controller that provides two modes of engine-pump control.

MODE I:

The "EPC" Controller is normally programmed to vary the engine speed and pump discharge simultaneously. Simply pedaling the foot throttle advances the engine to maximum speed and the hydraulic pumps to maximum flow at the same time. This mode is suitable to precision crane work.

MODE II:

By activating a pump discharge control dial located at instrument panel, it is able to vary just the pump discharge while keeping engine speed fixed. Mode II is convenient for operations such as lifting magnet and bucket work, where the engine is normally run at full throttle.

A specially-tailored pressure compensating valve — Utilized in hydraulic circuits to realize a good minute operation of two main, boom hoist and opt. luffing jib hoist drums.

HYDRAULIC SYSTEM:

System provided with three variable displacement axial piston pumps and one fixed displacement duplicate tandem gear pump for both independent and combined operations of all functions. Gear pump also used for system valves and cylinder controls.

Main/aux. crane hoist motors — Variable displacement axial piston motor with counterbalance valve and spring-applied/hydraulically released multiple wet-disc type automatic brake as std.

Boom hoist motor — Variable displacement axial piston type with counterbalance valve and spring-applied/hydraulically released multiple wet-disc type automatic brake.

Luffing jib hoist drum motor — Optional extra; axial piston type with counterbalance valve and

spring-applied/hydraulically released multiple wet-disc type automatic brake; available for luffing jib hoisting/lowering.

Swing motor — Two; axial piston type with spring-applied/hydraulically released multiple wet-disc type brake; electrically controlled from instrument panel of operator's cab.

Travel motors — Shoe-in design; axial piston motor with brake valve and spring-applied/hydraulically released multiple wet-disc type automatic brake.

Oil cooler — Aluminum-make; located at a part of superstructure as separated from engine radiator together with an independent autocooling fan for better cooling efficiency and heat balance.

Hydraulic oil reservoir — 450 liters capacity.

Kind of hyd. oil — Standardized with ISO VG46 having viscosity ranging from 41.4 thru 50.6mm²/sec at 40°C.

LOAD HOIST ASSEMBLY (w/out free-fall function):

Std.; front and rear main operating drums driven by independent hydraulic motor of bi-directional, variable displacement axial piston motor through 2-stage planetary reduction gear units powering the rope drum in either direction for hoisting and lowering load. Both of drums size in same dimension.

Brakes — Spring-applied, power hadraulically released multiple wet-dise type automatic brake; provided within hyd. motor.

Drums — One piece, parallel grooved lagging with locking ratchet wheel cast integral; involute-splined to the reduction gear unit shaft which is mounted on anti-friction bearing. Available to wind up 51m long cable of 28mm dia. at drum 1st layer.

Drum locks — Electrically controlled pawl.

Drum rollers — Optional extra; available for right cable winding onto drums.

Drum rotation speed control — Max. rotation speed can be tuned according to arbitrary value that is electrically controlled by dialing, and then varies pump discharge. Available on two main operating drums independently.

Motor swash plate angle setting switch — Available to set motor swash plates of front/rear drum winch motors at a certain angle for easily synchronizing front and rear drum rotation speeds.

LOAD HOIST ASSEMBLY (w/free-fall function):

Optional extra; front and rear main operating drums driven by independent hydraulic motor of bi-directional, variable displacement axial piston motor through a 2-stage planetary reduction gear unit powering the rope drum in either direction for hoisting and lowering load. Reduction gear unit installed within drum inside together with multiple wet-disc brake unit. Both of drums size in same dimension.

Brakes — Multiple wet-disc unit with negative brake design that takes the function of "spring-applied, power hydraulically released", and maintains a high brake safety even if a hydraulic pressure drop in the circuit happens; installed within drum inside together with shaft-coupled reduction gear unit. Eliminate clutch, and require no brake maintenance on this brake design.

Brake control — Applies dynamic hydraulic pressure for brake release operation with an extreme light pedaling force.

Brake mode — Available in two modes; one is automatic as suitable for liftcrane operation, and the other is free-fall mode as suitable for bucket operation. Free-fall interlocking is also designed for fail-safe operation.

A forced-oil cooling system — Available in both front and rear drum brake units to keep brake

performance even in continuous heavy-duty operations.

Drum rotation speed control — Max. rotation speed can be tuned according to arbitrary value that is electrically controlled by dialing, and then varies pump discharge. Available on two main operating drums independently.

Motor swash plate angle setting switch — Available to set motor swash plates of front/rear drum winch motors at a certain angle for easily synchronizing front and rear drum rotation speeds.

Drums — One piece, parallel grooved lagging with locking ratchet wheel cast integral; bolted to reduction gear unit. Available to wind up 51m long cable of 28mm dia. at drum 1st layer.

Drum locks — Electrically operated pawl.

Drum rollers — Optional extra; available for right cable winding onto drums.

BOOM HOIST ASSEMBLY:

Twin-drum design; driven by single bi-directional, axial piston hydraulic motor through a 3-stage planetary reduction gear unit powering the rope drum in either direction for hoisting and lowering boom.

Brake — Spring-applied, power hydraulically released multiple wet-disc type automatic brake.

Drum — One piece, twin-design, parallel grooved lagging with locking ratchet wheel cast integral; bolted to planetary reduction gear unit outer case.

Drum lock — Power hydraulically operated automatic pawl.

Drum rotation speed control — Max. rotation speed can be tuned according to arbitrary value that is electrically controlled by dialing, and then varies pump discharge.

LUFFING JIB HOIST DRUM WINCH MECHANISM:

Optional extra; driven by bi-directional, axial piston hydraulic motor through 2-stage planetary reduction gear unit powering the rope drum in either direction for hoisting and lowering luffing jib; required when front drum is used for liftwork with tower head top sheave machinery. Mounted on boom bottom section.

Brake — Spring-applied, power hydraulically released multiple wet-disc type automatic brake; provided within hydraulic motor.

Drum — One piece, parallel grooved lagging with locking ratchet wheel cast integral; bolted to planetary reduction gear unit outer case.

Drum lock — Power hydraulically operated automatic pawl.

Drum rotation speed control — Max. rotation speed can be tuned according to arbitrary value that is electrically controlled by dialing, and then varies pump discharge.

SWING:

Driven by two units of bi-directional, axial piston hydraulic motors through 2 sets of planetary reduction gear unit powering swing pinion. Swing pinion meshes with internal teeth of swing (ring) gear of turntable bearing inner race.

Brakes — Spring-applied, power hydraulically released multiple wet-disc type; provided on each of hydraulic motor.

Swing speed control — Max. swing speed can be tuned according to arbitrary value that is electrically controlled by dialing, and then varies pump discharge.

Lock — Mechanically operated drop pin.

Speed — 1.5min.⁻¹ <1.5rpm>

OPERATOR'S CAB:

A 2.3mm thickness steel plate construction with 940mm wide and a stamped-and-

rounded corner designs; acoustically treated, full-vision, cushion rubber mounted, well-ventilated, full compartment, roomy operator's cab with a large straightened front window with green-tinted safety glass; provided with an arrangement of control station with universal joystick and armchair control levers, sunvisor, sunshade, rear-view mirrors, dual intermittent type window shield wipers with washer on both front and roof windows, sliding windows on both sides of cab, and swing-link type sliding door.

Swing-away mechanism — Provided as standard; available to set a 3-meter overall width of superstructure for a good transport.

Tilting mechanism — Power hydraulically tiltable cab is standardized for a good upward visibility.

Instrument panel — Contains engine monitoring lamps, graphic display panel of Load Moment Indicator, gauges & meter, warning lamps and other necessary controllers and switches.

Operator's seat — Full adjustable reclining seat with head rest and both R/H and L/H side arm rests.

Air-conditioner — Provided as std.; built-in type full air-conditioning.

Electric cab fan — Optional extra; wind-direction adjustable type.

Anemometer — Optional extra; recommended for luffing jib attachment.

Engine foot throttle — Available for right-hand foot control, and links "EPC" controller electrically.

Electric outlet — 24V; available in cab.

Operator's cab sidestep — Available for access ease to operator's cab.

AM/FM radio — Provided as std. with clock.

Fire extinguisher — Optional extra; powder type with 1kg capacity.

Drum brake pedals — Optional extra; correspondingly designed in the case that an optional free-fail function is required on two main operating drums.

MACHINERY CAB:

Equipped with hinged doors on both sides for machinery access and inspection; affixed tape-type non-skid material on the roof.

CATWALKS:

Optional extra; hitched in place along both sides of machinery cab.

HYDRAULIC TAGLINE WINDER:

Optional extra; provided in front of upper revolving frame, and this is available for preventing a shake of suspended load like clamshell bucket by an 10mm dia. tug cable with light force.

COUNTERWEIGHTS:

Weighs 102.8ton consisting of a 22.4ton base weight and a 12-piece cast iron block of 80.4ton in its total.

Counterweight self-removal device — Provided as std.; raises and lowers a 102.8ton full counterweight by a lifting mechanism with two power hyd. cylinders attached on the base weight.

ELECTRICAL SYSTEM:

24-volt negative ground system; provided with two maintenance free 12-volt batteries.

LIGHTING SYSTEM:

Includes following lights.

- Two 70 W working lights;
- One 10 W interior cab light.

POWER UNIT:

Make & Model	Mitsubishi 6M70-TL
Type	Water-cooled, 4-cycle, direct injection, turbo-charged, diesel w/automatic cooling fan
No. of Cylinders	Six (6)
Bore & Stroke	130 mm × 150 mm
Displacement	12,880 cc
Rated Output	272 kW/2,000 min ⁻¹ (370 ps/2,000 rpm)
Maximum Torque	1,510 N·m/1,600 min ⁻¹ (154 kgf·m/1,600 rpm)
Fuel Tank	500 liters

Notes:

1. The engine meets Stage/Tier 3 of current smoke emission regulations in Europe, America and Japan.
2. A 272kW engine horsepower shown above is defined under a current international engine horsepower indication formula which includes necessary horsepower for engine alternator drive but excludes engine fan drive.

A PORTABLE ENGINE-HYDRAULIC POWER PACK:

Optional extra; available to supply power hydraulic to hydraulic cylinders as used as rear post backstops. Required when luffing jib att.

Undercarriage

CARBODY FRAME:

All-welded, precision machined, box type construction; provided with four tip blocks w/pins and lugs to hook and then assemble crawler side frames on. To mount turntable bearing, a machined surface is provided too.

Hyd. removal joint-pins — Four; available to hold in place crawler side frames on carbody frame with a face-contact design to bear reaction force of crawler side frame. And, four pins are each operated by hyd. cylinder thru remote control box shown in clause of "CARBODY JACK-UP DEVISCE" below.

CARBODY JACK-UP DEVICE:

Contains four hydraulic jack cylinders attached on carbody jack cylinder beams for disassembling/assembling ease of crawler side frames.

Remote control box — Provided for control of carbody jack cylinders and hyd. removal joint-pins.

Pontoon — All-welded construction; four pontoons each attached on outside of carbody weight.

CRAWLER SIDE FRAMES:

All-welded, box type construction, precision machined; each provided with two steel plate hooks for an assembling ease on carbody

frame. Held in place by hydraulic removal heavy duty joint-pins provided on four tip blocks of carbody frame.

Crawler side steps — Provided at both ends of the frames for easy access to superstructure.

CARBODY WEIGHT:

Weighs 18ton; made of cast iron. A 9ton each mounted on carbody jack cylinder beams provided at front and rear of the carbody.

DRIVE SPROCKETS:

Cast steel, heat treated; one per side frame. Track drive sprocket assembly bolt-coupled to 3-stage planetary reduction gear unit outer case as an integral part of shoe-in type traction motor. Sealed between parts of rotation and non-rotation of the motor with floating seal.

IDLER WHEELS:

Cast steel, heat treated; one per side frame. Mounted on two bronze bushings with floating seals for lifetime lubrication.

TRACK ROLLERS:

Thirteen per side frame; each heat treated cast steel with double flange design. All rollers mounted on two bronze bushings with floating seals for lifetime lubrication.

CARRIER ROLLERS:

Three per side frame; each heat treated cast steel with double flang design. All rollers mounted on bronze bushings with floating seals for lifetime lubrication.

TRACKS:

Heat treated, self-cleaning, multiple hinged track shoes joined by full floating pins; 58 pcs. per side frame.

Shoe width — 1,120mm wide as standard.

Track adjustment — Manual adjustment device with oil jack and shim plate packs is standardized.

Automatic track tension adjusting device — Optional extra; available instead of std. track adjustment to always keep track tension at optimum level by means of power hyd. cylinder thru idler wheel actuated by power hydraulic supplied from superstructure.

TRAVEL AND STEERING:

A bi-directional, shoe-in type axial piston hydraulic motor bolt-couples drive sprocket thru 3-stage planetary reduction gear unit outer case at each crawler side frame end for travel and steer. Straight-line travel (forward or reverse), pivot or differential turns, and counter-rotation for spin turns are available.

Brake — Spring-applied, hydraulically released multiple wet-disc type automatic brake; located within hydraulic motor. Brakes automatically set when travel levers are in neutral or when engine is shut down.

Travel speed — 1.1/0.5km/hr. (based on flat, level and firm supporting surface, and under the conditions that no load must be applied and front-end att. must be 15.25m basic boom only).

Gradeability — 30% (17°) permissible based on basic machine without front-end attachment.

Safety Devices

LOAD MOMENT INDICATOR:

This is a fully computerized automatic over-load preventing system including total safe operation control system and meets both of EN and BS Standards; provided with the designs of (1) no zero-point adjustment, (2) data input according to interface counter-indication/message on display panel, and (3) a graphic display panel with setting ease of viewing angle.

Construction (standard version) — Comprises (1) load detecting device with amplifier, (2) boom angle detector, (3) computerized Micro Processing Unit (M.P.U.), and (4) graphic display panel.

Functions — This system functions that if the lifting load reaches 90% of the rated one specified in the crane capacity chart, an intermittent pre-warning buzzer is given; if it is 100%, a warning is given by a continuous buzzer, and all peril side motions are automatically stopped. The machine, however, can be operated in safety side motions.

Display panel design — A graphic display panel is designed, and it is able to input necessary operating conditions/data according to interface counter-indication/message on the display panel, and the display panel indicates ten and some kinds of the present lifting and working conditions/data like "lifting load", "max. allowable lifting load", "working radius", "max. allowable working radius", "boom angle", "load ratio", "boom/jib lengths", "engine rpm" and so on when working. In addition, the display panel is provided with three warning indicators over "engine over-heat", "hyd. oil over-temp." and "brake oil over-temp."

DRUM ROPE OVER-PAYOUT PREVENING DEVICE:

Available on both front and rear main drums, and functions to automatically stop drum rotation when no. of rope winding at 1st layer becomes three(3).

HOOK OVER-HOIST LIMITING DEVICE:

Limit switch type. Available to prevent hook over-hoisting with functions of automatic drum braking with hydraulic lock, and warnings by an alarm.

BOOM OVER-HOIST AND -LOWERING LIMITING DEVICE:

Available in two kinds of devices; one is limit switch located on a part of boom foot for preventing boom over-hoisting, and the other is the safety function of the LMI available to automatically prevent boom over-hoisting and -lowering with the functions of automatic drum braking with hydraulic lock, and warnings by an alarm. Further boom protection from rapid boom over-hoist by hook over-hoist motion under mal-function of hook over-hoist limiting device is available as one of functions of the LMI.

BOOM BACKSTOPS:

Dual; telescopic design with spring buffers.

DUAL BOOM OVER-HOIST LIMITING DEVICE:

Additional limit switch located on boom backstops; this is a further safety device for redundant boom protection.

SWING LOCK:

Mechanically operated drop pin; available to firmly lock superstructure in four positions of facing front or rear or left or right to undercarriage.

DRUM LOCKS:

Electrically operated pawl locks is available on front and rear main drums while power hydraulically operated pawl lock is available on boom hoist drum with an automatic locking device as std.

FREE-FALL INTERLOCKING DEVICE:

Available on both front and rear main drum brake lines for fail-safe operation. Functions that free-fall brake mode is only available when drum brake pedal is pressed even though brake mode is switched on free-fall mode.

SWING BRAKE SAFETY CIRCUIT:

Available not to start engine whenever swing brake is off.

NON-DRUM BRAKE PREVENTING DEVICE:

Available not to start engine whenever drum brake mode is in "free-fall".

BOOM ANGLE INDICATOR:

Pendulum type; mounted on right-hand side of bottom section of crane main boom.

HOOK LATCH:

Provided on every kinds of hook to prevent out of place of cable from hook.

LEVEL GAUGE:

Bubble type; located on operator's cab floor and a part of undercarriage.

LEVER LOCKS:

Provided on two armchair control levers for travel to lock levers in neutral.

SWING ALARM:

This is by buzzer, and flasher lamps located on both sides of machinery cab.

SPEED SLOWDOWN DEVICE:

This is for speed slowdown of hoisting and lowering motions of boom which are available just before automatic stopping at both upper and lower side limits of boom angle even though control lever(s) is still at hoisting/lowering position to prevent a shock.

SWING BRAKE LAMP:

Provided on operator's cab instrument panel; this is available to confirm whether or not swing brake is applied.

SIGNAL HORN:

Available as warning just before every kinds of motions are initiated.

FOOL PROOF SHUT-OFF SYSTEM:

Located in the cab exit; this is available to automatically deactivate and lock hydraulic system.

TRAVEL ALARM:

An intermittent buzzer warns when travel motion is initiated.

ENGINE MONITORING LAMPS:

Available to let operator warn engine abnormal conditions as to battery charge, lubrication oil

pressure, radiator coolant level, oil filter clogging, air filter clogging, water temp., control unit and glow plug.; provided on instrument panel.

FRONT-END ATT. ERECTION MODE:

This is an internal, integral function of the LMI. In the range out of crane working area, the LMI display panel automatically indicates "Now, out of crane working range" with a rigging instruction, and it is available to lift front-end att. off ground without the influence of LMI safety functions, and, after front-end att. is lifted over the range of crane working area, LMI safety function gets back automatically for safe erection work. This function is also available for the work of vice-versa.

LIFTING HEIGHT METER:

Available to indicate lifting height above ground or depth below ground on display panel of the LMI. Also, hook hoisting speed slowdown function is available just before automatic stopping at a desired height under hook height setting before operation.

LMI SAFETY CIRCUIT-OFF SWITCH:

Available in key type for a good crane safety operation management without fail.

TRAVEL DIRECTION ARROW:

Attached each on crawler side frames.

GAUGES & METER:

Engine water temperature gauge, fuel gauge and hour-meter are provided on instrument panel.

WARNING LAMPS:

Available to let operator warn abnormal machine conditions as to pilot pressure and brake system of two main and opt. luffing jib hoist drums; provided on instrument panel.

REAR VIEW MIRRORS:

Two; each provided on front-left and -right corners of superstructure.

DRUM MIRROR:

Available to check rope winding onto front and rear drums from operator's cab.

THREE COLOR PERCENTAGE INDICATOR:

Optional extra; this is with three colours of Green, Yellow and Red. Each colour indicates the load percentage to rated capacity; Green shows less than 90% as safety, Yellow shows 90 to 99% as marginal, and Red shows over 100% as over-loading. As further function, Red lamp comes on automatically when operator cuts off safety circuit of LMI absent-mindedly.

MICROPHONE & LOUD-SPEAKER:

Optional extra; this is for operator's convenience for loud speaking.

DRUM LIGHT:

Optional extra; available for checking rope winding onto front and rear drums.

AUX. CRANE HOOK OVER-HOIST LIMITING DEVICE:

Optional extra; this is available for auxiliary crane hoist with optional aux. short jib and/or fly jib. Performs the same function as that of "Hook over-hoist limiting device" mentioned before.

In addition to the above, following safety devices are standard for luffing jib attachment.

LUFFING JIB ANGLE DETECTOR:

This is one of key safety device in a case of luffing jib attachment.

LUFFING JIB LOAD DETECTOR:

This is also important safety device when luffing towercrane attachment is required.

LUFFING JIB OVER-HOIST AND -LOWERING LIMITING DEVICE:

Performs all the same function as that of "Boom over-hoist and -lowering limiting device" stated before.

LUFFING JIB HOOK OVER-HOIST LIMITING DEVICE:

Performs the same function as that of "Hook over-hoist lifting device" described before.

LUFFING JIB BACKSTOPS:

Dual; telescopic design with spring buffers.

DUAL LUFFING JIB OVER-HOIST LIMITING DEVICE:

Additional limit switch located on tower jib backstops; this is as a further safety device for redundant tower jib protection.

LUFFING JIB HOIST DRUM LOCK:

Provided with automatic pawl-locking device like boom hoist drum pawl-locking (if luffing jib hoist drum is optionally provided).

REAR POST BACKSTOPS:

Two power hydraulic cylinders are designed to easily set rear post position as necessary when assembling front post and luffing jib; power hydraulic is supplied to these cylinders by a portable engine-hydraulic power pack.

Front-end Attachment

CRANE BOOM:

Lattice construction, round tubular main chords, alloy, hi-ten steel, with bracing of round steel tubing.

Boom connections.....In-line pin connections at 2.10m deep and 2.10m wide.

Basic boomTwo-piece, 15.24m basic length; 7.62m heavy-duty bottom and tapered top sections. Provided with boomfoot pin removal cylinders.

Boom head machinery.....Five head sheaves, and two guide sheaves mounted on anti-friction bearings of conventional non-sealed grease type.

Six-hanger sheave blockOptional extra; pinned to boom head shaft. Sheaves each mounted on anti-friction bearings of conventional non-sealed grease type. Required when lifting load exceeds 145ton, and available up to 275ton lift.

Five-hanger sheave block.....Optional extra; pinned to boom head shaft. Sheaves each mounted on anti-friction bearings of conventional non-sealed grease type. Required when lifting load exceeds 145ton, and available up to 250ton lift.

Ultra heavy-duty boom extensionsOptional extra; available in 3.05m, 6.10m and 12.20m with pendants.

Heavy-duty boom extensionOptional extra; available in 12.20m with pendants.

Maximum boom length.....91.45m meters.

Note: All of ultra heavy- and heavy-duty boom extensions are designed with no intermediate diagonal bracing(s); the diagonal bracing is only designed at one of two picture frames. Accordingly, it is able to nest luffing jib extension into appropriate boom extension in length.

FLY JIB:

Optional extra; lattice construction, round tubular main chords, alloy, hi-ten steel, with bracing of round steel tubing having in-line pin connections at 1.0m deep and 1.0m wide, and jib head machinery with single sheave mounted on anti-friction bearings of conventional non-grease type. Provided with jib strut, jib backstops, and jib/boom guyline pendants. Mounted on 7.62m tapered top section, and available for light load lifting operation with less than 25ton with two-part hoist line. Single part hoist line is also available for a 13.5ton lift as max.

Basic fly jibTwo-piece, 12.20m basic length; 6.10m bottom and top sections.

Fly jib extensionsAvailable in 6.10m length with pendants.

Maximum fly jib length36.55m.

Boom plus fly jib lengthMax. 70.1m + 36.55m.

AUXILIARY SHORT JIB:

Optional extra; all-welded construction having single sheave head machinery. Pinned to 7.62m tapered top section.

BOOM LIVE MAST:

A 7m long; all-welded, box construction. Mounted in front of upper revolving frame, and pins bridle frame with a 12-sheave machinery of a 21.0 D/d ratio for a 2x12-part boom hoist line. Raised by two power hyd. cylinders from transportation position to a certain working position as a short boom for self-assembling work as this mast is available to use for self-assembling of a whole machine without helper crane in cooperation with hydraulic counterweight self-removal device, and quick-draw power hydraulic cylinder with hook attached onto the mast. In addition, a 2-large diameter single pendant rope of short length with plate link is pinned on top of the mast for easy connection with a 2-dual extender cables.

MID-POINT SUSPENSION LINK:

Optional extra; required when boom length exceeds 88.40m.

HOOK BLOCKS:

- 275/145t, five sheaves plus 5-hanger sheave block with duplex type hook.....Optional extra.
- 250/145t, five sheaves plus 5-hanger sheave block with duplex type hook....Optional extra.
- 145t, five sheaves with duplex type hook(275t use).....Optional extra.
- 145t, five sheaves with duplex type hook(250t use).....Optional extra.
- 80t, three sheaves.....Optional extra.
- 35t, one sheave.....Optional extra.
- 13.5t, ball hook.....Optional extra.

Notes: An 145t hook block is each available from 250/275t hook block by dismounting a 5-hanger sheave block.

BAIL AND BRIDLE:

All-welded construction; provided with larger sheaves of a 21.0 D/d ratio on both bail and bridle for 2×12-part boom hoist rope reeving. Bail pinned to upper revolving frame directly, and bridle pinned to boom live mast respectively. And, pendant ropes bridge the gap between boom live mast and 7.62m tapered top section.

DRUM DATA:

Drum	Root dia.	Type	Line speed (Hoisting, Lowering)	Cable	Max. line pull
Front main	596mm	Parallel grooved	110 ~ 2mpm	28mm	245kN (25.0ton)
Rear main	596mm	Parallel grooved	110 ~ 2mpm	28mm	245kN (25.0ton)
Boom hoist	641mm	Parallel grooved	2 × (24 ~ 1.0)mpm	22.4mm	165kN (16.9ton) × 2
Luffing jib hoist (opt.)	596mm	Parallel grooved	55 ~ 2mpm	28mm	245kN (25.0ton)

Notes:

1. Line speed is based on drum first layer and rated engine rpm with no load.
2. Hoisting line speed varies under load and operating conditions.
3. Crane hoist applications of front and rear main drums shall be upon kind of front-end attachment.

HOIST REEVING:

(ton)

hook	No. of partline															
		21	19	16	14	12	10	9	8	7	6	5	4	3	2	1
275t	275.0	250.0	216.0	189.0	162.0	—	—	—	—	—	—	—	—	—	—	—
250t	—	250.0	216.0	189.0	162.0	—	—	—	—	—	—	—	—	—	—	—
145t	—	—	—	—	—	145.0	121.5	108.0	94.5	81.0	67.5	54.0	40.5	27.0	13.5	
80t	—	—	—	—	—	—	—	—	—	80.0	67.5	54.0	40.5	27.0	13.5	
35t	—	—	—	—	—	—	—	—	—	—	—	—	35.0	27.0	13.5	
13.5t	—	—	—	—	—	—	—	—	—	—	—	—	—	—	13.5	

CABLES:

- Front drumP-S (19)+39×P-7, non-spin type, 28mm dia./450m long, breaking load 755kN (77.0t).
- Rear drumOptional extra; P-S (19)+39×P-7, non-spin type, 28mm dia., breaking load 755kN (77.0t).
Length depends on crane hoist applications as under:
1. Fly jib application.....350m.
2. Aux. short jib application.....160m.
- Boom hoist drumXP rope with construction of IWRC 6×P-WS (31), 22.4mm dia./320m long, breaking load 417kN (42.5t).
- Luffing jib hoist drumOptional extra; XP rope with construction of IWRC 6×P-WS (31), 28mm dia./210m long, breaking load 657kN (67.0t).

Liftcrane Capacities 275 metric tons

Boom length (m) Working radius (m)	15.25	18.30	21.35	24.40	27.45	30.50	33.50	36.55	39.65	42.65	45.70	48.75	51.80	54.85	57.90	60.95	64.00
4.3	275.0																
4.5	269.4	243.0/4.8															
5.0	244.3	242.4	216.0/5.2														
5.5	223.5	223.3	215.1	215.2/5.7													
6.0	205.8	205.6	205.3	204.9	189.0/6.1	162.0/6.6											
7.0	177.6	177.3	177.0	176.6	176.3	162.0	148.5	135.0/7.5									
8.0	155.9	155.7	155.4	155.1	154.8	154.6	147.8	134.8	120.8	121.5/8.4	108.0/8.9						
9.0	138.8	138.6	138.3	138.0	137.6	136.8	132.8	130.5	119.8	121.5	108.0	94.5/9.3	93.2/9.8				
10.0	125.0	124.8	124.5	124.1	123.9	121.0	117.6	116.0	113.0	110.0	107.4	94.5	93.0	81.0/10.2	78.3/10.7	67.5/11.1	65.6/11.6
12.0	102.0	102.2	102.1	102.0	100.1	97.8	95.4	94.6	92.5	90.3	88.4	86.5	84.5	81.0	77.5	67.5	65.4
14.0	81.9	82.0	81.9	81.7	81.5	81.5	79.9	79.6	77.9	76.1	74.7	73.2	71.6	70.3	68.9	67.5	64.5
16.0	75.1/14.9	68.0	67.9	67.8	67.6	67.5	67.3	68.4	67.0	65.6	64.5	63.2	61.9	60.7	59.7	58.6	57.4
18.0		59.8/17.6	57.7	57.6	57.4	57.3	57.0	58.2	58.0	57.4	56.5	55.4	54.2	53.2	52.4	51.5	50.4
20.0			50.0	49.9	49.7	49.5	49.3	50.4	50.2	49.9	49.7	49.1	48.1	47.2	46.5	45.7	44.7
22.0			49.5/20.2	43.9	43.6	43.5	43.2	44.2	44.0	43.7	43.6	43.4	43.0	42.2	41.5	40.9	40.0
24.0				41.8/22.8	38.7	38.5	38.2	39.3	39.0	38.7	38.7	38.4	38.1	37.9	37.5	36.9	36.0
26.0					35.7/25.5	34.5	34.2	35.2	35.0	34.7	34.5	34.3	34.0	33.8	33.7	33.4	32.7
28.0						31.2	30.8	31.8	31.6	31.2	31.2	30.9	30.6	30.3	30.2	30.0	29.7
30.0						31.0/28.1	28.0	29.0	28.7	28.3	28.2	28.0	27.7	27.4	27.2	27.1	26.7
32.0							27.0/30.8	26.5	26.2	25.8	25.7	25.5	25.2	24.9	24.7	24.6	24.2
34.0								25.0/33.4	24.1	23.7	23.6	23.3	23.0	22.7	22.6	22.3	22.1
36.0									22.2	21.8	21.7	21.4	21.1	20.8	20.7	20.5	20.1
38.0										20.2	20.0	19.7	19.3	19.1	19.0	18.7	18.4
40.0										19.7/38.7	18.6	18.2	17.8	17.6	17.5	17.2	16.9
42.0											17.7/41.3	16.9	16.6	16.2	16.1	15.8	15.6
44.0												15.8	15.3	15.1	14.9	14.6	14.3
46.0													14.3	14.0	13.8	13.6	13.2
48.0													14.1/46.6	13.0	12.8	12.6	12.2
50.0														12.2	12.0	11.6	11.3
52.0															11.2/51.9	10.8	10.5
54.0																10.1	9.7
56.0																9.9/54.5	9.0
58.0																	8.6/57.2

Boom length (m) Working radius (m)	67.05	70.10	73.15	76.20	79.25	82.30	85.35	88.40	91.45
12.0	60.5	54.0/12.5	50.3/12.9	46.5/13.4	42.7/13.8				
14.0	59.7	54.0	50.0	46.2	42.5	38.3/14.3	34.2/14.7	30.4/15.2	27.0/15.6
16.0	56.2	53.1	49.2	45.6	42.0	37.2	33.4	29.9	26.8
18.0	49.3	48.7	47.7	44.5	40.9	35.9	32.3	28.8	25.8
20.0	43.7	43.2	42.3	41.4	39.2	34.4	30.9	27.7	24.8
22.0	39.1	38.7	37.9	37.0	36.2	32.7	29.6	26.4	23.6
24.0	35.2	34.9	34.0	33.3	32.5	31.0	28.2	25.2	22.5
26.0	31.9	31.6	30.8	30.2	29.4	29.2	27.1	24.1	21.5
28.0	29.0	28.7	28.0	27.3	26.7	26.5	25.6	23.0	20.5
30.0	26.4	26.2	25.6	25.0	24.2	24.2	23.5	22.1	19.5
32.0	23.8	23.9	23.4	22.8	22.2	22.1	21.5	20.7	18.6
34.0	21.7	21.7	21.3	20.9	20.2	20.2	19.6	19.0	17.8
36.0	19.7	19.7	19.4	19.1	18.6	18.6	18.0	17.3	16.7
38.0	18.1	18.1	17.7	17.3	17.0	17.1	16.5	15.8	15.3
40.0	16.5	16.6	16.2	15.8	15.5	15.6	15.1	14.5	14.0
42.0	15.1	15.1	14.8	14.5	14.1	14.2	13.8	13.3	12.8
44.0	14.0	14.0	13.6	13.3	12.8	13.0	12.6	12.1	11.6
46.0	12.8	12.8	12.5	12.1	11.8	11.8	11.5	11.1	10.6
48.0	11.8	11.8	11.5	11.1	10.8	10.8	10.5	10.1	9.7
50.0	10.9	10.9	10.5	10.2	9.8	9.9	9.6	9.1	8.8
52.0	10.1	10.1	9.6	9.3	9.0	9.1	8.7	8.3	8.0
54.0	9.3	9.3	8.9	8.6	8.2	8.3	8.0	7.5	7.2
56.0	8.6	8.6	8.2	7.9	7.5	7.5	7.2	6.8	6.5
58.0	8.0	7.9	7.5	7.2	6.8	6.9	6.5	6.1	5.8
60.0	7.4/59.8	7.3	6.9	6.6	6.2	6.3	5.9	5.5	5.1
62.0		6.8	6.4	6.0	5.6	5.7	5.4	4.9	4.6
64.0		6.7/62.4	5.8	5.5	5.1	5.1	4.8	4.4	4.0
66.0			5.6/65.1	5.0	4.6	4.6	4.3	3.9	3.5
68.0				4.7/67.7	4.1	4.2	3.9	3.4	3.0
70.0					3.7	3.7	3.4	3.0	2.5
72.0					3.7/70.4	3.4	3.0	2.5	2.0
74.0						3.2/73.0	2.6	2.2	1.6
76.0							2.3/75.6	1.8	1.2
78.0								1.5	
78.3								1.5	

▪ WORKING MASS & GROUND PRESSURE:

Shoe width	Mass	Pressure
1120mm	223.0t	124.0kPa <1.27kg/cm ² >

Note: Working mass shown above is with 15.24m basic boom, 102.8ton counterweight, 18ton carbody weight and optional 275t hook block.

Notes — Liftcrane capacities

1. Capacities included in these charts are the maximum allowable, and are based on machine standing level on firm supporting surface under ideal job conditions.
2. Capacities are in metric tons, and are rated in accordance with European EN13000 Standards in terms of machine stability and structural strength limitations; the figures surrounded by bold lines are based on factors other than those which would cause a tipping condition.
3. Capacities are based on freely suspended loads and make no allowance for such factors as the effect of wind, sudden stopping of loads, supporting surface conditions, and operating speeds. Operator must reduce load ratings to take such conditions into account. Deduction from rated capacities must be made for weight of hook block, weighted ball/hook, sling, spreader bar, or other suspended gear.
Hook block weight is as follows:
275t.....4.3ton 250t3.7ton
145t.....3.3ton (275t use)
145t.....2.7ton (250t use)
80t.....1.4ton 35t0.9ton 13.5t0.6ton
4. All capacities are rated for 360° swing.
5. Least stable rated condition is over the side.
6. An 102.8ton counterweight and 18.0ton carbody weight are required for all capacities on this chart.
7. Attachment must be erected and lowered over the ends of the crawler mounting.
8. Main boom length must not exceed 91.45m.
Maximum fly jib length permitted — 36.55m.
Maximum boom plus fly jib combination length permitted — 70.1m+36.55m.
Maximum boom length when mounting auxiliary short jib is 88.40m.
9. Capacities when handling load off main boom head sheaves in case of mounting fly jib or auxiliary short jib on top of boom are detailed; if required, please consult us or nearest distributor.
10. Boom combination shall be in accordance with manufacturer's standard described here in "Boom Combination Diagram" of page 16.

**SCX2800-2 AUXILIARY SHORT JIB CAPACITIES:
Max. 13.5ton**

Note: Jib capacities is almost equal to the figures made by the deduction of apporx. 600kg from the liftcrane capacities for boom length up to 88.40m unless restricted by the maximum jib capacity shown above. As to the details, please consult us or nearest distributor.

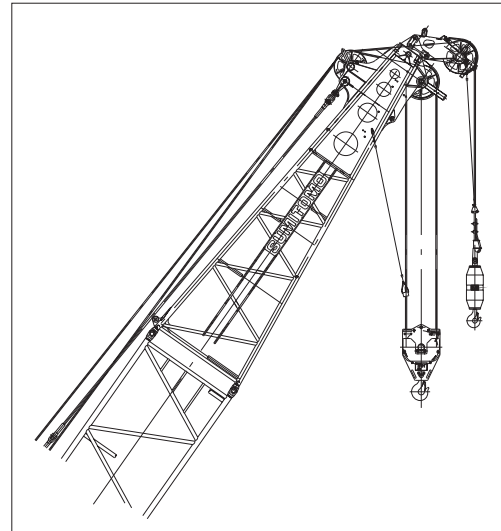

Auxiliary short jib (Option)

Boom length(m)	54.85									
Jib length(m)	12.20		18.30		24.40		30.50		36.55	
Jib offset angle(°)	10	30	10	30	10	30	10	30	10	30
Working radius(m)										
13.2	27.0/13.7	13.5/13.9								
14.0	27.0	13.5								
16.0	27.0	13.5	13.9/17.2	13.5/17.6	23.2	13.5				
18.0	27.0	13.5	13.8	13.5	22.6	13.5				
20.0	27.0	13.5	13.3	13.3	22.1	13.5	10.1/21.4	13.5		
22.0	27.0	13.5	12.8	12.8	21.6	13.5	10.0	13.5	11.8/19.7	
24.0	27.0	13.5	12.4	12.4	21.1	13.5	9.6	13.5	7.8/25.2	11.1
26.0	26.6	13.5	12.1	12.1	20.6	13.5	9.3	13.5	7.6	10.8
28.0	25.1	13.5	11.6	11.6	20.2	13.5	9.0	13.5	7.4	10.6
30.0	23.7	13.5	11.3	11.3	19.1	13.5	8.8	13.5	7.1	10.3
32.0	22.6	13.5	11.1	11.1	18.2	13.5	8.5	13.5	6.9	10.1
34.0	21.5	13.5	10.8	10.8	17.2	13.5	8.3	13.5	6.6	9.8
36.0	20.5	13.5	10.5	10.5	16.5	13.5	8.0	13.5	6.5	9.6
38.0	19.1	13.5	10.3	10.3	15.8	13.5	7.8	13.3	6.3	9.3
40.0	17.6	13.5	10.0	10.0	15.1	13.5	7.5	12.8	6.1	9.1
42.0	16.2	13.5	9.8	9.8	14.5	13.5	7.2	12.2	6.0	9.0
44.0	15.0	13.5	9.6	9.6	13.9	13.5	7.0	11.7	5.8	8.7
46.0	13.8	13.5	9.5	9.5	13.4	13.4	7.1	11.3	5.6	8.5
48.0	12.8	12.8	9.3	9.3	12.9	12.9	7.0	10.8	5.5	8.3
50.0	11.8	11.8	9.1	9.1	12.3	12.3	6.9	10.5	5.4	8.0
52.0	11.0	11.0	9.0	9.0	11.5	11.5	6.7	10.1	5.3	7.8
54.0	10.3	10.3	8.9	8.9	10.6	10.6	6.6	9.8	5.2	7.6
56.0	9.5	9.5	8.8	8.8	9.9	9.9	6.5	9.5	5.1	7.5
58.0	8.8	8.8	8.8	8.8	9.3	9.3	6.4	9.1	5.0	7.3
60.0	8.3	8.3	8.4	8.4	8.6	8.6	6.4	8.9	5.0	7.1
64.0	8.2/60.3	8.0/61.0	8.1/60.9	8.1/61.7	7.5	7.5	6.2	8.1	4.8	6.9
68.0					7.0/66.0	6.7/66.7	6.2/67.8	7.0	4.7	6.5
72.0								6.1	4.6	6.4
76.0								6.0/72.5	4.6/73.9	5.6
80.0										5.2/78.2
84.0										
86.1										
No. of part line	2	1	2	1	2	1	1	1	1	1

Boom length(m)	57.90									
Jib length(m)	12.20		18.30		24.40		30.50		36.55	
Jib offset angle(°)	10	30	10	30	10	30	10	30	10	30
Working radius(m)										
14.1	27.0	13.5/14.3								
16.0	27.0	13.5	13.8/17.6		23.2/16.1	13.5/16.3				
18.0	27.0	13.5	13.7	13.5/18.1	22.7	13.5				
20.0	27.0	13.5	13.4	13.4	22.2	13.5	10.1/21.9	13.5		
22.0	27.0	13.5	13.0	13.0	21.7	13.5	10.1	13.5	11.8/20.1	
24.0	27.0	13.5	12.6	12.6	21.3	13.5	9.7	13.5	7.7/25.7	11.1
26.0	27.0	13.5	12.1	12.1	20.8	13.5	9.4	13.5	7.6	10.9
28.0	25.8	13.5	11.8	11.8	20.4	13.5	9.1	13.5	7.4	10.6
30.0	24.5	13.5	11.5	11.5	19.6	13.5	8.8	13.5	7.1	10.4
32.0	23.2	13.5	11.2	11.2	18.7	13.5	8.6	13.5	7.0	10.1
34.0	22.1	13.5	10.9	10.9	17.7	13.5	8.3	13.5	6.8	10.0
36.0	20.6	13.5	10.6	10.6	17.0	13.5	8.1	13.5	6.5	9.7
38.0	18.9	13.5	10.4	10.4	16.2	13.5	7.9	13.4	6.4	9.5
40.0	17.3	13.5	10.1	10.1	15.5	13.5	7.7	13.1	6.2	9.3
42.0	16.0	13.5	10.0	10.0	14.9	13.5	7.5	12.6	6.0	9.1
44.0	14.7	13.5	9.8	9.8	14.3	13.5	7.4	12.1	5.9	8.8
46.0	13.6	13.5	9.6	9.6	13.8	13.5	7.2	11.6	5.8	8.6
48.0	12.6	12.6	9.4	9.4	13.1	13.1	7.0	11.1	5.6	8.4
50.0	11.6	11.6	9.3	9.3	12.1	12.1	7.0	10.8	5.5	8.1
52.0	10.8	10.8	9.1	9.1	11.2	11.2	6.8	10.4	5.4	8.0
54.0	10.0	10.0	9.0	9.0	10.5	10.5	6.7	10.1	5.3	7.8
56.0	9.3	9.3	8.9	8.9	9.7	9.7	6.6	9.8	5.1	7.6
58.0	8.6	8.6	8.8	8.8	9.1	9.1	6.5	9.5	5.1	7.4
60.0	8.1	8.1	8.2	8.2	8.4	8.4	6.4	9.0	5.0	7.3
64.0	7.3/62.9	7.1/63.6	7.1/63.6	7.0	7.3	7.3	6.3	7.9	4.9	7.0
68.0				6.8/64.4	6.4	6.4	6.2	6.8	4.8	6.7
72.0					6.2/68.7	6.2/69.4	6.1/70.5	6.0	4.6	6.2
76.0								5.4/75.1	4.6	5.4
80.0									4.6/76.6	4.7
84.0										4.5/80.8
88.0										3.5/82.7
91.4										
No. of part line	2	1	2	1	2	1	1	1	1	1

Boom length(m)	60.95									
Jib length(m)	12.20		18.30		24.40		30.50		36.55	
Jib offset angle(°)	10	30	10	30	10	30	10	30	10	30
Working radius(m)										
14.1	27.0/14.6	13.5/14.8								
16.0	27.0	13.5			23.2/16.5	13.5/16.7				
18.0	27.0	13.5	13.8/18.1	13.5/18.5	22.8	13.5				
20.0	27.0	13.5	13.5	13.5	22.3	13.5				
22.0	27.0	13.5	13.1	13.1	21.8	13.5	10.1/22.3	13.5		
24.0	27.0	13.5	12.6	12.6	21.4	13.5	9.8	13.5	11.7/20.6	
26.0	27.0	13.5	12.3	12.3	21.0	13.5	9.5	13.5	7.7/26.1	11.0
28.0	26.5	13.5	12.0	12.0	20.6	13.5	9.2	13.5	7.5	10.7
30.0	25.2	13.5	11.6	11.6	20.1	13.5	8.9	13.5	7.3	10.5
32.0	23.9	13.5	11.3	11.3	19.1	13.5	8.6	13.5	7.0	10.2
34.0	22.3	13.5	11.1	11.1	18.2	13.5	8.5	13.5	6.8	10.0
36.0	20.3	13.5	10.8	10.8	17.4	13.5	8.2	13.5	6.6	9.8
38.0	18.7	13.5	10.6	10.6	16.7	13.5	8.0	13.5	6.5	9.6
40.0	17.1	13.5	10.3	10.3	16.0	13.5	7.8	13.3	6.3	9.3
42.0	15.7	13.5	10.1	10.1	15.3	13.5	7.6	12.8	6.1	9.1
44.0	14.5	13.5	9.9	9.9	14.8	13.5	7.5	12.3	6.0	9.0
46.0	13.3	13.5	9.7	9.7	13.8	13.5	7.3	11.9	5.8	8.8
48.0	12.3	12.3	9.6	9.6	12.8	12.8	7.1	11.5	5.7	8.6
50.0	11.3	11.3	9.4	9.4	11.8	11.8	7.0	11.1	5.5	8.4
52.0	10.5	10.5	9.3	9.3	11.0	11.0	6.9	10.7	5.5	8.1
54.0	9.7	9.7	9.1	9.1	10.1	10.1	6.8	10.3	5.4	8.0
56.0	9.0	9.0	9.0	9.0	9.4	9.4	6.6	10.0	5.3	7.8
58.0	8.3	8.3	8.6	8.6	8.8	8.8	6.5	9.3	5.1	7.6
60.0	7.7	7.7	7.9	7.9	8.1	8.1	6.5	8.7	5.0	7.5
64.0	6.6	6.6	6.8	6.8	7.0	7.0	6.4	7.5	4.9	7.1
68.0	6.3/65.6	6.0/66.3	6.2/66.2	6.0/67.0	6.0	6.0	6.2	6.5	4.8	6.8
72.0					5.3/71.3	5.1	5.5	5.6	4.7	5.9
76.0								5.3/73.1	4.9	4.6
80.0									4.5/77.7	4.4
84.0										3.9/83.5
88.0										
91.4										
No. of part line	2	1	2	1	2	1	1	1	1	1

Notes — Fly jib capacities







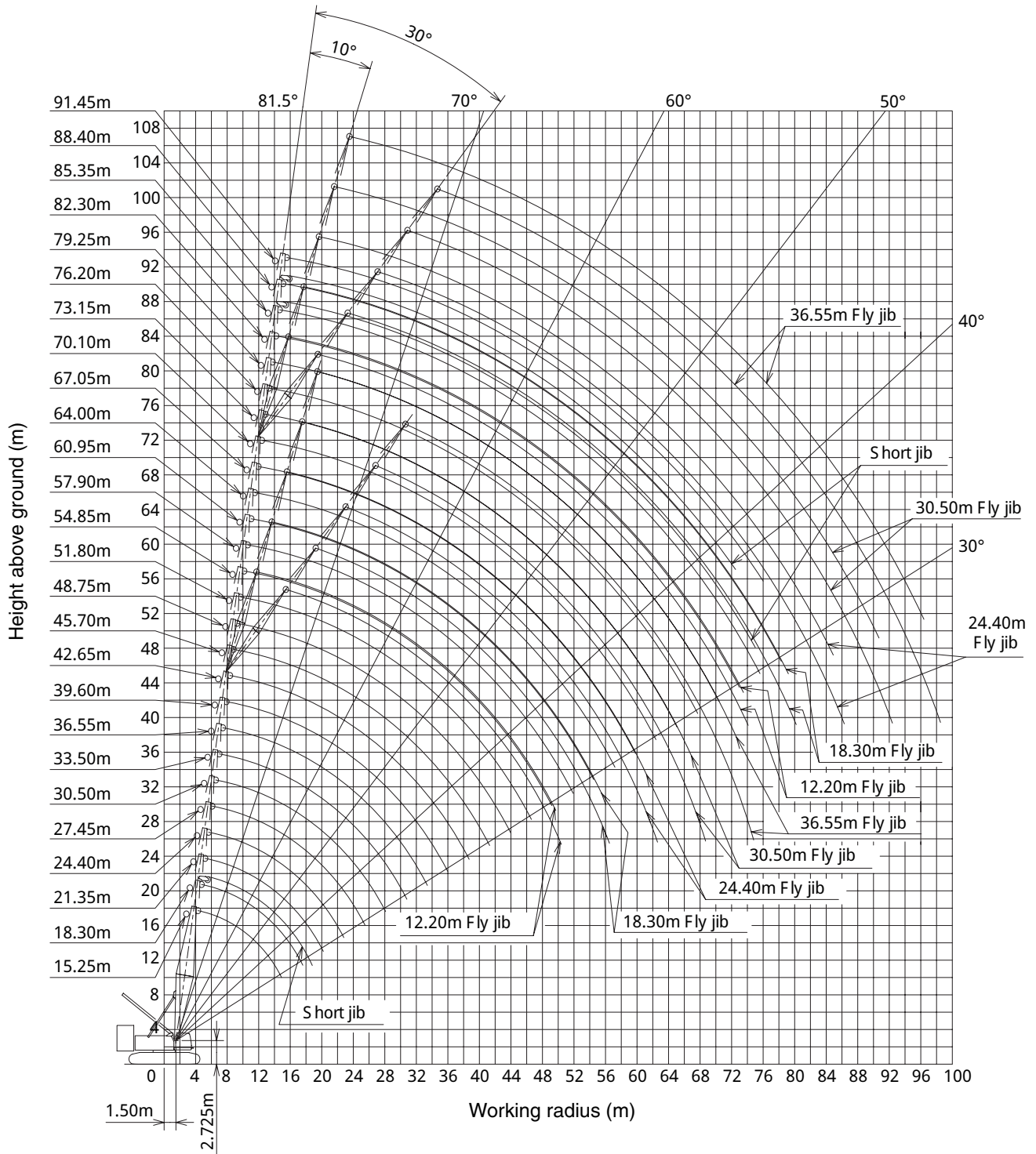
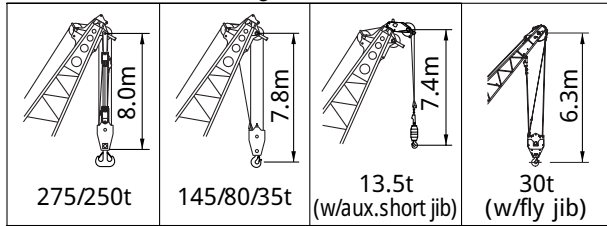



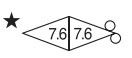
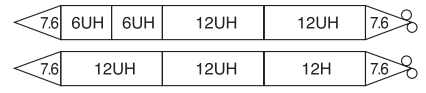
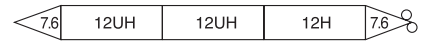

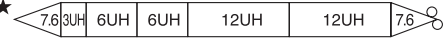
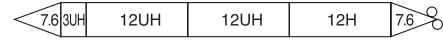
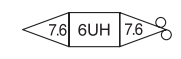
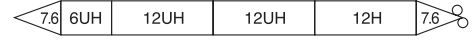
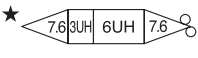
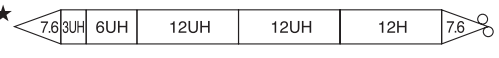
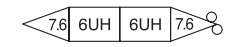
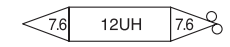
1. Capacities included in these charts are the maximum allowable, and are based on machine standing level on firm supporting surface under ideal job conditions.
2. Capacities are in metric tons, and are rated in accordance with European EN13000 Standards in terms of machine stability and structural strength limitations; the figures surrounded by bold lines are based on factors other than those which would cause a tipping condition.
3. Capacities are based on freely suspended loads and make no allowance for such factors as the effect of wind, sudden stopping of loads, supporting surface conditions, and operating speeds. Operator must reduce load ratings to take such conditions into account. Deduction from rated capacities must be made for weight of hook block, weighted ball/hook, sling, spreader bar, or other suspended gear.
Hook block weight is as follows:
35t.....0.9ton 13.5t0.6ton
4. All capacities are rated for 360° swing.
5. Least stable rated condition is over the side.
6. An 102.8ton counterweight and 18.0ton carbody weight are required for all capacities on these charts.
7. Attachment must be erected and lowered over the ends of the crawler mounting.
8. Maximum fly jib length permitted — 36.55m.
Maximum boom plus fly jib combination length permitted — 70.1m+36.55m.
9. Capacities when handling load off main boom head sheaves in case of mounting fly jib on top of boom are detailed; if required, please consult us or nearest distributor.

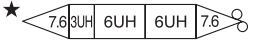
Liftcrane Working Ranges

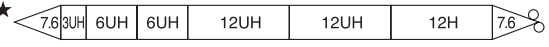
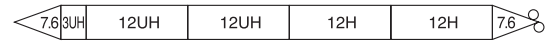
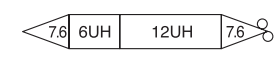
Hook lift allowance height:

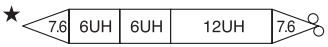
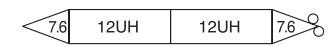
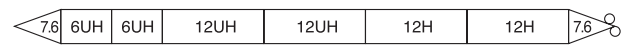
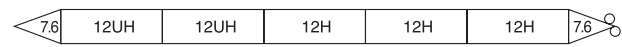
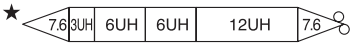
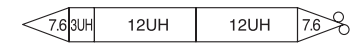

Boom Combination Diagram

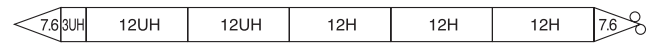
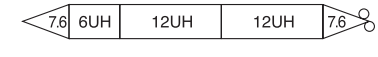
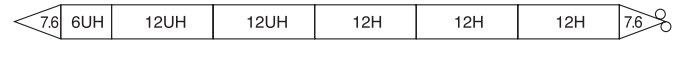
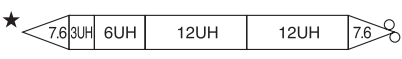
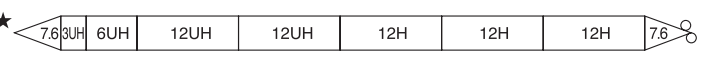
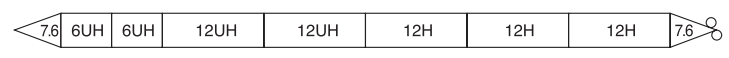
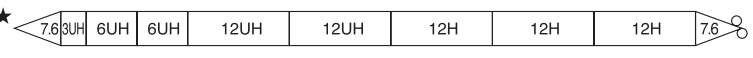
Boom length (m)	Boom combination	Boom length (m)	Boom combination
15.25	★ 	51.80	 
18.30	★ 	54.85	★  
21.35		57.90	
24.40	★ 	60.95	★ 
27.45	 	64.00	 
30.50	★  	67.05	★  
33.50		70.10	
36.55	★ 	73.15	★ 
39.60	★  	76.20	 
42.65	★  	79.25	★  
45.70		82.30	
48.75	★ 	85.35	★ 
		88.40	
		91.45	★ 

Note: 1. The meanings of figures and symbols shown above are as follows:

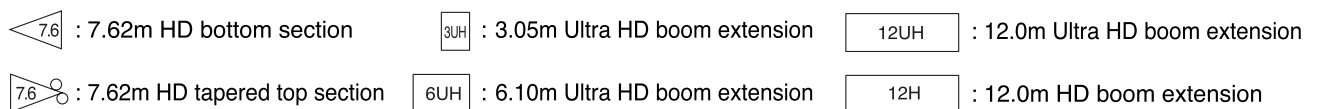

2. A star mark (★) indicates manufacturer's recommended boom configuration in a consideration that it is able to set boom length in the pitch of 3.05 meters from its maximum length; other boom configuration with no star mark (★) is not able to do such an arrangement of boom length.

General Dimensions

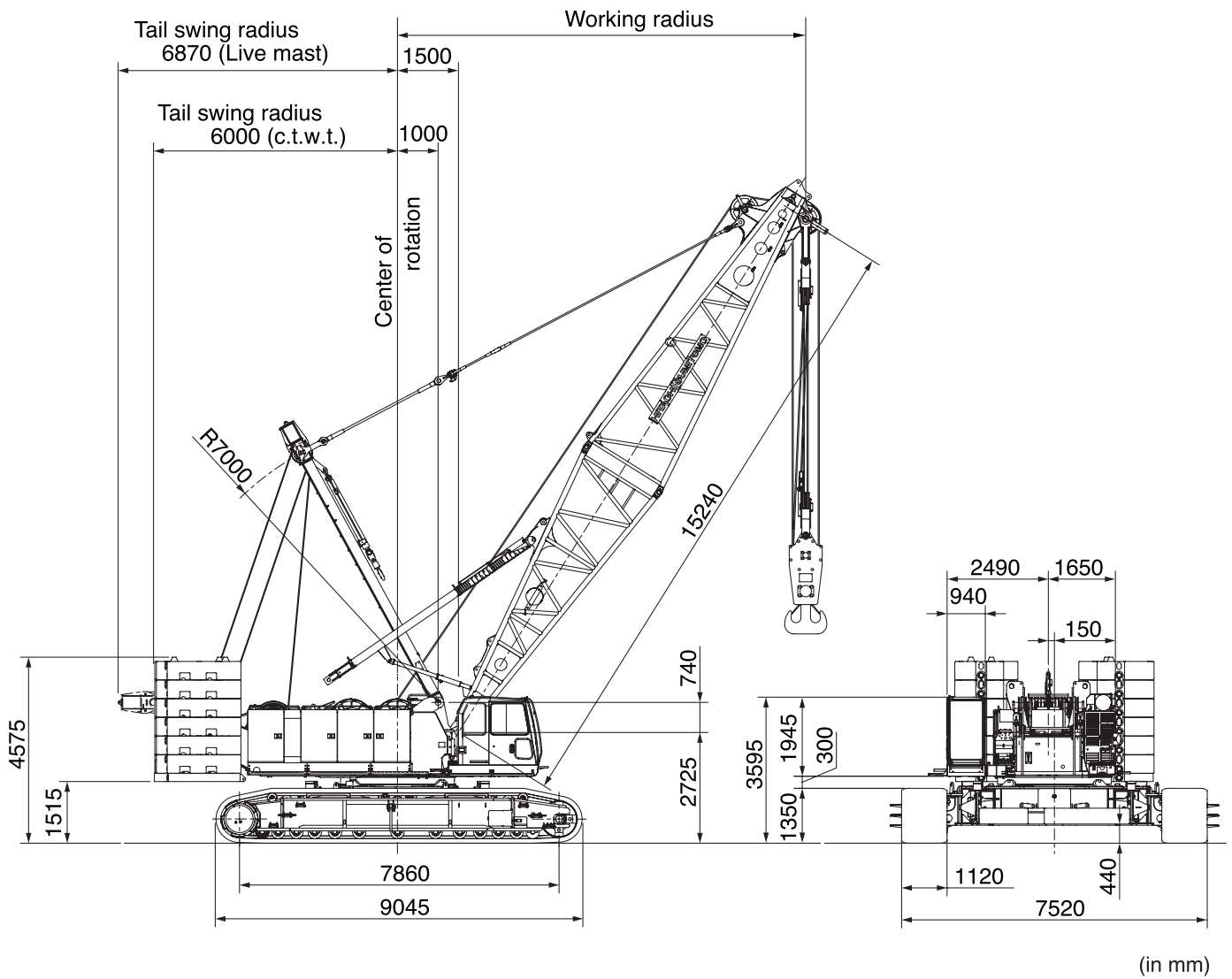

Note: The above general arrangement is under liftcrane application with 15.25m basic boom, and optional 275t hook block.

Transport Data

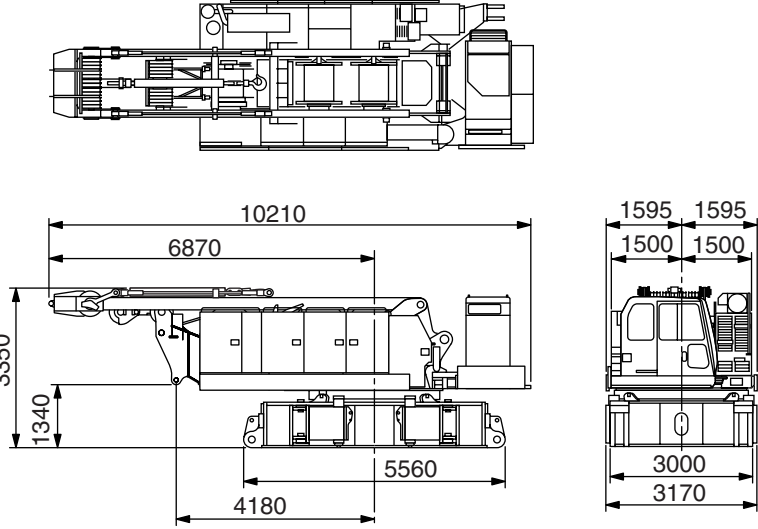
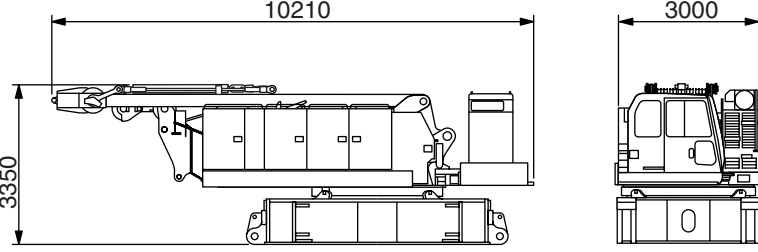
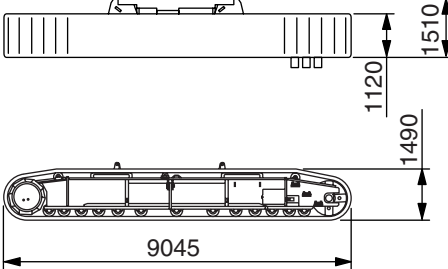
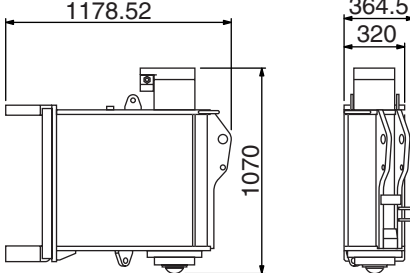
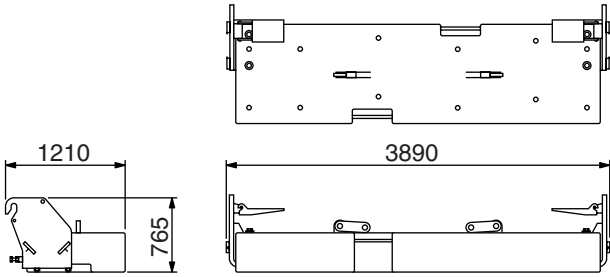
Description	Q'ty	Dimensions(mm)	Mass(kg)
Superstructure with: 1. Carbody frame; 2. Boom live mast w/bridle; 3. Front drum cable; 4. B/H drum cable, and 5. Carbody jack-up device.	1		44,900
Superstructure with: 1. Carbody frame; 2. Boom live mast w/bridle; 3. Front drum cable, and 4. B/H drum cable.	1		42,500
Crawler Side Frame	2		@22,200
Carbody Jack-up Cylinder (w/beam)	4		@600
Carbody Weight	2		@9,000

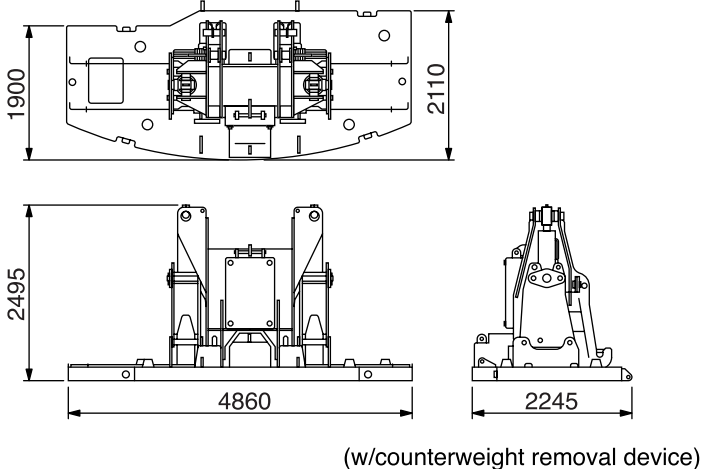
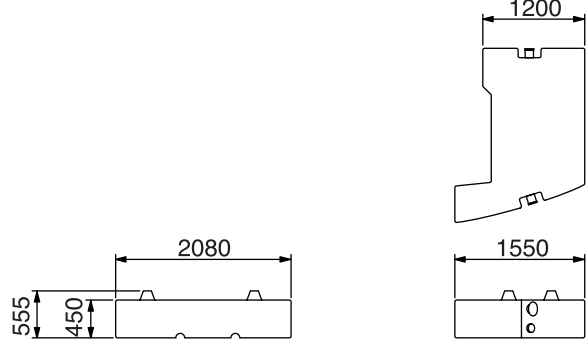
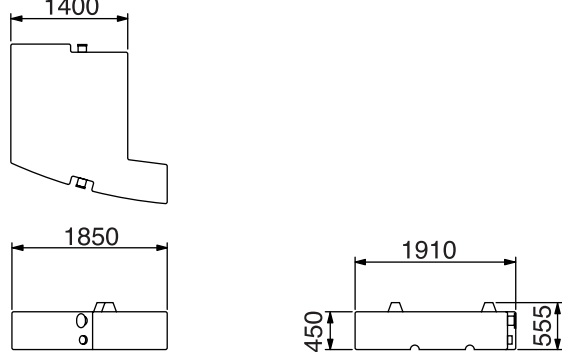
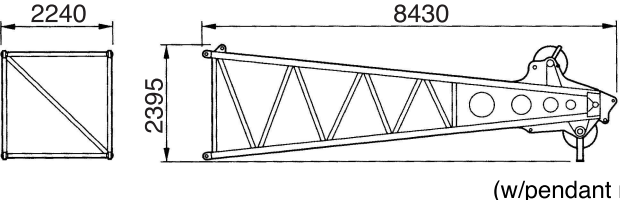
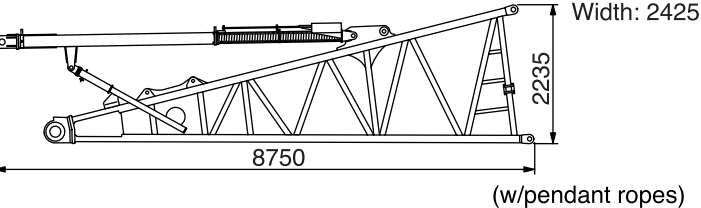
Description	Q'ty	Dimensions(mm)	Mass(kg)
Base Counterweight	1	 <p>(w/counterweight removal device)</p>	22,400
Counterweight "R"	6		@6,900
Counterweight "L"	6		@6,500
7.60m HD Boom Top Section	1	 <p>(w/pendant ropes)</p>	3,300
7.60m HD Boom Bottom Section (w/backstops)	1	 <p>Width: 2425</p> <p>(w/pendant ropes)</p>	4,400

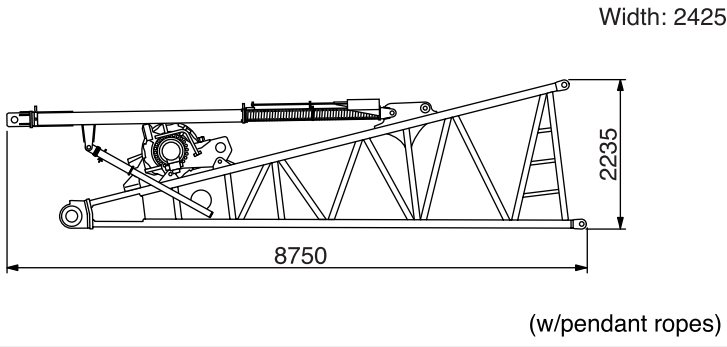
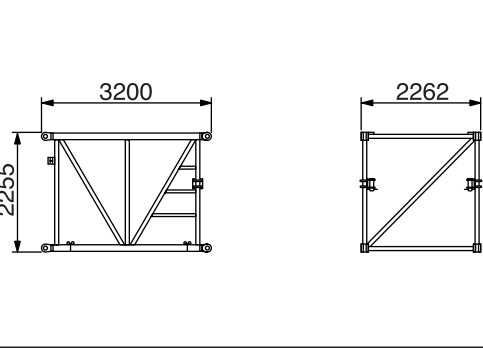
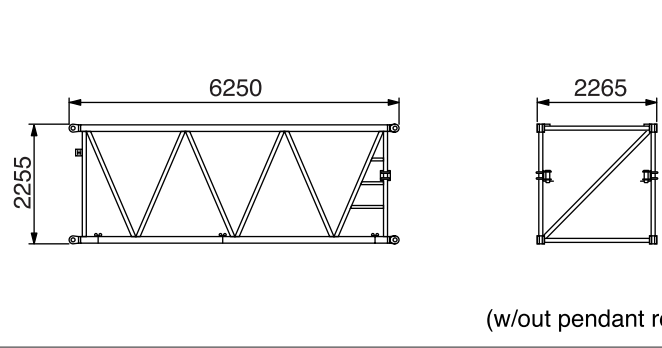
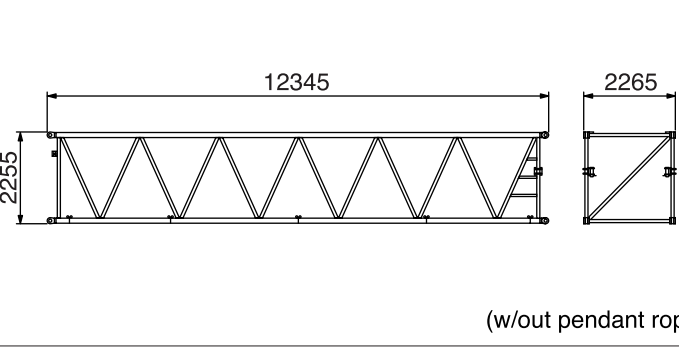
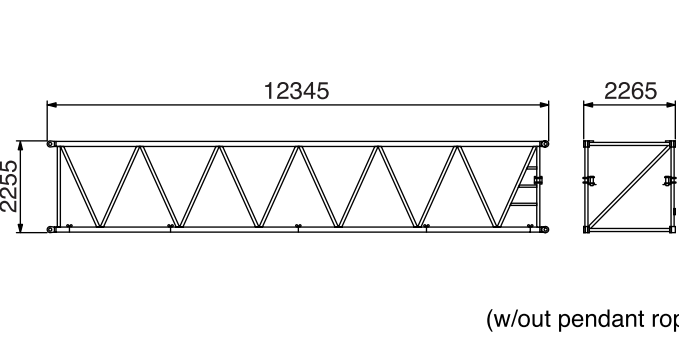
Description	Q'ty	Dimensions(mm)	Mass(kg)
7.60m HD Boom Bottom Section (w/luffing jib hoist drum) (w/backstops)	1	 <p style="text-align: right;">Width: 2425</p> <p style="text-align: center;">8750</p> <p style="text-align: right;">2235</p> <p style="text-align: right;">(w/pendant ropes)</p>	6,900
3.05m Ultra HD Boom Extension	1	 <p style="text-align: center;">3200</p> <p style="text-align: right;">2262</p> <p style="text-align: left;">2255</p> <p style="text-align: right;">(w/out pendant ropes)</p>	800
6.10m Ultra HD Boom Extension	1	 <p style="text-align: center;">6250</p> <p style="text-align: right;">2265</p> <p style="text-align: left;">2255</p> <p style="text-align: right;">(w/out pendant ropes)</p>	1,400
12.20m Ultra HD Boom Extension	1	 <p style="text-align: center;">12345</p> <p style="text-align: right;">2265</p> <p style="text-align: left;">2255</p> <p style="text-align: right;">(w/out pendant ropes)</p>	2,500
12.20m HD Boom Extension	1	 <p style="text-align: center;">12345</p> <p style="text-align: right;">2265</p> <p style="text-align: left;">2255</p> <p style="text-align: right;">(w/out pendant ropes)</p>	2,300

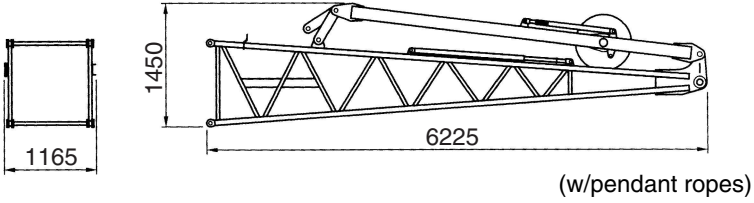
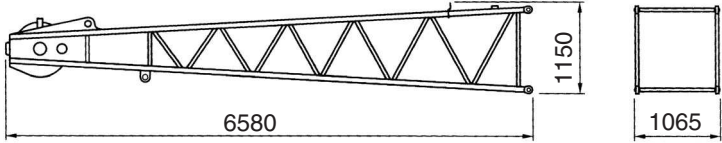
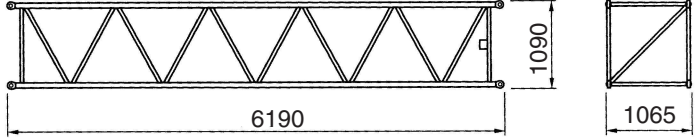
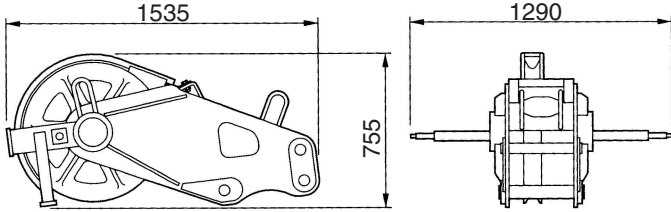
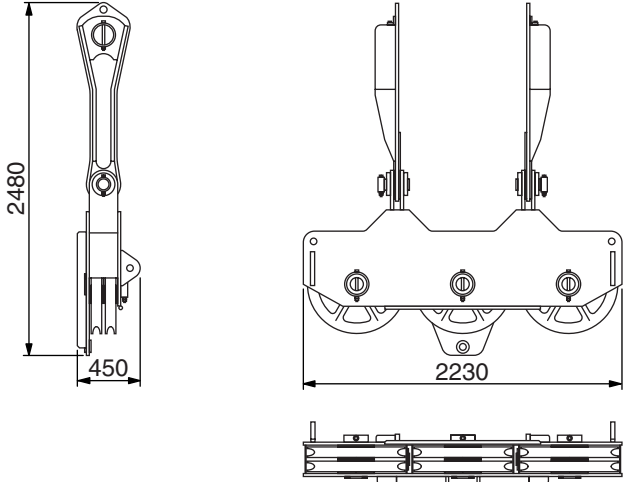
Description	Q'ty	Dimensions(mm)	Mass(kg)
6.10m Fly Jib Bottom Section (w/strut)	1		1,250
6.10m Fly Jib Top Section	1		650
6.10m Fly Jib Extension	1		400
Aux. Short Jib	1		300
Upper 6-hanger Sheave Block	1	 <p data-bbox="581 2084 1333 2142">Note: This is pinned to boom head shaft, and available to lift the load exceeding 145t, and up to 275t.</p>	1,300

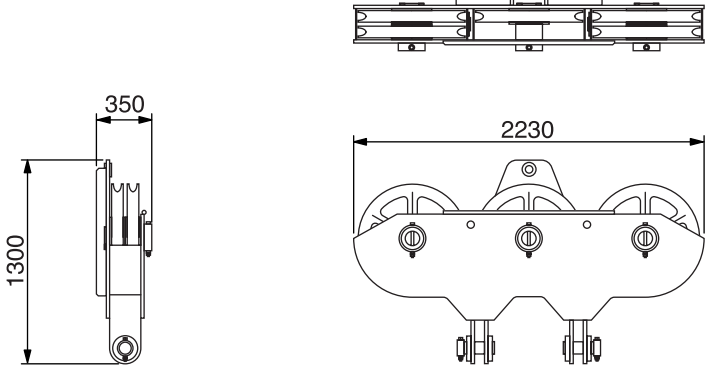
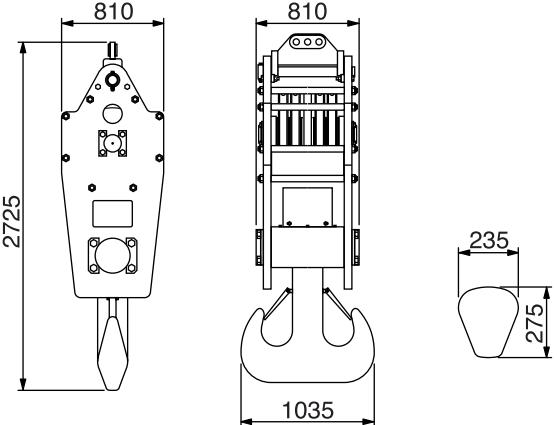
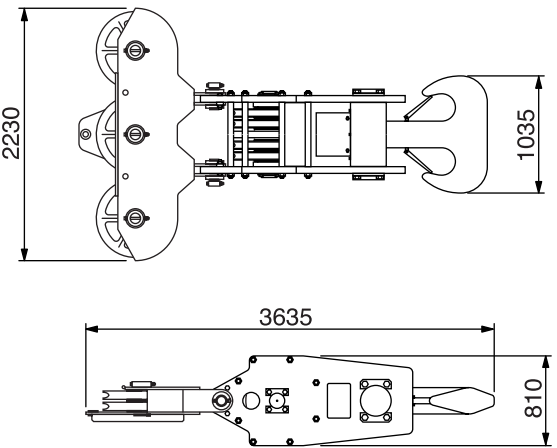
Description	Q'ty	Dimensions(mm)	Mass(kg)
Lower 5 -hanger Sheave Block	1	 <p data-bbox="570 920 1339 973">Note: This is pinned to 145t hook block each of 275t/250t lift use, and available to lift the load exceeding 145t, and up to 275t/250t.</p>	1,000
145t Hook Block	1	 <p data-bbox="581 1529 1325 1556">Note: This is available for 275t lift with a lower 5-hanger sheave block.</p>	3,300
275t Hook Block (w/5-hanger sheave block)	1		4,300

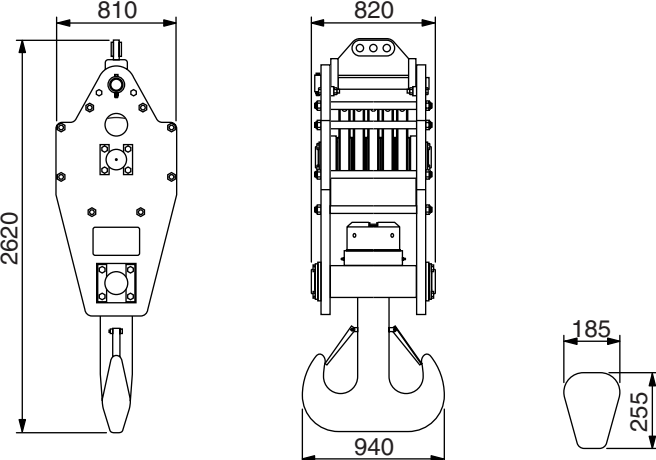
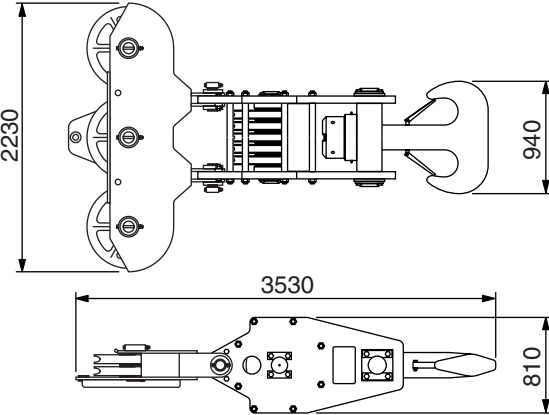
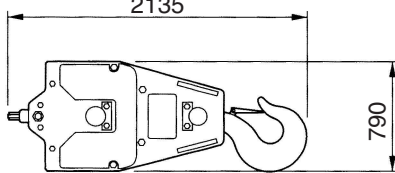
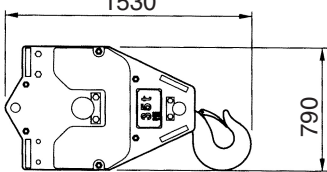
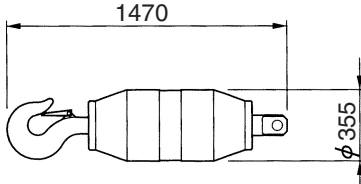
Description	Q'ty	Dimensions(mm)	Mass(kg)
145t Hook Block	1	 <p data-bbox="581 897 1321 925">Note: This is available for 250t lift with a lower 5-hanger sheave block.</p>	2,700
250t Hook Block (w/5-hanger sheave block)	1		3,700
80t Hook Block	1	 <p data-bbox="1214 1572 1328 1600">Width: 520</p>	1,400
35t Hook Block	1	 <p data-bbox="1214 1790 1328 1818">Width: 395</p>	900
13.5t Ball Hook Block	1		600

Note: All of dimensional figures are of with no export packing; in the case that an export packing is done on each cargo, the dimension in height or height/width or height/width/length increases appropriately, and then cubic measurement and mass each comes up accordingly.

Standard and Optional Equipment

	Standard equipment	Optional equipment
Superstructure	<ul style="list-style-type: none"> ● Mitsubishi 6M70-TL diesel engine with a 272kW <370ps> rated output; ● Hydraulic system with three variable displacement axial piston pumps and one fixed displacement duplicate tandem gear pump; provided with an aluminum-make independent oil cooler; ● Control system with one each of quadruplicate and triplicate tandem valves and pilot-operated universal joystick and arm chair single axis control levers; provided with "EPC" controller (easy-precise-minute engine rpm and hyd. pump oil flow control device) electrically linked with engine foot throttle, and specially-tailored pressure compensating valves. In addition, drum rotation speed control is desighed on; ● Front and rear main operating drum winches of 245kN<25t> line pull with 596mm dia. drum lagging driven by independent variable hyd. motor; each provided with multiple wet-disc type automatic brake with no free-fall function; ● Boom hoist mechanism with a twin-drum design driven by a hyd. motor with automatic brakes; provided with drum rotation speed control design; ● Swing mechanism with heavy-duty turntable bearing; driven by two hyd. motors w/spring-applied, power hydraulically released multiple wet-disc brakes; provided with speed control design; ● Bail frame with a 12-sheave machinery and single center sheave; pinned to a rear part of upper revolving frame; ● 940mm wide, full-vision operator's cab with a stamped-and-rounded corner design and large front window; provided with an arrangement of joystick plus armchair operator control station, instrument panel and engine foot throttle. Swing-away and tilting mechanisms, and air-conditioner are provided too; ● An 102.8ton counterweight; provided with a self-removal device for full weight; ● Machinery cab with hinged doors; ● 24-volt electrical system with two 12-volt batteries; ● Lighting system: <ul style="list-style-type: none"> ● Two 70W working lights; ● One 10W interior cab light; ● Accessories; <ul style="list-style-type: none"> ● AM/FM radio w/clock; ● Engine hourmeter; ● Engine tachometer;indicated on display panel of LMI; ● Fuel gauge; ● Eng. water temp. gauge; ● Engine over-heat indicator; available on display panel of LMI; ● Hyd. oil over-temp. indicator; available on display panel of LMI; ● 24V electric outlet; ● Dual, intermittent window shield wipers with washers; available on both front and roof windows; ● Emergency escape hammer; ● Cigar lighter; ● Ash tray; ● Book holder; ● Sunvisor; ● Sunshade; ● Cup Holder; ● Non-skid surfaces; ● Cab front step; ● Cab sidestep; ● Cab floor mat; ● Superstructure under-cover. ● Std. spare parts and tools. 	<ul style="list-style-type: none"> ● Luffing jib hoist drum winch; ● Luffing jib hoist drum cable; ● Hydraulic tagline winder; ● Drum rollers; available on front/rear main drums; ● Fire extinguisher; ● Catwalks, along both sides of machinery cab; ● Re-fuel pump; ● Electric cab fan; ● Anemometer; ● Front and rear main operating winch drums available to operate in two brake modes of automatic and free-fall functions, i/o std.; provided with clutchless, multiple wet-disc brake unit on each drums; ● Portable engine-hydraulic power pack; required when luffing jib att.

	Standard equipment	Optional equipment
Undercarriage	<ul style="list-style-type: none"> ● 6,400mm gauge by 9,045mm long crawler lower with removable crawler side frames; provided with four of tip blocks with pins, lugs and hyd. joint-pin removal cylinders; ● Crawler drive units with shoe-in type traction motor with wet-disc type automatic brakes; ● 1,120mm wide track shoes; ● Manual track tension adjusting devices; ● Carbody jack-up device w/4-vertical hyd. jack-up cylinder and remote control unit; ● 18ton carbody weight; ● Lifetime lubricated track components; ● Crawler side steps. 	<ul style="list-style-type: none"> ● Automatic track tension adjusting device, i/o manual one as std.
Liftcrane Att.	<ul style="list-style-type: none"> ● 15.25m basic crane boom; 7.62m bottom section, and 7.62m tapered top section w/five head sheaves, and two guide sheaves; provided with boom foot pin removal cylinders; ● Boom live mast and bridle frame with a 12-sheave machinery; provided with "quick draw" power hyd. cylinder; ● Main crane hoist cable; 28mm dia./450m long; ● Boom hoist cable; 22.4mm dia./320m long; 	<ul style="list-style-type: none"> ● 3.05m ultra heavy-duty boom extension; ● 6.10m ultra heavy-duty boom extension; ● 12.20m ultra heavy-duty boom extension; ● 12.20m heavy-duty boom extension; ● 12.20m basic fly jib; 6.10m bottom and top sections with jib strut and boom/jib quylene pendants; ● 6.10m fly jib extension; ● Auxiliary short jib; ● 275/145t with a 5-hanger sheave block; ● 250/145t with a 5-hanger sheave block; ● 145t hook block (275t use); ● 145t hook block (250t use); ● 80t hook block; ● 35t hook block; ● 13.5t ball hook; ● Six-hanger sheave block (pinned to boom head shaft); required together with 275t hook block when lifting load exceeds 145ton, and available up to 275ton lift; ● Five-hanger sheave block (pinned to boom head shaft); required together with 250t hook block when lifting load exceeds 145ton, and available up to 250ton lift. ● Aux. crane hoist cable, 28mm dia./350m long; available for fly jib application; ● Aux. crane hoist cable, 28mm/160m long; available for aux. short jib application; ● Mid-point link; required when boom length exceeds 88.40m; ● Boom skywalk; available for all sections of liftcrane main boom.
Lifting jib Att.		<p>—To be advised later —</p>

	Standard equipment	Optional equipment
Safety Devices	<ul style="list-style-type: none"> ● Load Moment Indicator; this is a computerized automatic over-load preventing system incl. total safe operation control system; provided with a graphic display panel indicating ten and some kinds of present lifting conditions; ● Drum rope over-payout preventing device; ● Lifting height meter; ● Main and aux. drum pawl locks; ● Boom hoist drum pawl lock (w/automatic locking device); ● Swing lock; ● Swing alarm; ● Travel alarm; ● Hook over-hoist limiting device; ● Boom over-hoist and -lowering limiting device; ● Dual boom over-hoist limiting device; ● Boom backstops; ● Speed slowdown device; ● Boom angle indicator; ● Level gauge; fitted on floor of operator's cab; ● Swing brake lamp; ● Warning lamps; available for pilot line; ● Swing brake safety circuit; ● Non-drum brake preventing device; ● Signal horn; ● Hook latch; ● Control lever locks; provided on two armchair control levers for travel; ● Fool proof shut-off system; ● Engine monitoring lamps; ● Rear view mirrors; ● Free-fall interlocking device; ● Travel direction arrow; ● Front-end att. erection mode; ● Drum mirror; ● LMI safety circuit-off switch. 	<ul style="list-style-type: none"> ● Aux. hook over-hoist limiting device; ● Three color percentage indicator; ● Microphone & loud-speaker; ● Drum light. <p>Followings are standard in case of luffing jib attachment:</p> <ul style="list-style-type: none"> ● Luffing jib angle detector; ● Luffing jib load detector; ● Luffing jib hook over-hoist limiting device; ● Luffing jib over-hoist and -lowering limiting device; ● Luffing jib hoist drum pawl lock (if luffing jib hoist drum is optionally provided); ● Luffing jib backstops; ● Dual luffing jib over-hoist limiting device; ● Rear post backstops (hyd. cylinder type).

MEMO

A series of horizontal dotted lines for writing.

SCX2800-2

Hitachi Sumitomo Heavy Industries Construction Crane Co., Ltd.

12-14, Ueno 7-chome, Taito-ku, Tokyo 110-0005, Japan

Phone: 81-3-3845-1387 Facsimile: 81-3-3845-1394

- We are constantly improving our products and therefore reserve the right to change designs and specifications without notice.
- Units in this specification are shown under International System of Units; the figures in parenthesis are under Gravitational System of Units as old one.

Address Inquires to:

Printed in Japan
0605(A)T01.EA077
(Superedes 0604(A)T01.EA074)

Courtesy of Crane.Market



SCX2800-2

275-M ton Hydraulic Crawler Crane
Luffing Jib Att.

*EN Rating
Asian / European Issue*

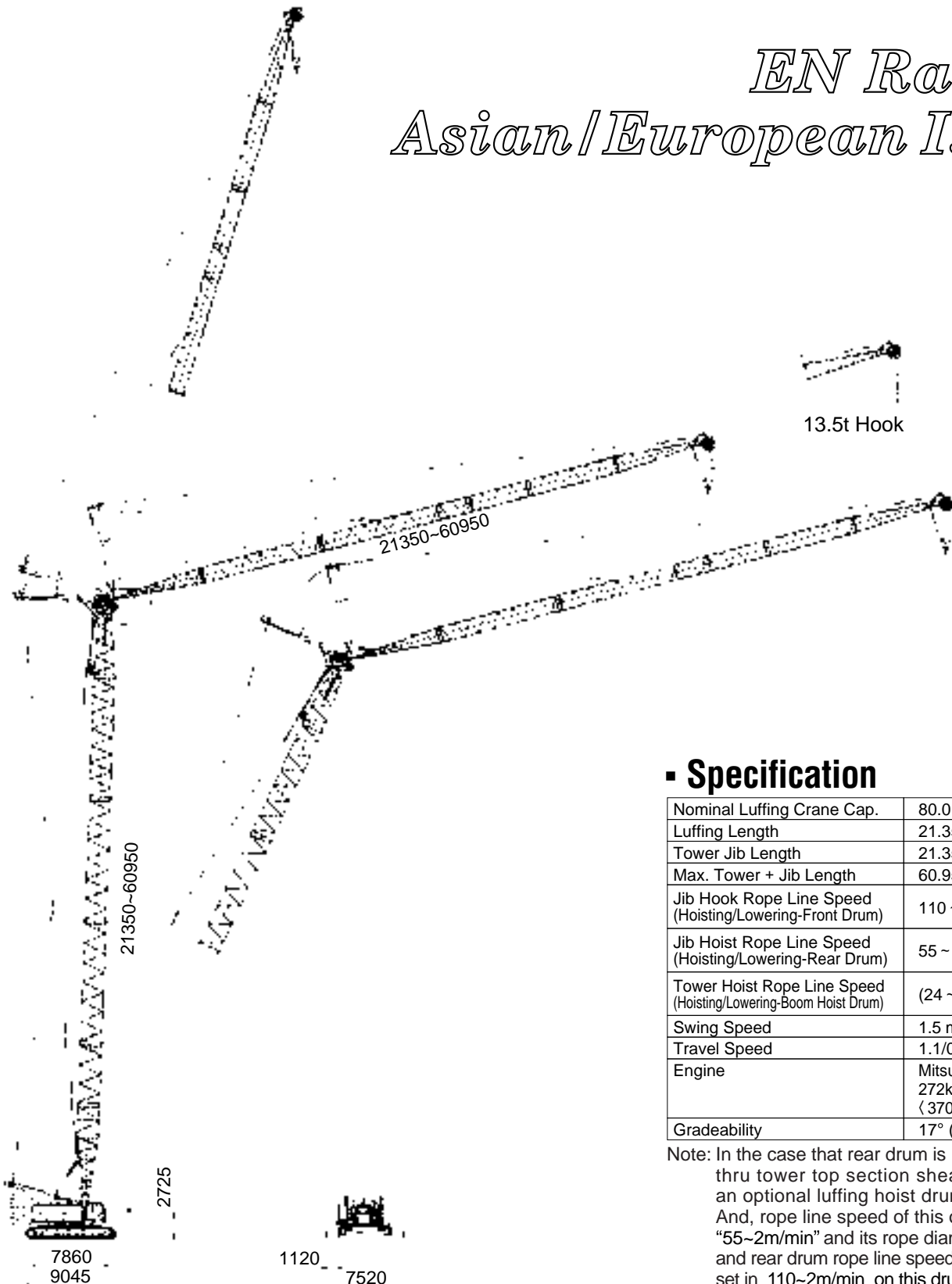

■ Specification

Nominal Luffing Crane Cap.	80.0 t × 9.3 m
Luffing Length	21.35 m ~ 60.95 m
Tower Jib Length	21.35 m ~ 60.95 m
Max. Tower + Jib Length	60.95 m + 60.95 m
Jib Hook Rope Line Speed (Hoisting/Lowering-Front Drum)	110 ~ 2.0 m/min
Jib Hoist Rope Line Speed (Hoisting/Lowering-Rear Drum)	55 ~ 2.0 m/min
Tower Hoist Rope Line Speed (Hoisting/Lowering-Boom Hoist Drum)	(24 ~ 1.0 m/min) × 2
Swing Speed	1.5 min ⁻¹ (1.5 rpm)
Travel Speed	1.1/0.5 km/hr
Engine	Mitsubishi 6M70-TL 272kW/2,000min ⁻¹ (370 ps/2,000rpm)
Gradeability	17° (30%)

Note: In the case that rear drum is used for liftwork thru tower top section sheave machinery, an optional luffing hoist drum is necessary. And, rope line speed of this optional drum is "55~2m/min" and its rope diameter is "28mm", and rear drum rope line speed is automatically set in 110~2m/min on this drum arrangement.

Front-end Attachment

TOWER BOOM:

- Lattice construction, round tubular main chords, alloy, hi-ten steel, with bracing of round steel tubing.
- Tower boom connectionsIn-line pin connections at 2.10m deep by 2.10m wide.
- Basic towerFour-piece, 21.35m basic length; 7.62m heavy-duty bottom section, one 6.10m ultra heavy-duty tower extension, 7.30m heavy-duty top section and 0.32m head section; provided with a 2-guide sheave for luffing jib crane hoist cable and the other cable for liftwork thru tower head top sheave machinery on an upper part of 7.30m tapered extension boom, and two plate links pinned to a part of 7.62m bottom section to adjust a little bit tower boom pendant rope length according to tower length. A 0.32m head section pins luffing jib bottom section, and rear post.
- Tower top sheave machineryThree head sheaves mounted on anti-friction bearings of conventional non-sealed grease type. An 80t lift is available as maximum.
- Ultra heavy-duty tower boom extensionAvailable in 3.05m, 6.10m and 12.20m with tower boom/rear post pendants.
- Heavy-duty tower boom extensionAvailable in 12.20m with tower boom/rear post pendants.
- Tower boom length21.35m to 60.95m; the configuration of a 60.95m tower boom as maximum as recommended is as under: (1) 7.62m heavy-duty tower bottom section, (2) 3.05m ultra heavy-duty boom extension × 1 pc., (3) 6.10m ultra heavy-duty boom extension × 1 pc., (4) 12.20m ultra heavy-duty boom extension × 2 pcs., (5) 12.20m heavy-duty boom extension × 1 pc., (6) 7.30m tower top section, and (7) 0.32m tower head section.
- Tower boom luffing angle88° thru 65° (according to tower boom/luffing jib combination).

Notes:

- All of tower booms except 0.32m tower head section and 7.30m tapered extension can be converted to the general liftcrane boom attachment.
- In converting tower boom attachment of 60.95m as shown above to the general liftcrane boom attachment of 91.45m as maximum, one set of 7.62m tapered crane top section, one set of 6.10m ultra heavy-duty boom extension and two sets of 12.20m heavy-duty boom extensions are additionally required.
- All of ultra heavy- and heavy-duty boom extensions are designed with no intermediate diagonal bracing(s); the diagonal bracing is only designed at one of two picture frames. Accordingly, it is able to nest luffing jib extension into appropriate boom extension in length.

LUFFING JIB:

- Lattice construction, round tubular main chords, alloy hi-ten steel, with bracing of round steel tubing.
- Luffing jib connectionsIn-line pin connections at 1.55m deep by 1.55m wide.
- Basic luffing jibThree-pieces, 21.35m basic length; 9.15m bottom section, one 3.05m jib extension and 9.15m top section.
- Luffing jib top head machineryThree head and one guide sheaves mounted on anti-friction bearings of conventional non-sealed greas type.
- Luffing jib extensionsAvailable in 3.05m, 6.10m and 9.15m lengths with pendants.
- Heavy-duty luffing jib extensionAvailable in 12.20m with pendants.
- Mid-point suspension cableRequired when luffing jib length exceeds 51.80m.
- Maximum luffing jib length60.95m; a 60.95m tower jib configuration is as under: (1) 9.15m bottom section, (2) 12.20m heavy-duty jib extension × 2 pcs., (3) 3.05m jib extension × 1 pc., (4) 6.10m jib extension × 1 pc., (5) 9.15m jib extension × 1 pc., and (6) 9.15m jib top section.
- Luffing jib angleAvailable from 15° thru 73° to ground (according to tower boom/luffing jib combination possible).

FRONT AND REAR POSTS:

All-welded box construction; 8.9m long for front post pinned to 9.15m luffing jib bottom section, and 7.3m long for rear post pinned to 0.32m tower head section. Provided with a nylon sheave of three (3) for front post, and of four (4) for rear post for 7-part rope hoist reeving between posts. Rear post provides two backstops with power hydraulic cylinders to easily set rear post position, and front post equips a luffing jib crane hoist cable guide sheave.

HOOK BLOCKS:

To be selected from 80t, 35t and 13.5t hook blocks (as same as those of the HOOK BLOCKS mentioned in to "Front-end Attachment" of separate SCX2800-2 SPECIFICATIONS).

DRUM DATA:

See DRUM DATA mentioned into page 8 of separate SCX2800-2 SPECIFICATIONS.

HOIST REEVING:

No. of part line	Luffing jib & jib foot crane hoists					
	6	5	4	3	2	1
Max. load (ton)	80.0	67.5	54.0	40.5	27.0	13.5

Note: The actual lifting capacity is, however, restricted by the luffing jib crane capacity and/or by the SWL of appropriate hook capacity.

CABLES:

See CABLES mentioned into page 8 of separate SCX2800-2 SPECIFICATIONS.

WORKING WEIGHT:

Approx. 252ton with 60.95m tower boom, 60.95m tower jib, 102.8ton counterweight, 18.0ton carbody weight, 1,120mm wide track shoes and 80t hook block.

GROUND PRESSURE:

140.3kPa <1.43kg/cm²> under a 252ton working weight mentioned above.

Luffing Jib Crane Capacities - 80 metric tons

■ w/21.35m Tower

Jib Length (m)	21.3				24.4				27.4				30.5				33.5			
Tower Angle (°)	88	83	75	65	88	83	75	65	88	83	75	65	88	83	75	65	88	83	75	65
Working radius(m)																				
9.0	80.0/9.4																			
10.0	79.8				72.3/10.3				63.0/11.2											
12.0	75.6	77.3/13.0			69.1				61.7				67.7/12.1					56.8/13.0		
14.0	71.3	75.2			66.4	67.7/14.2			59.3	59.1/15.3			65.2					55.8		
16.0	59.6	67.2			59.5	65.2			57.5	58.2			59.6	56.6/16.5				52.9	53.5/17.6	
18.0	51.1	58.9	57.5/18.6		51.0	58.8			50.8	56.3			51.0	54.2				50.1	53.5	
20.0	44.6	50.6	53.3		44.5	50.5	53.1/20.1		44.3	50.3	48.2/21.6		44.5	48.3				44.7	48.2	
22.0	39.5	44.2	47.4		39.4	44.1	47.2		39.2	43.9	47.1		39.3	42.7	43.9/23.2			39.5	42.7	
24.0	36.3/23.5	39.2	42.5	38.4/25.1	35.3	39.1	42.4		35.1	38.9	42.2		35.2	38.3	42.1			35.3	38.2	40.5/24.7
26.0		36.5/25.3	38.4	36.8	31.9	35.0	38.3	35.0/27.0	31.7	34.8	38.2		31.7	34.6	38.1			31.9	34.6	38.1
28.0			35.0	33.5	31.3/26.4	31.7	35.0	33.4	28.9	31.5	34.8	31.7/29.0	28.9	31.5	34.7			29.0	31.6	34.7
30.0			34.8/28.2	30.8		31.2/28.3	32.1	30.7	27.2/29.4	28.7	31.9	30.5	26.4	28.6	31.9	29.3/30.9		26.5	28.8	31.8
32.0				28.5/31.7			30.6/31.2	28.3		27.3/31.2	29.5	28.1	24.4	26.2	29.4	28.0	24.4	26.3	29.4	27.1/32.9
34.0								26.3			27.3	26.1	24.1/32.3	23.8	27.3	26.0	22.6	24.2	27.2	25.9
36.0								25.7/34.6			27.2/34.1	24.3		23.6/34.2	25.1	24.2	21.4/35.3	21.8	25.1	24.1
38.0											23.0/37.6			24.1/37.1	22.6			20.7/37.1	23.2	22.5
40.0															21.2				21.5	21.1
42.0																20.8/40.5				19.8
44.0																				19.0/43.5
46.0																				

■ w/21.35m Tower

Jib Length (m)	36.6				39.6				42.7				45.7				48.8			
Tower Angle (°)	88	83	75	65	88	83	75	65	88	83	75	65	88	83	75	65	88	83	75	65
Working radius(m)																				
12.0	48.8/13.9																			
14.0	48.7				41.1/14.8				36.5/15.7											
16.0	47.0				40.4				36.3				30.8/16.6					27.5/17.2		
18.0	45.7	46.3/18.7			39.4	39.0/19.9			35.1				30.1					27.2		
20.0	43.1	44.2			38.3	39.0			34.1	34.0/21.0			29.2					26.4		
22.0	39.4	41.6			37.5	37.9			33.3	33.7			28.5	28.5/22.2				25.7	25.4/23.0	
24.0	35.2	37.7			35.5	37.0			32.7	32.6			27.9	28.0				25.1	25.0	
26.0	31.7	34.5	37.7/26.2		32.0	34.4	35.1/27.7		31.7	31.8			27.4	27.5				24.6	24.4	
28.0	28.8	31.5	34.6		29.0	31.4	34.6		28.8	30.4	30.9/29.3		27.1	27.0				24.1	23.8	
30.0	26.4	28.6	31.7		26.5	28.8	31.7		26.3	27.6	30.7		26.6	26.4	26.0/30.8			23.5	23.4	22.7/31.9
32.0	24.2	26.2	29.2		24.4	26.3	29.3		24.2	25.9	29.1		24.4	25.6	25.7			23.3	22.9	22.6
34.0	22.4	24.1	27.1	24.9/34.9	22.5	24.2	27.1		22.3	24.0	26.9		22.5	23.9	25.2			22.4	22.7	22.4
36.0	20.8	22.3	25.0	24.0	20.9	22.4	25.1	23.3/36.8	20.7	22.2	24.9		20.9	22.4	24.8			20.7	21.6	22.0
38.0	19.4	20.6	23.1	22.4	19.4	20.8	23.2	22.3	19.2	20.5	23.0	21.5/38.8	19.4	20.7	23.2			19.3	20.1	21.6
40.0	19.2/38.2	18.6	21.4	21.0	18.2	19.3	21.5	20.9	17.9	19.1	21.2	20.7	18.1	19.3	21.5	20.3/40.7		18.0	18.7	21.4
42.0			19.9	19.7	17.5/41.1	17.6	20.0	19.6	16.8	17.8	19.7	19.4	16.9	18.0	19.9	19.4		16.8	17.4	20.5
44.0			19.9/43.0	18.6		16.9/43.0	18.6	18.5	15.8	16.6	18.4	18.3	15.8	16.8	18.5	18.3		15.7	16.3	19.1
46.0				17.5			17.5/45.9	17.5	15.7/44.1	15.1/45.9	17.2	17.2	14.9	15.8	17.3	17.2		14.8	15.3	17.8
48.0				17.4/46.4				16.5			16.1	16.3	14.4/47.0	14.5	16.2	16.3		13.9	14.4	16.6
50.0								15.9/49.4			15.8/48.8	15.4		13.6/48.9	15.2	15.4		13.3/49.3	13.5	15.6
52.0												14.7			14.4/51.8	14.6		12.9/51.1	14.7	14.5
54.0												14.5/52.3				13.9			13.8	13.8
56.0																13.5/55.2				13.1
58.0																				12.6/57.5

■ w/21.35m Tower

Jib Length (m)	51.8				54.9				57.9				61.0				
Tower Angle (°)	88	83	75	65	88	83	75	65	88	83	75	65	88	83	75	65	
Working radius(m)																	
18.0	262/18.1				23.1/19.0				20.2/19.9								
20.0	25.4				22.7				20.1				17.7/20.8				
22.0	24.6				22.0				19.5				17.4				
24.0	24.0	24.0/24.2			21.3	21.0/25.3			18.9				16.8				
26.0	23.1	23.4			20.7	20.8			18.3	18.3/26.5			16.3	16.0/27.6			
28.0	22.6	22.5			20.0	20.2			17.8	17.9			15.8	15.9			
30.0	22.2	22.0			19.6	19.5			17.1	17.4			15.3	15.4			
32.0	21.9	21.6	21.3/33.5		19.3	19.1			16.1	16.7			14.4	15.0			
34.0	21.6	21.3	21.2		19.0	18.8	18.6/35.0		15.3	15.8			13.6	14.2			
36.0	20.5	21.1	20.7		18.8	18.5	18.4		14.5	14.9	16.1/36.5		12.9	13.5			
38.0	19.1	19.9	20.3		18.6	18.3	17.9		13.8	14.2	16.0		12.2	12.8	13.8		
40.0	17.7	18.5	20.0		17.7	18.1	17.6		13.1	13.5	15.2		11.6	12.2	13.2		
42.0	16.6	17.2	19.6		16.5	17.1	17.3		12.6	12.9	14.4		11.1	11.6	12.5		
44.0	15.5	16.1	18.2	17.6/44.2	15.4	16.0	17.1		12.0	12.3	13.7		10.6	11.0	11.9		
46.0	14.6	15.1	17.0	16.9	14.5	15.0	16.9	16.5/46.1	11.6	11.8	13.1		10.1	10.6	11.3		
48.0	13.7	14.2	15.9	15.9	13.6	14.1	15.8	15.9	11.2	11.4	12.5	13.1/48.1	9.7	10.1	10.8		
50.0	12.9	13.3	14.9	15.1	12.8	13.3	14.8	15.0	10.8	11.0	12.0	12.6	9.4	9.7	10.3	11.1/50.1	
52.0	12.2	12.6	14.0	14.3	12.1	12.5	13.9	14.2	10.5	10.6	11.5	12.1	9.1	9.4	9.9	10.7	
54.0	12.1/52.2	11.7	13.2	13.6	11.4	11.8	13.1	13.5	10.2	10.4	11.1	11.6	8.8	9.1	9.5	10.2	
56.0		11.7/54.1	12.4	12.9	10.9/55.2	11.2	12.4	12.8	10.0	10.1	10.8	11.2	8.6	8.7	9.2	9.8	
58.0			12.1/57.0	12.3		10.8/57.0	11.7	12.2	9.9	10.0	10.4	10.8	8.4	8.5	8.9	9.4	
60.0				11.7			11.1/59.9	11.6	9.8/58.1	9.6	10.2	10.5	8.3	8.3	8.7	9.1	
62.0				11.5/60.4				11.1			10.0	10.3	8.2/61.0	8.2	8.5	8.8	
64.0								10.7/63.4				9.7/62.9	10.0		8.2/62.9	8.3	8.6
66.0												9.9			8.3/65.8	8.4	
68.0												9.9/66.3				8.3	
70.0																8.3/69.3	

■ w/24.40m Tower

Jib Length (m)	21.3				24.4				27.4				30.5				33.5			
Tower Angle (°)	88	83	75	65	88	83	75	65	88	83	75	65	88	83	75	65	88	83	75	65
Working radius(m)																				
9.0	79.6/9.5																			
10.0	79.5				71.6/10.4				62.4/11.3											
12.0	75.8	76.7/13.4			68.7				61.3				66.9/12.2				56.2/13.1			
14.0	72.7	75.4			66.0	67.1/14.6			58.9	58.4/15.7			64.5				55.0			
16.0	61.7	67.1			62.3	65.1			57.1	58.1			60.3	56.5/16.8			53.0			
18.0	52.7	59.7	54.4/19.4		53.3	59.7			53.1	56.1			53.3	53.8			50.2	53.3		
20.0	45.9	53.7	52.8		46.5	53.7	49.8/20.9		46.3	53.4			46.5	49.3			46.7	48.0		
22.0	40.5	47.0	46.8		41.1	46.9	46.7		41.0	46.7	45.5/22.4		41.1	44.1			41.3	43.5		
24.0	36.9/23.6	41.6	42.0		36.8	41.4	41.9		36.7	41.3	41.7		36.7	39.1	41.7		36.9	39.3	38.5/25.5	
26.0		37.8/25.7	38.0	35.4/26.4	33.2	37.1	37.9		33.1	36.9	37.7		33.2	35.1	37.7		33.3	35.3	37.7	
28.0			34.7	32.9	32.4/26.5	33.5	34.6	32.4/28.3	30.2	33.3	34.4		30.2	31.8	34.3		30.3	31.9	34.3	
30.0			33.1/29.0	30.2		32.6/28.6	31.7	30.1	28.3/29.5	30.3	31.6	29.4/30.3	27.6	29.0	31.5		27.7	29.1	31.5	
32.0				27.9			29.3	27.7		28.7/31.6	29.1	27.5	25.3	26.6	29.1	27.3/32.2	25.3	26.7	29.0	
34.0				26.7/33.0				25.7			27.0	25.5	24.8/32.4	24.6	26.9	25.4	23.4	24.6	26.9	25.1/34.2
36.0								23.9/35.9			26.1/34.9	23.7		24.1/34.5	25.1	23.6	22.2/35.4	22.8	25.0	23.6
38.0												22.2			23.5/37.9	22.1		21.3/37.5	23.4	22.0
40.0												21.4/38.9				20.7			21.9	20.6
42.0																19.5/41.8			21.4/40.8	19.4
44.0																				18.3
46.0																				17.8/44.8

■ w/24.40m Tower

Jib Length (m)	36.6				39.6				42.7				45.7				48.8			
Tower Angle (°)	88	83	75	65	88	83	75	65	88	83	75	65	88	83	75	65	88	83	75	65
Working radius(m)																				
14.0	48.2				40.8/14.9				36.0/15.8											
16.0	46.6				40.2				35.9				30.5/16.7				27.3/17.4			
18.0	44.7	45.8/19.1			39.3				34.7				29.8				27.0			
20.0	42.9	44.5			38.2	38.6/20.3			33.7	33.8/21.4			29.0				26.2			
22.0	40.0	40.8			37.0	37.7			32.9	33.5			28.2	28.4/22.5			25.5	25.1/23.4		
24.0	36.8	38.6			35.4	36.7			32.3	32.7			27.6	28.1			24.8	24.9		
26.0	33.1	35.1	35.9/27.0		33.4	34.3			31.5	31.5			27.2	27.4			24.3	24.3		
28.0	30.1	31.8	34.2		30.3	32.0	33.5/28.5		29.9	30.6			26.8	26.8			23.9	23.7		
30.0	27.5	28.9	31.4		27.7	29.1	31.4		27.3	28.9	30.5/30.1		26.6	26.4	25.8/31.6		23.3	23.2		
32.0	25.3	26.6	28.9		25.5	26.7	29.0		25.2	26.5	28.7		25.4	25.9	25.7		23.1	22.7	22.5/32.7	
34.0	23.3	24.5	26.8		23.5	24.6	26.8		23.3	24.4	26.6		23.4	24.6	25.1		23.0	22.5	22.2	
36.0	21.6	22.6	24.9	23.3/36.2	21.8	22.9	24.9		21.6	22.7	24.7		21.7	22.8	24.7		21.6	22.4	21.7	
38.0	20.1	21.1	23.3	21.9	20.2	21.4	23.3	21.8/38.1	20.0	21.3	23.1		20.3	21.2	23.1		20.0	21.0	21.4	
40.0	19.8/38.3	19.6	21.8	20.5	18.9	19.7	21.8	20.5	18.6	19.7	21.6	20.1/40.1	18.9	19.8	21.6		18.7	19.5	21.1	
42.0		19.3/40.4	20.5	19.2	18.1/41.2	18.4	20.5	19.2	17.5	18.3	20.3	19.0	17.6	18.6	20.3	19.0	17.5	18.2	20.2	17.8/43.5
44.0			19.5/43.7	18.1		17.2/43.4	19.3	18.1	16.4	17.1	19.1	17.9	16.5	17.4	19.1	17.8	16.4	17.0	19.0	17.7
46.0				17.1			18.2	17.1	16.2/44.2	15.8	18.0	16.8	15.5	16.3	18.0	16.8	15.4	16.0	17.9	16.7
48.0				16.3/47.7			17.9/46.7	16.1		15.7/46.3	17.0	15.9	15.0/47.1	15.2	17.0	15.9	14.5	15.0	16.9	15.8
50.0							15.3			16.3/49.6	15.1		14.5/49.3	16.1	15.0	13.9/49.4	14.2	16.0	14.9	
52.0								15.0/50.6				14.3			15.3	14.2		13.4/51.5	15.2	14.1
54.0												13.7/53.6			15.1/52.6	13.5			14.4	13.4
56.0																12.8			14.1/54.8	12.7
58.0																12.7/56.5				12.1
60.0																				11.9/58.8

■ w/24.40m Tower

Jib Length (m)	51.8				54.9				57.9				61.0			
Tower Angle (°)	88	83	75	65	88	83	75	65	88	83	75	65	88	83	75	65
Working radius(m)																
18.0	26.0/18.2				22.9/19.1											
20.0	25.3				22.6				20.0				17.6/20.9			
22.0	24.5				21.8				19.4				17.2			
24.0	23.8	23.8/24.5			21.2	20.9/25.7			18.8				16.7			
26.0	22.9	23.3			20.6	20.8			18.2	18.2/26.8			16.2			
28.0	22.4	22.4			19.9	20.2			17.7	17.9			15.7	15.9		
30.0	22.0	21.9			19.5	19.4			17.1	17.4			15.1	15.4		
32.0	21.7	21.5			19.1	19.0			16.2	16.7			14.5	14.9		
34.0	21.5	21.1	21.2/34.2		18.8	18.6	18.4/35.8		15.3	15.8			13.7	14.2		
36.0	21.3	20.9	20.7		18.6	18.3	18.3		14.5	15.0	15.9/37.3		12.9	13.5		
38.0	19.8	20.8	20.3		18.5	18.1	18.0		13.8	14.2	15.8		12.2	12.9	13.8/38.8	
40.0	18.5	19.3	19.9		18.4	18.0	17.6		13.2	13.6	15.1		11.6	12.3	13.4	
42.0	17.3	18.0	19.7		17.2	17.9	17.3		12.6	12.9	14.3		11.1	11.7	12.7	
44.0	16.2	16.8	18.8	16.5/45.5	16.1	16.8	17.0		12.0	12.4	13.6		10.6	11.1	12.1	
46.0	15.2	15.8	17.7	16.5	15.1	15.7	16.9	15.6/47.4	11.6	11.9	13.0		10.1	10.6	11.5	
48.0	14.3	14.8	16.7	15.5	14.2	14.8	16.5	15.5	11.2	11.4	12.4	13.1/49.4	9.7	10.2	11.0	
50.0	13.5	14.0	15.8	14.7	13.4	13.9	15.7	14.6	10.8	11.0	11.9	13.0	9.4	9.8	10.5	11.1/51.3
52.0	12.7	13.2	15.0	13.9	12.6	13.1	14.9	13.8	10.5	10.7	11.5	12.4	9.1	9.4	10.0	11.0
54.0	12.5/52.3	12.4	14.1	13.2	11.9	12.4	14.1	13.1	10.2	10.4	11.1	11.9	8.8	9.0	9.6	10.5
56.0		12.3/54.4	13.3	12.5	11.5/55.3	11.7	13.3	12.5	10.0	10.1	10.7	11.5	8.6	8.7	9.3	10.0
58.0			12.7/57.8	11.9		11.1/57.4	12.5	11.8	9.9	10.0	10.4	11.1	8.4	8.5	9.0	9.6
60.0				11.4			11.9	11.3	9.9/58.2	9.8	10.3	10.7	8.3	8.3	8.7	9.3
62.0				10.8/61.7			11.7/60.7	10.7		9.8/60.3	10.2	10.4	8.2/61.2	8.2	8.5	9.0
64.0								10.3			10.1/63.7	10.1		8.2/63.3	8.3	8.7
66.0								10.1/64.7				9.6			8.3	8.5
68.0												9.2/67.6			8.2/66.6	8.4
70.0																8.3
72.0																8.2/70.6

■w/27.45m Tower

Jib Length (m)	21.3				24.4				27.4				30.5				33.5			
Tower Angle (°)	88	83	75	65	88	83	75	65	88	83	75	65	88	83	75	65	88	83	75	65
Working radius(m)																				
9.0	79.5/9.7																			
10.0	79.4				71.0/10.5				61.8/11.4											
12.0	75.4	75.9/13.8			68.3				60.8				66.1/12.3				55.0/13.2			
14.0	72.2	75.5			65.5	66.7/14.9			58.4				64.0				55.0			
16.0	62.3	67.1			63.0	65.0			56.6	57.8/16.1			60.1	55.7/17.2			53.1			
18.0	53.1	59.7			53.7	59.3			54.3	55.9			54.8	53.7			50.3	52.4/18.3		
20.0	46.2	53.7	50.9/20.2		46.8	53.3	46.7/21.7		47.2	52.4			47.7	49.5			47.7	47.9		
22.0	40.8	48.5	46.3		41.4	48.4	45.9		41.8	47.5	42.8/23.2		42.2	45.3			42.5	43.9		
24.0	36.9/23.7	43.5	41.6		37.0	43.3	41.4		37.4	43.0	41.2		37.8	40.5	39.6/24.7		38.0	40.3		
26.0		38.3	37.6	32.9/27.6	33.4	38.7	37.5		33.8	38.5	37.3		34.1	36.3	37.3		34.2	36.4	36.6/26.3	
28.0		38.0/26.1	34.3	32.3	32.4/26.6	34.9	34.2	30.0/29.6	30.8	34.7	34.0		31.0	32.8	33.9		31.1	32.9	33.9	
30.0			31.8/29.8	29.6		33.3/29.0	31.4	29.4	28.7/29.6	31.6	31.2	27.3/31.6	28.1	29.9	31.1		28.3	30.0	31.1	
32.0				27.3			28.9	27.2		28.9	28.8	26.9	25.8	27.4	28.7	25.4/33.5	25.9	27.5	28.7	
34.0				25.3			28.1/32.8	25.2			26.7	25.0	25.2/32.5	25.3	26.6	24.9	23.9	25.3	26.6	23.5/35.5
36.0				25.1/34.3				23.4			25.1/36.7	23.2		24.3/34.9	24.8	23.1	22.6/35.5	23.4	24.7	23.1
38.0								22.5/37.2				21.7			23.1	21.6		21.6/37.8	23.1	21.5
40.0												20.3			22.7/38.6	20.2			21.6	20.2
42.0													20.2/40.2				19.0		20.6/41.6	18.9
44.0																18.4/43.1				17.8
46.0																				16.8

■w/27.45m Tower

Jib Length (m)	36.6				39.6				42.7				45.7				48.8			
Tower Angle (°)	88	83	75	65	88	83	75	65	88	83	75	65	88	83	75	65	88	83	75	65
Working radius(m)																				
14.0	47.7/14.1				40.3/15.0				35.6/15.9											
16.0	46.7				40.2				35.6				30.1/16.8				27.0/17.5			
18.0	44.8	45.2/19.5			39.1				34.4				29.6				26.8			
20.0	42.9	44.8			38.1	38.3/20.6			33.4	33.6/21.8			28.7				25.9			
22.0	40.1	40.6			37.0	37.4			32.6	33.5			28.0	28.2/22.9			25.2	24.8/23.8		
24.0	37.2	37.9			35.4	36.5			32.0	32.5			27.5	27.9			24.6	24.8		
26.0	34.1	36.1	34.0/27.8		33.8	34.2			31.0	31.2			27.0	27.2			24.1	24.1		
28.0	31.0	32.8	33.8		31.2	32.2	32.0/29.3		29.8	30.2			26.5	26.6			23.7	23.5		
30.0	28.3	29.8	31.0		28.5	30.0	31.0		28.0	29.0	29.8/30.8		26.3	26.2			23.0	23.1		
32.0	25.8	27.3	28.6		26.2	27.5	28.6		25.7	27.3	28.4		25.6	25.7	25.5/32.4		22.8	22.7	22.2/33.5	
34.0	23.8	25.2	26.4		24.2	25.3	26.5		23.7	25.1	26.3		24.0	24.9	25.1		22.8	22.3	22.1	
36.0	22.1	23.3	24.6	21.9/37.4	22.2	23.4	24.6		22.0	23.2	24.4		22.2	23.5	24.1		22.1	22.2	21.7	
38.0	20.6	21.7	23.0	21.4	20.7	21.7	23.0	20.5/39.4	20.4	21.5	22.8		20.8	21.7	22.8		20.5	21.6	21.3	
40.0	20.3/38.4	20.1	21.5	20.0	19.3	20.3	21.5	20.0	19.1	20.0	21.3	18.9/41.4	19.2	20.2	21.3		19.1	20.1	21.0	
42.0		19.5/40.8	20.2	18.8	18.4/41.4	18.9	20.2	18.8	17.9	18.7	20.0	18.5	18.0	18.9	20.0		17.9	18.8	19.9	
44.0			19.1	17.7		17.6/43.7	19.0	17.7	16.8	17.5	18.8	17.4	16.9	17.7	18.8	17.4	16.8	17.6	18.7	16.7/44.8
46.0			18.8/44.5	16.7			18.0	16.7	16.6/44.3	16.3	17.8	16.4	15.9	16.6	17.8	16.4	15.8	16.5	17.6	16.3
48.0				15.8			17.3/47.5	15.7		16.0/46.7	16.8	15.5	15.3/47.2	15.6	16.8	15.5	14.8	15.5	16.7	15.4
50.0				15.4/49.0				14.9			15.9	14.7		14.6/49.6	15.9	14.7	14.2/49.5	14.6	15.8	14.5
52.0								14.2/51.9			15.8/50.4	13.9			15.1	13.9		13.7/51.9	15.0	13.8
54.0												13.2			14.6/53.4	13.2			14.2	13.1
56.0												12.9/54.9					12.5		13.6/55.6	12.4
58.0																12.0/57.8				11.8
60.0																				11.2
62.0																				11.2/60.1

■ w/27.45m Tower

Jib Length (m)	51.8				54.9				57.9				61.0				
Tower Angle (°)	88	83	75	65	88	83	75	65	88	83	75	65	88	83	75	65	
Working radius(m)																	
18.0	25.8/18.4				22.7/19.2												
20.0	25.1				22.4				19.9/20.1				17.4/21.0				
22.0	24.3				21.7				19.3				17.1				
24.0	23.6	23.2/24.9			21.0				18.6				16.6				
26.0	22.8	23.2			20.5	20.7/26.1			18.1	18.0/27.2			16.1				
28.0	22.2	22.2			19.7	20.1			17.6	17.8			15.6	15.7/28.3			
30.0	21.8	21.7			19.3	19.3			17.0	17.3			15.1	15.3			
32.0	21.5	21.3			19.0	18.9			16.2	16.6			14.5	14.9			
34.0	21.3	21.0	21.0/35.0		18.7	18.5			15.3	15.9			13.7	14.3			
36.0	21.1	20.8	20.8		18.5	18.2	18.3/36.6		14.5	15.1			12.9	13.5			
38.0	20.3	20.6	20.3		18.3	18.0	18.0		13.8	14.3	15.8/38.1		12.3	12.9	13.7/39.6		
40.0	18.9	19.9	19.9		18.3	17.9	17.6		13.2	13.6	15.4		11.7	12.3	13.6		
42.0	17.7	18.6	19.6		17.6	17.7	17.2		12.6	13.0	14.6		11.1	11.7	13.0		
44.0	16.6	17.3	18.5		16.5	17.3	17.0		12.1	12.4	13.9		10.6	11.2	12.3		
46.0	15.6	16.3	17.4	15.5/46.8	15.5	16.2	16.8		11.6	11.9	13.2		10.2	10.7	11.7		
48.0	14.6	15.3	16.5	15.1	14.6	15.2	16.3	14.6/48.7	11.2	11.5	12.6		9.7	10.2	11.1		
50.0	13.8	14.4	15.6	14.3	13.7	14.3	15.5	14.2	10.8	11.0	12.1	13.1/50.7	9.4	9.8	10.6		
52.0	13.0	13.6	14.8	13.6	13.0	13.5	14.7	13.5	10.5	10.7	11.6	12.8	9.1	9.4	10.2	11.0/52.6	
54.0	12.8/52.4	12.7	14.0	12.8	12.3	12.7	13.9	12.8	10.2	10.4	11.2	12.2	8.8	9.0	9.8	10.8	
56.0		12.4/54.8	13.3	12.2	11.8/55.4	12.1	13.3	12.1	10.0	10.1	10.8	11.7	8.5	8.7	9.4	10.3	
58.0			12.7	11.6		11.4/57.8	12.6	11.5	9.9	10.0	10.5	11.3	8.4	8.5	9.1	9.9	
60.0			12.5/58.6	11.0			12.0	11.0	9.8/58.3	9.8	10.2	10.8	8.3	8.3	8.8	9.5	
62.0				10.5			11.6/61.5	10.4		9.7/60.7	10.0	10.2	8.2/61.3	8.2	8.6	9.2	
64.0				10.3/63.0				10.0				9.9	9.8		8.1/63.6	8.4	8.9
66.0								9.5				9.9/64.4	9.3			8.3	8.6
68.0													8.9			8.2/67.4	8.4
70.0													8.7/68.9				8.3
72.0																	8.0/71.8

■ w/30.50m Tower

Jib Length (m)	21.3				24.4				27.4				30.5				33.5			
Tower Angle (°)	88	83	75	65	88	83	75	65	88	83	75	65	88	83	75	65	88	83	75	65
Working radius(m)																				
9.0	79.4/9.8																			
10.0	79.3				70.1/10.7				61.1/11.5											
12.0	75.2				67.8				60.4				65.2/12.4				54.1/13.3			
14.0	72.1	74.8/14.2			65.1	65.9/15.3			57.9				62.5				54.1			
16.0	62.9	66.4			63.1	64.9			56.2	57.4/16.4			59.1	53.4/17.6			52.5			
18.0	53.5	59.0			54.2	58.0			54.7	55.7			55.2	52.4			49.7	50.2/18.7		
20.0	46.5	53.1	47.5/21.0		47.1	52.2			47.6	51.3			48.0	47.8			47.1	47.6		
22.0	41.0	48.3	45.4		41.6	47.4	43.6/22.5		42.0	46.6			42.4	43.8			42.8	43.1		
24.0	36.9/23.8	43.3	41.0		37.2	43.2	40.8		37.6	42.7	40.1		38.0	41.2	37.3/25.5		38.3	39.7		
26.0		39.2	37.2		33.6	39.2	37.0		34.0	39.0	36.7		34.3	36.9	36.5		34.5	37.1	34.5/27.1	
28.0		38.3/26.4	33.9	30.4/28.9	32.4/26.7	35.6	33.7		31.0	35.4	33.5		31.2	33.3	33.5		31.3	33.5	33.4	
30.0			31.1	28.9		33.3/29.4	31.0	27.6/30.9	28.7/29.7	32.1	30.8		28.2	30.3	30.7		28.4	30.4	30.7	
32.0			30.3/30.6	26.7			28.6	26.5		29.4	28.4	25.4/32.9	26.0	27.7	28.3		26.1	27.8	28.3	
34.0				24.7			27.0/33.5	24.6		29.1/32.3	26.3	24.3	25.3/32.6	25.6	26.2	23.6/34.8	24.1	25.6	26.2	
36.0				23.2/35.6				22.9			24.5	22.6		23.6/35.3	24.4	22.5	22.7/35.6	23.7	24.4	21.9/36.8
38.0								21.4			24.1/36.5	21.1			22.8	21.0		21.7	22.8	21.0
40.0								21.0/38.5				19.8			21.8/39.4	19.7		21.5/38.2	21.3	19.7
42.0												18.9/41.4				18.5			20.0	18.4
44.0																	17.4		19.8/42.4	17.4
46.0																	17.2/44.4			16.4
48.0																				15.7/47.3

■ w/30.50m Tower

Jib Length (m)	36.6				39.6				42.7				45.7				48.8			
Tower Angle (°)	88	83	75	65	88	83	75	65	88	83	75	65	88	83	75	65	88	83	75	65
Working radius(m)																				
14.0	47.2/142				40.2/15.1															
16.0	46.4				40.0				35.2				29.8/16.9				26.7/17.6			
18.0	44.5	44.6/19.9			38.7				34.3				29.3				26.5			
20.0	42.6	44.4			37.7	37.8/21.0			33.4				28.6				25.7			
22.0	40.2	40.6			36.9	37.2			32.5	33.3/22.1			28.0	28.0/23.3			25.0			
24.0	37.1	37.7			35.4	36.2			31.5	32.3			27.5	27.8			24.4	24.6/24.1		
26.0	34.2	35.1			33.8	34.0			30.3	30.9			27.0	27.0			23.9	24.0		
28.0	31.2	33.3	32.1/28.6		31.5	32.0			29.1	29.4			26.4	26.4			23.5	23.4		
30.0	28.5	30.3	30.5		28.7	30.1	30.3/30.1		28.1	28.3	28.3/31.6		25.8	26.0			22.8	22.9		
32.0	25.9	27.7	28.2		26.4	27.9	28.2		25.9	27.3	27.8		25.0	25.5	25.2/33.2		22.6	22.5		
34.0	24.0	25.5	26.1		24.4	25.7	26.1		23.9	25.5	25.9		24.2	24.4	25.0		22.5	22.0	22.0/34.3	
36.0	22.2	23.6	24.3		22.3	23.7	24.3		22.1	23.5	24.1		22.4	23.7	24.1		21.9	21.9	21.6	
38.0	20.7	21.9	22.7	20.4/38.7	20.8	22.0	22.6		20.6	21.8	22.4		20.8	22.0	22.5		20.7	21.4	21.2	
40.0	20.3/38.5	20.4	21.2	19.5	19.4	20.5	21.2	19.0/40.7	19.2	20.3	21.0		19.4	20.5	21.0		19.3	20.4	20.9	
42.0		19.2/41.2	19.9	18.3	18.5/41.5	19.2	19.9	18.3	18.0	18.9	19.7	17.6/42.7	18.1	19.1	19.7		18.0	19.0	19.6	
44.0			18.8	17.2		17.6	18.7	17.2	16.9	17.7	18.5	17.0	17.0	17.9	18.6	16.7/44.6	16.9	17.8	18.4	
46.0			18.1/45.3	16.2		17.5/44.1	17.7	16.2	16.6/44.4	16.7	17.5	16.0	16.0	16.8	17.5	16.0	15.9	16.7	17.4	15.6/46.1
48.0				15.4			16.7	15.3		16.1/47.1	16.5	15.1	15.3/47.3	15.8	16.5	15.1	14.9	15.7	16.4	14.9
50.0				14.6			16.6/48.3	14.5			15.7	14.3		14.6	15.6	14.2	14.2/49.6	14.7	15.5	14.1
52.0				14.4/50.3				13.7			15.2/51.2	13.5			14.8	13.5		13.7	14.7	13.4
54.0								13.3/53.2				12.8			14.1	12.8		13.6/52.2	14.0	12.7
56.0												12.2			14.0/54.2	12.2			13.3	12.0
58.0												12.1/56.2				11.6			13.1/56.4	11.4
60.0																11.2/59.1				10.9
62.0																				10.5/61.4

■ w/30.50m Tower

Jib Length (m)	51.8				54.9				57.9				61.0			
Tower Angle (°)	88	83	75	65	88	83	75	65	88	83	75	65	88	83	75	65
Working radius(m)																
18.0	25.6/18.5				22.5/19.4											
20.0	24.9				22.3				19.7/20.2				17.3/21.1			
22.0	24.1				21.5				19.1				17.0			
24.0	23.5	23.0/25.3			20.9				18.5				16.5			
26.0	22.6	23.0			20.3	20.5/26.4			18.0	17.9/27.6			15.9			
28.0	22.1	22.1			19.6	20.1			17.5	17.8			15.5	15.6/28.7		
30.0	21.7	21.6			19.1	19.2			16.9	17.2			15.0	15.3		
32.0	21.3	21.2			18.8	18.7			16.2	16.5			14.5	14.8		
34.0	21.1	20.8	20.8/35.8		18.5	18.4			15.3	16.0			13.7	14.2		
36.0	20.9	20.6	20.7		18.3	18.1	18.1/37.4		14.5	15.2			13.0	13.5		
38.0	20.5	20.4	20.3		18.2	17.9	18.0		13.8	14.4	15.7/38.9		12.3	12.8		
40.0	19.1	20.2	19.9		18.1	17.7	17.6		13.2	13.7	15.4		11.7	12.2	13.5/40.4	
42.0	17.8	18.8	19.1		17.7	17.6	17.2		12.6	13.1	14.9		11.1	11.7	13.2	
44.0	16.7	17.6	18.2		16.6	17.5	16.9		12.1	12.5	14.1		10.6	11.2	12.6	
46.0	15.7	16.5	17.2		15.6	16.4	16.7		11.6	12.0	13.4		10.2	10.7	11.9	
48.0	14.7	15.5	16.2	14.5	14.7	15.4	16.1		11.2	11.5	12.8		9.7	10.3	11.3	
50.0	13.9	14.5	15.3	13.9	13.8	14.5	15.3	13.7	10.8	11.1	12.3		9.4	9.8	10.8	
52.0	13.1	13.7	14.5	13.1	13.0	13.6	14.5	13.1	10.5	10.7	11.8	12.7	9.1	9.4	10.3	11.0/53.9
54.0	12.9/52.5	13.0	13.8	12.5	12.3	12.9	13.7	12.4	10.2	10.4	11.3	12.2	8.8	9.0	9.9	10.9
56.0		11.8/55.2	13.1	11.8	11.8/55.5	12.2	13.0	11.7	10.0	10.1	10.9	11.5	8.5	8.7	9.5	10.6
58.0			12.5	11.2		11.4	12.4	11.1	9.9	10.0	10.6	10.9	8.4	8.5	9.2	10.1
60.0			12.1/59.3	10.7		11.4/58.1	11.8	10.6	9.8/58.4	9.9	10.3	10.4	8.2	8.3	8.9	9.7
62.0				10.2			11.2	10.1		9.8/61.1	10.1	9.9	8.1/61.4	8.2	8.6	9.4
64.0				9.7			11.2/62.3	9.6			9.9	9.4		8.1	8.4	9.0
66.0				9.6/64.3				9.2			9.9/65.2	9.0			8.4	8.8
68.0								8.9/67.2				8.6			8.2	8.4
70.0												8.2			8.2/68.2	8.0
72.0												8.1/70.2				7.7
74.0																7.4/73.1

■ w/33.50m Tower

Jib Length (m)	21.3				24.4				27.4				30.5				33.5			
Tower Angle (°)	88	83	75	65	88	83	75	65	88	83	75	65	88	83	75	65	88	83	75	65
Working radius(m)																				
9.0	79.3/9.9																			
10.0	79.1				69.4/10.8				60.3/11.7											
12.0	74.8				67.3				59.9				63.5/12.5				53.2/13.4			
14.0	71.7	71.7/14.5			64.6	65.0/15.7			57.5				61.2				53.2			
16.0	63.4	64.9			62.6	63.8			55.7	56.8/16.8			58.3	50.6/17.9			51.9			
18.0	53.9	57.8			54.6	56.8			54.4	55.4			54.5	50.4			49.2	47.4/19.1		
20.0	46.9	52.0	44.5/21.8		47.4	51.1			47.9	50.2			48.4	47.6			46.5	47.4		
22.0	41.3	47.3	44.1		41.9	46.5	40.9/23.3		42.3	45.7			42.7	43.9			43.0	43.1		
24.0	36.9/23.9	43.1	40.4		37.4	42.6	39.7		37.8	41.8	37.8/24.8		38.2	40.6			38.5	39.8		
26.0		39.0	36.7		33.7	38.9	36.5		34.2	38.6	35.9		34.5	37.9	35.1/26.3		34.8	37.0	32.6/27.9	
28.0		37.6/26.8	33.4		32.4/26.8	35.5	33.3		31.1	35.4	33.1		31.5	34.2	32.9		31.5	34.3	32.5	
30.0			30.7	28.1/30.2		32.9/29.8	30.5		28.7/29.8	32.4	30.3		28.7	31.0	30.3		28.8	31.2	30.2	
32.0			28.9/31.4	26.0			28.2	25.6/32.2		29.9	28.0		26.4	28.4	27.9		26.5	28.5	27.9	
34.0				24.2			26.1	23.9		29.2/32.7	25.9	23.6/34.1	25.5/32.7	26.2	25.9		24.5	26.2	25.8	
36.0				22.5			25.8/34.3	22.3			24.1	22.0		24.2/35.6	24.1	21.9/36.1	22.9/35.7	24.3	24.0	
38.0				21.7/36.8				20.8			23.0/37.3	20.6			22.5	20.5		22.3	22.4	20.3/38.1
40.0								19.6/39.8				19.3			21.1	19.2		21.8/38.6	21.0	19.1
42.0												18.1			20.9/40.2	18.0			19.7	17.9
44.0												17.7/42.7				16.9			19.0/43.2	16.9
46.0																16.0/45.7				15.9
48.0																				15.1
50.0																				14.8/48.6

■ w/33.50m Tower

Jib Length (m)	36.6				39.6				42.7				45.7				48.8			
Tower Angle (°)	88	83	75	65	88	83	75	65	88	83	75	65	88	83	75	65	88	83	75	65
Working radius(m)																				
14.0	46.7/14.3				40.2/15.2															
16.0	45.9				39.6				34.9/16.1				29.4/17.0				26.4/17.7			
18.0	44.3				38.3				34.3				29.3				26.3			
20.0	42.3	43.3/20.2			37.3	37.3/21.4			33.3				28.6				25.5			
22.0	40.2	40.6			36.5	37.0			32.5	32.9/22.5			27.9	27.7/23.7			24.8			
24.0	37.2	37.8			35.5	36.0			31.5	32.1			27.3	27.6			24.2	24.3/24.5		
26.0	34.3	35.5			33.8	33.9			30.4	30.9			26.8	26.9			23.6	23.8		
28.0	31.7	33.4	30.4/29.4		32.0	32.0			29.2	29.6			26.4	26.2			23.2	23.2		
30.0	28.8	31.1	29.8		29.2	30.1	28.6/30.9		27.8	28.4			25.5	25.7			22.7	22.7		
32.0	26.4	28.4	27.8		26.9	28.2	27.6		26.3	27.2	26.8/32.4		24.5	25.4	24.9/33.9		22.3	22.3		
34.0	24.4	26.1	25.7		24.5	26.3	25.7		24.3	25.7	25.4		23.7	24.3	24.9		22.0	21.8	21.8/35.1	
36.0	22.6	24.1	23.9		22.7	24.3	23.9		22.5	24.1	23.7		22.8	23.4	23.7		21.4	21.4	21.6	
38.0	21.1	22.4	22.3		21.2	22.5	22.3		20.9	22.3	22.1		21.2	22.5	22.1		20.9	20.8	21.1	
40.0	20.6/38.6	20.9	20.9	19.0	19.8	21.0	20.9		19.5	20.7	20.7		19.7	21.0	20.7		19.6	20.4	20.6	
42.0		19.7/41.5	19.6	17.8	18.7/41.6	19.6	19.6	17.8	18.3	19.4	19.4	16.5/43.9	18.5	19.6	19.4		18.3	19.4	19.3	
44.0			18.5	16.7		18.3	18.5	16.7	17.2	18.1	18.3	16.5	17.3	18.3	18.3	15.5/45.9	17.2	18.2	18.2	
46.0			17.4	15.8		18.0/44.5	17.4	15.7	16.9/44.5	17.0	17.2	15.5	16.3	17.2	17.2	15.5	16.1	17.0	17.1	14.6/47.4
48.0			17.4/46.1	14.9			16.5	14.9		16.0/47.4	16.3	14.6	15.5/47.5	16.1	16.3	14.6	15.2	16.0	16.2	14.5
50.0				14.1			16.0/49.1	14.1			15.4	13.8		15.1	15.4	13.8	14.4/49.7	15.1	15.3	13.7
52.0				13.6/51.6				13.3			14.6	13.1		14.9/50.4	14.6	13.1		14.1	14.5	13.0
54.0								12.7				12.4			13.8	12.4		13.8/52.6	13.7	12.3
56.0								12.5/54.5				11.8			13.5/54.9	11.8			13.1	11.7
58.0												11.4/57.5					11.2		12.7/57.2	11.1
60.0																	10.7			10.5
62.0																	10.5/60.4			10.0
64.0																				9.9/62.6

■ w/33.50m Tower

Jib Length (m)	51.8				54.9				57.9				61.0			
Tower Angle (°)	88	83	75	65	88	83	75	65	88	83	75	65	88	83	75	65
Working radius(m)																
18.0	25.0/18.6				22.3/19.5											
20.0	24.7				22.1				19.5/20.3				17.2/21.2			
22.0	24.0				21.4				19.0				16.9			
24.0	23.3	22.9/25.7			20.7				18.4				16.3			
26.0	22.5	22.9			20.2	20.3/26.8			17.8	17.7/27.9			15.8			
28.0	21.9	22.0			19.5	20.0			17.4	17.6			15.4	15.4/29.1		
30.0	21.5	21.4			19.0	19.2			16.7	17.2			15.0	15.2		
32.0	21.1	21.0			18.6	18.6			16.3	16.6			14.4	14.8		
34.0	20.9	20.7			18.4	18.3			15.4	16.0			13.7	14.1		
36.0	20.7	20.4	20.6/36.6		18.1	18.0			14.6	15.3			13.0	13.6		
38.0	20.5	20.2	20.3		18.0	17.7	17.9/38.1		13.8	14.5	15.5/39.7		12.3	12.9		
40.0	19.4	20.0	19.8		17.9	17.6	17.6		13.2	13.8	15.5		11.7	12.2	13.4/41.2	
42.0	18.1	19.2	19.1		17.9	17.5	17.2		12.6	13.1	15.1		11.1	11.7	13.3	
44.0	17.0	18.0	18.0		16.9	17.4	16.9		12.1	12.5	14.4		10.6	11.2	12.8	
46.0	15.9	16.8	16.9		15.9	16.8	16.6		11.6	12.0	13.7		10.2	10.7	12.1	
48.0	15.0	15.8	16.0	13.5/49.3	14.9	15.7	15.9		11.2	11.5	13.0		9.7	10.3	11.5	
50.0	14.1	14.9	15.1	13.5	14.1	14.8	15.0	12.8/51.3	10.8	11.1	12.5		9.4	9.8	11.0	
52.0	13.4	14.0	14.3	12.7	13.3	14.0	14.2	12.6	10.5	10.7	11.9	11.9/53.2	9.1	9.4	10.5	
54.0	13.1/52.6	13.3	13.5	12.1	12.6	13.2	13.5	12.0	10.2	10.4	11.5	11.8	8.8	9.0	10.1	11.0/55.2
56.0		12.5/55.6	12.9	11.4	12.0/55.6	12.5	12.8	11.3	10.0	10.2	11.1	11.1	8.5	8.7	9.7	10.9
58.0			12.2	10.9		11.7	12.2	10.8	9.8	10.0	10.7	10.6	8.3	8.5	9.3	10.4
60.0			11.7	10.3		11.5/58.5	11.6	10.2	9.8/58.5	9.8	10.4	10.0	8.2	8.3	9.0	9.9
62.0			11.6/60.1	9.8			11.0	9.7		9.7/61.4	10.1	9.5	8.1/61.5	8.2	8.7	9.4
64.0				9.4			10.7/63.1	9.3			9.9	9.1		8.1	8.5	8.9
66.0				9.0/65.6				8.8			9.8	8.6		8.1/64.4	8.3	8.5
68.0								8.4				8.2			8.2	8.1
70.0								8.3/68.5				7.9			8.2/69.0	7.7
72.0												7.6/71.5				7.4
74.0																7.0
76.0																7.0/74.4

■ w/36.55m Tower

Jib Length (m)	21.3				24.4				27.4				30.5				33.5			
Tower Angle (°)	88	83	75	65	88	83	75	65	88	83	75	65	88	83	75	65	88	83	75	65
Working radius(m)																				
10.0	78.6				68.6/10.9				59.6/11.8											
12.0	74.3				66.8				59.3				59.9/12.6				51.3/13.5			
14.0	71.2	67.9/14.9			64.0				56.9				58.8				51.3			
16.0	64.0	63.4			62.1	62.3			55.2	56.0/17.2			56.8				50.4			
18.0	54.4	56.5			55.0	55.5			53.9	54.6			53.7	50.4/18.3			48.6	47.2/19.5		
20.0	47.2	50.9			47.8	50.1			48.2	49.2			48.7	47.4			46.1	47.2		
22.0	41.6	46.3	41.9/22.5		42.1	45.5			42.6	44.7			43.0	43.1			43.3	43.3		
24.0	37.0	42.5	39.2		37.6	41.7	38.4/24.1		38.1	41.0	35.4/25.6		38.4	39.6			38.7	40.0		
26.0		38.8	36.1		33.9	38.6	35.5		34.4	37.8	34.9		34.7	36.9	33.1/27.1		34.9	36.6		
28.0		36.7/27.2	32.9		32.2/27.0	35.3	32.8		31.3	35.1	32.3		31.6	34.6	31.9		31.7	33.7	31.0/28.6	
30.0			30.2	25.9/31.5		32.4	30.1		28.7/29.9	32.2	29.9		28.8	31.8	29.7		29.0	31.6	29.4	
32.0			27.8	25.3		32.3/30.1	27.7	23.7/33.5		29.7	27.5		26.5	29.0	27.5		26.6	29.3	27.4	
34.0			27.6/32.2	23.4			25.7	23.3		28.5/33.1	25.5	21.9/35.4	25.5/32.8	26.7	25.4		24.6	26.9	25.5	
36.0				21.8			24.7/35.1	21.6			23.7	21.4		24.2	23.7	20.3/37.4	22.9/35.8	24.8	23.7	
38.0				20.3				20.2			22.2	19.9			22.1	19.9		22.8	22.1	19.0/39.3
40.0				20.3/38.1				18.9			22.1/38.1	18.7			20.7	18.6		21.9/39.0	20.7	18.5
42.0								18.3/41.1					17.5		20.1/41.0	17.4			19.4	17.4
44.0													16.5			16.4			18.5	16.4
46.0																15.5				15.4
48.0																15.1/47.0				14.6
50.0																				13.9/49.9

■ w/36.55m Tower

Jib Length (m)	36.6				39.6				42.7				45.7				48.8			
Tower Angle (°)	88	83	75	65	88	83	75	65	88	83	75	65	88	83	75	65	88	83	75	65
Working radius(m)																				
14.0	45.2/14.4				39.1/15.3															
16.0	44.7				39.1				34.4/16.2				29.3/17.1				26.0/17.8			
18.0	43.5				37.9				33.9				29.2				26.0			
20.0	41.9	42.8/20.6			36.9	36.9/21.7			33.0				28.3				25.2			
22.0	40.1	40.1			36.1	36.7			32.1	32.4/22.9			27.6				24.5			
24.0	37.2	37.4			35.5	35.7			31.5	31.9			27.0	27.4			23.9	24.1/24.9		
26.0	34.4	34.7			33.8	33.7			30.4	30.8			26.5	26.7			23.4	23.7		
28.0	31.8	32.5			32.1	31.5			29.2	29.2			26.1	26.0			23.0	23.1		
30.0	28.9	30.5	28.8/30.2		29.3	29.8	27.1/31.7		27.5	27.7			25.1	25.5			22.7	22.5		
32.0	26.5	28.9	27.0		26.9	28.0	26.8		25.8	26.4	25.4/33.2		24.2	25.1			21.9	22.1		
34.0	24.5	26.8	25.3		24.6	26.6	25.1		24.4	25.2	24.7		23.2	24.1	24.0/34.7		21.3	21.3	21.5/35.9	
36.0	22.7	24.7	23.5		22.8	25.1	23.5		22.6	24.2	23.2		22.3	23.2	23.0		20.7	20.7	21.4	
38.0	21.1	22.9	21.9		21.2	23.2	22.0		21.0	23.0	21.7		21.3	22.1	21.7		20.3	20.2	21.0	
40.0	20.5/38.7	21.4	20.5	17.7/41.3	19.8	21.6	20.5		19.6	21.4	20.3		19.8	21.2	20.4		19.7	19.7	20.2	
42.0		19.8/41.9	19.3	17.2	18.7/41.7	20.1	19.3	16.5/43.3	18.3	20.0	19.1		18.5	19.8	19.1		18.4	19.3	19.0	
44.0			18.1	16.2		18.6	18.1	16.2	17.2	18.7	17.9	15.4/45.2	17.4	18.5	18.0		17.3	18.4	17.9	
46.0			17.1	15.3		18.1/44.8	17.1	15.2	16.8/44.6	17.5	16.9	15.0	16.3	17.3	16.9	14.4/47.2	16.2	17.2	16.8	
48.0			16.7/46.9	14.4		16.2	14.4		16.4/47.8	16.0	14.1	15.5/47.6	16.3	16.0	14.1	15.3	16.2	15.9	13.6/48.7	
50.0				13.6		15.4/49.8	13.6			15.1	13.4		15.1	15.1	13.4	14.4/49.8	15.2	15.0	13.2	
52.0				12.9			12.9			14.3	12.7		14.8/50.7	14.3	12.7		14.2	14.2	12.5	
54.0				12.7/52.9			12.2			14.1/52.8	12.0			13.6	12.0		13.7/53.0	13.5	11.9	
56.0							11.7/55.8				11.4			13.0/55.7	11.4			12.8	11.2	
58.0											10.8				10.8			12.2	10.7	
60.0											10.7/58.7				10.3				10.2	
62.0															9.8/61.7				9.7	
64.0																				9.2/63.9

■ w/36.55m Tower

Jib Length (m)	51.8				54.9				57.9				61.0			
Tower Angle (°)	88	83	75	65	88	83	75	65	88	83	75	65	88	83	75	65
Working radius(m)																
18.0	24.7/18.7				22.1/19.6											
20.0	24.3				21.9				19.4/20.5				17.0/21.3			
22.0	23.8				21.2				18.9				16.8			
24.0	23.1				20.6				18.2				16.2			
26.0	22.4	22.7			20.0	20.1/27.2			17.7				15.7			
28.0	21.7	22.0			19.4	19.8			17.2	17.5/28.3			15.3	15.3/29.5		
30.0	21.3	21.4			18.8	19.1			16.6	17.1			14.8	15.2		
32.0	20.9	20.9			18.5	18.6			16.2	16.4			14.3	14.7		
34.0	20.7	20.5			18.2	18.1			15.4	15.9			13.7	14.1		
36.0	20.5	20.2	20.4/37.4		18.0	17.8			14.6	15.4			13.0	13.7		
38.0	19.9	19.9	20.3		17.8	17.6	17.8/38.9		13.9	14.6			12.3	13.0		
40.0	19.5	19.4	19.8		17.8	17.4	17.5		13.2	13.8	15.4/40.5		11.7	12.3		
42.0	18.2	19.0	18.7		17.6	17.3	17.1		12.6	13.2	15.1		11.1	11.7	13.3	
44.0	17.1	18.2	17.6		17.0	17.1	16.8		12.1	12.6	14.6		10.6	11.1	13.0	
46.0	16.0	17.0	16.6		15.9	16.8	16.5		11.6	12.1	13.9		10.2	10.6	12.4	
48.0	15.1	16.0	15.7		15.0	15.9	15.6		11.2	11.6	13.3		9.7	10.2	11.7	
50.0	14.2	15.0	14.8	12.6/50.6	14.1	14.9	14.7		10.8	11.1	12.7		9.4	9.7	11.2	
52.0	13.4	14.2	14.0	12.3	13.3	14.1	13.9	11.9/52.6	10.5	10.8	12.1		9.0	9.4	10.7	
54.0	13.1/52.7	13.4	13.3	11.6	12.6	13.3	13.2	11.5	10.2	10.4	11.6	11.0/54.5	8.8	9.0	10.2	
56.0		12.5/55.9	12.6	11.0	12.0/55.7	12.6	12.5	10.9	10.0	10.2	11.2	10.7	8.5	8.8	9.8	10.3/56.5
58.0			12.0	10.5		11.8	11.9	10.4	9.8	10.0	10.8	10.1	8.3	8.5	9.4	10.0
60.0			11.4	9.9		11.5/58.9	11.3	9.8	9.7/58.6	9.8	10.5	9.6	8.2	8.3	9.1	9.5
62.0			11.2/60.9	9.4			10.8	9.4		9.7/61.8	10.2	9.1	8.1/61.6	8.2	8.8	9.0
64.0				9.0			10.3/63.9	8.9			10.0	8.7		8.1	8.6	8.5
66.0				8.6				8.5			9.7	8.3		8.1/64.8	8.4	8.1
68.0				8.4/66.9				8.1			9.5/66.8	7.9			8.2	7.7
70.0								7.7/69.8				7.5			8.2/69.7	7.4
72.0												7.2				7.0
74.0												7.0/72.8				6.7
76.0																6.4/75.7

■ w/39.60m Tower

Jib Length (m)	21.3				24.4				27.4				30.5				33.5			
Tower Angle (°)	88	83	75	65	88	83	75	65	88	83	75	65	88	83	75	65	88	83	75	65
Working radius(m)																				
10.0	76.8/10.1				67.5/11.0				58.0/11.9											
12.0	69.4				65.8				57.9				56.3/12.8				49.4/13.6			
14.0	66.5	65.0/15.3			63.2				55.7				56.3				49.4			
16.0	62.6	62.2			61.3	59.9/16.4			54.0	54.6/17.6			55.5				49.0			
18.0	54.7	55.5			55.5	54.6			52.8	53.9			53.1	50.2/18.7			48.0	47.0/19.8		
20.0	47.4	50.0			48.1	49.2			48.6	48.6			49.0	47.2			45.6	47.0		
22.0	41.8	45.6	39.6/23.3		42.4	44.8			42.8	44.3			43.2	42.5			43.4	42.0		
24.0	37.0	41.8	38.3		37.9	41.1	36.3/24.9		38.3	40.7			38.6	39.0			38.9	38.2		
26.0	36.9/24.1	38.7	35.3		34.1	38.0	34.7		34.5	37.5	33.8/26.4		34.9	36.0	31.5/27.9		35.1	35.3		
28.0		36.0/27.6	32.6		32.3/27.1	35.2	32.2		31.4	34.9	31.8		31.8	33.5	31.3		31.7	32.9	29.5/29.4	
30.0			29.9			32.3	29.8		28.7	32.4	29.7		29.1	31.5	29.1		29.4	30.7	28.8	
32.0			27.6	24.1/32.8		31.8/30.5	27.5			29.9	27.5		26.8	29.3	27.2		27.1	28.7	27.0	
34.0			26.5/33.0	23.0			25.5	22.1/34.8		28.4/33.4	25.5		25.8/32.9	27.0	25.3		25.0	26.9	25.3	
36.0				21.4			23.8/35.9	21.2			23.7	20.7/36.7		25.4	23.5		23.2/35.9	25.4	23.5	
38.0				19.9				19.8			22.1	19.7		24.1/36.4	21.9	19.0/38.7		23.7	21.9	
40.0				19.0/39.4				18.5			21.4/38.9	18.5			20.5	18.2		21.9/39.3	20.5	17.9/40.6
42.0								17.4				17.3			19.4/41.8	17.1			19.3	17.1
44.0								17.2/42.4				16.3				16.1			18.1	16.0
46.0												15.7/45.3				15.2			17.7/44.7	15.1
48.0																14.3				14.3
50.0																14.2/48.3				13.5
52.0																				13.1/51.2

■ w/39.60m Tower

Jib Length (m)	36.6				39.6				42.7				45.7				48.8			
Tower Angle (°)	88	83	75	65	88	83	75	65	88	83	75	65	88	83	75	65	88	83	75	65
Working radius(m)																				
14.0	43.7/14.5				39.0/15.4															
16.0	43.5				38.5				33.6/16.3				29.3/17.2				25.8/17.9			
18.0	42.8				37.2				32.6				28.9				25.7			
20.0	41.5	42.3/21.0			36.2				31.7				28.1				25.0			
22.0	40.1	39.7			35.5	36.5/22.1			30.9	31.1/23.3			27.3				24.3			
24.0	37.3	37.2			34.9	35.4			30.3	30.8			26.7	27.2/24.4			23.7	23.8/25.3		
26.0	34.5	34.6			34.5	34.6			29.9	30.0			26.2	26.5			23.2	23.5		
28.0	31.9	32.9			32.1	32.9			29.2	29.0			25.9	25.8			22.7	22.9		
30.0	29.0	30.7	27.1/31.0		29.3	30.7			27.3	27.5			25.1	25.3			22.4	22.4		
32.0	27.0	28.7	26.5		26.8	28.7	25.7/32.5		25.7	26.0			24.0	24.9			21.5	21.9		
34.0	24.9	26.9	24.9		24.7	26.9	24.5		24.3	24.6	24.3		23.0	23.7	22.8/35.5		20.8	21.1		
36.0	23.1	25.4	23.4		22.9	25.4	23.0		23.0	23.5	22.8		21.9	22.6	22.4		20.1	20.4	21.2/36.7	
38.0	21.5	23.7	21.8		21.3	23.7	21.6		21.6	22.6	21.5		21.0	21.6	21.1		19.6	19.7	20.7	
40.0	20.8/38.8	22.2	20.4		19.9	22.2	20.2		20.1	21.6	20.2		19.9	20.7	19.9		19.1	19.2	19.6	
42.0		20.9	19.2	16.6/42.6	18.8/41.8	20.9	19.0		18.8	20.1	19.0		18.6	20.0	18.8		18.5	18.7	18.5	
44.0		19.4/42.3	18.0	15.9		19.6	17.8	15.4/44.6	17.6	18.8	17.9		17.4	18.6	17.7		17.3	18.2	17.5	
46.0			17.0	15.0		19.0/45.2	16.8	14.7	17.1/44.7	17.6	16.8	14.6/46.5	16.4	17.5	16.6		16.3	17.4	16.5	
48.0			16.2/47.7	14.1			15.9	13.9		16.3	15.9	13.9	15.5/47.7	16.4	15.7	13.4/48.5	15.3	16.3	15.6	12.7/49.9
50.0				13.4			15.3	13.1		16.2/48.2	15.0	13.1		15.3	14.9	12.9	14.4/49.9	15.3	14.7	12.6
52.0				12.7			14.8/50.6	12.5			14.3	12.4		14.7/51.1	14.1	12.2		14.5	14.0	12.1
54.0				12.0				11.8			13.7/53.6	11.8			13.4	11.6		13.9/53.4	13.2	11.4
56.0				12.0/54.1				11.2				11.2			12.7	11.0			12.6	10.8
58.0								11.0/57.1				10.6			12.5/56.5	10.4			12.0	10.3
60.0												10.1				9.9			11.7/58.8	9.8
62.0																9.4				9.3
64.0																9.2/63.0				8.8
66.0																				8.6/65.2

■ w/39.60m Tower

Jib Length (m)	51.8				54.9				57.9				61.0			
	88	83	75	65	88	83	75	65	88	83	75	65	88	83	75	65
18.0	24.5/18.8				21.6/19.7											
20.0	24.0				21.6				19.2/20.6				16.8/21.5			
22.0	23.6				21.0				18.7				16.7			
24.0	22.9				20.4				18.1				16.1			
26.0	22.3	22.3/26.4			19.8	19.8/27.5			17.6				15.6			
28.0	21.5	21.7			19.3	19.6			17.1	17.3/28.7			15.1	15.2/29.8		
30.0	21.1	21.1			18.7	18.8			16.6	17.3			14.7	15.1		
32.0	20.8	20.7			18.3	18.3			16.1	16.5			14.2	14.7		
34.0	20.4	20.3			18.0	18.0			15.4	16.0			13.8	14.1		
36.0	19.9	19.9			17.8	17.7			14.6	15.5			13.0	13.6		
38.0	19.4	19.4	20.1/38.2		17.7	17.4	17.6/39.7		13.9	14.6			12.3	13.0		
40.0	18.9	18.8	19.2		17.4	17.3	17.6		13.2	13.9	15.2/41.2		11.7	12.3		
42.0	18.3	18.4	18.2		17.1	17.0	17.1		12.6	13.2	15.1		11.1	11.7	13.2/42.8	
44.0	17.1	18.0	17.2		16.8	16.6	16.8		12.1	12.6	14.7		10.6	11.2	13.0	
46.0	16.1	17.2	16.3		16.0	16.3	16.1		11.6	12.1	14.2		10.2	10.6	12.6	
48.0	15.1	16.1	15.4		15.0	16.0	15.3		11.2	11.6	13.5		9.7	10.2	12.0	
50.0	14.2	15.1	14.5	11.8/51.9	14.2	15.1	14.4		10.8	11.2	12.9		9.4	9.8	11.4	
52.0	13.4	14.3	13.7	11.7	13.4	14.2	13.7	11.0/53.9	10.4	10.8	12.3		9.0	9.4	10.8	
54.0	13.0/52.9	13.5	13.0	11.2	12.6	13.4	13.0	10.9	10.2	10.5	11.8	10.3/55.8	8.8	9.1	10.4	
56.0		12.5	12.4	10.6	11.9/55.8	12.7	12.3	10.5	10.0	10.2	11.4	10.2	8.5	8.8	9.9	9.6/57.8
58.0		12.4/56.3	11.8	10.1		11.9	11.7	10.0	9.8	10.0	10.9	9.7	8.3	8.5	9.5	9.5
60.0			11.2	9.5		11.5/59.2	11.1	9.5	9.7/58.7	9.8	10.6	9.2	8.2	8.3	9.2	9.1
62.0			10.7/61.7	9.1			10.6	9.0		9.7	10.3	8.8	8.1/61.7	8.2	8.9	8.6
64.0				8.6			10.1	8.5		9.7/62.2	9.9	8.3		8.1	8.6	8.2
66.0				8.2			9.9/64.7	8.1			9.4	7.9		8.1/65.1	8.4	7.8
68.0				7.8				7.7			9.1/67.6	7.5			8.2	7.4
70.0				7.8/68.2				7.4				7.2			8.2	7.0
72.0								7.2/71.1				6.8			8.1/70.5	6.7
74.0												6.5				6.4
76.0												6.5/74.1				6.1
78.0																5.9/77.0

■ w/42.65m Tower

Jib Length (m)	21.3				24.4				27.4				30.5				33.5			
	88	83	75	65	88	83	75	65	88	83	75	65	88	83	75	65	88	83	75	65
10.0	76.6/10.2				66.1/11.1															
12.0	72.9				64.7				57.4				52.8/12.9				45.3/13.8			
14.0	69.9	62.3/15.6			62.1				55.2				52.3				45.3			
16.0	64.4	60.8			60.3	57.2/16.8			53.5	53.1/17.9			51.5				45.1			
18.0	55.3	54.2			55.9	53.6			52.3	52.7			49.9	47.0/19.1			44.6			
20.0	47.9	48.9			48.5	48.4			48.9	47.6			47.9	45.2			43.4	44.0/20.2		
22.0	42.1	44.6			42.7	44.1			43.1	43.4			43.5	41.5			41.3	41.4		
24.0	37.4	41.0	37.1/24.1		38.1	40.5	34.4/25.6		38.5	39.8			38.8	37.3			38.0	37.2		
26.0	37.0/24.2	37.9	34.2		34.3	37.5	33.8		34.7	36.8	31.8/27.2		35.1	34.5			35.0	33.6		
28.0		35.3/27.9	31.7		32.3/27.2	34.8	31.3		31.6	34.2	30.9		31.9	32.2	29.6/28.7		31.8	31.1		
30.0			29.5			32.3	29.2		28.9	31.9	28.8		29.3	30.6	28.4		28.8	29.4	27.9/30.2	
32.0			27.1			31.2/30.9	27.1		28.7/30.1	29.7	26.9		27.0	28.9	26.5		27.2	28.0	26.1	
34.0			25.4/33.8	22.1/34.1			25.1			27.8/33.8	25.0		25.8/33.1	27.4	24.8		25.2	26.7	24.5	
36.0				20.7			23.4	20.5			23.3			25.5	23.2		23.5	25.5	23.1	
38.0				19.3			22.8/36.7	19.2			21.7	19.1		24.8/36.8	21.6			23.7	21.5	
40.0				18.0				17.9			20.6/39.6	17.9			20.3	17.6		22.0/39.7	20.2	16.5/41.9
42.0				17.6/40.7				16.8				16.8			19.0	16.5			18.9	16.5
44.0								15.2/43.7				15.8			18.6/42.6	15.5			17.8	15.5
46.0												14.9			14.6				17.1/45.5	14.6
48.0												14.6/46.6			13.8					13.8
50.0															13.2/49.5					13.0
52.0																				12.3
54.0																				12.2/52.5

■ w/42.65m Tower

Jib Length (m)	36.6				39.6				42.7				45.7				48.8			
	88	83	75	65	88	83	75	65	88	83	75	65	88	83	75	65	88	83	75	65
14.0	412/146				37.0/155															
16.0	41.1				37.0				32.9/16.4				28.8/17.3							
18.0	40.5				36.6				32.8				28.6				25.5			
20.0	39.8	40.3/21.3			36.1				32.2				27.8				24.7			
22.0	38.4	39.3			35.3	35.9/22.5			31.4	31.7/23.6			27.0				24.0			
24.0	36.2	36.8			34.4	35.1			30.8	31.4			26.4	26.7/24.8			23.4	23.5/25.6		
26.0	33.9	33.5			32.9	33.4			29.9	30.5			25.9	26.3			22.9	23.4		
28.0	31.6	30.6			31.4	30.3			28.8	28.9			25.6	25.6			22.5	22.7		
30.0	29.0	28.7	26.1/31.7		29.3	27.8			27.2	27.4			25.1	25.1			22.2	22.2		
32.0	27.0	27.2	25.7		27.0	26.0	24.2/33.3		25.5	25.5			24.0	24.7			21.5	21.7		
34.0	25.3	25.8	24.1		24.7	24.8	23.7		24.0	23.9	22.6/34.8		22.9	23.5			20.6	21.0		
36.0	23.4	24.6	22.7		23.3	23.6	22.3		22.7	22.8	21.8		21.8	22.1	21.6/36.3		19.8	20.1	20.3/37.5	
38.0	21.8	23.6	21.4		21.9	22.7	21.0		21.5	21.9	20.6		20.8	20.9	20.5		19.1	19.2	20.1	
40.0	21.0/38.9	22.0	20.0		20.5	22.1	19.8		20.2	21.1	19.4		19.7	20.0	19.3		18.5	18.5	19.0	
42.0		20.3	18.8	15.3/43.9	19.2/41.9	20.7	18.6		18.9	20.4	18.4		18.9	19.4	18.3		18.0	18.0	18.0	
44.0		19.8/42.6	17.7	15.3		19.4	17.5	14.3/45.8	17.8	19.2	17.3		17.7	18.7	17.3		17.6	17.5	17.1	
46.0			16.7	14.4		17.8/45.6	16.5	14.2	17.4/44.8	18.0	16.3	13.3/47.8	16.6	17.8	16.3		16.5	17.2	16.2	
48.0			15.8	13.6			15.6	13.4		16.7	15.4	13.1	15.7/47.8	16.7	15.4	12.4/49.8	15.5	16.6	15.3	
50.0			15.5/48.5	12.9			14.7	12.6		16.4/48.5	14.5	12.4		15.7	14.6	12.4	14.6	15.6	14.4	11.7/51.2
52.0				12.2			14.2/51.4	12.0			13.8	11.7		14.9/51.5	13.8	11.7		14.7	13.7	11.6
54.0				11.6				11.3			13.1	11.1			13.1	11.1		13.8/53.7	13.0	11.0
56.0					11.1/55.4			10.8			13.0/54.4	10.5			12.4	10.5			12.3	10.4
58.0								10.2				10.0			12.0/57.3	10.0			11.7	9.9
60.0									10.2/58.4						9.5				11.2/59.6	9.4
62.0													9.2/61.3							8.9
64.0																				8.5
66.0																8.5/64.3				8.1
68.0																				8.0/66.5

■ w/42.65m Tower

Jib Length (m)	51.8				54.9				57.9				61.0			
	88	83	75	65	88	83	75	65	88	83	75	65	88	83	75	65
18.0	24.2/18.9				21.3/19.8											
20.0	23.8				21.3				18.8/20.7				16.7/21.6			
22.0	23.0				20.9				18.6				16.5			
24.0	22.7				20.2				18.0				16.0			
26.0	22.1	22.1/26.8			19.7	19.5/27.9			17.4				15.5			
28.0	21.3	21.5			19.2	19.4			16.9	17.2/29.1			15.0			
30.0	20.9	21.0			18.5	18.7			16.5	17.0			14.6	15.0/30.2		
32.0	20.4	20.5			18.1	18.2			15.9	16.4			14.1	14.6		
34.0	19.7	19.9			17.9	17.8			15.4	15.8			13.7	14.0		
36.0	19.2	19.2			17.6	17.5			14.6	15.4			13.0	13.5		
38.0	18.7	18.7	19.0/39.0		17.3	17.3			13.9	14.7			12.3	13.1		
40.0	18.2	18.2	18.6		16.9	16.8	17.4/40.5		13.2	14.0			11.7	12.4		
42.0	17.9	17.7	17.6		16.5	16.4	17.1		12.6	13.3	15.0		11.1	11.8	13.0/43.6	
44.0	17.4	17.3	16.7		16.2	16.0	16.5		12.1	12.7	14.7		10.6	11.2	12.9	
46.0	16.3	17.0	15.8		15.9	15.7	15.6		11.6	12.1	14.4		10.2	10.7	12.6	
48.0	15.3	16.4	15.0		15.2	15.4	14.8		11.2	11.7	13.7		9.7	10.2	12.2	
50.0	14.4	15.4	14.2		14.4	15.2	14.1		10.8	11.2	13.1		9.4	9.8	11.6	
52.0	13.6	14.5	13.5	10.9/53.2	13.6	14.5	13.4		10.4	10.8	12.5		9.0	9.4	11.0	
54.0	13.2/53.0	13.7	12.8	10.7	12.8	13.6	12.7	10.2/55.2	10.2	10.5	12.0		8.8	9.1	10.5	
56.0		12.8	12.1	10.1	12.1/55.9	12.9	12.0	10.0	9.9	10.2	11.5	9.4/57.1	8.5	8.8	10.1	
58.0		12.5/56.7	11.5	9.6		12.2	11.4	9.5	9.8	10.0	11.1	9.3	8.3	8.5	9.7	8.8/59.1
60.0			10.9	9.1		10.6/59.6	10.9	9.0	9.7/58.8	9.8	10.7	8.8	8.2	8.3	9.3	8.6
62.0			10.4	8.7			10.3	8.6		9.7	10.1	8.3	8.1/61.8	8.2	9.0	8.2
64.0			10.3/62.5	8.2			9.9	8.1		9.7/62.6	9.7	7.9		8.1	8.7	7.8
66.0				7.8			9.6/65.4	7.7			9.2	7.5		8.0/65.5	8.5	7.4
68.0				7.5				7.4			8.8	7.1			8.3	7.0
70.0				7.2/69.4				7.0			8.7/68.4	6.8			8.2	6.6
72.0								6.7				6.5			8.0/71.3	6.3
74.0								6.6/72.4				6.2				6.0
76.0												6.0/75.3				5.7
78.0																5.4
80.0																5.4/78.3

■ w/45.70m Tower

Jib Length (m)	21.3				24.4				27.4				30.5				33.5			
Tower Angle (°)	88	83	75	65	88	83	75	65	88	83	75	65	88	83	75	65	88	83	75	65
Working radius(m)																				
10.0	75.0/10.3				65.3/11.2															
12.0	71.8				64.1				56.7/12.1				49.1/13.0				41.3/13.9			
14.0	67.4				61.6				54.6				48.4				40.5			
16.0	62.9	59.6			59.8	54.8/17.2			52.9				47.5				40.5			
18.0	55.7	53.2			55.9	52.4			51.8	50.6/18.3			46.7	43.8/19.4			40.5			
20.0	48.2	48.1			48.8	47.4			49.3	46.6			45.9	43.2			40.5	41.1/20.6		
22.0	42.4	43.9			42.9	43.2			43.4	42.5			43.8	41.3			39.2	41.1		
24.0	37.7	40.3	34.1/24.9		38.3	39.7			38.7	39.0			39.1	37.1			37.1	37.1		
26.0	37.0/24.3	37.3	33.3		34.5	36.7	32.4/26.4		34.9	36.0			35.2	33.5			35.0	33.5		
28.0		34.8	30.9		32.3/27.3	34.1	30.4		31.7	33.5	29.9		32.1	31.0	28.0/29.5		31.9	30.6		
30.0		34.5/28.3	28.8			31.9	28.3		29.0	31.3	27.9		29.1	29.0	27.5		29.1	28.5	26.3/31.0	
32.0			26.8			30.6/31.2	26.5		28.7/30.2	29.4	26.1		27.1	27.6	25.7		26.8	26.8	25.3	
34.0			24.8	20.6/35.4			24.7			27.3	24.5		25.8/33.2	26.4	24.1		25.3	25.6	23.8	
36.0			24.3/34.5	20.1			23.0	19.0/37.3		27.1/34.2	22.9			25.5	22.7		23.6	24.5	22.4	
38.0				18.7			21.8/37.5	18.6			21.3	17.6/39.3		24.5/37.1	21.2		23.5/36.1	23.7	21.1	
40.0				17.5				17.3			20.0	17.2			19.9	16.3/41.3		22.2	19.8	
42.0				16.4				16.3			19.7/40.4	16.2			18.7	16.0		22.1/40.1	18.6	15.3/43.2
44.0								15.3				15.2			17.8/43.4	15.0			17.5	14.9
46.0								14.8/44.9				14.3				14.1			16.5	14.0
48.0												13.6/47.9				13.3			16.4/46.3	13.3
50.0																12.6				12.5
52.0																12.3/50.8				11.9
54.0																				11.3/53.8

■ w/45.70m Tower

Jib Length (m)	36.6				39.6				42.7				45.7				48.8			
Tower Angle (°)	88	83	75	65	88	83	75	65	88	83	75	65	88	83	75	65	88	83	75	65
Working radius(m)																				
14.0	38.5/14.7				35.9/15.6															
16.0	38.5				35.9				32.2/16.5				28.4/17.4							
18.0	38.4				35.5				31.9				28.3				25.2/18.1			
20.0	38.2	38.3/21.7			34.6				31.0				27.5				24.5			
22.0	36.8	38.0			33.9	34.4/22.9			30.2				26.7				23.7			
24.0	35.1	36.4			33.2	33.8			29.6	30.3			26.1	26.5/25.1			23.1			
26.0	33.4	33.3			31.9	33.0			29.2	29.5			25.6	26.1			22.6	23.2		
28.0	31.3	30.3			30.7	30.1			28.5	28.8			25.2	25.4			22.2	22.6		
30.0	29.1	27.8			29.3	27.7			27.2	27.4			25.0	24.9			21.9	22.0		
32.0	26.5	26.0	24.6/32.5		27.1	25.7			25.5	25.5			24.0	24.4			21.4	21.5		
34.0	24.7	24.5	23.4		24.8	24.1	23.2/34.1		23.8	23.5	21.7/35.6		22.9	23.4			20.6	20.8		
36.0	23.4	23.5	22.0		23.2	22.7	21.9		22.3	22.1	21.4		21.8	21.9	20.4/37.1		19.8	19.6		
38.0	21.8	22.8	20.8		21.8	21.9	20.6		21.0	21.0	20.2		20.8	20.5	19.8		19.0	18.6	19.2/38.2	
40.0	21.0/39.0	22.1	19.6		20.6	21.3	19.5		20.1	20.2	19.1		19.6	19.3	18.7		18.3	17.8	18.4	
42.0		20.6	18.5		19.3	20.6	18.5		19.1	19.5	18.1		18.6	18.5	17.7		17.7	17.2	17.4	
44.0		19.9/43.0	17.4	14.2/45.2		19.5	17.4		17.9	19.0	17.2		17.7	18.0	16.8		17.1	16.7	16.5	
46.0			16.4	13.9		18.0	16.4	13.5/47.1	17.3/44.9	18.1	16.2		16.6	17.5	15.9		16.5	16.5	15.7	
48.0			15.5	13.1		15.5	13.1		16.8	15.3	12.4/49.1	15.7/47.9	16.8	15.1			15.6	16.1	14.9	
50.0			14.9/49.3	12.4		14.7	12.4		16.3/48.9	14.5	12.1		15.8	14.3	11.5/51.1		14.7	15.7	14.1	
52.0				11.7		13.9	11.7			13.7	11.5			14.5/51.9	13.5	11.2	14.6/50.1	14.8	13.4	10.8/52.5
54.0				11.1		13.8/52.2	11.1			13.0	10.9				12.8	10.6		13.9	12.7	10.5
56.0				10.5			10.5			12.6/55.2	10.3				12.2	10.1		13.8/54.1	12.0	9.9
58.0				10.3/56.7			10.0				9.8				11.5	9.6			11.4	9.4
60.0							9.6/59.7				9.3				11.5/58.1	9.1			10.9	8.9
62.0											8.8					8.6			10.8/60.3	8.5
64.0											8.7/62.6					8.2				8.1
66.0																7.8/65.6				7.7
68.0																				7.3/67.8

■ w/45.70m Tower

Jib Length (m)	51.8				54.9				57.9				61.0			
	88	83	75	65	88	83	75	65	88	83	75	65	88	83	75	65
18.0	24.0/19.0				21.1/19.9											
20.0	23.6				21.1				18.5/20.8				16.6/21.7			
22.0	22.8				20.4				18.3				16.4			
24.0	22.2				20.0				17.8				15.8			
26.0	21.9	21.2/27.1			19.5				17.3				15.3			
28.0	21.0	21.2			19.0	19.2/28.3			16.8	17.0/29.4			14.9			
30.0	20.3	20.1			18.3	18.7			16.4	16.9			14.5	14.9/30.6		
32.0	19.6	19.5			18.0	18.1			15.8	16.4			14.1	14.5		
34.0	19.0	19.1			17.6	17.7			15.5	15.7			13.6	14.0		
36.0	18.4	18.5			17.1	17.2			14.7	15.2			13.0	13.5		
38.0	17.9	17.9	18.0/39.8		16.6	16.7			13.9	14.8			12.3	13.1		
40.0	17.5	17.4	17.9		16.2	16.2	17.0/41.3		13.2	14.1			11.7	12.5		
42.0	17.1	17.0	17.0		15.9	15.8	16.8		12.6	13.4	14.9/42.8		11.2	11.8		
44.0	16.8	16.6	16.1		15.6	15.4	15.9		12.1	12.8	14.7		10.6	11.3	12.9/44.3	
46.0	16.3	16.2	15.3		15.3	15.1	15.1		11.6	12.2	14.3		10.2	10.7	12.6	
48.0	15.4	15.9	14.5		15.1	14.8	14.3		11.2	11.7	14.0		9.7	10.3	12.3	
50.0	14.5	15.5	13.8		14.4	14.6	13.6		10.8	11.2	13.3		9.4	9.8	11.8	
52.0	13.6	14.6	13.2		13.6	14.4	13.0		10.4	10.9	12.6		9.0	9.4	11.2	
54.0	13.2/53.1	13.8	12.5	10.0/54.5	12.8	13.7	12.4		10.2	10.5	12.1		8.7	9.1	10.7	
56.0		13.0	11.8	9.7	12.1	13.0	11.7	9.4/56.4	9.9	10.2	11.5		8.5	8.8	10.2	
58.0		12.6/57.0	11.2	9.2		12.3	11.1	9.1	9.8	10.0	10.9	8.7/58.4	8.3	8.5	9.8	
60.0			10.7	8.7		11.3	10.6	8.6	9.7/59.0	9.8	10.4	8.4	8.2	8.3	9.4	8.0/60.4
62.0			10.2	8.2			10.1	8.1		9.7	9.9	7.9	8.1/61.9	8.3	9.1	7.7
64.0			9.8/63.3	7.8			9.6	7.7		9.7/62.9	9.4	7.5		8.1	8.8	7.3
66.0				7.4			9.2	7.3			9.0	7.1		8.1/65.9	8.5	7.0
68.0				7.1			9.1/66.2	7.0			8.5	6.8			8.3	6.6
70.0				6.7				6.6			8.3/69.2	6.4			8.0	6.3
72.0				6.6/70.7				6.3				6.1			7.7	5.9
74.0								6.1/73.7				5.8			7.6/72.1	5.6
76.0												5.5				5.4
78.0												5.4/76.6				5.1
80.0																4.9/79.6

■ w/48.75m Tower

Jib Length (m)	21.3				24.4				27.4				30.5				33.5				
	88	83	75	65	88	83	75	65	88	83	75	65	88	83	75	65	88	83	75	65	
10.0	71.9/10.4				64.6/11.3																
12.0	67.1				63.6				56.0/12.2				46.7/13.1								
14.0	62.1				59.6				54.1				46.4				40.5				
16.0	58.2	56.8/16.4			55.7	52.7/17.5			52.4				45.9				40.5				
18.0	54.8	52.0			52.6	51.2			50.2	48.5/18.7			45.6	42.3/19.8			40.5				
20.0	48.6	47.0			49.2	46.3			47.7	45.5			43.6	42.1			40.3	40.8/20.9			
22.0	42.7	42.9			43.2	42.2			43.7	41.5			41.5	41.0			37.7	40.1			
24.0	37.9	39.4	32.6/25.7		38.5	38.8			38.9	38.1			38.6	36.9			35.2	36.8			
26.0	37.0/24.4	36.5	32.2		34.7	35.9	29.7/27.2		35.1	35.3			35.4	33.3			33.1	33.3			
28.0		34.1	29.8		32.3/27.4	33.4	29.4		31.9	32.8	28.3/28.7		32.2	30.3			30.3	30.3			
30.0		33.4/28.7	27.8			31.3	27.3		29.1	30.6	27.0		28.8	27.8	26.3/30.3		27.9	27.8	24.7/31.8		
32.0			26.0			29.8/31.6	25.6		28.7/30.3	28.7	25.2		25.8	25.8	24.8		25.6	25.8	24.5		
34.0			24.3				24.0			27.1	23.7		24.9/33.3	24.6	23.2		24.3	24.4	23.0		
36.0			23.1/35.3	18.9/36.7			22.5			26.6/34.6	22.3			24.2	21.9		23.3	23.2	21.6		
38.0				18.0			21.0	17.5/38.6			20.9			24.0/37.5	20.6		23.2/36.2	22.4	20.4		
40.0				16.8			20.7/38.3	16.6			19.6	16.2/40.6			19.5			21.9	19.3		
42.0				15.8				15.6			18.9/41.2	15.5			18.3	15.1/42.5		21.7/40.4	18.2		
44.0				15.1/43.3				14.7				14.6				17.2	14.4		17.1	14.2/44.5	
46.0								13.8				13.7			17.0/44.2	13.5			16.1	13.5	
48.0								13.7/46.2				13.0				12.7			15.6/47.1	12.7	
50.0												12.5/49.2				12.0				12.0	
52.0																11.4				11.4	
54.0																11.3/52.1				10.8	
56.0																					10.4/55.1

■ w/48.75m Tower

Jib Length (m)	36.6				39.6				42.7				45.7				48.8			
Tower Angle (°)	88	83	75	65	88	83	75	65	88	83	75	65	88	83	75	65	88	83	75	65
Working radius(m)																				
14.0	37.9/14.9				34.5/15.7															
16.0	37.9				34.5				31.1/16.6				27.6/17.5							
18.0	37.7				34.2				30.9				27.6				24.1/18.2			
20.0	37.1				33.8				30.6				27.1				24.1			
22.0	35.4	37.6/22.1			33.2	34.0/23.2			29.9				26.4				23.5			
24.0	33.8	35.7			32.4	33.6			29.3	29.9/24.4			25.8	26.2/25.5			22.9			
26.0	32.2	33.1			31.3	32.2			28.8	29.2			25.3	25.9			22.4	22.9/26.4		
28.0	29.9	30.1			29.6	29.9			27.7	28.4			24.9	25.2			22.0	22.4		
30.0	28.0	27.6			28.0	27.5			26.5	27.0			24.7	24.6			21.7	21.8		
32.0	25.9	25.6	23.2/33.3		26.1	25.5			24.9	25.1			23.9	24.2			21.4	21.3		
34.0	24.0	23.8	22.6		24.2	23.5	22.0/34.8		23.5	23.4			22.9	23.2			20.4	20.7		
36.0	22.6	22.5	21.3		22.6	22.0	21.1		22.2	21.8	20.5/36.4		21.8	21.7	19.2/37.9		19.3	19.4		
38.0	21.5	21.6	20.0		21.2	20.7	19.9		20.9	20.3	19.5		20.8	20.1	19.1		18.3	18.2	18.1/39.0	
40.0	21.2/39.2	20.9	18.9		20.2	19.8	18.9		19.8	19.1	18.5		19.5	18.8	18.0		17.5	17.2	17.7	
42.0		20.6	18.0		19.3	19.4	17.9		18.8	18.5	17.5		18.4	17.8	17.1		16.8	16.4	16.8	
44.0		19.7/43.4	17.0		19.2/42.1	19.1	17.0		18.0	18.0	16.6		17.6	17.0	16.2		16.3	15.8	15.9	
46.0			16.0	13.1/46.5		18.3	16.1		17.7/45.0	17.6	15.8		16.7	16.6	15.4		15.9	15.3	15.1	
48.0			15.1	12.5		18.1/46.3	15.2	12.4/48.4		17.0	15.0		15.7	16.2	14.6		15.6	15.1	14.4	
50.0			14.3	11.8			14.3	11.9		16.6/49.3	14.2	11.4/50.4		16.0	13.9		14.7	14.9	13.7	
52.0			14.3/50.1	11.2			13.6	11.2			13.4	11.0		15.2	13.2	10.7/52.3	14.6/50.2	14.9	13.0	10.0/53.8
54.0				10.6			13.3/53.0	10.6			12.7	10.4		15.0/52.2	12.5	10.1		13.8	12.4	9.9
56.0				10.1				10.1			12.1/55.9	9.8			11.9	9.6		13.6/54.5	11.7	9.4
58.0				9.5				9.5				9.3			11.3	9.1			11.2	8.9
60.0								9.1				8.8			11.0/58.9	8.6			10.6	8.5
62.0								8.9/61.0				8.4				8.2			10.3/61.1	8.0
64.0												8.0/63.9				7.8				7.6
66.0																7.4				7.3
68.0																7.2/66.8				6.9
70.0																				6.7/69.1

■ w/48.75m Tower

Jib Length (m)	51.8				54.9				57.9				61.0			
Tower Angle (°)	88	83	75	65	88	83	75	65	88	83	75	65	88	83	75	65
Working radius(m)																
18.0	23.7/19.1															
20.0	23.3				20.6				18.3/20.9				16.2/21.8			
22.0	22.6				20.2				18.0				16.2			
24.0	21.9				19.6				17.6				15.7			
26.0	21.3	21.0/27.5			19.2				17.1				15.2			
28.0	20.7	21.0			18.8	19.1/28.7			16.6	16.9/29.8			14.7			
30.0	19.8	19.9			18.1	18.6			16.2	16.8			14.3	14.7/30.9		
32.0	18.8	19.0			17.4	17.7			15.6	16.3			14.0	14.5		
34.0	18.1	18.2			16.9	17.0			15.3	15.7			13.5	13.9		
36.0	17.6	17.6			16.4	16.4			14.7	15.1			13.1	13.3		
38.0	17.1	17.1			15.9	15.9			13.9	14.7			12.4	13.0		
40.0	16.6	16.6	16.9/40.6		15.5	15.5			13.3	14.1			11.7	12.6		
42.0	16.2	16.1	16.4		15.1	15.0	16.0/42.1		12.7	13.4	14.6/43.6		11.2	11.9		
44.0	15.9	15.7	15.5		14.8	14.7	15.3		12.1	12.8	14.6		10.6	11.3	12.7/45.1	
46.0	15.6	15.4	14.7		14.6	14.3	14.5		11.6	12.2	14.1		10.2	10.8	12.6	
48.0	15.4	15.1	14.0		14.3	14.1	13.8		11.2	11.7	13.4		9.8	10.3	12.3	
50.0	14.5	14.8	13.3		14.1	13.8	13.1		10.8	11.3	12.8		9.4	9.9	12.0	
52.0	13.7	14.7	12.7		13.6	13.6	12.5		10.4	10.9	12.1		9.0	9.5	11.4	
54.0	13.2/53.2	13.9	12.1	9.1/55.8	12.9	13.5	11.9		10.1	10.5	11.6		8.7	9.1	10.9	
56.0		13.0	11.5	9.0	12.2	13.1	11.4	8.5/57.7	9.9	10.2	11.0		8.5	8.8	10.4	
58.0		12.5/57.4	11.0	8.7	12.1/56.1	12.3	10.9	8.4	9.8	10.0	10.5	7.8/59.7	8.3	8.6	9.9	
60.0			10.4	8.2		11.3	10.3	8.1	9.7/59.1	9.8	10.1	7.7	8.1	8.3	9.5	7.2/61.6
62.0			9.9	7.8		11.2/60.4	9.8	7.7		9.6	9.6	7.4	8.1	8.2	9.2	7.1
64.0			9.4	7.4			9.3	7.3		9.5/63.3	9.2	7.0		8.1	8.9	6.8
66.0			9.4/64.1	7.0			8.9	6.9			8.7	6.7		7.7	8.6	6.5
68.0				6.7			8.7/67.0	6.6			8.3	6.3		7.7/66.2	8.2	6.2
70.0				6.3				6.2			7.9	6.0			7.8	5.9
72.0				6.0				5.9				5.7		7.4	5.6	
74.0								5.6				5.4		7.3/72.9	5.3	
76.0								5.5/75.0				5.1			5.0	
78.0												4.9/77.9			4.7	
80.0															4.5	
82.0															4.4/80.9	

■ w/51.80m Tower

Jib Length (m)	21.3				24.4				27.4				30.5				33.5				
	Tower Angle (°)	88	83	75	65	88	83	75	65	88	83	75	65	88	83	75	65	88	83	75	65
Working radius(m)	88	83	75	65	88	83	75	65	88	83	75	65	88	83	75	65	88	83	75	65	
10.0	66.2/10.5				60.9/11.4																
12.0	61.7				59.4				54.3/12.3				44.5/13.2								
14.0	57.0				54.9				52.3				40.5				41.3/14.1				
16.0	53.2	54.3/16.8			51.2	50.3/17.9			48.9				40.5				40.5				
18.0	50.2	50.9			48.2	50.1			46.1	46.7/19.0			40.5				40.3				
20.0	47.6	46.0			45.8	45.3			43.7	44.9			40.2	40.9/20.2			38.3	38.2/21.3			
22.0	42.9	42.0			43.5	41.3			41.8	40.9			38.4	39.1			36.3	37.4			
24.0	38.1	38.6			38.7	38.0			39.2	37.7			36.1	36.7			33.5	35.4			
26.0	37.0/24.5	35.7	30.7/26.5		34.8	35.2			35.3	34.8			33.5	33.1			31.2	33.1			
28.0		33.3	29.0		32.3/27.5	32.7	28.5		32.0	32.4	26.9/29.5		31.1	30.1			28.9	30.1			
30.0		32.3/29.0	27.0			30.6	26.6		29.3	30.3	26.3		28.6	27.6	24.8/31.1		27.0	27.6			
32.0			25.3			28.8	24.8		28.7/30.4	28.4	24.6		26.0	25.6	24.1		25.2	25.6	23.3/32.6		
34.0			23.8				23.3			26.8	23.1		24.4/33.4	23.6	22.6		23.6	23.6	22.5		
36.0			22.3				22.0			26.2/34.9	21.7			22.4	21.2		22.2	22.1	21.1		
38.0			22.2/36.1	17.5			20.7	16.1/39.9			20.5			20.8/37.9	20.1		21.6/36.3	20.8	19.9		
40.0				16.3			19.9/39.1	16.1			19.4	15.1/41.9			19.0			20.3	18.8		
42.0				15.3				15.1			18.2	15.1			18.0	14.0/43.8		20.2/40.8	17.9		
44.0				14.4				14.2				14.2			16.9	13.9			16.9	13.0/45.8	
46.0				14.1/44.6				13.4				13.3			16.3/45.0	13.1			16.0	12.9	
48.0								12.8/47.5				12.6				12.3			15.0/47.9	12.2	
50.0												11.9				11.6				11.5	
52.0												11.7/50.5				11.0				10.9	
54.0																10.5/53.4				10.3	
56.0																				9.8	
58.0																				9.7/56.4	

■ w/51.80m Tower

Jib Length (m)	36.6				39.6				42.7				45.7				48.8				
	Tower Angle (°)	88	83	75	65	88	83	75	65	88	83	75	65	88	83	75	65	88	83	75	65
Working radius(m)	88	83	75	65	88	83	75	65	88	83	75	65	88	83	75	65	88	83	75	65	
14.0	37.3/15.0				33.3/15.9																
16.0	37.3				33.3				29.9/16.7				26.7/17.6								
18.0	37.1				32.9				29.7				26.7				24.1/18.3				
20.0	36.0				32.5				29.4				26.4				23.9				
22.0	34.1	35.1/22.5			32.1	32.0/23.6			29.1				26.1				23.2				
24.0	32.6	33.7			31.2	31.6			28.7	29.5/24.7			25.5	25.7/25.9			22.6				
26.0	31.0	32.2			30.1	30.2			28.1	28.6			25.0	25.7			22.1	22.6/26.7			
28.0	28.7	29.9			28.6	29.0			26.9	27.4			24.6	25.0			21.7	22.2			
30.0	26.9	27.5			26.8	27.4			25.9	26.4			24.3	24.4			21.4	21.6			
32.0	25.2	25.5			25.1	25.3			24.5	24.8			23.9	23.9			21.2	21.1			
34.0	23.6	23.5	21.9/34.1		23.6	23.4	20.8/35.6		23.2	23.2			22.9	23.1			20.2	20.6			
36.0	21.4	21.9	20.6		22.3	21.8	20.5		22.0	21.7	19.3/37.2		21.9	21.6			19.2	19.3			
38.0	20.0	20.6	19.4		21.0	20.2	19.3		20.9	20.1	18.9		20.9	20.0	18.1/38.7		18.3	18.1	17.1/39.8		
40.0	19.7/39.3	19.6	18.3		19.6	19.0	18.3		19.4	18.9	17.8		19.5	18.8	17.4		17.3	17.1	17.0		
42.0		19.1	17.4		18.6	18.3	17.3		18.0	17.8	16.9		18.3	17.6	16.5		16.4	16.2	16.7		
44.0		19.0/43.8	16.5		18.3/42.2	17.8	16.4		17.1	17.0	16.0		17.1	16.6	15.6		15.7	15.6	15.8		
46.0			15.7	12.2/47.7		17.4	15.6		16.9/45.1	16.6	15.2		16.2	15.8	14.9		15.2	15.1	15.0		
48.0			14.8	12.0		17.3/46.7	14.9	11.5/49.7		16.4	14.5		15.7	15.4	14.1		14.8	14.7	14.2		
50.0			14.0	11.3			14.1	11.4		16.3/49.7	13.8	10.5/51.7	15.6/48.1	15.0	13.5		14.6	14.4	13.5		
52.0			13.7/50.8	10.7			13.3	10.7				13.1	10.5		14.6	12.8	9.8/53.6	14.4/50.3	14.2	12.7	
54.0				10.1			12.7/53.8	10.2				12.4	9.9		14.4/52.6	12.2	9.6		13.9	12.1	9.0/55.1
56.0				9.6				9.6				11.8	9.4			11.6	9.1		13.5/54.8	11.6	8.9
58.0				9.1				9.1				11.6/56.7	8.9			11.0	8.7		11.0	8.5	
60.0				8.9/59.3				8.7					8.4			10.6/59.7	8.2		10.5	8.1	
62.0								8.2					8.0				7.8		10.0/61.9	7.6	
64.0								8.2/62.2					7.6				7.4			7.2	
66.0													7.4/65.2				7.0			6.9	
68.0																	6.7			6.5	
70.0																	6.6/68.1			6.2	
72.0																				6.1/70.4	

■ w/51.80m Tower

Jib Length (m) Tower Angle (°) Working radius(m)	51.8				54.9				57.9				61.0			
	88	83	75	65	88	83	75	65	88	83	75	65	88	83	75	65
18.0	23.4/19.2															
20.0	23.1				20.7/20.1				18.1/21.0				16.0/21.9			
22.0	22.0				20.0				17.8				16.0			
24.0	21.0				19.4				17.3				15.6			
26.0	20.7	20.9/27.9			18.8				16.9				15.0			
28.0	20.4	20.9			18.5	19.0/29.0			16.5				14.6			
30.0	19.7	19.8			18.0	18.5			16.1	16.7/30.2			14.2	14.5/31.3		
32.0	18.7	18.9			17.2	17.6			15.6	16.2			13.8	14.4		
34.0	17.8	18.0			16.4	16.7			14.9	15.5			13.3	13.9		
36.0	17.0	17.1			15.9	15.9			14.4	14.7			13.1	13.3		
38.0	16.4	16.4			15.3	15.2			13.9	14.1			12.4	12.9		
40.0	15.8	15.7	16.0/41.3		14.7	14.7			13.3	13.6			11.7	12.5		
42.0	15.4	15.2	15.8		14.4	14.3	15.1/42.9		12.7	13.2			11.2	12.0		
44.0	15.0	14.8	15.0		14.1	13.9	14.7		12.1	12.8	14.2/44.4		10.6	11.4	12.6/45.9	
46.0	14.7	14.5	14.2		13.8	13.6	14.0		11.6	12.3	13.6		10.2	10.8	12.5	
48.0	14.5	14.2	13.5		13.5	13.3	13.3		11.2	11.8	12.9		9.8	10.3	12.2	
50.0	14.3	13.9	12.8		13.4	13.0	12.6		10.8	11.3	12.3		9.4	9.9	12.0	
52.0	13.7	13.7	12.2		13.2	12.8	12.0		10.4	10.9	11.7		9.0	9.5	11.4	
54.0	13.1/53.3	13.6	11.6		12.9	12.7	11.5		10.1	10.6	11.1		8.7	9.1	10.9	
56.0		13.2	11.1	8.3/57.1	12.2	12.6	10.9		9.9	10.2	10.6		8.5	8.8	10.3	
58.0		12.8/57.8	10.6	8.1	12.1/56.2	12.4	10.4	7.7/59.0	9.8	10.0	10.1		8.3	8.6	9.9	
60.0			10.2	7.7		11.7	10.0	7.5	9.7/59.2	9.8	9.7	7.0/61.0	8.1	8.3	9.4	
62.0			9.7	7.4		11.5/60.7	9.6	7.2		9.6	9.2	6.8	8.0	8.2	9.0	6.4/62.9
64.0			9.2	7.0			9.1	6.8		9.5/63.7	8.9	6.5	7.9/62.1	8.1	8.6	6.3
66.0			9.0/64.9	6.6			8.7	6.5			8.5	6.2		8.0	8.2	5.9
68.0				6.3			8.3/67.8	6.2			8.1	5.9		7.9/66.6	7.9	5.7
70.0				6.0				5.9			7.7	5.6			7.5	5.4
72.0				5.7				5.6			7.6/70.8	5.4			7.2	5.1
74.0				5.6/73.3				5.3				5.1			6.9/73.7	4.9
76.0								5.0				4.8				4.6
78.0								5.0/76.3				4.6				4.4
80.0												4.3/79.2				4.2
82.0																3.9
84.0																3.9/82.1

■ w/54.85m Tower

Jib Length (m) Tower Angle (°) Working radius(m)	24.4				27.4				30.5				33.5				36.6			
	88	83	75	65	88	83	75	65	88	83	75	65	88	83	75	65	88	83	75	65
10.0	56.3/11.5																			
12.0	54.9				51.6/12.4				45.7/13.3											
14.0	50.6				48.5				44.6				42.2/14.2				34.9/15.1			
16.0	47.1				45.2				41.6				39.8				34.5			
18.0	44.2	46.2/18.3			42.5	42.8/19.4			39.2				37.5				33.6			
20.0	41.9	43.5			40.2	41.8			37.1	37.8/20.6			35.5	35.0/21.7			32.4			
22.0	40.0	40.4			38.4	39.3			35.4	36.3			33.8	34.7			30.9	32.6/22.8		
24.0	38.4	37.1			36.8	36.8			33.9	34.3			31.9	32.9			29.0	31.4		
26.0	35.0	34.4			35.5	34.1			32.7	32.7			29.5	30.6			27.3	29.9		
28.0	32.3/27.6	32.0	26.9/28.8		32.2	31.7			31.7	31.1			27.5	28.0			25.5	27.9		
30.0		29.9	25.7		29.4	29.6	25.3/30.3		29.8	29.1	23.5/31.8		25.6	25.8			23.9	25.7		
32.0		28.2	24.1		28.8/30.5	27.8	23.8		27.4	27.2	23.3		23.9	23.9	21.9/33.4		22.5	23.8		
34.0		27.9/32.4	22.6			26.2	22.4		25.8/33.5	25.6	21.9		22.4	22.2	21.4		21.3	22.1	20.5/34.9	
36.0			21.3			25.4/35.3	21.1			24.2	20.6		20.2	20.8	20.2		19.9	20.7	19.8	
38.0			20.1				19.9			23.0	19.4		20.1/36.4	19.8	19.0		18.7	19.5	18.7	
40.0			19.1/39.9	14.9/41.2			18.9			22.9/38.2	18.4			18.9	18.0		18.7/39.4	18.4	17.6	
42.0				14.5			17.9	13.9/43.2			17.5			18.6/41.2	17.0			17.8	16.7	
44.0				13.6			17.4/42.8	13.6			16.6	12.9/45.1			16.2			17.5	15.9	
46.0				12.8				12.8			15.8/45.7	12.5			15.4	11.8/47.1		17.4/44.1	15.1	
48.0				12.1				12.1				11.8			14.6	11.5			14.4	11.0/49.0
50.0				11.9/48.8				11.4				11.2			14.3/48.7	10.9			13.7	10.7
52.0								10.9/51.8				10.6				10.3			13.1/51.6	10.2
54.0												10.0				9.8				9.6
56.0												9.9/54.7				9.3				9.1
58.0																8.9/57.6				8.6
60.0																				8.2
62.0																				8.1/60.6

■ w/54.85m Tower

Jib Length (m)	39.6				42.7				45.7				48.8				51.8			
Tower Angle (°)	88	83	75	65	88	83	75	65	88	83	75	65	88	83	75	65	88	83	75	65
Working radius(m)																				
16.0	30.3				28.1/16.9				25.8/17.7											
18.0	30.1				28.0				25.8				23.3/18.4				22.4/19.3			
20.0	29.9				27.7				25.5				23.2				22.1			
22.0	29.7				27.5				25.2				22.9				20.9			
24.0	28.5	29.7			26.7	27.5/25.1			24.9				22.3				20.4			
26.0	27.2	28.3			25.9	26.9			24.5	25.2/26.3			21.8	22.3/27.1			20.0			
28.0	25.2	27.0			24.4	25.7			23.5	24.2			21.4	22.0			19.7	20.2/28.3		
30.0	23.6	25.7			23.1	24.7			22.6	23.3			21.0	21.4			19.2	19.7		
32.0	22.2	23.8			21.8	23.4			21.5	22.4			19.9	20.9			18.4	18.7		
34.0	20.9	22.1			20.6	21.8			20.4	21.6			18.9	19.7			17.7	17.8		
36.0	19.8	20.7	19.6/36.4		19.4	20.4	18.3/37.9		19.3	20.2			17.9	18.6			17.0	16.9		
38.0	18.9	19.2	18.6		18.3	19.0	18.2		18.3	18.9	17.0/39.5		17.0	17.5			16.4	16.1		
40.0	17.9	18.0	17.6		17.3	17.9	17.2		17.3	17.8	16.8		16.2	16.5	16.1/40.6		15.8	15.3		
42.0	17.2	17.2	16.7		16.6	16.9	16.3		16.5	16.7	15.9		15.4	15.6	15.6		15.2	14.7	15.0/42.1	
44.0	17.1/42.3	16.5	15.8		16.0	16.1	15.4		15.8	15.8	15.0		14.8	14.7	14.8		14.8	14.2	14.4	
46.0		16.0	15.0		15.9/45.3	15.6	14.6		15.2	14.9	14.3		14.2	13.9	14.0		14.3	13.7	13.6	
48.0		15.8/47.1	14.3			15.2	13.9		14.7	14.3	13.6		13.8	13.4	13.3		13.9	13.3	12.9	
50.0			13.7	10.3/51.0		15.0	13.3		14.7/48.2	13.9	12.9		13.5	13.1	12.7		13.6	13.1	12.3	
52.0			13.0	10.1			12.7	9.5/53.0		13.7	12.3		13.5/50.4	12.9	12.1		13.3	12.8	11.7	
54.0			12.4	9.6			12.1	9.3		13.6/53.0	11.8	8.8/54.9		12.8	11.5		13.1/53.4	12.7	11.1	
56.0			12.1/54.6	9.1			11.5	8.8			11.3	8.5		12.7/55.2	11.0	8.1/56.4		12.6	10.6	
58.0				8.7			11.1/57.5	8.4			10.7	8.1			10.5	7.8		12.4	10.2	7.4/58.3
60.0				8.2				8.0			10.2	7.7			10.1	7.4		11.8/58.2	9.7	7.1
62.0				7.8				7.6			10.1/60.5	7.3			9.6	7.1			9.3	6.7
64.0				7.5/63.5				7.2				6.9			9.4/62.7	6.7			8.9	6.4
66.0								6.8				6.6				6.4			8.6/65.7	6.1
68.0								6.8/66.5				6.3				6.1				5.8
70.0												6.0/69.4				5.8				5.5
72.0																5.6/71.7				5.3
74.0																				5.0
76.0																				4.9/74.6

■ w/54.85m Tower

Jib Length (m)	54.9				57.9				61.0			
Tower Angle (°)	88	83	75	65	88	83	75	65	88	83	75	65
Working radius(m)												
20.0	20.4/20.2				17.9/21.1							
22.0	19.6				17.6				15.7			
24.0	18.7				17.0				15.3			
26.0	18.3				16.6				14.9			
28.0	18.0	18.4/29.4			16.3				14.5			
30.0	17.7	18.1			15.9	16.5/30.5			14.1	14.4/31.7		
32.0	16.9	17.3			15.4	16.1			13.7	14.3		
34.0	16.1	16.6			14.6	15.4			13.2	13.9		
36.0	15.3	15.8			13.9	14.5			12.7	13.2		
38.0	14.6	14.9			13.3	13.8			12.3	12.5		
40.0	14.1	14.2			12.9	13.1			11.8	11.9		
42.0	13.6	13.8	14.1/43.7		12.6	12.6			11.2	11.5		
44.0	13.3	13.3	14.1		12.1	12.2	13.3/45.2		10.7	11.2		
46.0	13.0	12.9	13.4		11.6	11.9	13.0		10.2	10.9	12.4/46.7	
48.0	12.7	12.5	12.7		11.2	11.5	12.4		9.8	10.4	12.1	
50.0	12.5	12.3	12.1		10.8	11.3	11.7		9.4	9.9	11.5	
52.0	12.4	12.1	11.5		10.4	10.9	11.2		9.0	9.5	10.9	
54.0	12.3	11.9	10.9		10.1	10.6	10.6		8.7	9.2	10.4	
56.0	12.2	11.8	10.4		9.9	10.3	10.1		8.5	8.9	9.9	
58.0	12.1/56.3	11.7	10.0		9.7	10.0	9.6		8.3	8.6	9.4	
60.0		11.5	9.5	6.8/60.3	9.5/59.3	9.8	9.2		8.1	8.4	9.0	
62.0		11.4/61.1	9.1	6.5		9.7	8.8	6.2/62.3	8.0	8.2	8.6	
64.0			8.7	6.2		9.6	8.4	5.9	7.9/62.2	8.1	8.2	5.6/64.2
66.0			8.4	5.9			8.1	5.6		8.0	7.8	5.4
68.0			8.0	5.6			7.7	5.3		8.0/67.0	7.5	5.1
70.0			7.9/68.6	5.4			7.4	5.0			7.2	4.8
72.0				5.1			7.2/71.5	4.8			6.9	4.6
74.0				4.9				4.6			6.6	4.3
76.0				4.6				4.3			6.5/74.5	4.1
78.0				4.6/77.5				4.1				3.9
80.0								4.0				3.7
82.0								3.9/80.5				3.5
84.0												3.4/83.4

■ w/57.90m Tower

Jib Length (m)	27.4				30.5				33.5				36.6				39.6			
Tower Angle (°)	88	83	75	65	88	83	75	65	88	83	75	65	88	83	75	65	88	83	75	65
Working radius(m)																				
12.0	47.8/12.5				42.2/13.4															
14.0	44.9				41.3				38.7/14.3				35.0/15.2							
16.0	41.8				38.6				36.6				34.3				27.5/16.1			
18.0	39.2	39.0/19.8			36.2				34.5				32.5				27.0			
20.0	37.0	38.8			34.3	34.8/20.9			32.7				31.1				27.0			
22.0	35.2	36.4			32.6	33.6			31.1	31.9/22.1			29.8	29.8/23.2			27.0			
24.0	33.7	34.3			31.2	31.7			29.8	30.3			27.5	29.0			25.5	27.5/24.3		
26.0	32.5	32.6			30.0	30.1			28.7	28.8			25.5	27.7			23.6	26.4		
28.0	31.5	31.0			29.0	28.8			27.7	27.5			23.7	25.9			22.0	25.2		
30.0	29.5	29.0	23.8/31.1		28.2	27.6			26.9	26.4			22.1	23.9			20.5	23.9		
32.0	28.8/30.6	27.2	23.0		27.5	26.6	22.1/32.6		26.3	25.5			20.7	22.3			19.2	22.3		
34.0		25.6	21.6		25.8/33.6	25.1	21.1		25.8	24.7	20.9/34.2		19.4	20.8	19.6/35.7		18.4	20.8		
36.0		24.5/35.7	20.3			23.7	19.8		23.9	23.5	19.7		18.2	19.4	19.4		17.7	19.4	18.4/37.2	
38.0			19.2			22.5	18.7		23.5/36.5	22.3	18.6		17.3	18.2	18.3		17.1	18.2	17.9	
40.0			18.1			22.2/38.6	17.7			21.1	17.6		17.1/39.5	17.1	17.3		16.5	17.1	16.9	
42.0			17.2				16.8				20.4/41.6	16.7		16.4	16.4		15.9	16.3	16.0	
44.0			16.6/43.6	12.7/44.4			16.0					15.9		16.0	15.6		15.8/42.4	15.5	15.2	
46.0				12.1			15.3	11.7/46.4				15.1			15.9/44.5	14.8		15.1	14.4	
48.0				11.5			15.1/46.5	11.1				14.4	10.9/48.4		14.1			15.0/47.5	13.7	
50.0				10.9				10.6				13.9/49.5	10.5			13.5	10.2/50.3		13.1	
52.0				10.3				10.0					10.0			12.8	9.7		12.5	9.3/52.3
54.0				10.0/53.0				9.5					9.5			12.7/52.4	9.3		12.0	8.9
56.0								9.0					9.0				8.8		11.6/55.4	8.5
58.0													8.5				8.4			8.1
60.0													8.3/58.9				7.9			7.7
62.0																	7.6/61.9			7.3
64.0																				7.0
66.0																				6.8/64.8

■ w/57.90m Tower

Jib Length (m)	42.7				45.7				48.8				51.8				54.9			
Tower Angle (°)	88	83	75	65	88	83	75	65	88	83	75	65	88	83	75	65	88	83	75	65
Working radius(m)																				
16.0	26.2/17.0				24.9/17.8															
18.0	26.2				24.9				22.6/18.5				21.3/19.4							
20.0	26.1				24.6				22.5				21.0				19.5/20.3			
22.0	25.9				24.3				22.2				20.0				18.7			
24.0	24.7	25.5/25.5			24.0				21.9				19.7				18.1			
26.0	23.5	25.2			23.4	23.6/26.6			21.5	21.7/27.5			19.4				17.8			
28.0	21.9	24.0			21.9	22.7			20.5	21.5			19.1	19.6/28.6			17.6	17.9/29.8		
30.0	20.4	23.0			20.4	21.8			19.5	20.6			18.8	19.6			17.3	17.8		
32.0	19.1	22.0			19.1	20.9			18.6	19.8			18.1	18.6			16.7	17.1		
34.0	18.0	20.5			17.9	20.1			17.7	18.9			17.5	17.7			16.1	16.5		
36.0	17.2	19.2			16.9	18.9			16.7	17.9			16.6	16.8			15.3	15.7		
38.0	16.4	18.0	17.2/38.7		15.9	17.8			15.8	16.9			15.7	16.0			14.4	14.8		
40.0	15.8	16.9	16.5		15.1	16.8	16.0/40.3		14.8	16.0	15.1/41.4		15.0	15.1			13.7	14.1		
42.0	15.1	15.9	15.6		14.4	15.8	15.2		14.0	15.0	14.9		14.2	14.3	14.1/42.9		13.2	13.4		
44.0	14.7	15.1	14.8		13.9	14.9	14.4		13.4	14.2	14.1		13.6	13.6	13.7		12.7	12.7	13.3/44.5	
46.0	14.6/45.4	14.5	14.0		13.7	14.1	13.7		12.9	13.4	13.4		13.1	13.1	13.0		12.4	12.1	12.8	
48.0		14.1	13.4		13.5	13.4	13.0		12.6	12.7	12.7		12.9	12.6	12.4		12.1	11.7	12.2	
50.0		13.9	12.7		13.4/48.3	13.0	12.4		12.5	12.2	12.1		12.6	12.2	11.7		11.8	11.4	11.5	
52.0		13.8/50.4	12.1			12.7	11.8		12.4/50.5	11.9	11.5		12.3	12.0	11.2		11.6	11.2	11.0	
54.0			11.6	8.6/54.2		12.6/53.3	11.3			11.8	11.0		12.2/53.5	11.8	10.6		11.5	11.0	10.4	
56.0			11.1	8.1			10.8	7.8/56.2		11.7/55.6	10.5	7.2/57.7		11.7	10.1		11.4	10.8	10.0	
58.0			10.6	7.7			10.3	7.4			10.0	7.1		11.6	9.7	6.5/59.6	11.3/56.4	10.8	9.5	
60.0			10.6/58.3	7.4			9.9	7.0			9.6	6.8		11.5/58.5	9.3	6.4		10.7	9.1	5.9/61.6
62.0				7.0			9.6/61.3	6.7			9.2	6.4			8.9	6.1		10.6/61.5	8.7	5.9
64.0				6.7				6.4			9.0/63.5	6.1			8.5	5.8			8.3	5.6
66.0				6.4				6.1				5.8			8.2	5.5			8.0	5.3
68.0				6.1/67.8				5.8				5.6			8.1/66.4	5.2			7.6	5.1
70.0								5.5				5.3				5.0			7.4/69.4	4.8
72.0									5.4/70.7			5.1								4.6
74.0													5.0/72.9							4.3
76.0																				4.1
78.0																				3.9
80.0																				3.9/78.8

■ w/57.90m Tower

Jib Length (m)	57.9				61.0			
Tower Angle (°)	88	83	75	65	88	83	75	65
Working radius(m)								
20.0	17.7/21.2							
22.0	17.4				15.6/22.1			
24.0	16.9				15.0			
26.0	16.4				14.7			
28.0	16.1				14.3			
30.0	15.7	16.3/30.9			13.9			
32.0	15.3	15.9			13.6	14.2/32.1		
34.0	14.6	15.4			13.2	13.8		
36.0	13.9	14.5			12.6	13.2		
38.0	13.3	13.8			12.0	12.5		
40.0	12.7	13.2			11.5	11.9		
42.0	12.1	12.6			11.0	11.4		
44.0	11.6	12.0			10.7	10.9		
46.0	11.2	11.5	12.4		10.2	10.4	11.6/47.5	
48.0	11.0	11.0	11.8		9.8	10.0	11.5	
50.0	10.8	10.7	11.2		9.4	9.7	10.9	
52.0	10.4	10.4	10.6		9.0	9.5	10.4	
54.0	10.1	10.1	10.1		8.7	9.2	9.9	
56.0	9.9	10.0	9.6		8.5	8.9	9.4	
58.0	9.7	9.8	9.2		8.3	8.6	8.9	
60.0	9.6/59.4	9.8	8.7		8.1	8.4	8.5	
62.0		9.7	8.3	5.3/63.6	8.0	8.2	8.1	
64.0		9.6	8.0	5.3	8.0/62.3	8.1	7.7	4.7/65.5
66.0		9.6/64.4	7.6	5.0		7.9	7.4	4.7
68.0			7.3	4.7		7.8/67.4	7.1	4.5
70.0			7.0	4.5			6.8	4.2
72.0			6.7	4.2			6.5	4.0
74.0			6.7/72.3	4.0			6.2	3.8
76.0				3.8			6.1/75.3	3.6
78.0				3.6				3.4
80.0				3.4				3.2
82.0				3.3/81.8				3.0
84.0								2.9
86.0								2.8/84.7

■ w/60.95m Tower

Jib Length (m)	30.5				33.5				36.6				39.6				42.7			
Tower Angle (°)	88	83	75	65	88	83	75	65	88	83	75	65	88	83	75	65	88	83	75	65
Working radius(m)																				
12.0	39.3/13.5																			
14.0	38.7				37.1/14.4			35.5/15.3												
16.0	35.8				35.1			34.7					29.7/16.2				25.8/17.1			
18.0	33.4				32.9			32.5					29.7				25.8			
20.0	31.4	32.1/21.3			31.0			30.7					28.6				25.0			
22.0	29.6	31.4			29.4	30.3/22.4		29.0	28.9/23.6				26.1				23.8			
24.0	28.1	29.4			28.0	28.8		27.6	28.6				24.2	24.0/24.7			22.3	23.0/25.9		
26.0	26.7	27.7			26.8	27.3		26.4	27.0				22.4	24.0			20.7	22.9		
28.0	25.6	26.3			25.7	25.9		25.3	25.6				20.7	22.2			19.1	22.1		
30.0	24.5	25.0			24.9	24.8		24.4	24.5				19.3	20.6			17.9	20.5		
32.0	23.7	24.0	21.0/33.4		24.1	23.8		23.6	23.4				18.1	19.2			16.9	19.1		
34.0	23.3/33.7	23.1	20.6		23.5	22.9	19.6/35.0		22.9	22.5			17.2	17.9			16.1	17.8		
36.0		22.4	19.4		23.1	22.2	19.0		22.4	21.7	18.3/36.5		16.4	16.8			15.3	16.7		
38.0		21.6	18.3		23.0/36.6	21.6	17.9		21.9	21.1	17.6		15.6	15.7	17.1		14.8	15.6	16.1/39.5	
40.0		21.1/39.0	17.3		20.7	16.9		21.5/39.6	20.3	16.6			15.0	14.9	16.2		14.1	14.6	15.8	
42.0			16.4			19.8/41.9	16.0		19.3	15.7			14.6	14.4	15.3		13.8	13.9	14.9	
44.0			15.6				15.2			18.4	14.9		14.5/42.5	13.9	14.5		13.5	13.3	14.2	
46.0			14.1	9.7/47.7			14.5			18.1/44.9	14.2			13.6	13.8		13.4/45.5	12.9	13.4	
48.0			13.7/47.3	9.7			13.3	9.2/49.7			13.5			13.4/47.8	13.1			12.6	12.8	
50.0				9.2			12.8	9.1			12.4	8.5/51.6			12.5			12.3	12.2	
52.0				8.8			12.7/50.3	8.7			11.9	8.4			11.7	8.0/53.6		12.2/50.8	11.6	
54.0				8.4				8.3			11.6/53.2	8.0			11.2	7.9			10.8	7.3/55.5
56.0				8.0				7.9				7.6			10.8	7.5			10.4	7.1
58.0				7.7/57.3				7.5				7.2			10.7/56.2	7.1			10.0	6.8
60.0								7.2				6.9				6.8			9.7/59.1	6.4
62.0												6.6				6.5				6.1
64.0												6.4/63.2				6.2				5.8
66.0																6.0				5.6
68.0																5.9/66.1				5.3
70.0																				5.1/69.0

■ w/60.95m Tower

Jib Length (m) Tower Angle (°) Working radius(m)	45.7				48.8				51.8				54.9				57.9			
	88	83	75	65	88	83	75	65	88	83	75	65	88	83	75	65	88	83	75	65
18.0	24.0				21.9/18.6				19.7/19.5											
20.0	23.7				21.7				19.7				18.0/20.4				16.3/21.3			
22.0	23.4				21.4				19.4				17.8				16.2			
24.0	22.2				20.7				19.1				17.5				16.0			
26.0	20.6	22.0/27.0			19.6	20.5/27.9			18.8				17.3				15.8			
28.0	19.1	22.0			18.4	20.4			17.8	18.9/29.0			16.7				15.6			
30.0	17.8	20.5			17.2	19.6			16.7	18.9			16.0	17.7/30.1			15.4	16.6/31.3		
32.0	16.7	19.1			16.2	18.4			15.7	17.8			15.0	16.9			14.5	15.5		
34.0	15.7	17.8			15.1	17.2			14.7	16.7			14.2	16.2			13.7	15.2		
36.0	14.9	16.7			14.2	16.2			13.9	15.7			13.4	15.2			13.0	14.8		
38.0	14.2	15.6			13.5	15.1			13.1	14.7			12.7	14.3			12.4	14.0		
40.0	13.7	14.6	15.0/41.0		13.1	14.2			12.4	13.9			12.1	13.6			11.8	13.3		
42.0	13.3	13.8	14.6		12.7	13.4	14.1/42.2		12.0	13.1	13.1/43.7		11.5	12.9			11.2	12.7		
44.0	13.0	13.1	13.8		12.4	12.7	13.5		11.7	12.4	13.1		11.1	12.3	12.4/45.2		10.7	12.2		
46.0	12.8	12.6	13.1		12.1	12.1	12.8		11.4	11.7	12.4		10.8	11.7	12.2		10.2	11.7	11.5/46.8	
48.0	12.6	12.2	12.4		11.9	11.7	12.1		11.1	11.1	11.8		10.5	11.1	11.6		9.8	11.1	11.2	
50.0	12.5/48.4	12.0	11.8		11.7	11.3	11.5		10.9	10.8	11.2		10.3	10.6	11.0		9.6	10.6	10.6	
52.0		11.9	11.2		11.6/50.7	11.1	11.0		10.8	10.6	10.6		10.1	10.2	10.4		9.4	10.2	10.1	
54.0		11.8/53.7	10.7			10.9	10.5		10.7/53.6	10.3	10.1		10.0	10.1	9.9		9.3	9.8	9.6	
56.0			10.2	6.7/57.5		10.8	10.0			10.2	9.6		9.9	9.9	9.4		9.2	9.5	9.1	
58.0			9.8	6.7			9.5	6.3/59.0		9.9	9.2		9.9/56.5	9.8	9.0		9.1	9.3	8.7	
60.0			9.4	6.4			9.1	6.1		9.8/58.9	8.8	5.6/60.9		9.7	8.6		9.0/59.5	9.1	8.3	
62.0			9.1	6.0			8.7	5.8			8.4	5.4		9.6/61.8	8.2	5.1/62.9		9.0	7.9	
64.0				5.7			8.4	5.5			8.0	5.2			7.8	5.0		8.8	7.5	4.5/64.8
66.0				5.5			8.4/64.3	5.2			7.7	4.9			7.5	4.7		8.8/64.8	7.2	4.4
68.0				5.2				5.0			7.6/67.2	4.6			7.2	4.4			6.9	4.1
70.0				5.0				4.7				4.4			6.9	4.2			6.6	3.9
72.0				4.7				4.5				4.2			6.9/70.2	4.0			6.3	3.7
74.0								4.3				3.9				3.8			6.2/73.1	3.5
76.0								4.2/74.2				3.7				3.6				3.3
78.0												3.6/77.2				3.4				3.1
80.0																3.2				2.9
82.0																3.2/80.1				2.7
84.0																				2.7/83.1

■ w/60.95m Tower

Jib Length (m) Tower Angle (°) Working radius(m)	61.0			
	88	83	75	65
22.0	15.3/22.2			
24.0	14.9			
26.0	14.4			
28.0	13.9			
30.0	13.5			
32.0	13.2	13.9/32.4		
34.0	12.9	13.6		
36.0	12.6	13.2		
38.0	12.4	12.9		
40.0	11.8	12.6		
42.0	11.2	12.3		
44.0	10.7	12.0		
46.0	10.2	11.6		
48.0	9.8	11.1	10.8/48.3	
50.0	9.4	10.6	10.4	
52.0	9.0	10.1	9.8	
54.0	8.7	9.7	9.3	
56.0	8.5	9.3	8.9	
58.0	8.2	9.0	8.4	
60.0	8.2	8.7	8.0	
62.0	8.0	8.4	7.6	
64.0	8.0/62.4	8.3	7.3	
66.0		8.2	6.9	4.0/66.8
68.0		8.0/67.7	6.6	3.9
70.0			6.3	3.6
72.0			6.1	3.4
74.0			5.8	3.2
76.0			5.6	3.0
78.0			5.6/76.1	2.8
80.0				2.7
82.0				2.5
84.0				2.3
86.0				2.2

Notes — Luffing jib crane capacities

1. Capacities included in these charts are the maximum allowable, and are based on machine standing level on firm supporting surface under ideal job conditions.
2. Capacities are in metric tons, and are rated in accordance with European EN13000 Standards in terms of machine stability and structural strength limitations; the figures surrounded by bold lines are based on factors other than those which would cause a tipping condition.
3. Capacities are based on freely suspended loads and make no allowance for such factors as the effect of wind, sudden stopping of loads, supporting surface conditions, and operating speeds. Operator must reduce load ratings to take such conditions into account. Deduction from rated capacities must be made for weight of hook block, weighted ball/hook, sling, spreader bar, or other suspended gear.
Hook block weight is as follows:
80t.....1.4ton 35t0.9ton 13.5t0.6ton
4. All capacities are rated for 360° swing.
5. Least stable rated condition is over the side.
6. An 102.8ton counterweight and 18.0ton carbody weight are required for all capacities on these charts.
7. Attachment must be erected and lowered over the ends of the crawler mounting.
8. Working radii shown above are at loading condition.
9. The machine can be steplessly operated at tower angle between 88 and 65 degrees safely; luffing jib crane capacities available under any tower angle are automatically set up by the Load Moment Indicator, a computerized automatic over-load preventing system.
10. The machine shall be operated in accordance with manufacturer's standard tower boom and jib combination shown in page 26 here.
11. A simultaneous lift under luffing jib hook and tower boom top crane hook is not allowed.

Luffing Jib Working Ranges

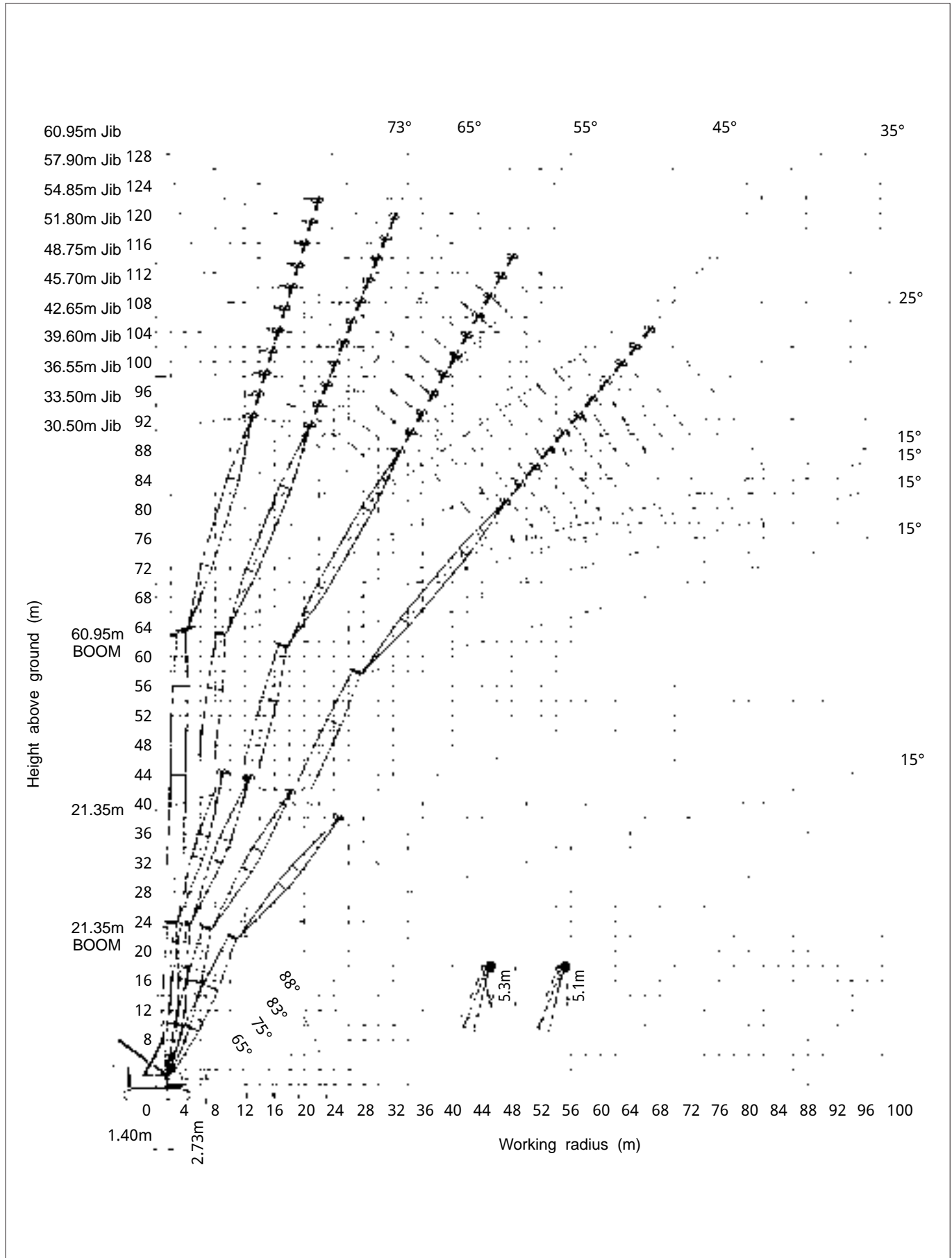

Tower Boom & Jib Combination Table

■ Tower Boom Configuration

Boom length (m)	Tower boom configuration
21.35m	
24.40m	★
27.45m	
30.50m	★
33.50m	
36.55m	★
39.60m	
42.65m	★
45.70m	
48.75m	★
51.80m	
54.85m	★
57.90m	
60.95m	★

Note:

The meaning of figures and symbols shown above is as follows:

- : 7.62m heavy-duty bottom section
- : 7.30m heavy-duty top section
plus 0.32m head section
- : 12.20m HD tower boom extension
- : 12.20m ultra HD tower boom extension
- : 6.10m ultra HD tower boom extension
- : 3.05m ultra HD tower boom extension

Remarks:

A star mark (★) indicates manufacturer's recommended boom configuration in a consideration that it is able to set boom length in the pitch of 3.05 meters from its maximum length; other boom configuration with no star mark (★) is not able to do such an arrangement of boom length.

■ Jib Configuration

Jib length (m)	Jib boom configuration
21.35m	★
24.40m	
27.45m	★
30.50m	
33.50m	★
36.55m	
39.60m	★
42.65m	
45.70m	★
48.75m	
51.80m	★
54.85m	
57.90m	★
60.95m	★

Note:

The meaning of figures and symbols shown above is as follows:

- : 9.15m jib bottom section
- : 9.15m jib top section
- : 12.20m HD jib extension
- : 9.15m jib extension
- : 6.10m jib extension
- : 3.05m jib extension
- ★ : Midpoint suspension cable installing position; it is required to install it when jib length is 51.80m and over.

■ Combination Table

Jib length (m) Tower length (m)	21.35	24.40	27.45	30.50	33.50	36.55	39.60	42.65	45.70	48.75	51.80	54.85	57.90	60.95
21.35	⊙	⊙	⊙	⊙	⊙	⊙	⊙	⊙	⊙	⊙	⊙	⊙	⊙	⊙
24.40	⊙	⊙	⊙	⊙	⊙	⊙	⊙	⊙	⊙	⊙	⊙	⊙	⊙	⊙
27.45	⊙	⊙	⊙	⊙	⊙	⊙	⊙	⊙	⊙	⊙	⊙	⊙	⊙	⊙
30.50	⊙	⊙	⊙	⊙	⊙	⊙	⊙	⊙	⊙	⊙	⊙	⊙	⊙	⊙
33.50	⊙	⊙	⊙	⊙	⊙	⊙	⊙	⊙	⊙	⊙	⊙	⊙	⊙	⊙
36.55	⊙	⊙	⊙	⊙	⊙	⊙	⊙	⊙	⊙	⊙	⊙	⊙	⊙	⊙
39.60	⊙	⊙	⊙	⊙	⊙	⊙	⊙	⊙	⊙	⊙	⊙	⊙	⊙	⊙
42.65	⊙	⊙	⊙	⊙	⊙	⊙	⊙	⊙	⊙	⊙	⊙	⊙	⊙	⊙
45.70	⊙	⊙	⊙	⊙	⊙	⊙	⊙	⊙	⊙	⊙	⊙	⊙	⊙	⊙
48.75	⊙	⊙	⊙	⊙	⊙	⊙	⊙	⊙	⊙	⊙	⊙	⊙	⊙	⊙
51.80	⊙	⊙	⊙	⊙	⊙	⊙	⊙	⊙	⊙	⊙	⊙	⊙	⊙	⊙
54.85	x	⊙	⊙	⊙	⊙	⊙	⊙	⊙	⊙	⊙	⊙	⊙	⊙	⊙
57.90	x	x	⊙	⊙	⊙	⊙	⊙	⊙	⊙	⊙	⊙	⊙	⊙	⊙
60.95	x	x	x	⊙	⊙	⊙	⊙	⊙	⊙	⊙	⊙	⊙	⊙	⊙

Notes:

The meaning of symbols shown in the above table is as follows;

1. Symbol of "⊙" : Possible to luff tower between 88° thru 65°;
2. Symbol of "x" : Impossible to make tower boom and jib combination.

Tower Boom Top Crane Capacities - 80 metric tons

■ w/21.35m Tower

Tower Angle (°) Working radius(m)	21.3	24.4	27.4	30.5	33.5	36.6	39.6	42.7	45.7	48.8	51.8	54.9	57.9	61.0
5.5	80.0	80.0	80.0	80.0	80.0	80.0	80.0	80.0	80.0	80.0	80.0	80.0	80.0	80.0
6.0	80.0	80.0	80.0	80.0	80.0	80.0	80.0	80.0	80.0	80.0	80.0	80.0	80.0	80.0
6.5	80.0	80.0	80.0	80.0	80.0	80.0	80.0	80.0	80.0	80.0	80.0	80.0	80.0	80.0
7.0	80.0	80.0	80.0	80.0	80.0	80.0	80.0	80.0	80.0	80.0	80.0	80.0	80.0	80.0
7.5	80.0	80.0	80.0	80.0	80.0	80.0	80.0	80.0	80.0	80.0	80.0	80.0	80.0	80.0
8.0	80.0	80.0	80.0	80.0	80.0	80.0	80.0	80.0	80.0	80.0	80.0	80.0	80.0	80.0
9.0	80.0	80.0	80.0	80.0	80.0	80.0	80.0	80.0	80.0	80.0	80.0	80.0	80.0	80.0
10.0	80.0	80.0	80.0	80.0	80.0	80.0	80.0	80.0	80.0	80.0	80.0	80.0	80.0	80.0
11.0	80.0/10.9	80.0/10.9	80.0/10.9	80.0/10.9	80.0/10.9	80.0/10.9	80.0/10.9	80.0/10.9	80.0/10.9	80.0/10.9	80.0/10.9	80.0/10.9	80.0/10.9	80.0/10.9

■ w/24.40m Tower

Tower Angle (°) Working radius(m)	21.3	24.4	27.4	30.5	33.5	36.6	39.6	42.7	45.7	48.8	51.8	54.9	57.9	61.0
5.5	80.0/5.9	80.0/5.9	80.0/5.9	80.0/5.9	80.0/5.9	80.0/5.9	80.0/5.9	80.0/5.9	80.0/5.9	80.0/5.9	80.0/5.9	80.0/5.9	80.0/5.9	80.0/5.9
6.0	80.0	80.0	80.0	80.0	80.0	80.0	80.0	80.0	80.0	80.0	80.0	80.0	80.0	80.0
6.5	80.0	80.0	80.0	80.0	80.0	80.0	80.0	80.0	80.0	80.0	80.0	80.0	80.0	80.0
7.0	80.0	80.0	80.0	80.0	80.0	80.0	80.0	80.0	80.0	80.0	80.0	80.0	80.0	80.0
7.5	80.0	80.0	80.0	80.0	80.0	80.0	80.0	80.0	80.0	80.0	80.0	80.0	80.0	80.0
8.0	80.0	80.0	80.0	80.0	80.0	80.0	80.0	80.0	80.0	80.0	80.0	80.0	80.0	80.0
9.0	80.0	80.0	80.0	80.0	80.0	80.0	80.0	80.0	80.0	80.0	80.0	80.0	80.0	80.0
10.0	80.0	80.0	80.0	80.0	80.0	80.0	80.0	80.0	80.0	80.0	80.0	80.0	80.0	80.0
11.0	80.0	80.0	80.0	80.0	80.0	80.0	80.0	80.0	80.0	80.0	80.0	77.6	77.6	77.6
12.0	80.0	80.0	80.0	80.0	80.0	80.0	80.0	80.0	80.0	80.0	80.0	76.4	74.3	72.6
13.0	80.0/12.2	80.0/12.2	80.0/12.2	80.0/12.2	80.0/12.2	80.0/12.2	80.0/12.2	80.0/12.2	80.0/12.2	80.0/12.2	80.0/12.2	76.1/12.2	73.7/12.2	71.5/12.2

■ w/27.45m Tower

Tower Angle (°) Working radius(m)	21.3	24.4	27.4	30.5	33.5	36.6	39.6	42.7	45.7	48.8	51.8	54.9	57.9	61.0
6.0	80.0/6.4	80.0/6.4	80.0/6.4	80.0/6.4	80.0/6.4	80.0/6.4	80.0/6.4	80.0/6.4	80.0/6.4	80.0/6.4	80.0/6.4	80.0/6.4	80.0/6.4	80.0/6.4
6.5	80.0	80.0	80.0	80.0	80.0	80.0	80.0	80.0	80.0	80.0	80.0	80.0	80.0	80.0
7.0	80.0	80.0	80.0	80.0	80.0	80.0	80.0	80.0	80.0	80.0	80.0	80.0	80.0	80.0
7.5	80.0	80.0	80.0	80.0	80.0	80.0	80.0	80.0	80.0	80.0	80.0	80.0	80.0	80.0
8.0	80.0	80.0	80.0	80.0	80.0	80.0	80.0	80.0	80.0	80.0	80.0	80.0	80.0	80.0
9.0	80.0	80.0	80.0	80.0	80.0	80.0	80.0	80.0	80.0	80.0	80.0	80.0	80.0	80.0
10.0	80.0	80.0	80.0	80.0	80.0	80.0	80.0	80.0	80.0	80.0	80.0	80.0	80.0	80.0
11.0	80.0	80.0	80.0	80.0	80.0	80.0	80.0	80.0	80.0	80.0	77.6	77.6	77.6	77.6
12.0	80.0	80.0	77.6	77.6	77.6	77.6	77.6	77.6	77.6	77.6	76.7	75.4	73.5	71.8
13.0	80.0	80.0	77.5	76.5	75.6	74.3	73.5	71.8	71.1	69.7	67.9	66.6	64.7	63.1
14.0	80.0/13.5	80.0/13.5	77.4/13.5	75.9/13.5	74.6/13.5	72.7/13.5	71.4/13.5	68.9/13.5	67.8/13.5	65.7/13.5	63.4/13.5	62.1/13.5	60.4/13.5	58.7/13.5

■ w/30.50m Tower

Tower Angle (°) Working radius(m)	21.3	24.4	27.4	30.5	33.5	36.6	39.6	42.7	45.7	48.8	51.8	54.9	57.9	61.0
6.5	80.0/6.8	80.0/6.8	80.0/6.8	80.0/6.8	80.0/6.8	80.0/6.8	80.0/6.8	80.0/6.8	80.0/6.8	80.0/6.8	80.0/6.8	80.0/6.8	80.0/6.8	80.0/6.8
7.0	80.0	80.0	80.0	80.0	80.0	80.0	80.0	80.0	80.0	80.0	80.0	80.0	80.0	80.0
7.5	80.0	80.0	80.0	80.0	80.0	80.0	80.0	80.0	80.0	80.0	80.0	80.0	80.0	80.0
8.0	80.0	80.0	80.0	80.0	80.0	80.0	80.0	80.0	80.0	80.0	80.0	80.0	80.0	80.0
9.0	80.0	80.0	80.0	80.0	80.0	80.0	80.0	80.0	80.0	80.0	80.0	80.0	80.0	80.0
10.0	80.0	80.0	80.0	80.0	80.0	80.0	80.0	80.0	80.0	80.0	80.0	80.0	80.0	80.0
11.0	80.0	80.0	80.0	80.0	80.0	80.0	80.0	80.0	80.0	77.6	77.6	77.6	77.6	77.6
12.0	80.0	77.6	77.6	77.6	77.6	77.6	77.6	77.6	77.6	76.7	74.9	73.7	71.8	70.3
13.0	77.6	76.6	75.3	74.4	73.7	72.4	71.7	70.2	69.4	68.1	66.4	65.2	63.5	61.9
14.0	70.2	69.2	67.9	67.1	66.3	65.1	64.4	62.8	62.1	60.9	59.2	58.1	56.3	54.9
15.0	64.7/14.8	63.9/14.8	62.7/14.8	61.9/14.8	61.2/14.8	60.1/14.8	59.3/14.8	57.8/14.8	57.1/14.8	55.8/14.8	54.2/14.8	53.1/14.8	51.5/14.8	49.9/14.8

■ w/33.50m Tower

Tower Angle (°) Working radius(m)	21.3	24.4	27.4	30.5	33.5	36.6	39.6	42.7	45.7	48.8	51.8	54.9	57.9	61.0
7.0	80.0/7.3	80.0/7.3	80.0/7.3	80.0/7.3	80.0/7.3	80.0/7.3	80.0/7.3	80.0/7.3	80.0/7.3	80.0/7.3	80.0/7.3	80.0/7.3	80.0/7.3	80.0/7.3
7.5	80.0	80.0	80.0	80.0	80.0	80.0	80.0	80.0	80.0	80.0	80.0	80.0	80.0	80.0
8.0	80.0	80.0	80.0	80.0	80.0	80.0	80.0	80.0	80.0	80.0	80.0	80.0	80.0	80.0
9.0	80.0	80.0	80.0	80.0	80.0	80.0	80.0	80.0	80.0	80.0	80.0	80.0	80.0	80.0
10.0	80.0	80.0	80.0	80.0	80.0	80.0	80.0	80.0	80.0	80.0	80.0	80.0	80.0	80.0
11.0	80.0	80.0	80.0	80.0	80.0	80.0	80.0	77.6	77.6	77.6	77.6	77.6	77.6	77.6
12.0	77.6	77.6	77.6	77.6	77.6	77.6	77.6	77.1	76.4	75.1	73.4	72.2	70.5	69.0
13.0	75.8	74.8	73.6	72.7	72.0	70.9	70.2	68.7	68.0	66.9	65.1	64.1	62.4	60.9
14.0	68.6	67.7	66.4	65.6	64.9	63.8	63.1	61.6	61.1	59.8	58.2	57.1	55.4	54.1
15.0	62.4	61.4	60.3	59.5	58.8	57.7	57.0	55.6	54.9	53.8	52.2	51.2	49.6	48.2
16.0	57.1	56.1	54.9	54.2	53.5	52.4	51.7	50.4	49.7	48.5	47.0	46.0	44.5	43.1
18.0	56.5/16.1	55.5/16.1	54.4/16.1	53.6/16.1	52.9/16.1	51.8/16.1	51.2/16.1	49.8/16.1	49.1/16.1	48.0/16.1	46.4/16.1	45.4/16.1	43.9/16.1	42.5/16.1

■ w/36.55m Tower

Tower Angle (°) Working radius(m)	21.3	24.4	27.4	30.5	33.5	36.6	39.6	42.7	45.7	48.8	51.8	54.9	57.9	61.0
7.5	80.0/7.7	80.0/7.7	80.0/7.7	80.0/7.7	80.0/7.7	80.0/7.7	80.0/7.7	80.0/7.7	80.0/7.7	80.0/7.7	80.0/7.7	80.0/7.7	80.0/7.7	80.0/7.7
8.0	80.0	80.0	80.0	80.0	80.0	80.0	80.0	80.0	80.0	80.0	80.0	80.0	80.0	80.0
9.0	80.0	80.0	80.0	80.0	80.0	80.0	80.0	80.0	80.0	80.0	80.0	80.0	80.0	80.0
10.0	80.0	80.0	80.0	80.0	80.0	80.0	80.0	80.0	80.0	80.0	80.0	80.0	80.0	77.6
11.0	80.0	80.0	80.0	80.0	80.0	80.0	77.6	77.6	77.6	77.6	77.6	77.6	77.6	76.7
12.0	77.6	77.6	77.6	77.6	77.6	77.1	76.5	75.0	74.4	73.3	71.6	70.5	68.8	67.4
13.0	73.8	72.8	71.5	70.8	70.1	69.0	68.4	67.0	66.4	65.2	63.6	62.5	61.0	59.5
14.0	66.8	65.8	64.6	63.9	63.2	62.1	61.5	60.1	59.6	58.4	56.9	55.8	54.3	52.9
15.0	60.8	59.8	58.6	58.0	57.3	56.2	55.6	54.3	53.7	52.5	51.1	50.0	48.5	47.2
16.0	55.5	54.7	53.5	52.7	52.1	51.1	50.5	49.1	48.5	47.5	46.0	45.0	43.5	42.2
18.0	48.2/17.4	47.4/17.4	46.2/17.4	45.3/17.4	44.9/17.4	43.8/17.4	43.2/17.4	41.9/17.4	41.3/17.4	40.4/17.4	38.9/17.4	37.9/17.4	36.5/17.4	35.3/17.4

■ w/39.60m Tower

Tower Angle (°) Working radius(m)	21.3	24.4	27.4	30.5	33.5	36.6	39.6	42.7	45.7	48.8	51.8	54.9	57.9	61.0
8.0	80.0/8.2	80.0/8.2	80.0/8.2	80.0/8.2	80.0/8.2	80.0/8.2	80.0/8.2	80.0/8.2	80.0/8.2	80.0/8.2	80.0/8.2	80.0/8.2	80.0/8.2	80.0/8.2
9.0	80.0	80.0	80.0	80.0	80.0	80.0	80.0	80.0	80.0	80.0	80.0	80.0	80.0	80.0
10.0	80.0	80.0	80.0	80.0	80.0	80.0	80.0	80.0	80.0	80.0	80.0	80.0	77.6	77.6
11.0	80.0	80.0	80.0	80.0	77.6	77.6	77.6	77.6	77.6	77.6	77.6	77.6	76.4	74.9
12.0	77.6	77.6	77.6	77.6	77.1	76.0	75.5	74.2	72.8	71.6	70.0	68.9	67.4	66.0
13.0	72.4	71.5	71.0	69.8	69.2	68.1	67.7	66.4	65.0	63.9	62.3	61.4	59.7	58.4
14.0	65.7	64.7	64.2	63.0	62.5	61.4	61.1	59.7	58.4	57.3	55.8	54.8	53.3	51.9
15.0	59.8	58.9	58.3	57.3	56.7	55.7	55.2	54.0	52.7	51.6	50.1	49.1	47.7	46.4
16.0	54.8	53.9	53.3	52.1	51.7	50.7	50.2	48.9	47.7	46.6	45.2	44.3	42.8	41.6
18.0	46.3	45.4	44.9	43.8	43.3	42.3	41.9	40.7	39.4	38.4	37.0	36.1	34.8	33.5
20.0	43.3/18.7	42.4/18.7	41.9/18.7	40.8/18.7	40.3/18.7	39.3/18.7	38.8/18.7	37.8/18.7	36.5/18.7	35.5/18.7	34.1/18.7	33.2/18.7	31.9/18.7	30.6/18.7

■ w/42.65m Tower

Tower Angle (°) Working radius(m)	21.3	24.4	27.4	30.5	33.5	36.6	39.6	42.7	45.7	48.8	51.8	54.9	57.9	61.0
8.0	80.0/8.6	80.0/8.6	80.0/8.6	80.0/8.6	80.0/8.6	80.0/8.6	80.0/8.6	80.0/8.6	80.0/8.6	80.0/8.6	80.0/8.6	80.0/8.6	80.0/8.6	80.0/8.6
9.0	80.0	80.0	80.0	80.0	80.0	80.0	80.0	80.0	80.0	80.0	80.0	80.0	80.0	80.0
10.0	80.0	80.0	80.0	80.0	80.0	80.0	80.0	80.0	80.0	80.0	77.6	77.6	77.6	77.6
11.0	80.0	77.6	77.6	77.6	77.6	77.6	77.6	77.6	77.6	77.6	77.1	76.0	74.3	73.0
12.0	77.6	77.3	76.7	75.5	74.9	74.0	73.6	72.2	70.9	69.8	68.2	67.2	65.6	64.3
13.0	70.5	69.6	69.0	67.9	67.4	66.4	65.9	64.6	63.4	62.2	60.8	59.8	58.2	57.0
14.0	63.9	63.0	62.5	61.4	60.9	59.9	59.4	58.2	56.9	55.8	54.4	53.4	51.9	50.7
15.0	58.2	57.4	56.8	55.7	55.2	54.3	53.9	52.6	51.4	50.3	48.9	48.0	46.5	45.2
16.0	53.3	52.4	51.9	50.8	50.3	49.3	48.9	47.8	46.5	45.4	44.1	43.2	41.8	40.6
18.0	45.0	44.2	43.7	42.6	42.1	41.3	40.8	39.6	38.5	37.5	36.1	35.3	33.9	32.7
20.0	38.8/19.9	38.0/19.9	37.5/19.9	36.4/19.9	35.9/19.9	35.1/19.9	34.6/19.9	33.5/19.9	32.3/19.9	31.4/19.9	30.1/19.9	29.2/19.9	27.9/19.9	26.8/19.9

■ w/45.70m Tower

Tower Angle (°) Working radius(m)	21.3	24.4	27.4	30.5	33.5	36.6	39.6	42.7	45.7	48.8	51.8	54.9	57.9	61.0
9.0	80.0/9.1	80.0/9.1	80.0/9.1	80.0/9.1	80.0/9.1	80.0/9.1	80.0/9.1	80.0/9.1	80.0/9.1	77.6/9.1	77.6/9.1	77.6/9.1	77.6/9.1	77.6/9.1
10.0	80.0	80.0	80.0	80.0	80.0	80.0	80.0	80.0	80.0	77.6	77.6	77.6	77.6	77.6
11.0	77.6	77.6	77.6	77.6	77.6	77.6	77.6	77.6	77.6	76.7	75.1	74.1	72.5	71.1
12.0	76.2	75.3	74.7	73.6	73.1	72.1	71.7	70.5	69.2	68.0	66.6	65.6	64.1	62.8
13.0	68.7	67.9	67.4	66.2	65.7	64.7	64.5	63.2	61.9	60.9	59.4	58.4	57.0	55.7
14.0	62.3	61.4	61.0	59.9	59.4	58.5	58.2	56.9	55.6	54.6	53.2	52.2	50.9	49.6
15.0	56.8	56.0	55.5	54.4	54.0	53.0	52.6	51.5	50.2	49.2	47.9	46.9	45.5	44.4
16.0	52.0	51.2	50.7	49.6	49.1	48.3	47.9	46.7	45.5	44.5	43.2	42.2	40.9	39.7
18.0	44.0	43.1	42.6	41.7	41.2	40.3	39.9	38.8	37.6	36.7	35.4	34.5	33.2	32.1
20.0	37.5	36.7	36.3	35.3	34.8	34.0	33.6	32.4	31.4	30.4	29.1	28.4	27.0	25.9
22.0	33.5/21.2	32.8/21.2	32.5/21.2	31.4/21.2	30.9/21.2	30.2/21.2	29.8/21.2	28.7/21.2	27.6/21.2	26.6/21.2	25.4/21.2	24.7/21.2	23.2/21.2	22.3/21.2

■ w/48.75m Tower

Tower Angle (°) Working radius(m)	21.3	24.4	27.4	30.5	33.5	36.6	39.6	42.7	45.7	48.8	51.8	54.9	57.9	61.0
9.0	80.0/9.5	80.0/9.5	80.0/9.5	80.0/9.5	80.0/9.5	80.0/9.5	80.0/9.5	80.0/9.5	80.0/9.5	80.0/9.5	77.6/9.5	77.6/9.5	76.6/9.5	75.4/9.5
10.0	80.0	80.0	80.0	80.0	80.0	80.0	80.0	80.0	80.0	80.0	76.7	75.8	74.5	73.4
11.0	77.6	77.6	77.6	77.6	77.6	77.6	77.6	76.5	75.4	74.4	73.0	72.0	70.5	69.2
12.0	74.1	73.2	72.7	71.5	71.1	70.2	69.8	68.5	67.3	66.2	64.7	63.8	62.3	61.1
13.0	66.9	66.0	65.5	64.4	64.0	63.0	62.7	61.4	60.2	59.2	57.8	56.9	55.4	54.2
14.0	60.7	59.8	59.3	58.2	57.9	56.9	56.6	55.4	54.2	53.2	51.7	50.9	49.5	48.4
15.0	55.2	54.5	54.0	52.9	52.5	51.6	51.3	50.1	48.9	48.0	46.6	45.6	44.4	43.2
16.0	50.6	49.7	49.3	48.3	47.9	46.9	46.6	45.4	44.3	43.3	42.0	41.2	39.8	38.7
18.0	42.7	42.0	41.5	40.4	40.0	39.1	38.8	37.7	36.6	35.6	34.4	33.6	32.3	31.2
20.0	36.4	35.6	35.2	34.2	33.8	32.9	32.6	31.6	30.4	29.5	28.3	27.5	26.2	25.2
22.0	31.3	30.5	30.0	29.1	28.7	27.9	27.5	26.4	25.4	24.5	23.3	22.6	21.3	20.3
24.0	29.9/22.5	29.1/22.5	28.7/22.5	27.7/22.5	27.3/22.5	26.6/22.5	26.1/22.5	25.1/22.5	24.1/22.5	23.2/22.5	22.1/22.5	21.3/22.5	20.0/22.5	19.1/22.5

■ w/51.80m Tower

Tower Angle (°) Working radius(m)	21.3	24.4	27.4	30.5	33.5	36.6	39.6	42.7	45.7	48.8	51.8	54.9	57.9	61.0
10.0	78.1	77.3	77.0	76.0	75.7	74.9	74.8	73.8	72.7	71.8	70.6	69.7	68.4	67.3
11.0	75.0	74.2	73.9	72.9	72.6	71.8	71.7	70.6	69.6	68.6	67.4	66.5	65.3	64.1
12.0	69.9	69.1	68.8	67.8	67.6	66.8	66.7	65.6	64.6	63.7	62.5	61.6	60.4	59.2
13.0	65.6	64.7	64.4	63.2	62.8	61.9	61.6	60.5	59.2	58.2	56.9	55.9	54.6	53.4
14.0	59.6	58.7	58.3	57.3	56.9	56.0	55.7	54.6	53.3	52.3	51.0	50.1	48.7	47.6
15.0	54.4	53.6	53.1	52.0	51.7	50.8	50.5	49.4	48.3	47.3	45.9	45.1	43.8	42.6
16.0	49.8	48.9	48.5	47.5	47.1	46.3	45.9	44.9	43.7	42.8	41.5	40.7	39.3	38.3
18.0	42.0	41.3	40.9	39.9	39.5	38.7	38.4	37.3	36.2	35.3	34.1	33.2	32.0	30.9
20.0	35.9	35.2	34.8	33.8	33.4	32.5	32.3	31.2	30.1	29.2	28.1	27.3	26.0	25.1
22.0	30.9	30.1	29.7	28.8	28.4	27.6	27.3	26.2	25.2	24.3	23.1	22.5	21.2	20.2
24.0	27.0/23.8	26.3/23.8	25.8/23.8	25.0/23.8	24.6/23.8	23.8/23.8	23.5/23.8	22.5/23.8	21.5/23.8	20.6/23.8	19.4/23.8	18.8/23.8	17.6/23.8	16.6/23.8

■ w/54.85m Tower

Tower Angle (°) Working radius(m)	24.4	27.4	30.5	33.5	36.6	39.6	42.7	45.7	48.8	51.8	54.9	57.9	61.0
10.0	69.2/10.4	68.9/10.4	68.0/10.4	67.9/10.4	67.1/10.4	66.2/10.4	65.2/10.4	64.1/10.4	63.2/10.4	62.0/10.4	61.2/10.4	59.9/10.4	58.8/10.4
11.0	67.4	67.1	66.2	66.1	65.3	64.4	63.4	62.3	61.4	60.2	59.4	58.1	57.0
12.0	64.7	64.5	63.5	63.4	62.7	61.7	60.7	59.6	58.7	57.5	56.7	55.4	54.3
13.0	60.3	60.1	59.2	59.0	58.3	57.4	56.4	55.3	54.5	53.3	52.5	51.3	50.1
14.0	57.7	57.4	56.3	56.0	55.2	54.2	53.1	51.9	51.0	49.6	48.7	47.5	46.3
15.0	52.6	52.2	51.3	51.0	50.2	49.1	48.1	46.9	45.9	44.7	43.9	42.5	41.5
16.0	48.2	47.8	46.8	46.5	45.7	44.8	43.7	42.5	41.6	40.4	39.5	38.3	37.2
18.0	40.6	40.3	39.3	39.0	38.3	37.3	36.2	35.2	34.3	33.0	32.3	31.1	30.0
20.0	34.6	34.2	33.3	33.0	32.3	31.3	30.3	29.2	28.4	27.2	26.4	25.3	24.3
22.0	29.6	29.2	28.4	28.1	27.3	26.4	25.4	24.4	23.5	22.4	21.7	20.5	19.5
24.0	25.5	25.1	24.2	23.9	23.2	22.3	21.3	20.3	19.4	18.4	17.6	16.5	15.6
26.0	23.1/25.1	22.7/25.1	21.9/25.1	21.6/25.1	20.9/25.1	19.9/25.1	19.0/25.1	18.0/25.1	17.1/25.1	16.1/25.1	15.3/25.1	14.3/25.1	13.3/25.1

■ w/57.90m Tower

Tower Angle (°)	27.4	30.5	33.5	36.6	39.6	42.7	45.7	48.8	51.8	54.9	57.9	61.0
Working radius(m)												
10.0	60.6/10.9	59.7/10.9	59.6/10.9	58.9/10.9	58.0/10.9	57.0/10.9	55.9/10.9	55.1/10.9	53.9/10.9	53.1/10.9	51.9/10.9	50.8/10.9
11.0	60.1	59.2	59.1	58.4	57.5	56.5	55.5	54.6	53.4	52.6	51.4	50.3
12.0	57.8	56.9	56.8	56.0	55.1	54.1	53.1	52.2	51.0	50.2	49.0	47.9
13.0	55.5	54.6	54.5	53.8	52.9	51.9	50.8	49.9	48.8	47.9	46.7	45.6
14.0	53.5	52.5	52.4	51.7	50.8	49.7	48.7	47.8	46.6	45.8	44.6	43.5
15.0	49.9	49.0	48.8	48.2	47.3	46.3	45.2	44.4	43.3	42.4	41.3	40.2
16.0	46.8	45.9	45.6	44.9	43.9	42.8	41.8	40.8	39.6	38.8	37.6	36.5
18.0	39.5	38.6	38.4	37.6	36.6	35.5	34.5	33.6	32.4	31.7	30.5	29.4
20.0	33.6	32.6	32.4	31.7	30.7	29.7	28.7	27.9	26.7	25.9	24.8	23.8
22.0	28.7	27.8	27.5	26.8	25.9	24.9	23.9	23.0	22.0	21.2	20.1	19.2
24.0	24.6	23.7	23.4	22.7	21.9	20.9	19.9	19.1	18.0	17.3	16.2	15.3
26.0	21.1	20.2	20.0	19.3	18.4	17.5	16.5	15.7	14.7	13.9	12.9	12.0
28.0	20.3/26.4	19.4/26.4	19.4/26.4	18.5/26.4	17.6/26.4	16.8/26.4	15.9/26.4	15.0/26.4	14.0/26.4	13.2/26.4	12.2/26.4	11.3/26.4

■ w/60.95m Tower

Tower Angle (°)	30.5	33.5	36.6	39.6	42.7	45.7	48.8	51.8	54.9	57.9	61.0
Working radius(m)											
11.0	47.9/11.3	47.7/11.3	46.9/11.3	46.8/11.3	45.7/11.3	45.8/11.3	45.0/11.3	43.9/11.3	43.1/11.3	41.9/11.3	40.9/11.3
12.0	46.4	46.2	45.4	45.3	44.3	44.3	43.5	42.3	41.6	40.4	39.3
13.0	44.5	44.3	43.5	43.4	42.4	42.4	41.5	40.4	39.6	38.4	37.4
14.0	42.8	42.5	41.7	41.6	40.6	40.6	39.7	38.6	37.8	36.6	35.6
15.0	41.1	40.9	40.0	39.9	38.9	38.9	38.0	36.9	36.1	34.9	33.9
16.0	39.5	39.3	38.4	38.3	37.3	37.3	36.4	35.3	34.5	33.3	32.2
18.0	35.4	35.2	34.4	34.3	33.2	33.2	32.3	31.3	30.5	29.3	28.3
20.0	30.7	30.3	29.5	29.2	28.2	28.0	27.2	26.0	25.4	24.2	23.2
22.0	25.9	25.6	24.8	24.5	23.5	23.3	22.5	21.4	20.7	19.5	18.7
24.0	22.0	21.6	20.8	20.6	19.5	19.4	18.6	17.5	16.8	15.8	14.8
26.0	18.6	18.2	17.5	17.2	16.2	16.0	15.2	14.2	13.5	12.5	11.6
28.0	16.1/27.7	15.7/27.7	15.0/27.7	14.7/27.7	13.7/27.7	13.5/27.7	12.8/27.7	11.7/27.7	11.0/27.7	10.0/27.7	9.2/27.7

Notes — Tower boom top crane capacities

- Capacities on these charts are available when handling load off a 3-sheave machinery provided on 7.30m tower top section with movement of tower boom hoisting/lowering under the condition that luffing jib offset angle to tower boom is 15 degrees.
- Capacities included in these charts are the maximum allowable, and are based on machine standing level on firm supporting surface under ideal job conditions.
- Capacities are in metric tons, and are rated in accordance with European EN13000 Standards in terms of machine stability and structural strength limitations; the figures surrounded by bold lines are based on factors other than those which would cause a tipping condition.
- Capacities are based on freely suspended loads and make no allowance for such factors as the effect of wind, sudden stopping of loads, supporting surface conditions, and operating speeds. Operator must reduce load ratings to take such conditions into account. Deduction from rated capacities must be made for weight of hook block, weighted ball/hook, sling, spreader bar, or other suspended gear.
Hook block weight is as follows:
80t.....1.4ton 35t.....0.9ton 13.5t.....0.6ton
- All capacities are rated for 360° swing.
- Least stable rated condition is over the side.
- An 102.8ton counterweight and 18.0ton carbody weight are required for all capacities on this chart.
- Attachment must be erected and lowered over the ends of the crawler mounting.
- Tower boom and jib configurations shall be in accordance with manufacturer's standard described here in "Tower Boom & Jib Combination Diagram" shown in page 26.
- A simultaneous lift under luffing jib hook and tower boom top crane hook is not allowed.

Tower Boom Top Crane Working Ranges

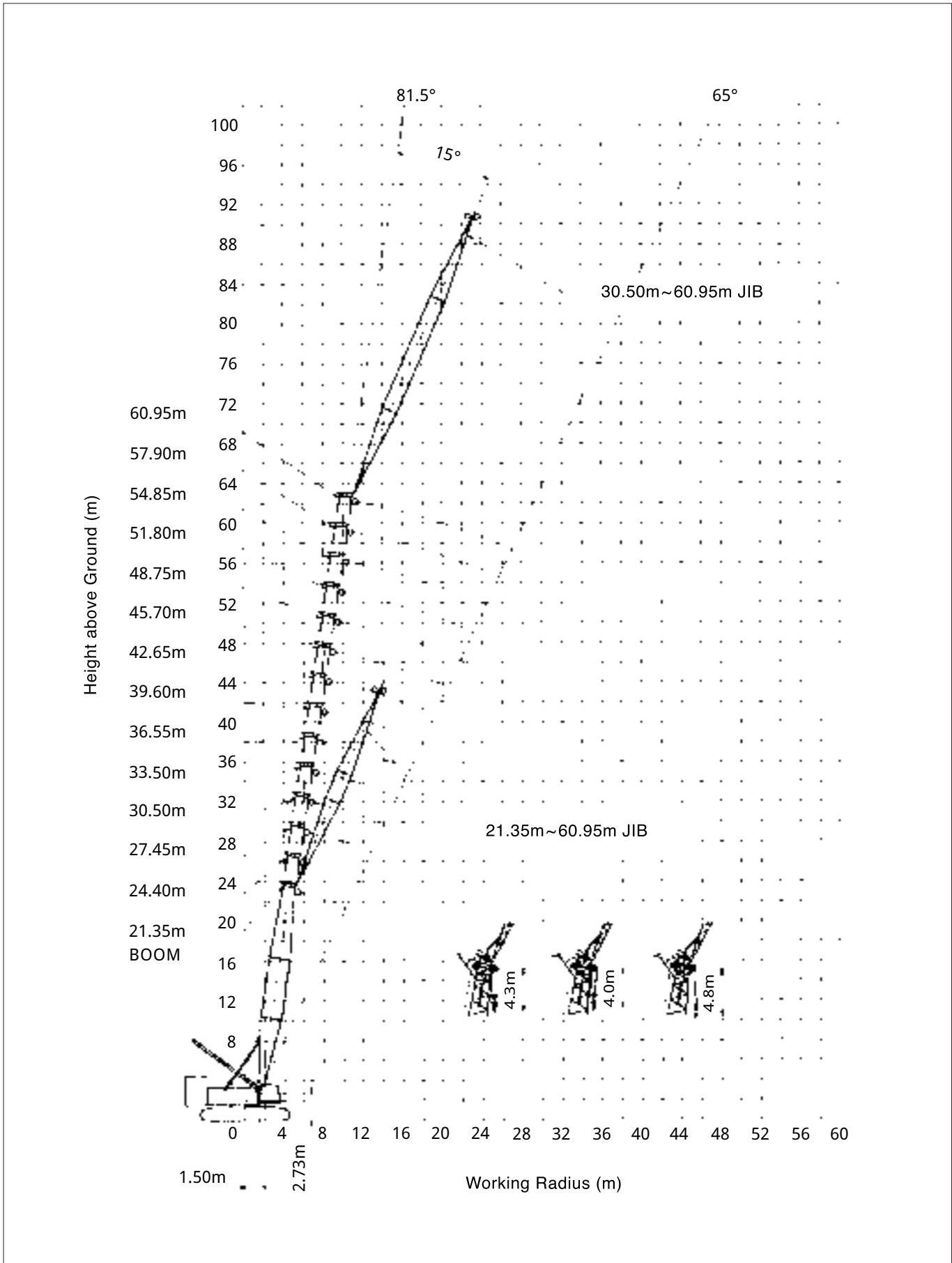

Transport Data

Followings are essential parts for luffing jib attachment.

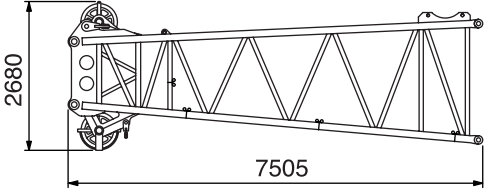
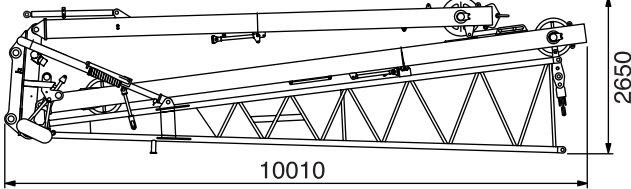
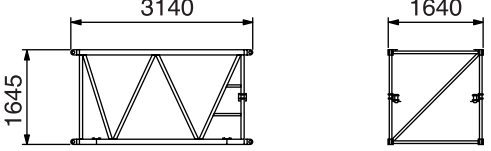
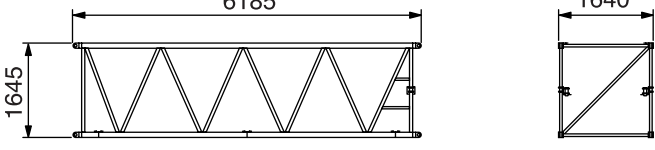
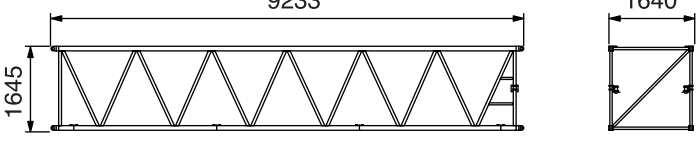
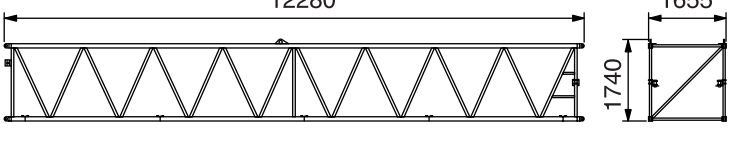
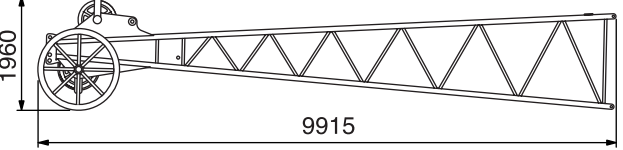
Description	Q'ty	Dimensions(mm)	Mass(kg)
7.30m HD Tower Top section	1	 <p>Width : 2240 (w/out pendant ropes)</p>	3,300
9.15m Luffing Jib Bottom Section (w/front & rear posts) (w/0.32m tower head sect.)	1	 <p>Width : 2070 (w/out pendant ropes)</p>	6,000
3.05m Luffing Jib Extension	1	 <p>(w/out pendant ropes)</p>	300
6.10m Luffing Jib Extension	1	 <p>(w/out pendant ropes)</p>	500
9.15m Luffing Jib Extension	1	 <p>(w/out pendant ropes)</p>	700
12.20m HD Luffing Jib Extension	1	 <p>(w/out pendant ropes)</p>	1,100
9.15m Luffing Jib Top section	1	 <p>Width : 1645 (w/out pendant ropes)</p>	1,700

MEMO

A series of horizontal dotted lines for writing a memo.

Hitachi Sumitomo Heavy Industries Construction Crane Co., Ltd

12-14, Ueno 7-chome, Taito-ku, Tokyo 110-0005, Japan

Phone: 81-3-3845-1387 Facsimile: 81-3-3845-1394

- We are constantly improving our products and therefore reserve the right to change designs and specifications without notice.
- Units in this specification are shown under International System of Units; the figures in parenthesis are under Gravitational System of Units as old one.

Address Inquires to: