

# ***SCX 3500-3***

---

## **HYDRAULIC CRAWLER CRANE**

---

# ***Specifications & Lifting Capacities***

**HITACHI SUMITOMO**



# Variation of The Attachment

Line Speed *	Front (W1)/Rear (W2)	m/min	110
	Boom Hoist (W3)		34 x 2
	Tower Jib Hoist (W4)		55
Swing Speed		min <sup>-1</sup> (rpm)	0.86 (0.86)
Travel Speed High / Low		km/h	0.9/0.45
Gradeability		% (Degree)	30 (17)
Engine Model			CUMMINS QSL9 (Stage IV/Tier 4f)
Engine Rated Output Power		kW/min <sup>-1</sup> (ps/rpm)	272/2000 (370/2000)

Note : Speeds marked with "\*" may vary depending on load applied.

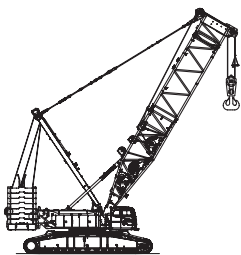

**Hammer Head Specification**

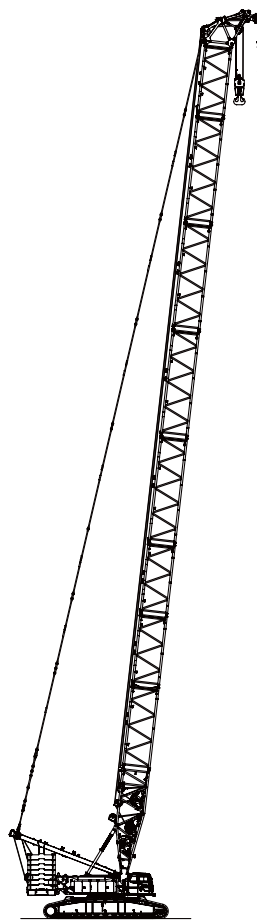

**Crane Specification  
Boom Longest Length with  
Aux. Sheave  
(Rear end Radius: Standard)**

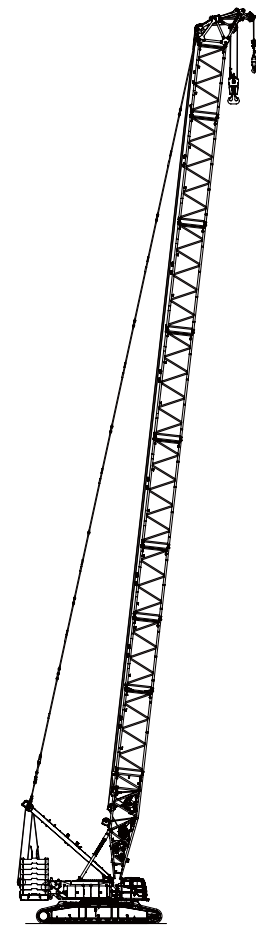

**Crane Specification  
Boom Longest Length with  
Aux. Sheave  
(Rear end Radius: Short)**

Boom Length	m	18
Ground Contact Pressure	kPa (kgf/cm <sup>2</sup> )	136(1.39) (with 350t hook)
Overall Operating Weight	t	Approximately 321

Boom Length	m	24 to 72
Ground Contact Pressure	kPa (kgf/cm <sup>2</sup> )	144 (1.47) (100t + 15t hook attached)
Overall Operating Weight	t	Approximately 341

Boom Length	m	24 to 72
Ground Contact Pressure	kPa (kgf/cm <sup>2</sup> )	144 (1.47) (100t + 15t hook attached)
Overall Operating Weight	t	Approximately 341

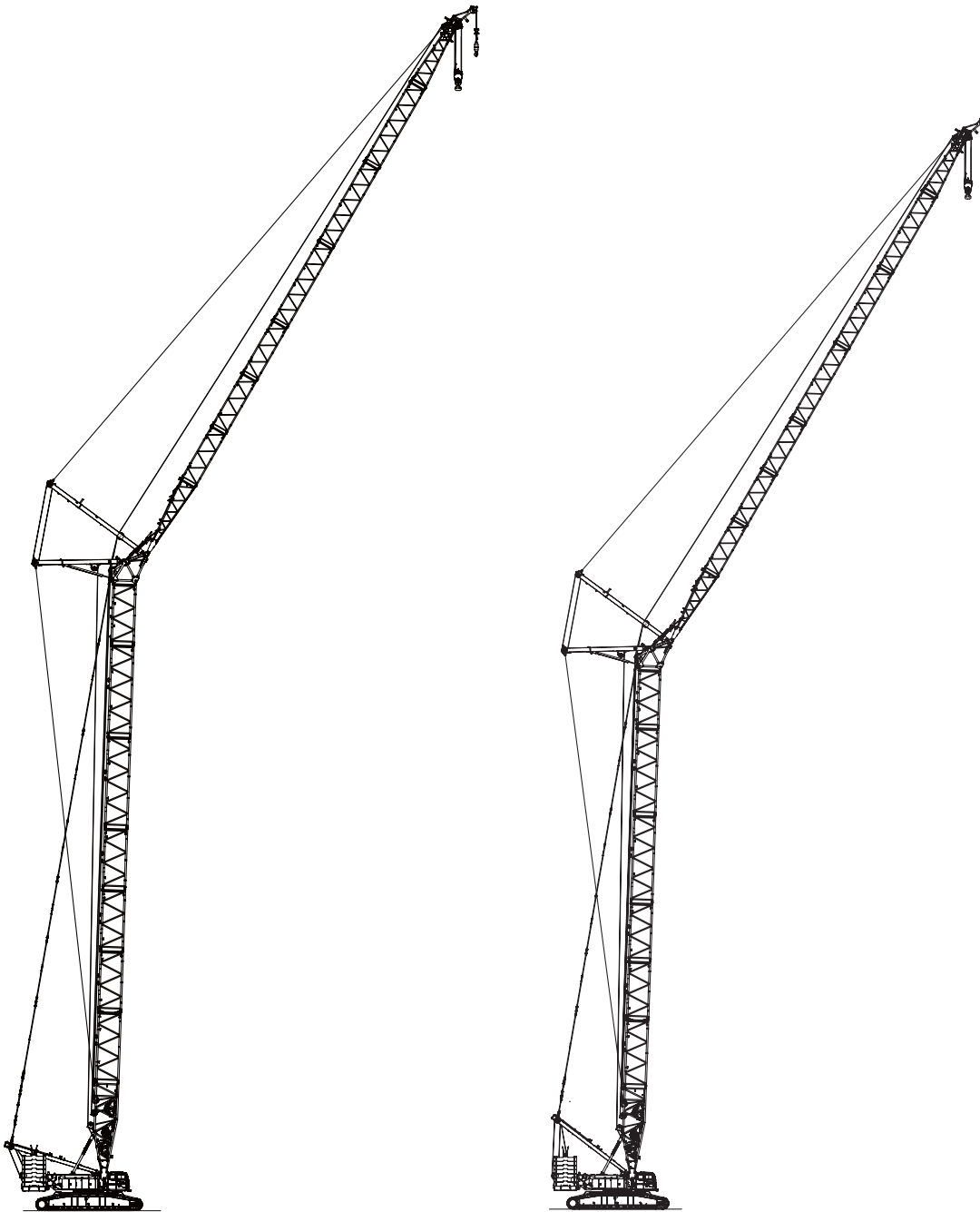

**Tower Specification  
Tower with Tower Jib  
Longest Length  
(Rear end Radius: Standard)**

Tower Length	m	24 to 60
Tower Jib Length	m	24 to 60
Tower + Tower Jib Longest Length	m	60 + 60
Ground Contact Pressure	kPa (kgf/cm <sup>2</sup> )	152 (1.55) (100t + 15t hook attached)
Overall Operating Weight	t	Approximately 360

**Tower Specification  
Tower with Tower Jib  
Longest Length  
(Rear end Radius: Short)**

Tower Length	m	24 to 54
Tower Jib Length	m	24 to 60
Tower + Tower Jib Longest Length	m	54 + 60
Ground Contact Pressure	kPa (kgf/cm <sup>2</sup> )	151 (1.54) (100t + 15t hook attached)
Overall Operating Weight	t	Approximately 357

## VARIATION

<b>Specifications</b>	<b>6</b>
-----------------------	----------

## SPECIFICATIONS

<b>Crane Specifications</b>	<b>7</b>
-----------------------------	----------

<b>Dimensions and Specifications</b>	<b>7</b>
<b>Boom Standard Configurations</b>	<b>8</b>
<b>Lowerable Hook Mass</b>	<b>9</b>
<b>Working Ranges</b>	<b>10</b>
■ Main Boom (Rear end Radius: Standard)	10
■ Aux. Sheave (Rear end Radius: Standard)	11
■ Main Boom with Aux. Sheave (Rear end Radius: Standard)	12
■ Main Boom (Rear end Radius: Short)	13
■ Aux. Sheave (Rear end Radius: Short)	14
■ Main Boom with Aux. Sheave (Rear end Radius: Short)	15
<b>Gross Rated Load Table</b>	<b>16</b>
■ Main Boom (Rear end Radius: Standard)	16
■ Aux. Sheave (Rear end Radius: Standard)	17
■ Main Boom with Aux. Sheave (Rear end Radius: Standard)	18
■ Main Boom (Rear end Radius: Short)	19
■ Aux. Sheave (Rear end Radius: Short)	20
■ Main Boom with Aux. Sheave (Rear end Radius: Short)	21

<b>Tower Specifications</b>	<b>22</b>
-----------------------------	-----------

<b>Dimensions and Specifications</b>	<b>22</b>
<b>Tower Standard Configurations</b>	<b>23</b>
<b>Restriction of Hook Usage</b>	<b>24</b>
<b>Lowerable Hook Mass</b>	<b>25</b>
<b>Working Ranges</b>	<b>26</b>
■ Rear end Radius: Standard	26
■ Rear end Radius: Short	27
<b>Gross Rated Load Table</b>	<b>28</b>
■ Tower 24 m (Rear end Radius: Standard)	28
■ Tower 30 m (Rear end Radius: Standard)	30
■ Tower 36 m (Rear end Radius: Standard)	32
■ Tower 42 m (Rear end Radius: Standard)	34
■ Tower 48 m (Rear end Radius: Standard)	36
■ Tower 54 m (Rear end Radius: Standard)	38
■ Tower 60 m (Rear end Radius: Standard)	40

- Tower 24 m (Rear end Radius: Short) ..... 42
- Tower 30 m (Rear end Radius: Short) ..... 44
- Tower 36 m (Rear end Radius: Short) ..... 46
- Tower 42 m (Rear end Radius: Short) ..... 48
- Tower 48 m (Rear end Radius: Short) ..... 50
- Tower 54 m (Rear end Radius: Short) ..... 52

**TECHNICAL DATA**

<b>Weights and Dimensions of Disassembled Units</b>	<b>54</b>
Weights and Dimensions List .....	54
<b>Equipment List</b>	<b>58</b>
Standard and Optional Equipment .....	58

# Specifications

## Engine

Model	CUMMINS QSL9
Type	4-cycle, water-cooled, Direct-injection, Turbo-charger Diesel engine
Displacement	8.9 Liters
Rated output	272 kW / 2,000 min <sup>-1</sup> (370 PS / 2,000 rpm)
Fuel tank Capacity	550 Liters
Notes	Compliant with engine emission gas regulations for USA Tier4f, EU StageIV and Japan 2014 Code.

## Control

Control System	Main actuators are controlled by hydraulic pilot system. Working speeds can be precisely controlled by lever stroke and volume dial. Safety devices are securely operated by combined various electronic controls with hydraulic system.
Control Levers	Designed and layout on ergonomics. Arm chair lever type is standard.
Display Panel Design	8 inches size. Located to check working state easily without disturbing the view of the operator.

## Hydraulic System

Hydraulic Tank	350 Liters		
Hydraulic Pump Capacity	Maximum pressure	31.4 MPa	
	P1	320 l / min	W3, W4 winch, Travel (R)
	P2	320 l / min	W1, W2 winch, Travel(L), Quick draw
	P3	158 l / min	Swing, Reeving winch, Cylinders
	P4	74 l / min	Fan drive(Radiator, Oil cooler)
	P5	44 l / min	Pilot

## Winch

	W1 (Front)	W2 (Rear)	W3 (Hoist)	W4 (Jib Hoist)
Rope diameter	28 mm	28 mm	28 mm	28 mm
Rope length	335 m	610 m	490 m	370 m
Rope speed	110m/min	110m/min		
Rated linepull (1st layer)	147 kN (230 kN)	147 kN (230 kN)		

High speed lifting and lowering is possible by ECO mode with low engine speed under light load.

Hydraulic motor with wet multiple disc brake and planetary reduction gears inside of winch drum.

## Swing Device

0.86 rpm
3 sets of hydraulic motor with wet multiple disc brake + planetary reduction gears and turn table bearing with external teeth.
Precise swing operation is possible by swing brake with pedal.

## Mast

Easy assembly for front attachments.
Crawler sideframe self assembly is possible by Quick draw(Opt).
By using Quick draw system, assembly work can be done by helper crane to install 19.7 ton base counter weight.

## Counter Weight

Counter weight	Total weight	145.0 t
	Base weight	19.7 t × 1
Lower weight	Weight	8.95 t × 14
	Total weight	25.0 t
	Weight	12.5 t × 2

## Carbody

High tensile steel box structure
Jack up device
Pin connection with crawler sideframe by hook on system

## Crawler Sideframe

Crawler sideframe	High tensile steel box structure With travel device and pin connection and connection cylinders	
Shoes	1250mm Flat shoes	
Upper roller	7 pieces for each side Double flange type 2 cantilever type 5	
Lower roller	15 pieces for each side Double flange type with plane bearing and floating seal for lifetime lubrication	
	Forging and heat treated steel	
Travel device	1unit for each side	
	Hydraulic motor with wet multiple disc brake + Planetary reduction gears	
	Travel speed	High : 0.9 km/hr. Lower : 0.45 km/hr.
	Gradability	30 %

# Crane Specifications

## Dimensions and Specifications

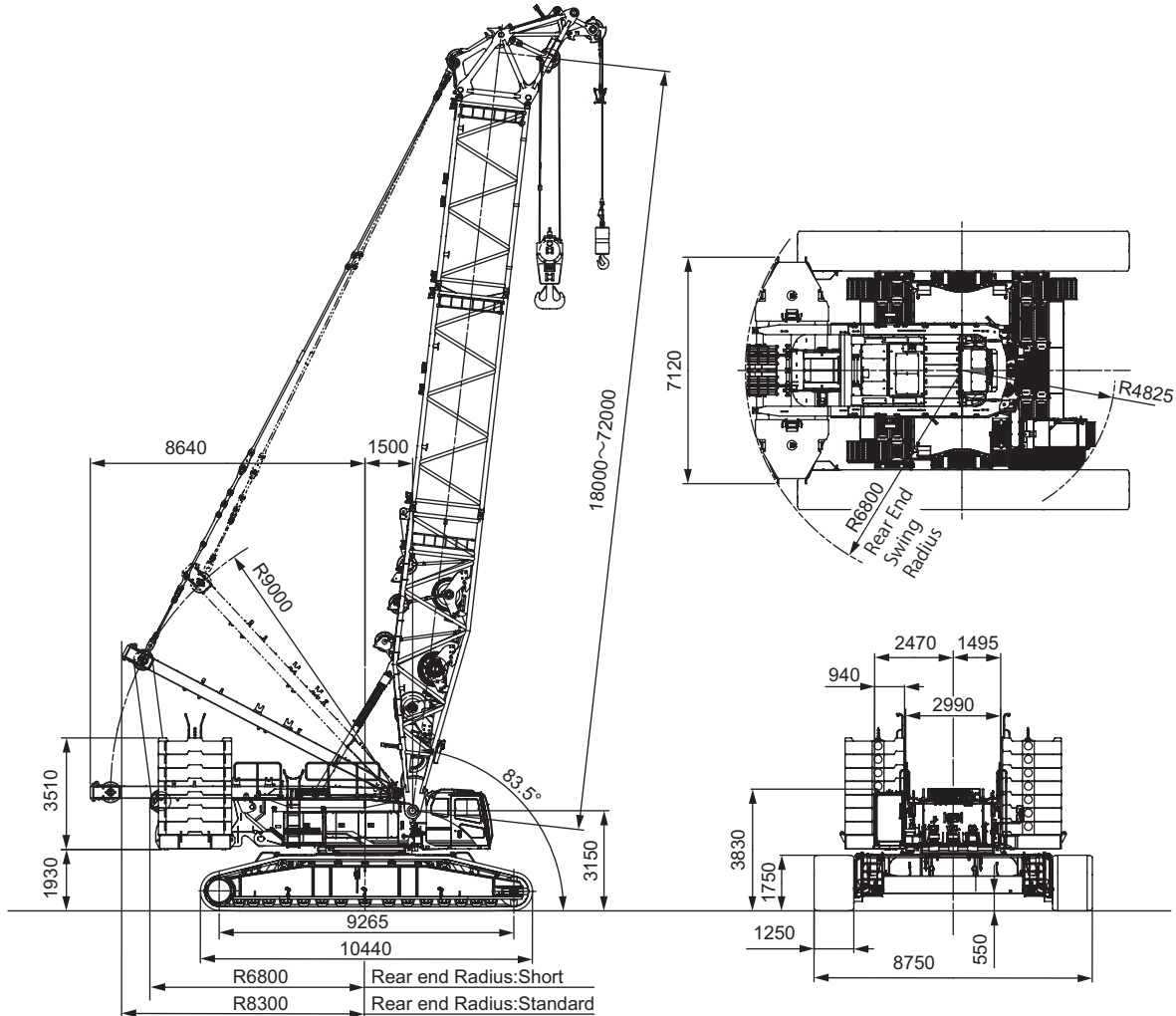

### Crane Specifications

Max. Lifting Load × Working Radius (Boom top attached)	t × m	180 × 5.9
Max. Lifting Load × Working Radius (Hammer head attached)	t × m	350 × 5.0
Basic Boom Length (Boom top attached)	m	24
Max. Boom Length (Boom top attached)	m	72
Basic Boom Length (Hammer head attached)	m	18
Ground Contact Pressure (Boom top attached)	kPa (kgf/cm <sup>2</sup> )	135 (1.38) (24m Boom with 180 t Hook)
Ground Contact Pressure (Hammer head attached)	kPa (kgf/cm <sup>2</sup> )	136 (1.39) (18m Boom with 350 t Hook)
Overall Operating Weight (Boom top attached)	t	Approximately 320 (24m Boom with 180 t Hook)
Overall Operating Weight (Hammer head attached)	t	Approximately 321 (18m Boom with 350 t Hook)

### Hook Mass

350 t	4,440 kg
180 t	3,340 kg
100 t	3,110 kg
45 t	2,170 kg
15 t	620 kg

NOTE : Data is expressed in SI units followed by conventional units in ( ).

### Number of Front/Rear Winch Rope and Lifting Load

Hook Capacity	Maximum Rated Load (ton)												
	13 falls	12 falls	11 falls	10 falls	9 falls	8 falls	7 falls	6 falls	5 falls	4 falls	3 falls	2 falls	1 fall
180 t	180	170	157	144	131	118	104	90	76	61	-	-	-
100 t	-	-	-	-	-	-	100	90	76	61	46	31	-
45 t	-	-	-	-	-	-	-	-	-	-	45	31	-
15 t	-	-	-	-	-	-	-	-	-	-	-	-	15

# Boom Standard Configurations

## Crane Specification Boom

Boom	
Boom Length (m)	Boom Configurations
18	
24	
30	
36	
42	
48	
54	
60	
66	
72	

Aux. Sheave Installable Boom Length										
Boom Length (m)	18	24	30	36	42	48	54	60	66	72
With Aux. Sheave	×	○	○	○	○	○	○	○	○	○

( ○ : Attachable × : Not Attachable )

Dimensions Not Shown In The Figure		
Symbols	Boom Length (m)	Note
HB9.5	9.5	Boom Base
HH1.5	1.5	Hammer Head
HT1.5	1.5	Boom Top
H6	6	Boom Insert
H6B	6	Boom Insert B
H9	9	Boom Insert
HR7	7	Reducer



## Lowerable Hook Mass

Unit:ton

Boom Length (m)	No. of Reeved Lines												
	1 fall	2 falls	3 falls	4 falls	5 falls	6 falls	7 falls	8 falls	9 falls	10 falls	11 falls	12 falls	13 falls
24	0.6	2.1	2.1	3.1	3.1	3.1	3.1	3.3	3.3	3.3	3.3	3.3	3.3
30	0.6	2.1	2.1	3.1	3.1	3.1	3.1	3.3	3.3	3.3	3.3	3.3	3.3
36	0.6	2.1	2.1	3.1	3.1	3.1	3.1	3.3	3.3	3.3	3.3	3.3	3.3
42	0.6	2.1	2.1	3.1	3.1	3.1	3.1	3.3	3.3	3.3	3.3	3.3	-
48	0.6	2.1	2.1	3.1	3.1	3.1	3.1	3.3	3.3	3.3	3.4	-	-
54	0.6	2.1	2.1	3.1	3.1	3.1	3.1	3.3	3.3	-	-	-	-
60	0.6	2.1	2.1	3.1	3.1	3.1	3.1	3.3	-	-	-	-	-
66	0.6	2.1	2.1	3.1	3.1	3.1	3.1	-	-	-	-	-	-
72	0.6	2.1	2.1	3.1	3.1	3.1	3.2	-	-	-	-	-	-

# Working Ranges

## ■ Main Boom (Rear end Radius: Standard)

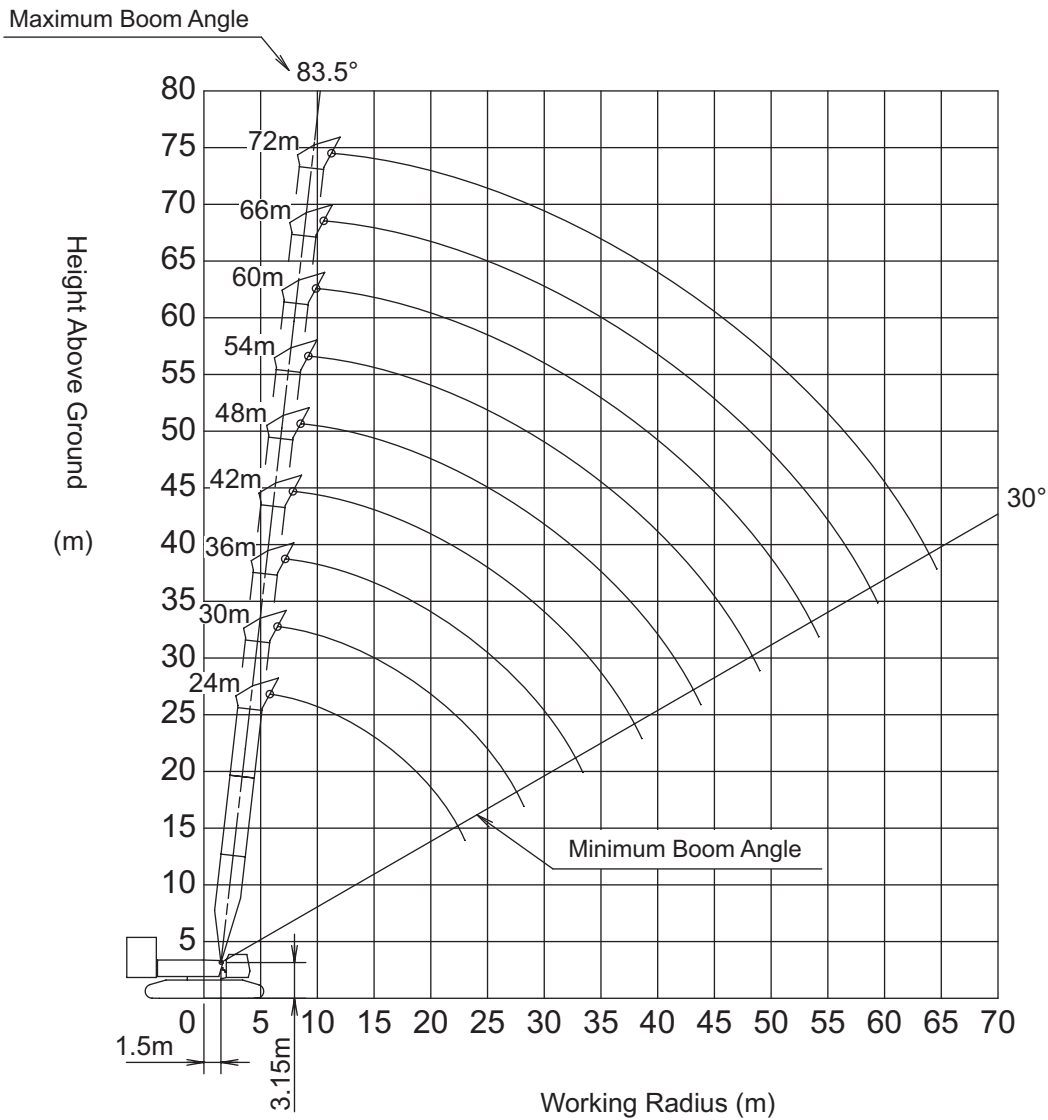
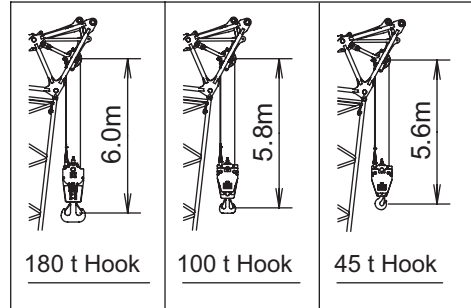

■ Aux. Sheave (Rear end Radius: Standard)

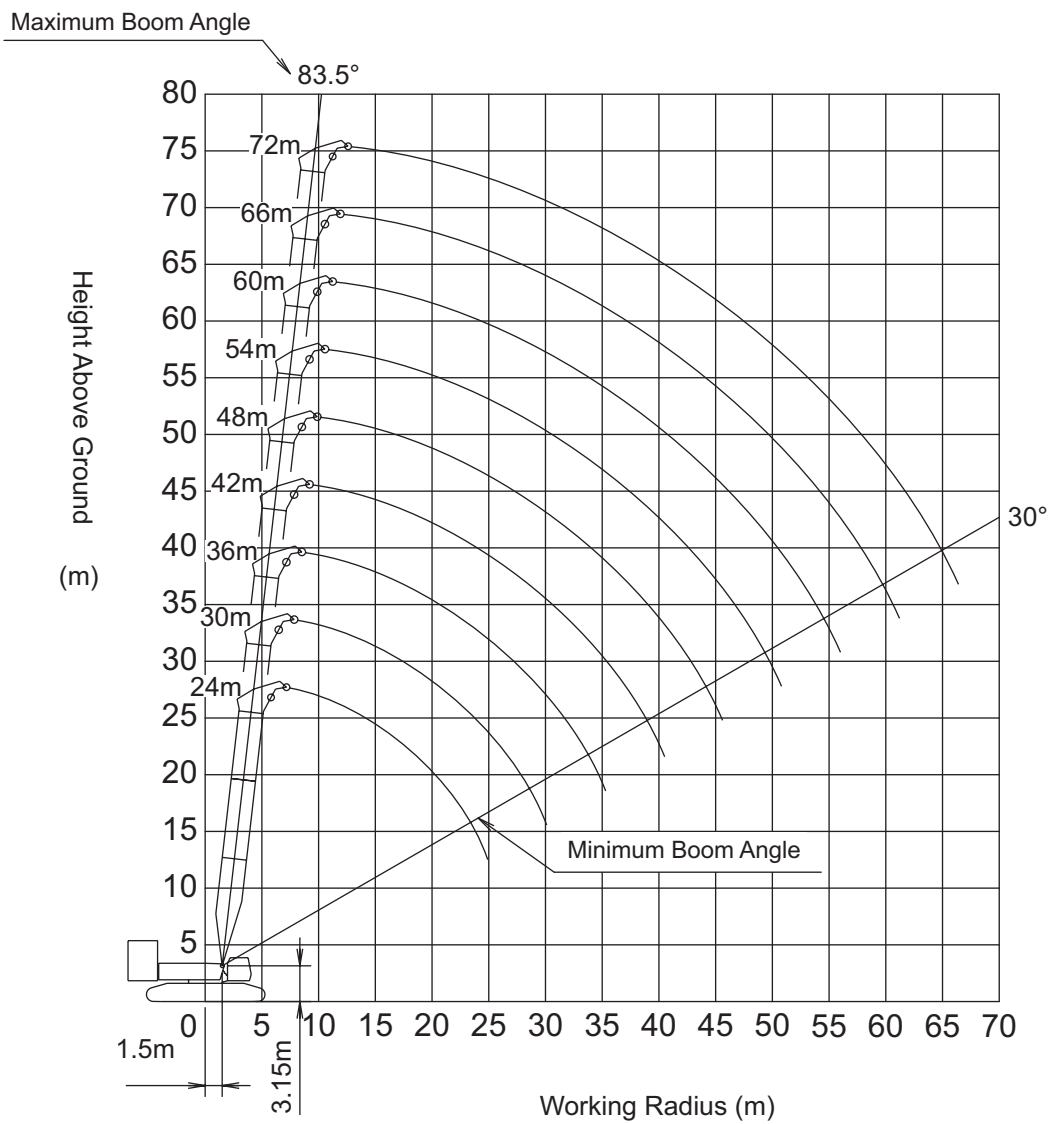
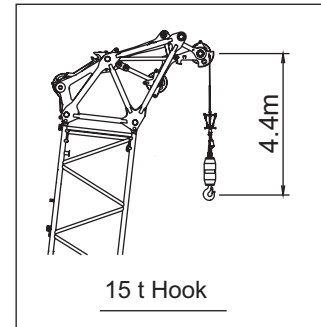

■ Main Boom with Aux. Sheave (Rear end Radius: Standard)

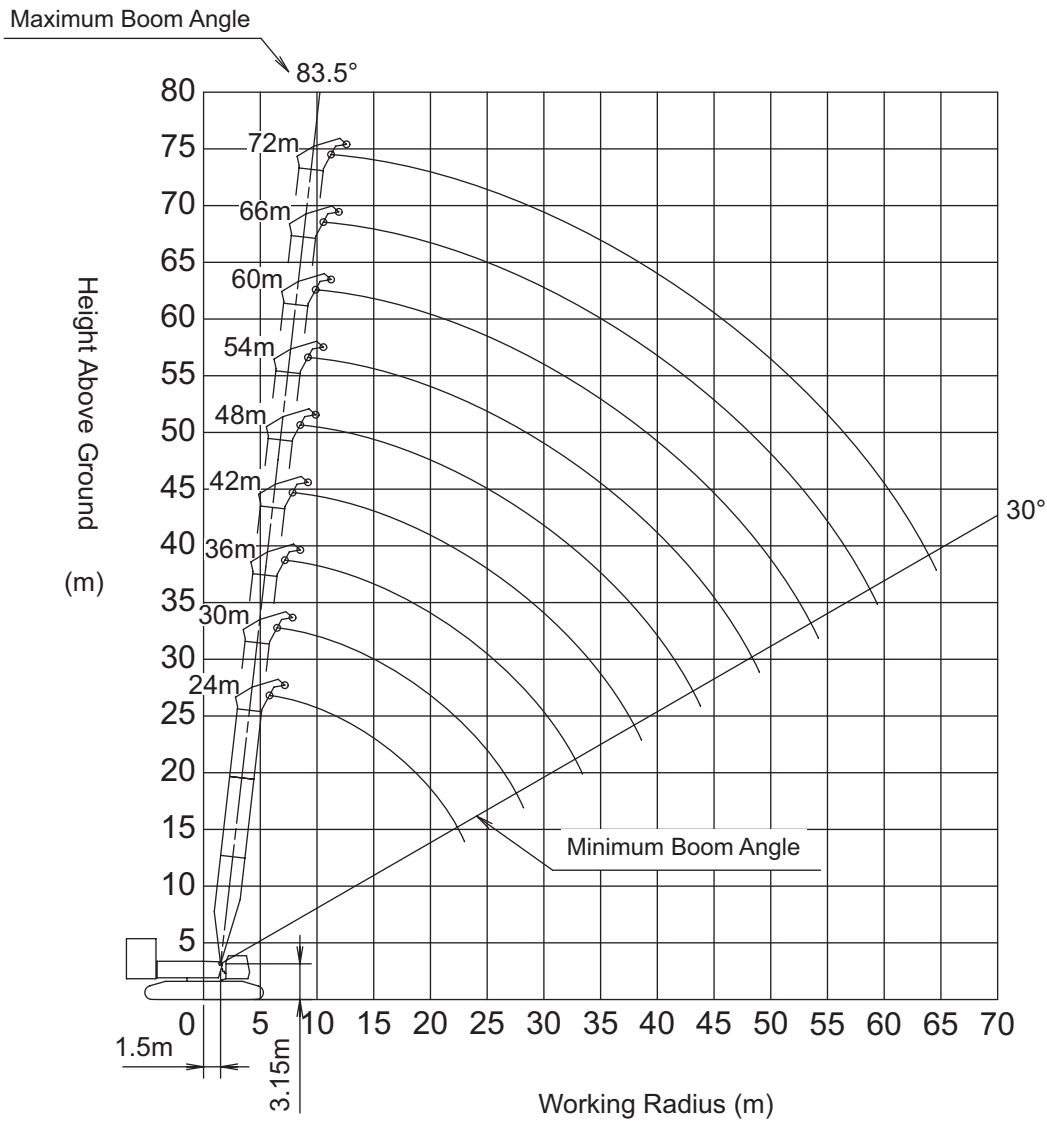
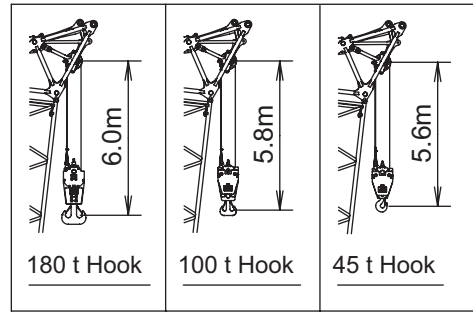

■ Main Boom (Rear end Radius: Short)

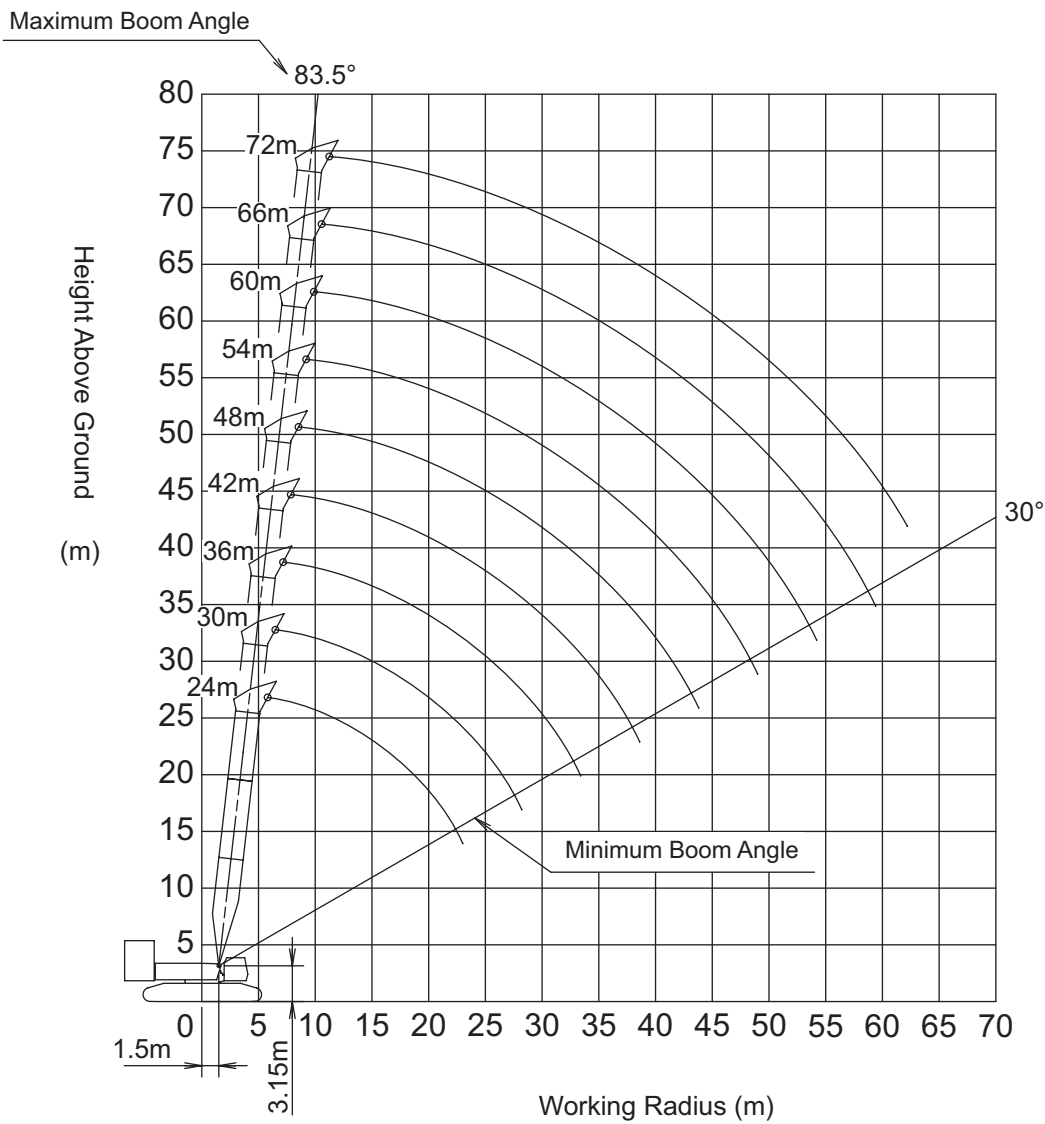
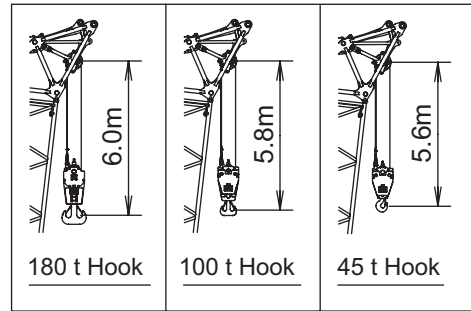

■ Aux. Sheave (Rear end Radius: Short)

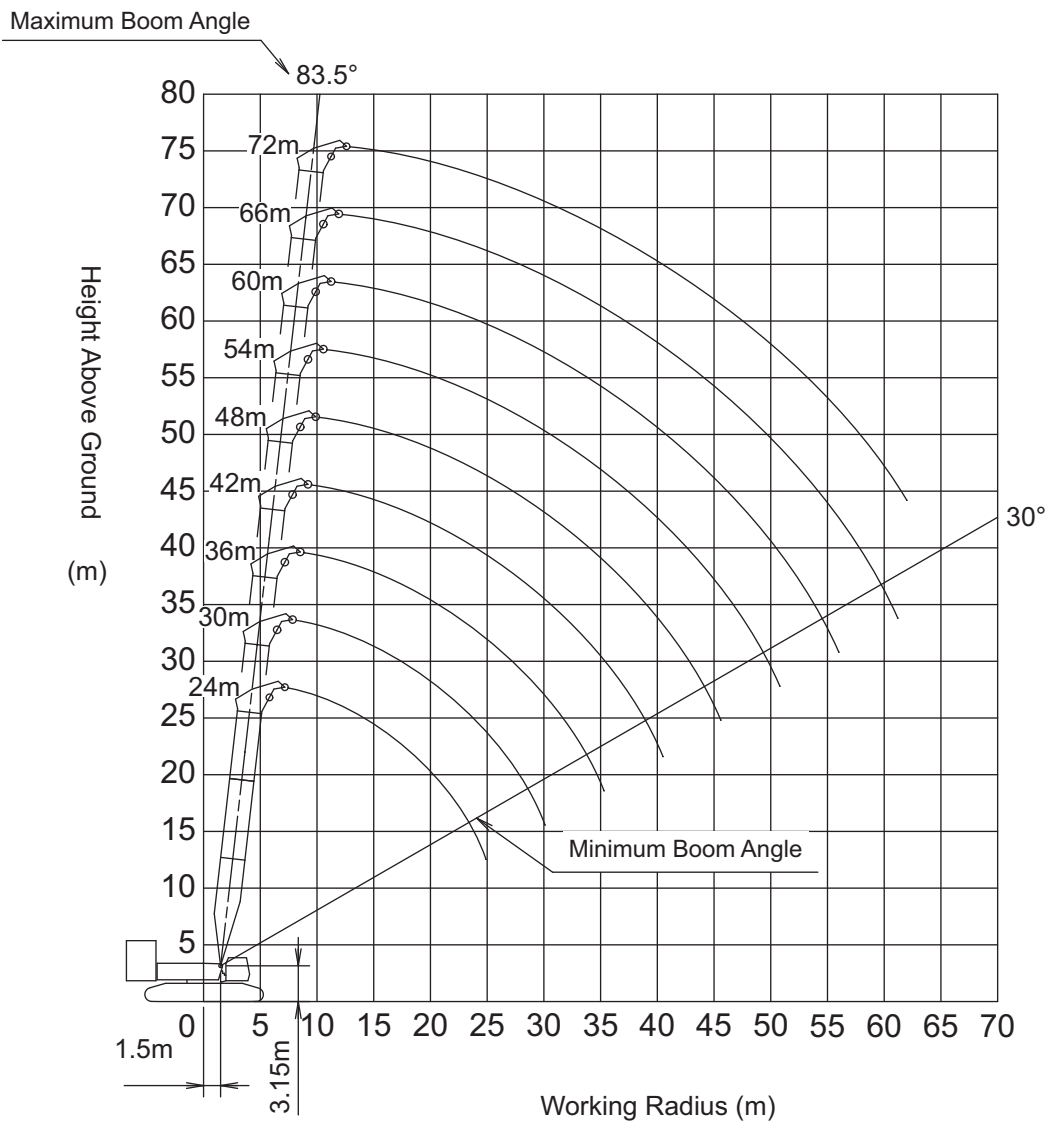
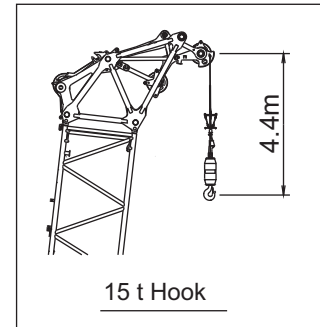

■ Main Boom with Aux. Sheave (Rear end Radius: Short)

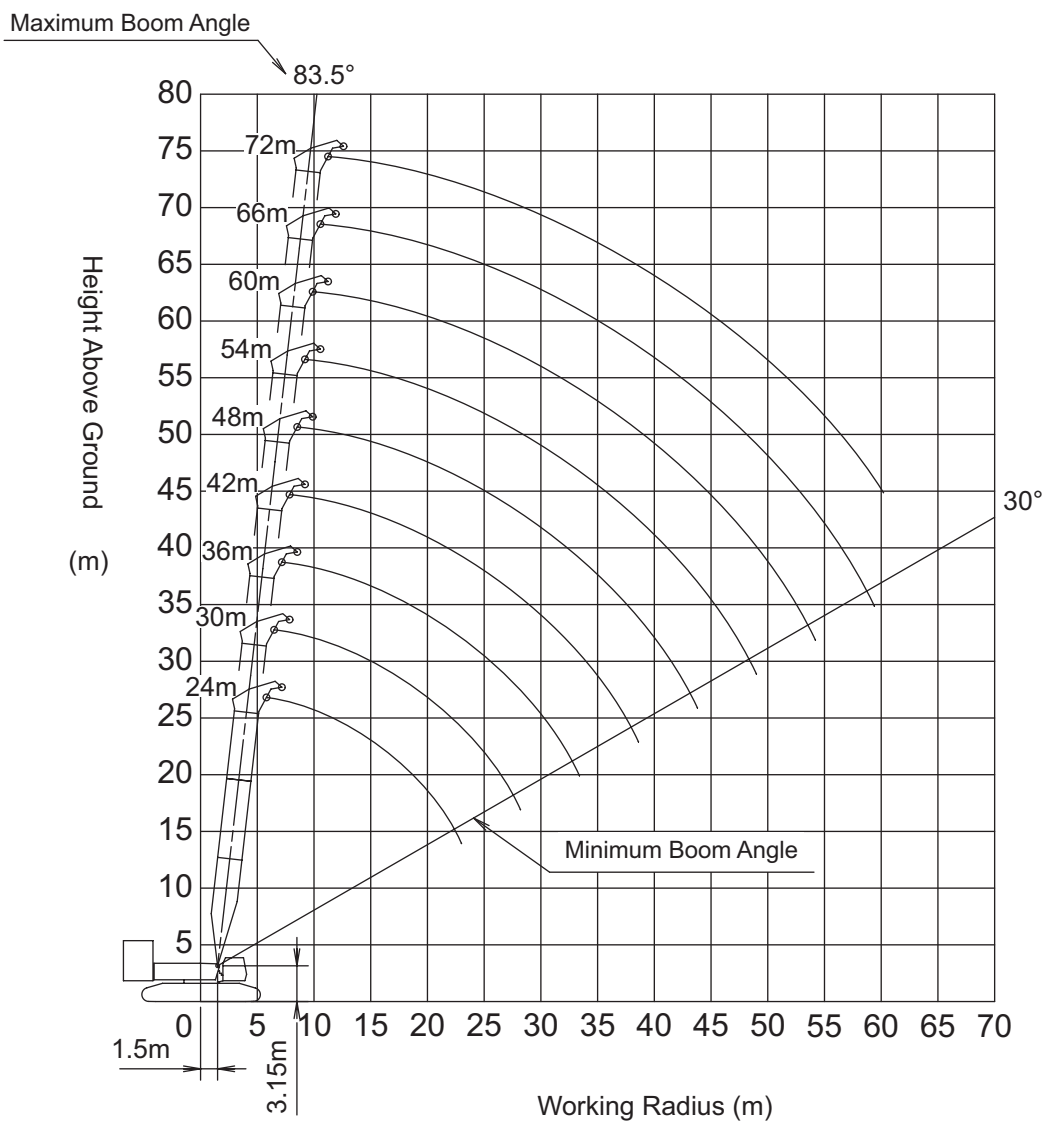
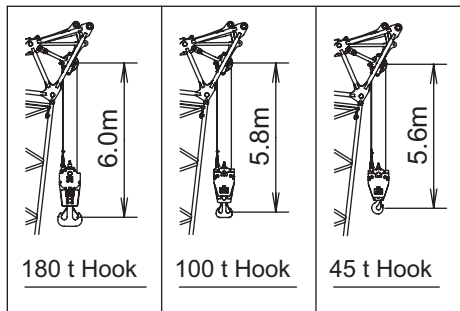

# Gross Rated Load Table

## ■ Main Boom (Rear end Radius: Standard)



Unit: ton

Working Radius(m)	Boom Length (m)										Working Radius(m)	
	Hammer Head	Boom Top										
		18	24	30	36	42	48	54	60	66		72
-		5.9m x 180.0t										-
5	350.0	180.0	6.5m x 180.0t									5
6	283.6	180.0	180.0t	7.2m x 180.0t	7.9m x 170.0t							6
7	244.7	180.0	180.0	180.0t	170.0t	8.6m x 157.0t						7
8	214.9	180.0	180.0	180.0	170.0	157.0t	9.3m x 131.0t	9.9m x 118.0t				8
9	181.5	180.0	180.0	180.0	170.0	157.0	131.0t	118.0t	10.6m x 104.0t	11.3m x 102.9t		9
10	154.8	180.0	180.0	180.0	170.0	157.0	131.0	118.0	104.0t	101.7t		10
12	118.2	155.1	154.6	153.8	144.3	143.1	131.0	118.0	104.0	101.7		12
14	93.2	130.6	129.2	128.4	121.1	119.9	112.8	106.2	104.0	98.5		14
16	76.4	109.9	109.8	108.9	103.7	102.6	97.0	91.7	90.4	85.4		16
18	17.7m x 65.8t	92.5	92.4	91.9	90.3	89.2	84.6	80.2	79.0	74.8		18
20		79.4	79.3	78.7	78.3	77.6	74.6	70.9	69.7	66.1		20
22		69.0	69.1	68.5	68.0	67.3	66.4	65.2	62.0	58.9		22
24		23.0m x 64.7t	60.8	60.3	59.8	59.1	58.4	57.6	55.6	52.8		24
26			54.1	53.5	53.1	52.3	51.7	50.9	50.1	47.6		26
28			48.4	47.9	47.5	46.7	46.0	45.2	44.6	43.6		28
30			28.2m x 47.9t	43.2	42.7	41.9	41.3	40.5	39.8	38.8		30
32				39.1	38.6	37.9	37.2	36.4	35.7	34.7		32
34				33.4m x 36.6t	35.1	34.3	33.6	32.8	32.1	31.1		34
36					32.0	31.2	30.5	29.7	29.0	28.0		36
38					29.3	28.5	27.8	26.9	26.3	25.2		38
40					38.6m x 28.6t	26.1	25.4	24.5	23.9	22.8		40
42						24.0	23.2	22.3	21.7	20.6		42
44						43.8m x 22.2t	21.3	20.4	19.7	18.7		44
46							19.5	18.6	17.9	16.9		46
48							17.9	17.0	16.3	15.3		48
50							49.0m x 17.2t	15.6	14.9	13.8		50
52								14.3	13.6	12.5		52
54								13.0	12.3	11.3		54
56								54.2m x 12.9t	11.2	10.2		56
58									10.2	9.1		58
60									59.4m x 9.5t	8.2		60
62										7.3		62
64										6.5		64
66										64.6m x 6.2t		66
68												68

- The rated loads are determined according to EN13000 rating on the condition that the machine is stationed on firm, level ground.
- To calculate the maximum load that can actually be lifted, deduct mass of all lifting accessories, such as hook, from figures shown above.
- The figures surrounded by bold lines are based on factors other than those which would cause a tipping condition.
- Working radius is the horizontal distance from the swing center to the center of gravity of a lifted load.
- The 145 ton counter weight and 25 ton lower weight are required for all capacities on these charts.
- Figures described as OOm x OOt in the tables indicate "working radius" m x "rated load" ton.
- Correlation between the number of reeved lines, maximum rated loads, hook mass are shown in the table below.

Hook Capacity	Hook Mass(ton)	Maximum Rated Load (ton)												
		13falls	12falls	11falls	10falls	9falls	8falls	7falls	6falls	5falls	4falls	3falls	2falls	1fall
180t	3.34	180	170	157	144	131	118	104	90	76	61	-	-	-
100t	3.11	-	-	-	-	-	-	100	90	76	61	46	31	-
45t	2.17	-	-	-	-	-	-	-	-	-	-	45	31	-
15t	0.62	-	-	-	-	-	-	-	-	-	-	-	-	15

- The necessary mass to lower the hook refers "Lowerable Hook Mass" on page 9.
- The rated total load when the operation being performed with the rear post support pendant attached is the value remaining when the value in chart below is deducted from the rated total load chart.

Boom Length (m)	18	24	30	36	42	48	54	60	66	72
Equivalent Mass (ton)	0.2	0.3	0.5	0.7	0.8	0.9	1.2	1.4	1.6	1.7

- 18m boom ... with Hammer Head Boom, 350t Hook, and 28 falls.



■ Aux. Sheave (Rear end Radius: Standard)



Unit: ton

Working Radius(m)	Boom Length (m)									Working Radius(m)
	24	30	36	42	48	54	60	66	72	
7.5	15.0	8.2m x	8.9m x							7.5
8	15.0	15.0t	15.0t	9.5m x						8
9	15.0	15.0	15.0	15.0t	10.2m x	10.9m x	11.6m x			9
10	15.0	15.0	15.0	15.0	15.0t	15.0t	15.0t	12.3m x	12.9m x	10
12	15.0	15.0	15.0	15.0	15.0	15.0	15.0	15.0t	15.0t	12
14	15.0	15.0	15.0	15.0	15.0	15.0	15.0	15.0	15.0	14
16	15.0	15.0	15.0	15.0	15.0	15.0	15.0	15.0	15.0	16
18	15.0	15.0	15.0	15.0	15.0	15.0	15.0	15.0	15.0	18
20	15.0	15.0	15.0	15.0	15.0	15.0	15.0	15.0	15.0	20
22	15.0	15.0	15.0	15.0	15.0	15.0	15.0	15.0	15.0	22
24	15.0	15.0	15.0	15.0	15.0	15.0	15.0	15.0	15.0	24
26	24.9m x	15.0	15.0	15.0	15.0	15.0	15.0	15.0	15.0	26
28	15.0t	15.0	15.0	15.0	15.0	15.0	15.0	15.0	15.0	28
30		15.0	15.0	15.0	15.0	15.0	15.0	15.0	15.0	30
32		30.1m x	15.0	15.0	15.0	15.0	15.0	15.0	15.0	32
34		15.0t	15.0	15.0	15.0	15.0	15.0	15.0	15.0	34
36			35.3m x	15.0	15.0	15.0	15.0	15.0	15.0	36
38			15.0t	15.0	15.0	15.0	15.0	15.0	15.0	38
40				15.0	15.0	15.0	15.0	15.0	15.0	40
42				40.5m x	15.0	15.0	15.0	15.0	15.0	42
44				15.0t	15.0	15.0	15.0	15.0	15.0	44
46					45.6m x	15.0	15.0	15.0	15.0	46
48					15.0t	15.0	15.0	15.0	15.0	48
50						15.0	15.0	14.8	13.7	50
52						50.8m x	14.1	13.4	12.4	52
54						15.0t	12.8	12.1	11.1	54
56							11.7	11.0	9.9	56
58								9.9	8.9	58
60								8.9	7.9	60
62								61.2m x	7.0	62
64								8.4t	6.2	64
66									5.4	66
68									66.4m x	68
70									5.2t	70

1. The rated loads are determined according to EN13000 rating on the condition that the machine is stationed on firm, level ground.
2. To calculate the maximum load that can actually be lifted, deduct mass of all lifting accessories, such as boom hook and jib hook, from figures shown above.
3. The figures surrounded by bold lines are based on factors other than those which would cause a tipping condition.
4. Working radius is the horizontal distance from the swing center to the center of gravity of a lifted load.
5. The 145 ton counter weight and 25 ton lower weight are required for all capacities on these charts.
6. Figures described as OOm x OOt in the tables indicate "working radius" m x "rated load" ton.
7. Hook mass are shown in the table below.

Hook Capacity	Hook Mass(ton)
180t	3.34
100t	3.11
45t	2.17
15t	0.62

8. The rated total load when the operation being performed with the rear post support pendant attached is the value remaining when the value in chart below is deducted from the rated total load chart.

Boom Length (m)	24	30	36	42	48	54	60	66	72
Equivalent Mass (ton)	0.3	0.5	0.7	0.8	0.9	1.2	1.4	1.6	1.7

■ Main Boom with Aux. Sheave (Rear end Radius: Standard)



Unit: ton

Working Radius(m)	Boom Length (m)									Working Radius(m)	
	24	30	36	42	48	54	60	66	72		
5.9	180.0	6.5m x 180.0t									5.9
6	180.0	180.0t	7.2m x 180.0t	7.9m x 170.0t							6
7	180.0	180.0	180.0t	170.0t	8.6m x 157.0t						7
8	180.0	180.0	180.0	170.0	157.0t	9.3m x 131.0t	9.9m x 118.0t				8
9	180.0	180.0	180.0	170.0	157.0	131.0t	118.0t	10.6m x 104.0t	11.3m x 101.9t		9
10	180.0	180.0	180.0	170.0	157.0	131.0	118.0	104.0t	100.7t		10
12	154.6	154.1	153.2	143.2	141.8	131.0	118.0	104.0	100.7		12
14	129.4	128.2	127.3	120.0	118.6	111.6	105.0	103.6	97.5		14
16	109.2	108.8	107.7	102.6	101.4	95.8	90.5	89.2	84.2		16
18	91.8	91.7	91.1	89.2	88.0	83.4	79.1	77.8	73.6		18
20	78.7	78.6	78.0	77.5	76.8	73.5	69.8	68.5	64.9		20
22	68.4	68.4	67.8	67.3	66.6	65.3	64.0	60.9	57.7		22
24	23.0m x 64.1t	60.2	59.6	59.1	58.3	57.7	56.9	54.5	51.6		24
26		53.5	52.9	52.4	51.6	50.9	50.1	49.0	46.4		26
28		47.8	47.3	46.8	46.0	45.3	44.5	43.8	42.7		28
30		28.2m x 47.3t	42.6	42.1	41.3	40.6	39.7	39.0	38.0		30
32			38.5	38.0	37.2	36.5	35.6	34.9	33.9		32
34			33.4m x 36.0t	34.5	33.7	33.0	32.1	31.4	30.3		34
36				31.5	30.6	29.9	29.0	28.3	27.2		36
38				28.8	27.9	27.1	26.3	25.6	24.5		38
40				38.6m x 28.0t	25.5	24.7	23.8	23.1	22.1		40
42					23.4	22.6	21.7	21.0	19.9		42
44					43.8m x 21.7t	20.7	19.7	19.0	18.0		44
46						18.9	18.0	17.3	16.2		46
48						17.4	16.4	15.7	14.6		48
50						49.0m x 16.6t	15.0	14.2	13.2		50
52							13.7	12.9	11.8		52
54							12.5	11.7	10.6		54
56							54.2m x 12.4t	10.6	9.5		56
58								9.6	8.5		58
60								59.4m x 8.9t	7.5		60
62									6.7		62
64									5.9		64
66									64.6m x 5.6t		66
68											68

- The rated loads are determined according to EN13000 rating on the condition that the machine is stationed on firm, level ground.
- To calculate the maximum load that can actually be lifted, deduct mass of all lifting accessories, such as hook, from figures shown above.
- The figures surrounded by bold lines are based on factors other than those which would cause a tipping condition.
- Working radius is the horizontal distance from the swing center to the center of gravity of a lifted load.
- The 145 ton counter weight and 25 ton lower weight are required for all capacities on these charts.
- Figures described as OOm x OOt in the tables indicate "working radius" m x "rated load" ton.
- Correlation between the number of reeved lines, maximum rated loads, hook mass are shown in the table below.

Hook Capacity	Hook Mass(ton)	Maximum Rated Load (ton)												
		13falls	12falls	11falls	10falls	9falls	8falls	7falls	6falls	5falls	4falls	3falls	2falls	1fall
180t	3.34	180	170	157	144	131	118	104	90	76	61	-	-	-
100t	3.11	-	-	-	-	-	-	100	90	76	61	46	31	-
45t	2.17	-	-	-	-	-	-	-	-	-	-	45	31	-
15t	0.62	-	-	-	-	-	-	-	-	-	-	-	-	15

- The necessary mass to lower the hook refers "Lowerable Hook Mass" on page 9.
- The rated total load when the operation being performed with the rear post support pendant attached is the value remaining when the value in chart below is deducted from the rated total load chart.

Boom Length (m)	24	30	36	42	48	54	60	66	72
Equivalent Mass (ton)	0.3	0.5	0.7	0.8	0.9	1.2	1.4	1.6	1.7

■ Main Boom (Rear end Radius: Short)



Unit: ton

Working Radius(m)	Boom Length (m)									Working Radius(m)
	24	30	36	42	48	54	60	66	72	
5.9	180.0	6.5m x 180.0t								5.9
6	180.0	180.0t	7.2m x 180.0t	7.9m x 170.0t						6
7	180.0	180.0	180.0t	170.0t	8.6m x 157.0t					7
8	180.0	180.0	180.0	170.0	157.0	9.3m x 131.0t	9.9m x 118.0t			8
9	180.0	180.0	180.0	170.0	157.0	131.0t	118.0t	10.6m x 104.0t	11.3m x 100.0t	9
10	180.0	180.0	176.9	170.0	157.0	131.0	118.0	104.0t	100.0t	10
12	146.3	143.0	140.4	138.4	136.5	131.0	118.0	104.0	100.0	12
14	120.3	117.7	115.5	113.8	112.1	110.5	105.5	104.0	97.6	14
16	101.3	99.3	97.4	95.9	94.4	92.9	91.0	89.8	84.8	16
18	86.7	85.3	83.7	82.4	80.9	79.5	78.2	77.1	74.2	18
20	75.1	74.2	72.9	71.7	70.4	69.0	67.7	66.7	65.5	20
22	65.4	65.2	64.1	63.1	61.8	60.6	59.3	58.3	57.1	22
24	23.0m x 60.2t	57.7	56.9	56.0	54.8	53.6	52.4	51.4	50.2	24
26		51.2	50.7	50.0	48.9	47.8	46.6	45.6	44.5	26
28		45.5	45.5	44.9	43.9	42.8	41.6	40.7	39.6	28
30		28.2m x 45.0t	40.8	40.5	39.5	38.5	37.4	36.5	35.4	30
32			36.7	36.6	35.7	34.7	33.7	32.8	31.7	32
34			33.4m x 34.1t	33.1	32.4	31.4	30.4	29.6	28.5	34
36				30.0	29.4	28.5	27.5	26.7	25.6	36
38				27.1	26.7	25.9	24.9	24.1	23.1	38
40				38.6m x 26.3t	24.2	23.5	22.6	21.8	20.8	40
42					22.0	21.3	20.5	19.7	18.7	42
44					43.8m x 20.1t	19.3	18.5	17.8	16.8	44
46						17.5	16.7	16.1	15.1	46
48						15.8	15.1	14.5	13.5	48
50						49.0m x 14.9t	13.6	13.0	12.1	50
52							12.1	11.6	10.7	52
54							10.8	10.3	9.4	54
56							54.2m x 10.6t	9.1	8.3	56
58								7.9	7.2	58
60								59.4m x 7.2t	6.1	60
62									5.1	62
64									62.2m x 5.0t	64
66										66

- The rated loads are determined according to EN13000 rating on the condition that the machine is stationed on firm, level ground.
- To calculate the maximum load that can actually be lifted, deduct mass of all lifting accessories, such as hook, from figures shown above.
- The figures surrounded by bold lines are based on factors other than those which would cause a tipping condition.
- Working radius is the horizontal distance from the swing center to the center of gravity of a lifted load.
- The 145 ton counter weight and 25 ton lower weight are required for all capacities on these charts.
- Figures described as OOm x OOt in the tables indicate "working radius" m x "rated load" ton.
- Correlation between the number of reeved lines, maximum rated loads, hook mass are shown in the table below.

Hook Capacity	Hook Mass(ton)	Maximum Rated Load (ton)												
		13falls	12falls	11falls	10falls	9falls	8falls	7falls	6falls	5falls	4falls	3falls	2falls	1fall
180t	3.34	180	170	157	144	131	118	104	90	76	61	-	-	-
100t	3.11	-	-	-	-	-	-	100	90	76	61	46	31	-
45t	2.17	-	-	-	-	-	-	-	-	-	-	45	31	-
15t	0.62	-	-	-	-	-	-	-	-	-	-	-	-	15

- The necessary mass to lower the hook refers "Lowerable Hook Mass" on page 9.
- The rated total load when the operation being performed with the rear post support pendant attached is the value remaining when the value in chart below is deducted from the rated total load chart.

Boom Length (m)	24	30	36	42	48	54	60	66	72
Equivalent Mass (ton)	0.3	0.5	0.7	0.8	0.9	1.2	1.4	1.6	1.7

■ Aux. Sheave (Rear end Radius: Short)



Unit: ton

Working Radius(m)	Boom Length (m)									Working Radius(m)
	24	30	36	42	48	54	60	66	72	
7.5	15.0	8.2m x	8.9m x							7.5
8	15.0	15.0t	15.0t	9.5m x						8
9	15.0	15.0	15.0	15.0t	10.2m x	10.9m x	11.6m x			9
10	15.0	15.0	15.0	15.0	15.0t	15.0t	15.0t	12.3m x	12.9m x	10
12	15.0	15.0	15.0	15.0	15.0	15.0	15.0	15.0t	15.0t	12
14	15.0	15.0	15.0	15.0	15.0	15.0	15.0	15.0	15.0	14
16	15.0	15.0	15.0	15.0	15.0	15.0	15.0	15.0	15.0	16
18	15.0	15.0	15.0	15.0	15.0	15.0	15.0	15.0	15.0	18
20	15.0	15.0	15.0	15.0	15.0	15.0	15.0	15.0	15.0	20
22	15.0	15.0	15.0	15.0	15.0	15.0	15.0	15.0	15.0	22
24	15.0	15.0	15.0	15.0	15.0	15.0	15.0	15.0	15.0	24
26	24.9m x	15.0	15.0	15.0	15.0	15.0	15.0	15.0	15.0	26
28	15.0t	15.0	15.0	15.0	15.0	15.0	15.0	15.0	15.0	28
30		15.0	15.0	15.0	15.0	15.0	15.0	15.0	15.0	30
32		30.1m x	15.0	15.0	15.0	15.0	15.0	15.0	15.0	32
34		15.0t	15.0	15.0	15.0	15.0	15.0	15.0	15.0	34
36			35.3m x	15.0	15.0	15.0	15.0	15.0	15.0	36
38			15.0t	15.0	15.0	15.0	15.0	15.0	15.0	38
40				15.0	15.0	15.0	15.0	15.0	15.0	40
42				40.5m x	15.0	15.0	15.0	15.0	15.0	42
44				15.0t	15.0	15.0	15.0	15.0	15.0	44
46					45.6m x	15.0	15.0	15.0	15.0	46
48					15.0t	15.0	15.0	14.5	13.6	48
50						14.2	13.6	13.0	12.1	50
52						50.8m x	12.1	11.6	10.7	52
54						13.6t	10.8	10.3	9.4	54
56							9.5	9.1	8.2	56
58								7.9	7.1	58
60								6.8	6.0	60
62								61.2m x	5.0	62
64								6.1t		64

1. The rated loads are determined according to EN13000 rating on the condition that the machine is stationed on firm, level ground.
2. To calculate the maximum load that can actually be lifted, deduct mass of all lifting accessories, such as boom hook and jib hook, from figures shown above.
3. The figures surrounded by bold lines are based on factors other than those which would cause a tipping condition.
4. Working radius is the horizontal distance from the swing center to the center of gravity of a lifted load.
5. The 145 ton counter weight and 25 ton lower weight are required for all capacities on these charts.
6. Figures described as OOm x OOt in the tables indicate "working radius" m x "rated load" ton.
7. Hook mass are shown in the table below.

Hook Capacity	Hook Mass(ton)
180t	3.34
100t	3.11
45t	2.17
15t	0.62

8. The rated total load when the operation being performed with the rear post support pendant attached is the value remaining when the value in chart below is deducted from the rated total load chart.

Boom Length (m)	24	30	36	42	48	54	60	66	72
Equivalent Mass (ton)	0.3	0.5	0.7	0.8	0.9	1.2	1.4	1.6	1.7

■ Main Boom with Aux. Sheave (Rear end Radius: Short)



Unit: ton

Working Radius(m)	Boom Length (m)									Working Radius(m)
	24	30	36	42	48	54	60	66	72	
5.9	180.0	6.5m x								5.9
6	180.0	180.0t	7.2m x	7.9m x						6
7	180.0	180.0	180.0t	170.0t	8.6m x					7
8	180.0	180.0	180.0	170.0	157.0t	9.3m x	9.9m x			8
9	180.0	180.0	180.0	170.0	157.0	131.0t	118.0t	10.6m x	11.3m x	9
10	180.0	178.8	175.5	170.0	157.0	131.0	118.0	104.0t	100.0t	10
12	145.1	141.8	139.1	137.1	135.1	131.0	118.0	104.0	100.0	12
14	119.1	116.6	114.3	112.6	110.8	109.2	104.3	102.9	96.1	14
16	100.2	98.2	96.3	94.8	93.1	91.6	89.9	88.5	83.6	16
18	85.7	84.2	82.6	81.2	79.7	78.3	76.9	75.8	73.0	18
20	74.0	73.2	71.8	70.6	69.2	67.8	66.5	65.4	64.2	20
22	64.4	64.2	63.0	62.0	60.7	59.4	58.1	57.1	55.8	22
24	23.0m x	56.7	55.8	54.9	53.7	52.5	51.2	50.2	49.0	24
26	59.3t	50.2	49.7	49.0	47.8	46.6	45.4	44.4	43.3	26
28		44.6	44.5	43.9	42.8	41.7	40.5	39.5	38.4	28
30		28.2m x	39.9	39.5	38.5	37.4	36.3	35.3	34.2	30
32		44.0t	35.8	35.6	34.7	33.7	32.6	31.7	30.5	32
34			33.4m x	32.1	31.4	30.4	29.3	28.4	27.3	34
36			33.1t	29.1	28.4	27.5	26.4	25.6	24.5	36
38				26.2	25.7	24.8	23.8	23.0	21.9	38
40				38.6m x	23.3	22.5	21.5	20.7	19.6	40
42				25.4t	21.0	20.3	19.4	18.6	17.6	42
44					43.8m x	18.4	17.5	16.7	15.7	44
46					19.1t	16.5	15.7	15.0	14.0	46
48						14.8	14.1	13.4	12.4	48
50						49.0m x	12.6	11.9	11.0	50
52						14.0t	11.2	10.6	9.6	52
54							9.8	9.3	8.4	54
56							54.2m x	8.1	7.2	56
58							9.7t	7.0	6.1	58
60								59.4m x	5.1	60
62								6.2t	60.2m x	62
64									5.0t	64

- The rated loads are determined according to EN13000 rating on the condition that the machine is stationed on firm, level ground.
- To calculate the maximum load that can actually be lifted, deduct mass of all lifting accessories, such as hook, from figures shown above.
- The figures surrounded by bold lines are based on factors other than those which would cause a tipping condition.
- Working radius is the horizontal distance from the swing center to the center of gravity of a lifted load.
- The 145 ton counter weight and 25 ton lower weight are required for all capacities on these charts.
- Figures described as OOm x OOt in the tables indicate "working radius" m x "rated load" ton.
- Correlation between the number of reeved lines, maximum rated loads, hook mass are shown in the table below.

Hook Capacity	Hook Mass(ton)	Maximum Rated Load (ton)												
		13falls	12falls	11falls	10falls	9falls	8falls	7falls	6falls	5falls	4falls	3falls	2falls	1fall
180t	3.34	180	170	157	144	131	118	104	90	76	61	-	-	-
100t	3.11	-	-	-	-	-	-	100	90	76	61	46	31	-
45t	2.17	-	-	-	-	-	-	-	-	-	-	45	31	-
15t	0.62	-	-	-	-	-	-	-	-	-	-	-	-	15

- The necessary mass to lower the hook refers "Lowerable Hook Mass" on page 9.
- The rated total load when the operation being performed with the rear post support pendant attached is the value remaining when the value in chart below is deducted from the rated total load chart.

Boom Length (m)	24	30	36	42	48	54	60	66	72
Equivalent Mass (ton)	0.3	0.5	0.7	0.8	0.9	1.2	1.4	1.6	1.7

# Tower Specifications

## Dimensions and Specifications

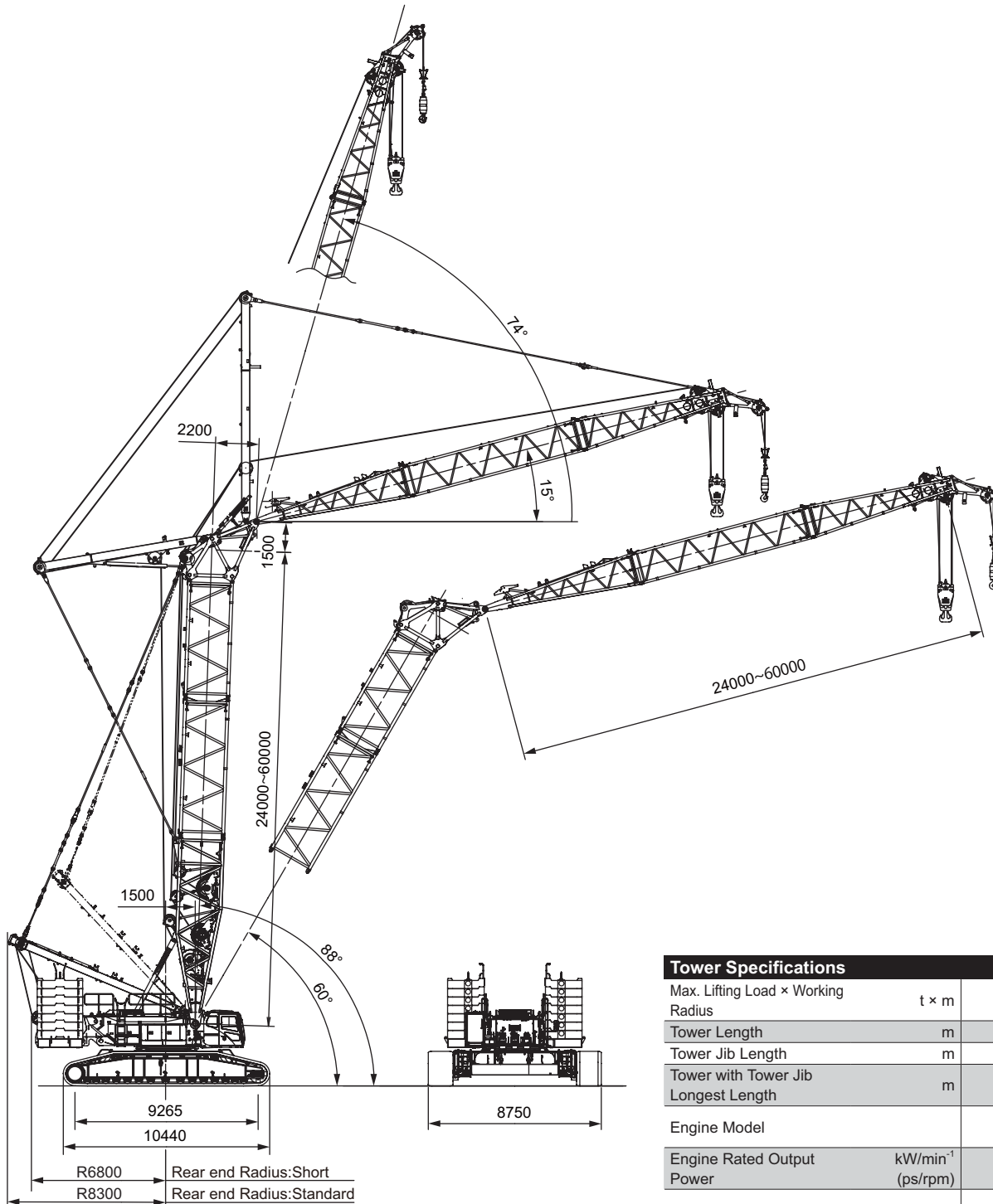

### Tower Specifications

Max. Lifting Load × Working Radius	t × m	100 × 12.4
Tower Length	m	24 to 60
Tower Jib Length	m	24 to 60
Tower with Tower Jib Longest Length	m	60 + 60
Engine Model		CUMMINS QSL9 (Stage IV/Tier 4f)
Engine Rated Output Power	kW/min <sup>-1</sup> (ps/rpm)	272/2,000 (370/2,000)
Ground Contact Pressure	kPa (kgf/cm <sup>2</sup> )	152.6 (1.55) (Tower with Tower Jib Longest Length)
Overall Operating Weight	t	Approximately 360 (Tower with Tower Jib Longest Length)

NOTE : Data is expressed in SI units followed by conventional units in ( ).

# Tower Standard Configurations

Tower Boom	
Tower Boom Length (m)	Tower Boom Configurations
24	
30	
36	
42	
48	
54	
60	

Tower Jib	
Tower Jib Length (m)	Tower Jib Configurations
24	
30	
36	
42	
48	
54	
60	

NOTE: Check the pendant rope with referring to the imprints on the rope end.

Symbols	Length (m)	Rope Diameter (mm)	Imprint
6	5.6	48	□ • △ • 48 • 5.6 • 6
9	8.6	48	□ • △ • 48 • 8.6 • 6

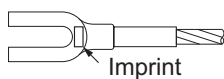

Dimensions Not Shown In The Figure		
Symbols	Tower Boom Length (m)	Note
HB9.5	9.5	Boom Base
HH1.5	1.5	Hammer Head
HT1.5	1.5	Boom Top
H6	6	Boom Insert
H6B	6	Boom Insert B
H9	9	Boom Insert
HR7	7	Reducer

Dimensions Not Shown In The Figure		
Symbols	Tower Jib Length (m)	Note
LB8	8	Tower/Luffing Jib Base
L6	6	Tower/Luffing Jib Insert
L9	9	Tower/Luffing Jib Insert
LT7	7	Tower/Luffing Jib Top

Dimensions Not Shown In The Figure		
Symbols	Bar Pendant Length (m)	Note
2.5	2.5	0.5m + 0.3m + 1.3m (Spreader) + 0.4m
3	3	0.4m + 1.2m + 1.0m + 0.4m * For rear end radius: short radius not use
6	6	5.6m + 0.4m (Link)
7	7	6.6m + 0.4m (Link)
9	9	8.6m + 0.4m (Link)
3.1	3.1	0.4m (Link) + 2.3m + 0.4m (Link)

Dimensions Not Shown In The Figure		
Symbols	Pendant Rope Length (m)	Note
6	6	5.6m + 0.4m (Link)
9	9	8.6m + 0.4m (Link)
6.4	6.4	0.45m (Link) + 5.6m (Bar Pendant) + 0.35m (Link)

**Tower Jib Installable Tower Length (Rear end Radius: Standard)**

Jib Length (m)	Tower Length						
	24	30	36	42	48	54	60
24	○	○	○	○	○	○	×
30	○	○	○	○	○	○	○
36	○	○	○	○	○	○	○
42	○	○	○	○	○	○	○
48	○	○	○	○	○	○	○
54	○	○	○	○	○	○	△
60	○	○	○	○	○	○	△

The symbols in the table are as below.

○ : Attachable

× : Not Attachable

△ : Removal of Sheave Lock Required

**Tower Jib Installable Tower Length (Rear end Radius: Short)**

Jib Length (m)	Tower Length						
	24	30	36	42	48	54	60
24	○	○	○	○	○	×	×
30	○	○	○	○	○	○	×
36	○	○	○	○	○	○	×
42	○	○	○	○	○	○	×
48	○	○	○	○	○	○	×
54	○	○	○	○	○	△	×
60	○	○	○	○	○	△	×

The symbols in the table are as below.

○ : Attachable

× : Not Attachable

△ : Removal of Sheave Lock Required

## Restriction of Hook Usage

The usable hook when lifting tower jib is the following table. Using the unusable hook cause the jib to swing.

Tower Length	24							30						
	24	30	36	42	48	54	60	24	30	36	42	48	54	60
Jib Length	○	○	○	○	○	○	○	○	○	○	○	○	○	○
100t Hook	○	○	○	○	○	○	○	○	○	○	○	○	○	○
45t Hook	○	○	○	○	○	○	○	○	○	○	○	○	○	○
15t Hook	×	×	×	○	○	○	○	×	×	×	○	○	○	○

Tower Length	36							42						
	24	30	36	42	48	54	60	24	30	36	42	48	54	60
Jib Length	○	○	○	○	○	○	○	○	○	○	○	○	○	○
100t Hook	○	○	○	○	○	○	○	○	○	○	○	○	○	○
45t Hook	○	○	○	○	○	○	○	○	○	○	○	○	○	○
15t Hook	×	×	×	○	○	○	○	×	×	×	○	○	○	○

Tower Length	48							54						
	24	30	36	42	48	54	60	24	30	36	42	48	54	60
Jib Length	○	○	○	○	○	○	○	○	○	○	○	○	○	○
100t Hook	○	○	○	○	○	○	○	○	○	○	○	○	○	○
45t Hook	×	○	○	○	○	○	○	×	○	○	○	○	○	○
15t Hook	×	×	×	○	○	○	○	×	×	×	○	○	○	○

Tower Length	60					
	30	36	42	48	54	60
Jib Length	○	○	○	○	○	○
100t Hook	○	○	○	○	○	○
45t Hook	×	○	○	○	○	○
15t Hook	×	×	○	○	○	○

The symbols in the table are as below.

○ : usable

× : unusable



## Lowerable Hook Mass

Unit:ton

Tower Length + Jib Length (m)	No. of Reeved Lines						
	1 fall	2 falls	3 falls	4 falls	5 falls	6 falls	7 falls
48	0.6	2.1	2.1	3.1	3.1	3.1	3.1
54	0.6	2.1	2.1	3.1	3.1	3.1	3.1
60	0.6	2.1	2.1	3.1	3.1	3.1	3.1
66	0.6	2.1	2.1	3.1	3.1	3.1	3.1
72	0.6	2.1	2.1	3.1	3.1	3.1	-
78	0.6	2.1	2.1	3.1	3.1	-	-
84	0.6	2.1	2.1	3.1	3.1	-	-
90	0.6	2.1	2.1	3.1	-	-	-
96	0.7	2.1	2.1	3.1	-	-	-
102	0.7	2.1	2.1	-	-	-	-
108	0.7	2.1	2.1	-	-	-	-
114	0.8	2.1	2.2	-	-	-	-
120	0.8	2.1	-	-	-	-	-

# Working Ranges

## ■Rear end Radius: Standard

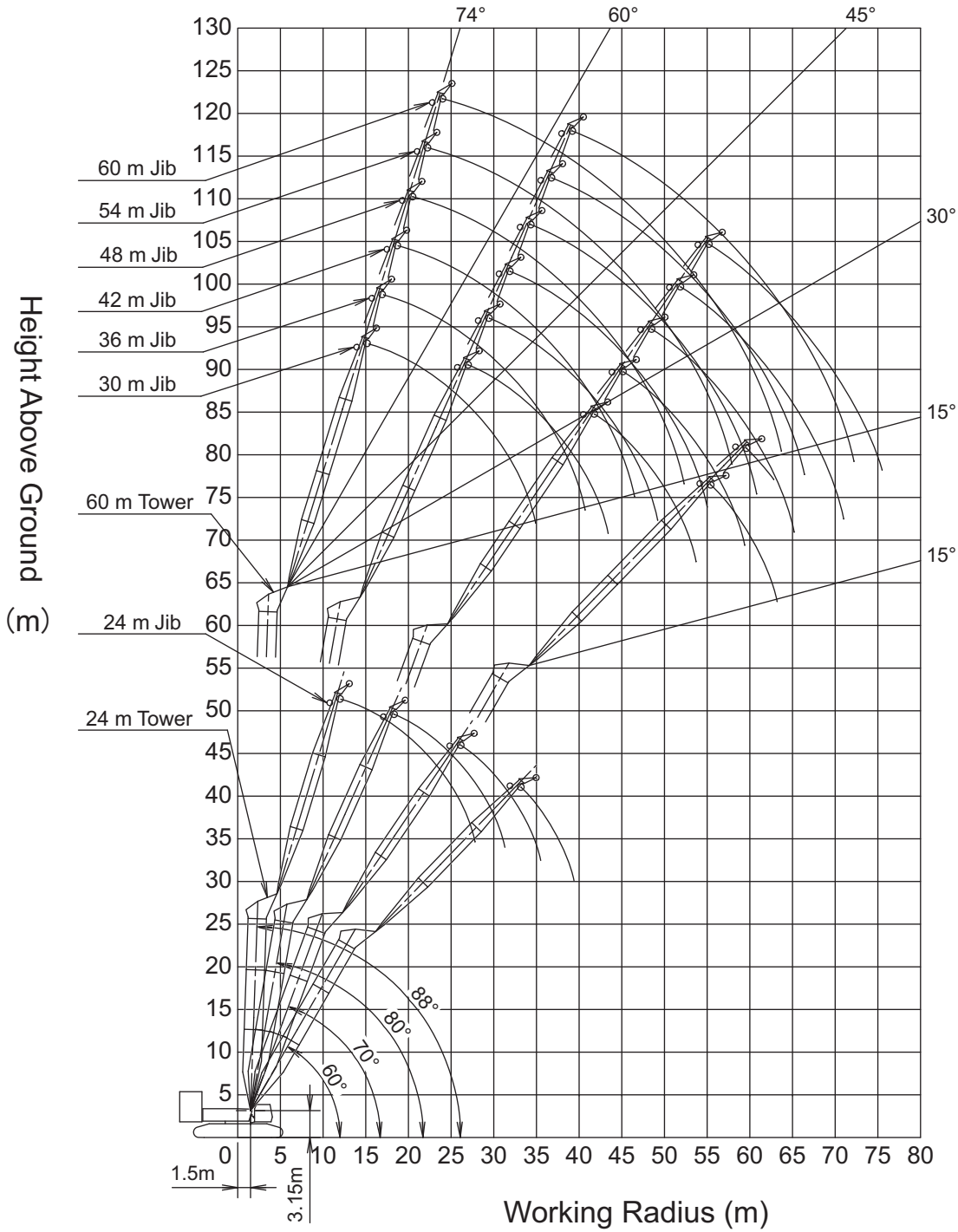
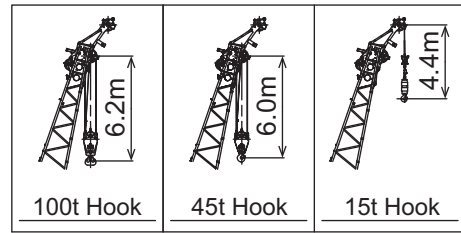

■ Rear end Radius: Short

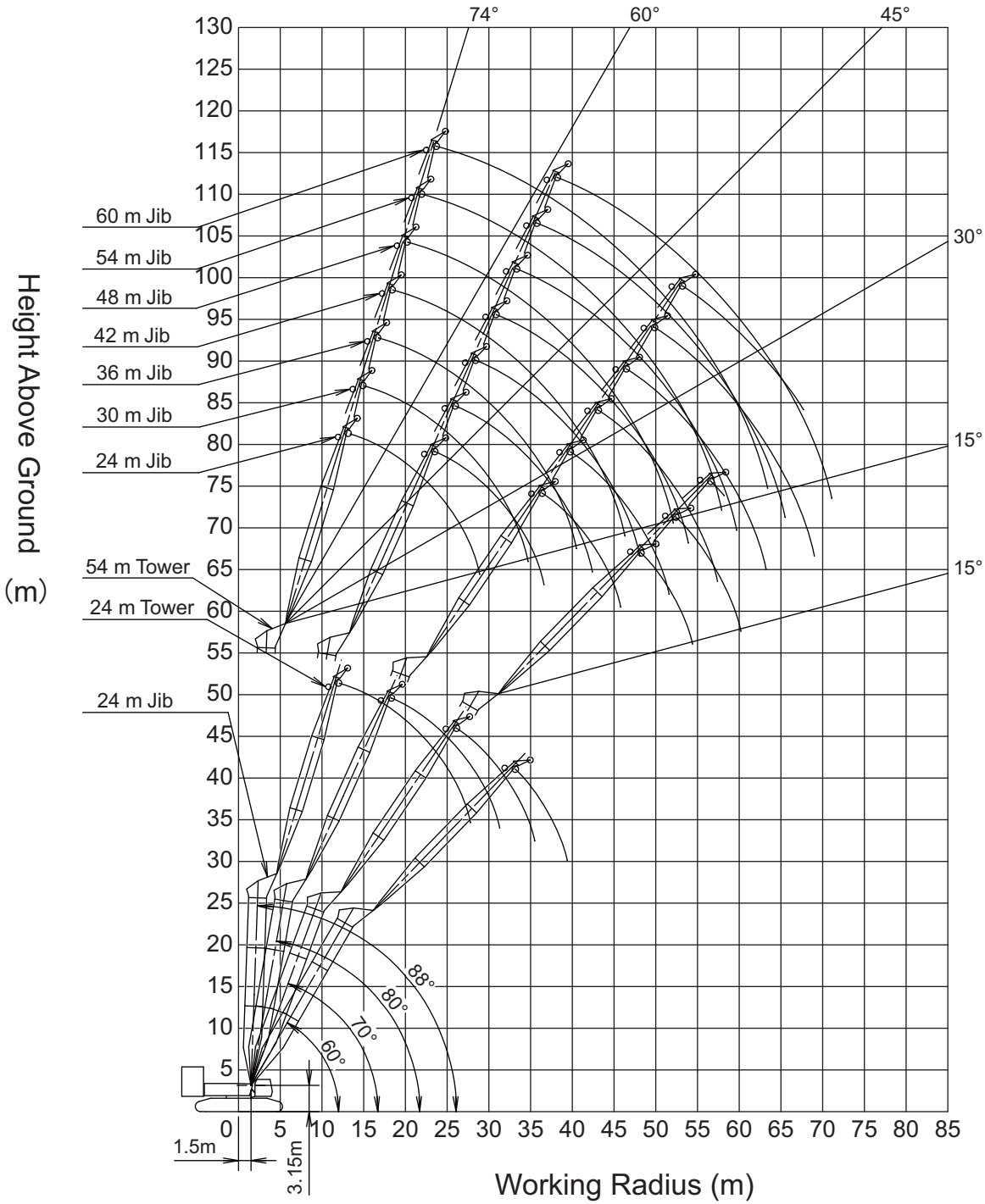
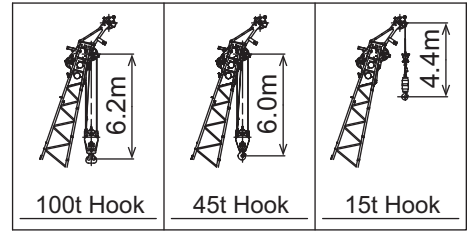

# Gross Rated Load Table

## ■ Tower 24 m (Rear end Radius: Standard)



Unit: ton

Boom Length (m)	24								Boom Length (m)
Jib Length (m)	24				30				Jib Length (m)
Boom Angle (deg.)	88	80	70	60	88	80	70	60	Boom Angle (deg.)
Radius (m)									Radius (m)
-					13.8m x 90.0t				-
12.1	100.0				89.2				12.1
14	93.0				82.2				14
16	84.1	18.3m x			75.0	20.8m x			16
18	76.9	85.8t			69.1	74.4t			18
20	70.9	79.6			64.0	71.1			20
22	65.9	73.1			59.7	65.9			22
24	58.6	67.2	26.1m x		56.0	60.6	29.5m x		24
26	45.5	60.6	55.9t		52.9	55.1	47.6t		26
28	27.8m x	55.0	51.1		44.1	50.4	46.6		28
30	33.7t	48.2	46.7	33.2m x	34.8	46.4	42.9		30
32		31.3m x	42.9	37.8t	33.6m x	42.9	39.6	37.4m x	32
34		38.8t	39.6	36.6	27.3t	37.5	36.8	32.2t	34
36			35.5m x	33.9		37.1m x	34.3	31.5	36
38			37.4t	31.6		31.6t	32.0	29.4	38
40				39.4m x			41.3m x	27.6	40
42				30.0t			30.7t	25.9	42
44								45.2m x	44
46								25.0t	46
48									48

Unit: ton

Boom Length (m)	24								Boom Length (m)
Jib Length (m)	36				42				Jib Length (m)
Boom Angle (deg.)	88	80	70	60	88	80	70	60	Boom Angle (deg.)
Radius (m)									Radius (m)
12	15.5m x				17.2m x				12
14	79.1t				69.9t				14
16	77.5				67.9				16
18	71.9				63.3				18
20	66.8	23.2m x			59.2	25.7m x			20
22	61.8	64.4t			55.5	56.1t			22
24	57.5	62.7			51.9	55.6			24
26	53.8	58.9			48.7	52.3			26
28	50.6	54.6			45.9	49.3			28
30	47.8	49.9	32.9m x		43.4	45.3			30
32	45.3	45.9	40.7t		41.2	41.8	36.2m x		32
34	40.2	42.4	38.9		39.2	38.8	35.2t		34
36	33.2	39.3	36.1		36.3	36.1	33.0		36
38	26.7	36.7	33.6	41.6m x	30.8	33.7	30.8		38
40	39.4m x	34.3	31.4	27.2t	25.7	31.6	28.8	45.7m x	40
42	21.9t	29.1	29.4	26.8	20.9	29.6	27.0	23.2t	42
44		42.9m x	27.6	25.2	45.2m x	27.9	25.4	23.0	44
46		25.7t	26.0	23.7	17.8t	23.1	23.9	21.6	46
48			47.1m x	22.3		48.7m x	22.6	20.4	48
50			25.2t	21.1		21.1t	21.4	19.2	50
52				51.0m x			52.9m x	18.2	52
54				20.5t			20.8t	17.2	54
56								56.8m x	56
58								16.9t	58
60									60

- The rated loads are determined according to EN13000 rating on the condition that the machine is stationed on firm, level ground.
- To calculate the maximum load that can actually be lifted, deduct mass of all lifting accessories, such as hook, from figures shown above.
- The figures surrounded by bold lines are based on factors other than those which would cause a tipping condition.
- Working radius is the horizontal distance from the swing center to the center of gravity of a lifted load.
- The 145 ton counter weight and 25 ton lower weight are required for all capacities on these charts.
- Figures described as OOm x OOt in the tables indicate "working radius" m x "rated load" ton.
- The usable hook when lifting tower jib is described on page 23. Using the unusable hook cause the jib to swing.
- Correlation between the number of reeved lines, maximum rated loads, hook mass are shown in the table below.

Hook Capacity	Hook Mass(ton)	Maximum Rated Load (ton)						
		7falls	6falls	5falls	4falls	3falls	2falls	1fall
100t	3.11	100	90	76	61	46	31	-
45t	2.17	-	-	-	-	45	31	-
15t	0.62	-	-	-	-	-	-	15

- The necessary mass to lower the hook refers "Lowerable Hook Mass" on page 25.
- Be sure to attach the balance weight (420kg x 2) to the top jib when the jib length is 24m.
- Remove the sheave block the boom top when using jib length 54 or 60 m for boom length 60 m.
- The gross rated load value of the jib with the sheave block the boom top is after 1.1 tons is deducted from the gross rated load of the jib.

■ Tower 24 m (Rear end Radius: Standard)



Unit: ton

Boom Length (m)		24								Boom Length (m)	
Jib Length (m)		48				54				Jib Length (m)	
Boom Angle (deg.)		88	80	70	60	88	80	70	60	Boom Angle (deg.)	
Radius (m)		Radius (m)									
16	18.9m x										16
18	62.4t					20.6m x					18
20	60.1					55.4t					20
22	56.3					52.8					22
24	52.9					49.4					24
26	49.7					46.3					26
28	47.0	28.1m x				43.6	30.5m x				28
30	44.5	49.4t				41.1	43.6t				30
32	42.0	46.8				38.9	41.8				32
34	39.7	41.2				36.9	39.7				34
36	37.7	38.2	39.6m x			35.1	37.7				36
38	35.9	35.5	30.5t			33.5	35.0				38
40	34.3	33.1	30.1			32.0	32.6	42.9m x			40
42	32.5	31.0	28.1			30.6	30.5	26.7t			42
44	28.1	29.1	26.4			29.4	28.6	25.8			44
46	24.0	27.3	24.8	49.9m x		28.2	26.8	24.2			46
48	20.2	25.8	23.3	19.8t		25.6	25.2	22.7			48
50	16.5	24.3	22.0	19.7		22.2	23.8	21.4			50
52	51.0m x	22.8	20.7	18.6	19.1	22.5	20.1	54.1m x			52
54	14.5t	18.5	19.6	17.6	16.1	21.3	19.0	16.9t			54
56		54.5m x	18.6	16.6	13.1	20.1	18.0	16.0			56
58		17.4t	17.7	15.7	56.8m x	18.4	17.0	15.1			58
60			58.7m x	14.9	11.8t	14.9	16.1	14.3			60
62			17.3t	14.2		60.3m x	15.3	13.5			62
64				62.6m x		14.4t	14.6	12.8			64
66				14.0t			64.5m x	12.1			66
68							14.4t	11.5			68
70								68.4m x			70
72								11.4t			72

Unit: ton

Boom Length (m)		24				Boom Length (m)	
Jib Length (m)		60				Jib Length (m)	
Boom Angle (deg.)		88	80	70	60	Boom Angle (deg.)	
Radius (m)		Radius (m)					
20	22.4m x						20
22	40.8t						22
24	38.6						24
26	36.2						26
28	33.9						28
30	31.9	33.0m x					30
32	30.1	32.4t					32
34	28.5	31.5					34
36	27.0	29.7					36
38	25.6	28.2					38
40	24.3	26.7					40
42	23.2	25.4					42
44	22.1	24.1	46.3m x				44
46	21.1	23.0	23.4t				46
48	20.2	22.0	22.1				48
50	19.4	21.0	20.8				50
52	18.6	20.1	19.6				52
54	17.9	19.3	18.5				54
56	17.3	18.6	17.4	58.2m x			56
58	15.2	17.9	16.5	14.4t			58
60	12.8	17.3	15.6	13.6			60
62	10.3	16.7	14.7	12.9			62
64	62.6m x	14.9	14.0	12.2			64
66	9.5t	12.0	13.2	11.5			66
68		66.1m x	12.6	10.9			68
70		11.8t	11.9	10.3			70
72			70.3m x	9.7			72
74			11.9t	9.2			74
76				74.2m x			76
78				9.2t			78

\* For notes about the table above, refer to page 28.

■ Tower 30 m (Rear end Radius: Standard)



Unit: ton

Boom Length (m)	30								Boom Length (m)
Jib Length (m)	24				30				Jib Length (m)
Boom Angle (deg.)	88	80	70	60	88	80	70	60	Boom Angle (deg.)
Radius (m)									Radius (m)
10	12.4m x								10
12	100.0t				14.1m x				12
14	94.7				89.3t				14
16	86.9	19.4m x			82.9				16
18	80.4	85.2t			76.7	21.8m x			18
20	75.0	82.2			71.4	74.1t			20
22	70.5	73.5			66.9	73.3			22
24	62.1	66.2			63.0	66.1			24
26	48.5	59.7	28.2m x		59.7	59.7			26
28	35.2	54.2	48.7t		56.8	54.2	31.6m x		28
30	28.1m x	49.5	44.9		47.6	49.6	41.8t		30
32	34.4t	43.0	41.2		38.3	45.6	41.1		32
34		32.4m x	38.1	36.2m x	33.8m x	42.2	38.0		34
36		39.8t	35.3	31.5t	29.7t	39.2	35.3		36
38			37.6m x	29.5		35.1	32.8	40.4m x	38
40			33.3t	27.5		38.2m x	30.7	27.0t	40
42				25.7		33.9t	28.7	25.6	42
44				42.4m x			43.4m x	24.0	44
46				25.4t			27.5t	22.6	46
48								21.3	48
50								48.2m x	50
52								21.2t	52

Unit: ton

Boom Length (m)	30								Boom Length (m)
Jib Length (m)	36				42				Jib Length (m)
Boom Angle (deg.)	88	80	70	60	88	80	70	60	Boom Angle (deg.)
Radius (m)									Radius (m)
12	15.8m x								12
14	78.7t				17.5m x				14
16	78.1				69.6t				16
18	72.6				68.4				18
20	67.6				63.9				20
22	63.2	24.3m x			59.9				22
24	59.4	64.4t			56.2	26.7m x			24
26	56.1	59.1			53.0	56.5t			26
28	53.2	53.6			50.2	53.1			28
30	50.7	49.0			47.7	48.4			30
32	47.9	45.1	34.9m x		45.4	44.5			32
34	44.5	41.6	36.0t		43.5	41.1			34
36	37.3	38.6	34.6		40.9	38.1	38.3m x		36
38	30.5	36.0	32.2		38.2	35.4	31.1t		38
40	39.6m x	33.6	30.0		35.4	33.1	29.3		40
42	24.8t	31.5	28.1	44.6m x	29.9	30.9	27.4		42
44		28.6	26.3	22.8t	24.7	29.0	25.7		44
46			24.8	21.9	45.4m x	27.3	24.1	48.7m x	46
48			23.4	20.6	20.8t	25.8	22.7	19.4t	48
50			49.2m x	19.4		49.8m x	21.4	18.7	50
52			22.6t	18.3		24.3t	20.3	17.6	52
54				17.4			19.2	16.6	54
56							55.0m x	15.7	56
58							18.7t	14.9	58
60								59.8m x	60
62								14.2t	62

\* For notes about the table above, refer to page 28.

■ **Tower 30 m (Rear end Radius: Standard)**



		30									
Boom Length (m)		30								Boom Length (m)	
Jib Length (m)		48				54				Jib Length (m)	
Boom Angle (deg.)										Boom Angle (deg.)	
Radius (m)		88	80	70	60	88	80	70	60	Radius (m)	
16	19.2m x									16	
18	62.1t					20.9m x				18	
20	60.5					55.2t				20	
22	56.8					53.1				22	
24	53.4					49.6				24	
26	50.3					46.5				26	
28	47.6	29.1m x				43.8	31.6m x			28	
30	45.1	49.8t				41.3	43.8t			30	
32	42.9	47.8				39.1	43.4			32	
34	40.9	43.9				37.0	39.9			34	
36	39.2	40.5				35.2	36.9			36	
38	37.5	37.5				33.6	34.3			38	
40	35.1	34.8	41.6m x			32.0	31.9			40	
42	33.0	32.5	27.1t			30.7	29.8	45.0m x		42	
44	31.0	30.4	26.8			29.4	27.9	23.7t		44	
46	28.7	28.5	25.0			28.2	26.2	22.9		46	
48	24.4	26.8	23.5			26.8	24.7	21.5		48	
50	19.9	25.2	22.1			25.2	23.3	20.2		50	
52	51.2m x	23.8	20.8	52.9m x		23.3	21.9	19.0		52	
54	17.1t	22.5	19.6	16.5t		19.7	20.8	17.9	57.1m x	54	
56		21.3	18.5	16.0		16.0	19.7	16.9	13.9t	56	
58		55.6m x	17.6	15.1		57.0m x	18.6	16.0	13.6	58	
60		20.4t	16.6	14.2		14.1t	17.7	15.2	12.8	60	
62			15.8	13.5						62	
64			60.8m x	12.8			61.4m x	14.4	12.1	64	
66			15.5t	12.1			17.1t	13.6	11.4	66	
68				65.6m x				13.0	10.8	68	
70				11.6t				66.6m x	10.2	70	
72								12.8t	9.7	72	
74									71.4m x	74	
									9.3t		74

		30					
Boom Length (m)		30				Boom Length (m)	
Jib Length (m)		60				Jib Length (m)	
Boom Angle (deg.)						Boom Angle (deg.)	
Radius (m)		88	80	70	60	Radius (m)	
20	22.6m x					20	
22	40.7t					22	
24	38.8					24	
26	36.3					26	
28	34.1					28	
30	32.1					30	
32	30.2					32	
34	28.6		32.4			34	
36	27.0		30.5			36	
38	25.7		28.9			38	
40	24.4		27.4			40	
42	23.2		26.0			42	
44	22.1		24.7			44	
46	21.2		23.5	48.3m x		46	
48	20.2		22.4	20.7t		48	
50	19.4		21.4	19.6		50	
52	18.6		20.5	18.5		52	
54	17.9		19.7	17.4		54	
56	17.3		18.9	16.4		56	
58	16.7		18.1	15.5	61.2m x	58	
60	15.9		17.2	14.6	11.7t	60	
62	12.9		16.3	13.8	11.5	62	
64	62.8m x		15.5	13.1	10.8	64	
66	11.6t		14.7	12.4	10.2	66	
68			67.2m x	11.7	9.6	68	
70			14.3t	11.1	9.0	70	
72				10.5	8.5	72	
74				72.4m x	8.0	74	
76				10.4t	7.6	76	
78					77.2m x	78	
80					7.3t	80	

\* For notes about the table above, refer to page 28.

■ Tower 36 m (Rear end Radius: Standard)



Boom Length (m)		36								Boom Length (m)	
Jib Length (m)		24				30				Jib Length (m)	
Boom Angle (deg.)		88	80	70	60	88	80	70	60	Boom Angle (deg.)	
Radius (m)		Radius (m)									
10	12.7m x										10
12	98.3t					14.4m x					12
14	93.2					86.8t					14
16	86.1					81.8					16
18	79.9		20.4m x			76.2					18
20	74.5		78.2t			71.2		22.9m x			20
22	69.9		71.5			66.9		68.0t			22
24	64.7		64.4			63.3		64.3			24
26	50.8		58.5			59.7		58.4			26
28	37.4		53.2	30.3m x		56.4		53.2			28
30	28.3m x		48.6	42.4t		49.5		48.7	33.6m x		30
32	35.2t		44.7	39.4		40.0		44.7	36.8t		32
34			33.4m x	36.3		30.4		41.4	36.2		34
36			40.9t	33.7	39.2m x	34.1m x		38.4	33.6		36
38				31.3	26.0t	29.8t		35.8	31.2		38
40				39.6m x	25.3			39.2m x	29.1	43.4m x	40
42				29.6t	23.7			34.3t	27.3	22.4t	42
44					22.1				25.6	22.0	44
46					45.4m x				45.4m x	20.6	46
48					21.2t				24.6t	19.4	48
50										18.3	50
52										51.2m x	52
54										17.7t	54

Boom Length (m)		36								Boom Length (m)	
Jib Length (m)		36				42				Jib Length (m)	
Boom Angle (deg.)		88	80	70	60	88	80	70	60	Boom Angle (deg.)	
Radius (m)		Radius (m)									
14	16.1m x					17.8m x					14
16	76.5t					67.8t					16
18	71.7					67.4					18
20	67.2					63.3					20
22	63.1		25.3m x			59.5					22
24	59.5		59.6t			56.1		27.7m x			24
26	56.4		57.7			53.1		52.7t			26
28	53.6		52.6			50.4		52.0			28
30	51.2		48.1			48.0		47.5			30
32	47.4		44.2			45.9		43.6			32
34	44.0		40.8	37.0m x		43.5		40.2			34
36	38.8		37.8	31.7t		40.4		37.3			36
38	31.9		35.2	30.5		37.8		34.6	40.3m x		38
40	39.9m x		32.9	28.5		35.4		32.3	27.5t		40
42	25.0t		30.8	26.6		31.2		30.2	25.9		42
44			28.9	24.9	47.6m x	25.8		28.4	24.3		44
46			45.0m x	23.4	18.9t	45.6m x		26.7	22.8		46
48			28.1t	22.1	18.7	21.3t		25.2	21.4	51.7m x	48
50				20.8	17.6			23.8	20.2	16.0t	50
52				51.2m x	16.6			50.8m x	19.1	15.8	52
54				20.2t	15.6			23.2t	18.0	14.9	54
56					14.8				17.1	14.1	56
58					57.0m x				57.0m x	13.3	58
60					14.4t				16.6t	12.6	60
62										11.9	62
64										62.8m x	64
66										11.7t	66

\* For notes about the table above, refer to page 28.



■ **Tower 36 m (Rear end Radius: Standard)**



Unit: ton

Boom Length (m)	36								Boom Length (m)
Jib Length (m)	48				54				Jib Length (m)
Boom Angle (deg.)	88	80	70	60	88	80	70	60	Boom Angle (deg.)
Radius (m)	88	80	70	60	88	80	70	60	Radius (m)
16	19.5m x								16
18	60.6t				21.2m x				18
20	59.7				52.7t				20
22	56.2				52.3				22
24	53.1				49.9				24
26	50.2				46.7				26
28	47.6	30.2m x			43.9				28
30	45.3	46.4t			41.4	32.6m x			30
32	43.2	43.0			39.2	41.4t			32
34	41.3	39.6			37.1	39.1			34
36	39.6	36.6			35.3	36.1			36
38	37.1	34.0			33.6	33.5			38
40	34.7	31.7			32.1	31.2			40
42	32.6	29.6	43.7m x		30.7	29.1			42
44	30.6	27.8	23.8t		29.4	27.3	47.0m x		44
46	28.8	26.1	23.6		28.3	25.6	20.8t		46
48	25.4	24.6	22.1		26.7	24.0	20.2		48
50	21.2	23.2	20.8		25.2	22.6	18.9		50
52	51.4m x	21.9	19.5		23.7	21.4	17.8		52
54	18.0t	20.7	18.4	55.9m x	20.9	20.2	16.8		54
56		19.7	17.4	13.4t	17.4	19.1	15.8		56
58		56.6m x	16.4	13.4	57.2m x	18.1	14.9	60.1m x	58
60		19.4t	15.5	12.6	15.2t	17.2	14.1	11.2t	60
62			14.7	11.9			13.3	10.5	62
64			14.0	11.2			16.3	12.6	64
66			62.8m x	10.6		62.4m x	12.0	9.9	66
68			13.7t	10.0		16.2t	11.4	8.8	68
70				9.5			68.6m x	8.3	70
72				68.6m x			11.2t	7.8	72
74				9.4t				7.4	74
76								74.4m x	76
78								7.3t	78

Unit: ton

Boom Length (m)	36				Boom Length (m)
Jib Length (m)	60				Jib Length (m)
Boom Angle (deg.)	88	80	70	60	Boom Angle (deg.)
Radius (m)	88	80	70	60	Radius (m)
20	22.9m x				20
22	40.5t				22
24	39.0				24
26	36.5				26
28	34.3				28
30	32.2				30
32	30.3	35.1m x			32
34	28.7	32.2t			34
36	27.1	31.4			36
38	25.7	29.7			38
40	24.4	28.1			40
42	23.3	26.6			42
44	22.2	25.3			44
46	21.2	24.1			46
48	20.3	22.9	50.4m x		48
50	19.4	21.9	18.1t		50
52	18.6	20.9	17.2		52
54	17.9	19.7	16.2		54
56	17.3	18.6	15.2		56
58	16.7	17.6	14.3		58
60	16.2	16.7	13.5		60
62	14.3	15.8	12.8	64.2m x	62
64	63.0m x	15.0	12.0	9.2t	64
66	12.7t	14.2	11.4	8.7	66
68		13.5	10.8	8.2	68
70		68.2m x	10.2	7.7	70
72		13.5t	9.6	7.2	72
74			9.1	6.7	74
76			74.4m x	6.3	76
78			9.0t	5.8	78
80				5.5	80
82				80.2m x	82
84				5.4t	84

\* For notes about the table above, refer to page 28.

■ Tower 42 m (Rear end Radius: Standard)



Unit: ton

Boom Length (m)	42								Boom Length (m)
Jib Length (m)	24				30				Jib Length (m)
Boom Angle (deg.)	88	80	70	60	88	80	70	60	Boom Angle (deg.)
Radius (m)									Radius (m)
10	12.9m x								10
12	92.3t				14.6m x				12
14	88.6				81.8t				14
16	82.3				78.0				16
18	76.9	21.5m x			73.0				18
20	72.3	71.4t			68.5	23.9m x			20
22	68.4	69.5			64.7	63.0t			22
24	65.3	62.6			61.3	62.7			24
26	52.7	56.9			58.5	57.0			26
28	39.3	52.0			56.0	52.1			28
30	28.5m x	47.6	32.3m x		51.1	47.8			30
32	35.6t	43.8	37.0t		41.5	44.0	35.7m x		32
34		40.4	34.5		31.9	40.6	32.4t		34
36		34.5m x	32.0		34.3m x	37.7	32.0		36
38		39.6t	29.7		30.3t	35.1	29.8		38
40			27.7	42.2m x		32.8	27.8		40
42			41.7m x	21.4t		40.3m x	26.0		42
44			26.1t	20.1		32.5t	24.4	46.4m x	44
46				18.8			22.9	18.6t	46
48				17.7			47.5m x	17.7	48
50				48.4m x			21.9t	16.6	50
52				17.4t				15.7	52
54								14.8	54
56								54.2m x	56
58								14.7t	58

Unit: ton

Boom Length (m)	42								Boom Length (m)
Jib Length (m)	36				42				Jib Length (m)
Boom Angle (deg.)	88	80	70	60	88	80	70	60	Boom Angle (deg.)
Radius (m)									Radius (m)
14	16.3m x								14
16	72.3t								16
18	68.5				64.1				18
20	64.4				60.5				20
22	60.7				57.1				22
24	57.4	26.3m x			54.0				24
26	54.6	55.2t			51.2	28.8m x			26
28	52.1	51.1			48.8	48.7t			28
30	49.9	46.9			46.6	46.2			30
32	46.9	43.2			44.6	42.6			32
34	43.5	39.9			42.9	39.3			34
36	40.0	37.0	39.0m x		40.0	36.4			36
38	33.0	34.4	27.8t		37.3	33.8			38
40	25.7	32.1	26.9		35.0	31.5	42.4m x		40
42	40.1m x	30.1	25.1		32.1	29.5	24.1t		42
44	25.3t	28.2	23.5		26.7	27.7	22.8		44
46		26.6	22.1		45.9m x	26.0	21.4		46
48		46.1m x	20.7	50.6m x	21.3t	24.5	20.1		48
50		26.5t	19.6	15.4t		23.1	18.9		50
52			18.5	14.8		51.9m x	17.8	54.7m x	52
54			53.3m x	13.9		21.9t	16.8	12.9t	54
56			17.8t	13.1			15.9	12.4	56
58				12.4			15.0	11.7	58
60				11.7			59.1m x	11.0	60
62							14.6t	10.4	62
64								9.8	64
66								65.8m x	66
68								9.3t	68

\* For notes about the table above, refer to page 28.

■ **Tower 42 m (Rear end Radius: Standard)**



		42								Unit: ton	
Boom Length (m)									Boom Length (m)		
Jib Length (m)	48				54				Jib Length (m)		
Boom Angle (deg.)									Boom Angle (deg.)		
Radius (m)	88	80	70	60	88	80	70	60	Radius (m)		
16	19.7m x								16		
18	54.9t				21.4m x				18		
20	54.8				46.8t				20		
22	53.6				46.5				22		
24	50.9				45.6				24		
26	48.3				44.7				26		
28	45.9	31.2m x			43.0				28		
30	43.8	43.6t			41.0	33.7m x			30		
32	41.9	42.2			39.2	38.5t			32		
34	40.2	38.9			37.3	38.1			34		
36	38.6	36.0			35.4	35.2			36		
38	37.0	33.5			33.7	32.7			38		
40	34.6	31.2			32.2	30.4			40		
42	32.5	29.1	45.7m x		30.7	28.4			42		
44	30.5	27.3	21.1t		29.5	26.5			44		
46	28.7	25.6	20.9		27.9	24.9	49.1m x		46		
48	26.3	24.1	19.6		26.3	23.4	18.1t		48		
50	22.0	22.7	18.4		24.9	22.0	17.6		50		
52	51.7m x	21.5	17.4		23.5	20.7	16.5		52		
54	18.2t	20.3	16.4		21.5	19.6	15.5		54		
56		19.3	15.4	58.9m x	18.0	18.5	14.6		56		
58		57.7m x	14.6	10.8t	57.4m x	17.5	13.8		58		
60		18.4t	13.8	10.5	15.4t	16.6	13.0	63.1m x	60		
62			13.1	9.8		15.8	12.3	8.5t	62		
64			12.4	9.2		63.5m x	11.6	8.2	64		
66			64.9m x	8.7		15.2t	10.9	7.7	66		
68			12.1t	8.2			10.4	7.1	68		
70				7.7			9.8	6.7	70		
72				71.6m x			70.7m x	6.2	72		
74				7.3t			9.6t	5.8	74		
76								5.4	76		
78								77.4m x	78		
80								5.2t	80		

		42			Unit: ton	
Boom Length (m)				Boom Length (m)		
Jib Length (m)	60			Jib Length (m)		
Boom Angle (deg.)				Boom Angle (deg.)		
Radius (m)	88	80	70	Radius (m)		
20	23.1m x			20		
22	39.7t			22		
24	39.2			24		
26	36.7			26		
28	34.4			28		
30	32.3			30		
32	30.5			32		
34	28.8	36.1m x		34		
36	27.2	32.2t		36		
38	25.8	30.5		38		
40	24.5	28.8		40		
42	23.3	27.3		42		
44	22.2	25.9		44		
46	21.2	24.4		46		
48	20.3	22.9		48		
50	19.4	21.5	52.4m x	50		
52	18.7	20.3	15.7t	52		
54	17.9	19.1	15.0	54		
56	17.3	18.0	14.0	56		
58	16.7	17.0	13.2	58		
60	16.1	16.1	12.4	60		
62	14.8	15.3	11.6	62		
64	63.2m x	14.5	10.9	64		
66	13.0t	13.7	10.3	66		
68		13.0	9.7	68		
70		69.2m x	9.1	70		
72		12.6t	8.6	72		
74			8.1	74		
76			7.6	76		
78			76.5m x	78		
80			7.5t	80		

\* For notes about the table above, refer to page 28.

■ Tower 48 m (Rear end Radius: Standard)



Unit: ton

Boom Length (m)		48								Boom Length (m)	
Jib Length (m)		24				30				Jib Length (m)	
Boom Angle (deg.)		88	80	70	60	88	80	70	60	Boom Angle (deg.)	
Radius (m)		Radius (m)									
10	13.2m x										10
12	83.7t					14.9m x					12
14	81.5					74.6t					14
16	76.1					72.0					16
18	71.3					67.7					18
20	67.2					63.7					20
22	63.8	22.5m x				60.2	24.9m x				22
24	60.9	65.8t				57.2	58.1t				24
26	54.4	60.9				54.7	55.1				26
28	41.1	55.3				52.5	50.4				28
30	28.7m x	41.1				50.6	46.3				30
32	36.0t	46.4				42.7	42.8				32
34		42.8	34.4m x			33.2	39.7				34
36		39.6	32.1t			34.5m x	36.8	37.7m x			36
38		35.5m x	30.3			30.6t	34.3	28.2t			38
40		37.4t	28.1				32.0	27.9			40
42			26.1				41.3m x	26.0			42
44			24.4	45.2m x			30.7t	24.3			44
46			43.8m x	17.3t				22.8			46
48			23.0t	16.8				21.4	49.4m x		48
50				15.7				20.1	14.8t		50
52				14.7				49.5m x	14.5		52
54				51.4m x				19.2t	13.7		54
56				14.1t					12.9		56
58									12.1		58
60									57.2m x		60
									11.7t		60

Unit: ton

Boom Length (m)		48								Boom Length (m)	
Jib Length (m)		36				42				Jib Length (m)	
Boom Angle (deg.)		88	80	70	60	88	80	70	60	Boom Angle (deg.)	
Radius (m)		Radius (m)									
14	16.6m x										14
16	64.5t					18.3m x					16
18	63.3					55.2t					18
20	59.7					54.1					20
22	56.4					52.8					22
24	53.5	27.4m x				50.1					24
26	51.0	51.0t				47.6	29.8m x				26
28	48.7	49.7				45.4	45.3t				28
30	46.7	45.6				43.5	44.9				30
32	45.0	42.1				41.7	41.4				32
34	43.4	39.0				40.2	38.4				34
36	40.4	36.2				38.8	35.6				36
38	34.0	33.7	41.1m x			37.2	33.2				38
40	26.8	31.5	24.4t			34.9	30.9				40
42	40.3m x	29.4	23.6			32.7	28.9	44.4m x			42
44	25.6t	27.6	22.1			27.6	27.1	21.1t			44
46		26.0	20.7			21.9	25.5	20.0			46
48		47.1m x	19.5			46.1m x	24.0	18.8			48
50		25.2t	18.3	53.6m x		21.6t	22.6	17.7			50
52			17.3	12.1t			21.4	16.6			52
54			16.3	12.0			52.9m x	15.7	57.7m x		54
56			55.3m x	11.3			20.9t	14.8	9.9t		56
58			15.7t	10.6				14.0	9.8		58
60				10.0				13.2	9.1		60
62				9.4				61.1m x	8.6		62
64				63.0m x				12.8t	8.0		64
66				9.1t					7.5		66
68									7.0		68
70									68.8m x		70
72									6.9t		72

\* For notes about the table above, refer to page 28.

■ Tower 48 m (Rear end Radius: Standard)



								Unit: ton
Boom Length (m)	48						Boom Length (m)	
Jib Length (m)	48			54			Jib Length (m)	
Boom Angle (deg.)	88	80	70	60	88	80	70	Boom Angle (deg.)
Radius (m)							Radius (m)	
18					21.7m x			18
20	47.7				41.0t			20
22	46.6				40.9			22
24	45.6				40.1			24
26	44.6				39.3			26
28	42.6				38.5			28
30	40.7	32.3m x			37.7			30
32	39.0	40.2t			36.3	34.7m x		32
34	37.4	37.6			34.8	36.0t		34
36	36.0	34.9			33.4	34.3		36
38	34.8	32.5			32.2	31.9		38
40	33.6	30.3			31.1	29.7		40
42	32.1	28.3			30.0	27.8		42
44	30.2	26.5	47.8m x		29.1	26.0		44
46	28.4	24.9	18.1t		27.9	24.4		46
48	26.8	23.4	18.0		26.3	22.9	51.1m x	48
50	22.7	22.1	16.9		24.8	21.6	15.6t	50
52	51.9m x	20.8	15.8		23.5	20.3	15.2	52
54	18.3t	19.7	14.9		22.2	19.2	14.2	54
56		18.6	14.0		18.7	18.1	13.4	56
58		17.7	13.2	61.9m x	57.7m x	17.2	12.5	58
60		58.7m x	12.5	7.7t	15.5t	16.3	11.8	60
62		17.4t	11.8	7.7		15.4	11.1	62
64			11.1	7.2		14.6	10.4	64
66			10.5	6.7		64.5m x	9.8	66
68			66.9m x	6.2		14.5t	9.2	68
70			10.3t	5.8			8.7	70
72				5.4			8.2	72
74				5.0			72.7m x	74
76				74.2m x			8.0t	76
78				5.0t				78

				Unit: ton
Boom Length (m)	48			Boom Length (m)
Jib Length (m)	60			Jib Length (m)
Boom Angle (deg.)	88	80	70	Boom Angle (deg.)
Radius (m)				Radius (m)
20	23.4m x			20
22	35.6t			22
24	35.4			24
26	34.7			26
28	34.1			28
30	32.5			30
32	30.6			32
34	28.9	37.1m x		34
36	27.3	32.0t		36
38	25.9	30.9		38
40	24.6	28.8		40
42	23.4	26.8		42
44	22.3	25.1		44
46	21.3	23.5		46
48	20.3	22.1		48
50	19.5	20.7		50
52	18.7	19.5	54.5m x	52
54	17.9	18.4	13.0t	54
56	17.3	17.3	12.4	56
58	16.7	16.3	11.6	58
60	16.1	15.4	10.8	60
62	15.3	14.6	10.1	62
64	63.5m x	13.8	9.5	64
66	13.0t	13.1	8.9	66
68		12.4	8.3	68
70		11.7	7.8	70
72		70.3m x	7.3	72
74		11.7t	6.8	74
76			6.3	76
78			5.9	78
80			78.5m x	80
82			5.8t	82

\* For notes about the table above, refer to page 28.

■ Tower 54 m (Rear end Radius: Standard)



Unit: ton

Boom Length (m)	54								Boom Length (m)
Jib Length (m)	24				30				Jib Length (m)
Boom Angle (deg.)	88	80	70	60	88	80	70	60	Boom Angle (deg.)
Radius (m)									Radius (m)
10	13.4m x								10
12	72.4t				15.1m x				12
14	71.6				62.8t				14
16	68.4				61.9				16
18	64.1				60.0				18
20	60.5	23.5m x			57.4				20
22	57.4	60.7t			54.3				22
24	54.7	59.2			51.7				24
26	52.6	53.7			49.3	53.5			26
28	42.7	49.1			47.3	48.9			28
30	28.9m x	45.1			45.6	44.9			30
32	36.3t	41.6			43.9	41.5			32
34		38.5	36.4m x		34.4	38.5			34
36		35.8	27.6t		34.7m x	35.8	39.8m x		36
38		36.6m x	26.1		30.8t	33.4	24.2t		38
40		35.0t	24.3			31.3	24.1		40
42			22.7			29.3	22.5		42
44			21.3			42.4m x	21.1		44
46			45.8m x	48.2m x		28.9t	19.8		46
48			20.0t	13.2t			18.6		48
50				12.4			17.6	52.4m x	50
52				11.6			51.6m x	11.2t	52
54				10.9			16.8t	10.6	54
56				54.4m x				10.0	56
58				10.7t				9.4	58
60								8.8	60
62								60.2m x	62
64								8.7t	64

Unit: ton

Boom Length (m)	54								Boom Length (m)
Jib Length (m)	36				42				Jib Length (m)
Boom Angle (deg.)	88	80	70	60	88	80	70	60	Boom Angle (deg.)
Radius (m)									Radius (m)
14	16.8m x								14
16	54.4t				18.5m x				16
18	53.5				47.2t				18
20	52.0				46.3				20
22	50.6				45.1				22
24	48.2				44.0				24
26	45.9	28.4m x			42.8				26
28	43.9	47.4t			40.8	30.9m x			28
30	42.1	44.3			39.1	41.7t			30
32	40.5	40.8			37.5	39.8			32
34	39.1	37.8			36.0	36.8			34
36	37.9	35.2			34.8	34.2			36
38	34.9	32.8			33.6	31.9			38
40	27.8	30.7	43.1m x		32.7	29.8			40
42	40.5m x	28.8	20.9t		31.9	27.9			42
44	25.8t	27.0	20.3		28.2	26.1	46.5m x		44
46		25.4	19.0		22.7	24.6	17.7t		46
48		23.9	17.9		46.3m x	23.1	16.8		48
50		48.1m x	16.8		21.7t	21.8	15.8		50
52		23.9t	15.8			20.6	14.8		52
54			14.9	56.6m x		53.9m x	13.9		54
56			14.1	8.9t		19.6t	13.1		56
58			57.4m x	8.5			12.3	60.7m x	58
60			13.5t	8.0			11.6	6.7t	60
62				7.4			11.0	6.4	62
64				7.0			63.2m x	5.9	64
66				6.5			10.6t	5.4	66
68								5.0	68
70								68.2m x	70
72								5.0t	72

\* For notes about the table above, refer to page 28.

■ **Tower 54 m (Rear end Radius: Standard)**



Unit: ton

Boom Length (m)	54						Boom Length (m)
Jib Length (m)	48			54			Jib Length (m)
Boom Angle (deg.)	88	80	70	88	80	70	Boom Angle (deg.)
Radius (m)							Radius (m)
18	20.3m x						18
20	40.9t						20
22	40.2			35.9			22
24	39.3			35.1			24
26	38.4			34.4			26
28	37.5			33.7			28
30	36.4	33.3m x		33.0			30
32	34.9	37.0t		32.3	35.7m x		32
34	33.5	36.4		31.0	32.4t		34
36	32.2	33.8		29.8	32.2		36
38	31.1	31.5		28.6	30.5		38
40	30.1	29.4		27.6	28.4		40
42	29.2	27.5		26.7	26.5		42
44	28.4	25.8		25.8	24.8		44
46	27.7	24.2	49.8m x	25.1	23.3		46
48	26.8	22.8	15.4t	24.4	21.9		48
50	23.3	21.5	15.3	23.8	20.6	53.2m x	50
52	18.8	20.3	14.3	23.2	19.4	12.8t	52
54	52.1m x	19.1	13.4	22.0	18.3	12.4	54
56	18.5t	18.1	12.6	19.2	17.2	11.6	56
58		17.2	11.9	57.9m x	16.3	10.9	58
60		59.7m x	11.2	15.6t	15.4	10.2	60
62		16.4t	10.5		14.6	9.5	62
64			9.9		13.8	8.9	64
66			9.3		65.5m x	8.3	66
68			8.7		13.3t	7.8	68
70			69.0m x			7.3	70
72			8.5t			6.8	72
74						6.4	74
76						74.8m x	76
78						6.2t	78

Unit: ton

Boom Length (m)	54			Boom Length (m)
Jib Length (m)	60			Jib Length (m)
Boom Angle (deg.)	88	80	70	Boom Angle (deg.)
Radius (m)				Radius (m)
20	23.7m x			20
22	31.0t			22
24	31.0			24
26	30.6			26
28	30.0			28
30	29.4			30
32	28.9			32
34	28.3			34
36	26.9	38.2m x		36
38	25.5	28.1t		38
40	24.3	27.1		40
42	23.1	26.0		42
44	22.0	24.3		44
46	21.1	22.8		46
48	20.2	21.4		48
50	19.3	20.0		50
52	18.5	18.9		52
54	17.8	17.7	56.5m x	54
56	17.2	16.7	10.8t	56
58	16.6	15.8	10.2	58
60	16.0	14.9	9.5	60
62	15.5	14.0	8.9	62
64	63.4m x	13.3	8.3	64
66	13.3t	12.5	7.7	66
68		11.9	7.2	68
70		11.2	6.7	70
72		71.1m x	6.2	72
74		10.9t	5.7	74
76			5.3	76
78			77.5m x	78
80			5.0t	80

\* For notes about the table above, refer to page 28.

■ Tower 60 m (Rear end Radius: Standard)



Unit: ton

Boom Length (m)	60								Boom Length (m)
Jib Length (m)	30				36				Jib Length (m)
Boom Angle (deg.)	88	80	70	60	88	80	70	60	Boom Angle (deg.)
Radius (m)									Radius (m)
12	15.4m x								12
14	52.6t				17.1m x				14
16	52.1				45.8t				16
18	50.4				45.2				18
20	48.8				43.9				20
22	47.3				42.6				22
24	45.2	27.0m x			41.4				24
26	43.1	46.6t			40.1	29.5m x			26
28	41.2	45.5			38.3	40.4t			28
30	39.6	43.3			36.6	40.0			30
32	38.2	40.2			35.1	38.2			32
34	35.5	37.3			33.8	36.3			34
36	34.9m x	34.7			32.7	33.7			36
38	31.0t	32.3	41.8m x		31.7	31.4			38
40		30.3	20.6t		28.6	29.4			40
42		28.4	20.5		40.7m x	27.5	45.2m x		42
44		43.4m x	19.2		26.0t	25.8	17.4t		44
46		27.2t	18.0			24.3	16.9		46
48			16.9			22.9	15.8		48
50			15.9			49.2m x	14.8		50
52			14.9	55.4m x		22.1t	13.9		52
54			53.7m x	7.9t			13.1		54
56			14.2t	7.8			12.3	59.6m x	56
58				7.2			11.6	5.7t	58
60				6.7			59.4m x	5.6	60
62				6.2			11.1t	5.2	62
64				63.2m x				62.8m x	64
66				6.0t				5.0t	66

Boom Length (m)	60						Boom Length (m)
Jib Length (m)	42			48			Jib Length (m)
Boom Angle (deg.)	88	80	70	88	80	70	Boom Angle (deg.)
Radius (m)							Radius (m)
16	18.8m x						16
18	40.2t			20.5m x			18
20	39.6			35.3t			20
22	38.6			34.7			22
24	37.5			33.9			24
26	36.6			33.0			26
28	35.5	31.9m x		32.3			28
30	33.9	35.2t		31.5			30
32	32.5	35.2		30.2	34.3m x		32
34	31.2	33.6		28.9	30.7t		34
36	30.0	32.2		27.8	29.6		36
38	29.0	30.8		26.7	28.4		38
40	28.0	28.8		25.8	27.1		40
42	27.2	26.9		24.9	25.9		42
44	26.6	25.3		24.1	24.5		44
46	23.4	23.7	48.5m x	23.5	23.0		46
48	46.5m x	22.4	14.8t	22.9	21.7	51.9m x	48
50	21.9t	21.1	14.1	22.3	20.4	12.4t	50
52		19.9	13.2	19.3	19.2	12.4	52
54		18.8	12.4	52.3m x	18.2	11.6	54
56		55.0m x	11.6	18.6t	17.2	10.8	56
58		18.3t	10.9		16.2	10.1	58
60			10.2		15.4	9.5	60
62			9.6		60.8m x	8.9	62
64			9.0		15.1t	8.3	64
66			65.2m x			7.8	66
68			8.7t			7.3	68
70						6.8	70
72						71.0m x	72
74						6.6t	74

\* For notes about the table above, refer to page 28.



■ **Tower 60 m (Rear end Radius: Standard)**



Unit: ton

Boom Length (m)	60					Boom Length (m)
Jib Length (m)	54			60		Jib Length (m)
Boom Angle (deg.)	88	80	70	88	80	Boom Angle (deg.)
Radius (m)						Radius (m)
20	22.3m x					20
22	30.9t					22
24	30.4			27.2		24
26	29.7			26.7		26
28	29.1			26.1		28
30	28.4			25.6		30
32	27.7			25.0		32
34	26.5	36.8m x		24.4		34
36	25.4	26.6t		23.3	39.2m x	36
38	24.4	25.9		22.3	22.8t	38
40	23.5	24.9		21.5	22.4	40
42	22.7	23.9		20.6	21.5	42
44	21.9	22.8		19.9	20.7	44
46	21.2	21.8		19.2	19.8	46
48	20.6	20.9		18.5	18.9	48
50	20.0	19.9		18.0	18.1	50
52	19.5	18.7	55.2m x	17.4	17.4	52
54	19.1	17.6	10.5t	17.0	16.7	54
56	18.6	16.6	10.2	16.5	15.8	56
58	57.9m x	15.7	9.5	16.2	14.8	58
60	15.7t	14.8	8.8	15.8	14.0	60
62		14.0	8.2	15.4	13.2	62
64		13.3	7.6	63.7m x	12.4	64
66		12.5	7.1	13.2t	11.7	66
68		66.4m x	6.6		11.1	68
70		12.4t	6.1		10.4	70
72			5.7		9.9	72
74			5.3		72.2m x	74
76			75.5m x		9.8t	76
78			5.0t			78

\* For notes about the table above, refer to page 28.

■ Tower 24 m (Rear end Radius: Short)



Unit: ton

Boom Length (m)	24								Boom Length (m)
Jib Length (m)	24				30				Jib Length (m)
Boom Angle (deg.)	88	80	70	60	88	80	70	60	Boom Angle (deg.)
Radius (m)									Radius (m)
-					13.8m x				-
12.1	100.0				90.0t				12.1
14	92.9				89.2				14
16	84.0	18.3m x			82.1				16
18	76.8	85.6t			74.9	20.8m x			18
20	70.8	78.1			68.9	74.3t			20
22	65.8	69.8			63.9	69.7			22
24	58.6	62.9	26.1m x		59.6	62.8			24
26	45.5	57.1	52.4t		55.9	57.1	29.5m x		26
28	27.8m x	52.3	48.1		52.8	52.3	45.0t		28
30	33.7t	48.1	44.2	33.2m x	44.1	48.1	44.1		30
32		31.3m x	40.8	35.5t	34.8	44.5	40.7		32
34		38.8t	37.8	34.5	33.6m x	41.3	37.8	37.4m x	34
36			35.5m x	32.0	27.3t	37.5	35.2	30.4t	36
38			35.8t	29.9		37.1m x	32.9	29.7	38
40				39.4m x		31.6t	30.8	27.8	40
42				28.5t			41.3m x	26.1	42
44							29.6t	24.6	44
46								45.2m x	46
48								23.7t	48

Unit: ton

Boom Length (m)	24								Boom Length (m)
Jib Length (m)	36				42				Jib Length (m)
Boom Angle (deg.)	88	80	70	60	88	80	70	60	Boom Angle (deg.)
Radius (m)									Radius (m)
12	15.5m x								12
14	79.1t				17.2m x				14
16	77.5				69.9t				16
18	71.9				67.9				18
20	66.6	23.2m x			63.3				20
22	61.7	64.4t			59.2	25.7m x			22
24	57.4	62.1			55.5	56.0t			24
26	53.7	56.4			51.9	55.5			26
28	50.5	51.5			48.7	50.8			28
30	47.7	47.4	32.9m x		45.8	46.7			30
32	44.9	43.8	38.5t		43.3	43.1			32
34	40.2	40.6	36.9		41.1	39.9	36.2m x		34
36	33.2	37.8	34.4		38.2	37.1	33.3t		36
38	26.7	35.3	32.1	41.6m x	35.7	34.6	31.3		38
40	39.4m x	33.1	30.0	25.6t	30.8	32.4	29.2		40
42	21.9t	29.1	28.1	25.3	25.7	30.4	27.4	45.7m x	42
44		42.9m x	26.5	23.7	20.9	28.6	25.7	21.7t	44
46		25.7t	25.0	22.3	45.2m x	26.9	24.2	21.5	46
48			47.1m x	21.0	17.8t	23.1	22.8	20.2	48
50			24.2t	19.9		48.7m x	21.5	19.1	50
52				51.0m x		21.1t	20.4	18.0	52
54				19.3t			52.9m x	17.0	54
56							19.9t	16.1	56
58								56.8m x	58
60								15.8t	60

- The rated loads are determined according to EN13000 rating on the condition that the machine is stationed on firm, level ground.
- To calculate the maximum load that can actually be lifted, deduct mass of all lifting accessories, such as hook, from figures shown above.
- The figures surrounded by bold lines are based on factors other than those which would cause a tipping condition.
- Working radius is the horizontal distance from the swing center to the center of gravity of a lifted load.
- The 145 ton counter weight and 25 ton lower weight are required for all capacities on these charts.
- Figures described as OOm x OOt in the tables indicate "working radius" m x "rated load" ton.
- The usable hook when lifting tower jib is described on page 23. Using the unusable hook cause the jib to swing.
- Correlation between the number of reeved lines, maximum rated loads, hook mass are shown in the table below.

Hook Capacity	Hook Mass(ton)	Maximum Rated Load (ton)						
		7falls	6falls	5falls	4falls	3falls	2falls	1fall
100t	3.11	100	90	76	61	46	31	-
45t	2.17	-	-	-	-	45	31	-
15t	0.62	-	-	-	-	-	-	15

- The necessary mass to lower the hook refers "Lowerable Hook Mass" on page 25.
- Be sure to attach the balance weight(420kg x 2) to the top jib when the jib length is 24m.
- Remove the sheave block the boom top when using jib length 54 or 60 m for boom length 54 m.
- The gross rated load value of the jib with the sheave block the boom top is after 1.1 ton is deducted from the gross rated load of the jib.

■ **Tower 24 m (Rear end Radius: Short)**



Unit: ton

Boom Length (m)	24								Boom Length (m)
Jib Length (m)	48				54				Jib Length (m)
Boom Angle (deg.)	88	80	70	60	88	80	70	60	Boom Angle (deg.)
Radius (m)									Radius (m)
16	18.9m x								16
18	62.4t				20.6m x				18
20	60.1				55.4t				20
22	56.3				52.8				22
24	52.8				49.4				24
26	49.7	28.1m x			46.3				26
28	46.9	49.3t			43.6	30.5m x			28
30	44.4	45.9			41.1	43.5t			30
32	41.9	42.3			38.9	41.7			32
34	39.7	39.2			36.9	38.6			34
36	37.6	36.4	39.6m x		35.1	35.8			36
38	35.0	33.9	28.9t		33.5	33.3			38
40	32.7	31.7	28.5		32.0	31.1	42.9m x		40
42	30.7	29.7	26.6		30.1	29.1	25.1t		42
44	28.1	27.9	25.0		28.3	27.3	24.3		44
46	24.0	26.2	23.4	49.9m x	26.6	25.6	22.7		46
48	20.2	24.8	22.1	18.3t	25.0	24.1	21.4		48
50	16.5	23.4	20.8	18.3	22.2	22.7	20.1		50
52	51.0m x	22.1	19.6	17.2	19.1	21.5	18.9	54.1m x	52
54	14.5t	18.5	18.6	16.2	16.1	20.3	17.9	15.4t	54
56		54.5m x	17.6	15.3	13.1	19.2	16.9	14.6	56
58		17.4t	16.7	14.5	56.8m x	18.2	16.0	13.7	58
60			58.7m x	13.7	11.8t	14.9	15.1	12.9	60
62			16.4t	13.0		60.3m x	14.3	12.2	62
64				62.6m x		14.4t	13.6	11.5	64
66				12.8t			64.5m x	10.9	66
68							13.4t	10.3	68
70								68.4m x	70
72								10.2t	72

Unit: ton

Boom Length (m)	24				Boom Length (m)
Jib Length (m)	60				Jib Length (m)
Boom Angle (deg.)	88	80	70	60	Boom Angle (deg.)
Radius (m)					Radius (m)
20	22.4m x				20
22	40.8t				22
24	38.6				24
26	36.2				26
28	33.9				28
30	31.9	33.0m x			30
32	30.1	32.4t			32
34	28.5	31.5			34
36	27.0	29.7			36
38	25.6	28.2			38
40	24.3	26.7			40
42	23.2	25.4			42
44	22.1	24.1	46.3m x		44
46	21.1	23.0	21.9t		46
48	20.2	22.0	20.7		48
50	19.4	21.0	19.4		50
52	18.6	20.1	18.3		52
54	17.9	19.3	17.2		54
56	17.3	18.6	16.2	58.2m x	56
58	15.2	17.6	15.3	12.9t	58
60	12.8	16.7	14.4	12.2	60
62	10.3	15.8	13.6	11.5	62
64	62.6m x	14.9	12.9	10.8	64
66	9.5t	12.0	12.2	10.2	66
68		66.1m x	11.5	9.6	68
70		11.8t	10.9	9.0	70
72			70.3m x	8.5	72
74			10.8t	8.0	74
76				74.2m x	76
78				8.0t	78

\* For notes about the table above, refer to page 42.

■ Tower 30 m (Rear end Radius: Short)



Unit: ton

Boom Length (m)	30								Boom Length (m)
Jib Length (m)	24				30				Jib Length (m)
Boom Angle (deg.)	88	80	70	60	88	80	70	60	Boom Angle (deg.)
Radius (m)									Radius (m)
10	12.4m x								10
12	100.0t				14.1m x				12
14	94.4				89.2t				14
16	86.6	19.4m x			82.6				16
18	80.1	77.3t			76.5	21.8m x			18
20	74.7	74.6			71.1	67.1t			20
22	69.1	66.6			66.6	66.4			22
24	62.1	60.0			62.4	59.9			24
26	48.5	54.5	28.2m x		56.7	54.4			26
28	35.2	49.8	44.1t		51.9	49.7	31.6m x		28
30	28.1m x	45.7	40.9		47.6	45.7	38.1t		30
32	34.4t	42.2	37.7		38.3	42.2	37.5		32
34		32.4m x	34.9	36.2m x	33.8m x	39.2	34.8		34
36		39.8t	32.4	28.3t	29.7t	36.5	32.3		36
38			37.6m x	26.6		34.1	30.2	40.4m x	38
40			30.7t	24.8		38.2m x	28.2	24.2t	40
42				23.2		33.9t	26.5	23.0	42
44				42.4m x			43.4m x	21.6	44
46				22.9t			25.4t	20.3	46
48								19.2	48
50								48.2m x	50
52								19.1t	52

Unit: ton

Boom Length (m)	30								Boom Length (m)
Jib Length (m)	36				42				Jib Length (m)
Boom Angle (deg.)	88	80	70	60	88	80	70	60	Boom Angle (deg.)
Radius (m)									Radius (m)
12	15.8m x								12
14	78.4t				17.5m x				14
16	77.8				69.3t				16
18	72.3				68.1				18
20	67.3				63.7				20
22	62.9	24.3m x			59.6				22
24	59.1	58.2t			56.0	26.7m x			24
26	55.8	53.6			52.8	51.2t			26
28	51.3	49.0			49.9	48.3			28
30	47.1	45.0			46.5	44.3			30
32	43.5	41.5	34.9m x		42.9	40.8			32
34	40.3	38.5	32.8t		39.8	37.8			34
36	37.3	35.8	31.5		37.0	35.1	38.3m x		36
38	30.5	33.4	29.4		34.5	32.7	28.3t		38
40	39.6m x	31.3	27.4		32.3	30.6	26.6		40
42	24.8t	29.4	25.7	44.6m x	29.9	28.7	24.9		42
44		27.6	24.1	20.3t	24.7	26.9	23.3		44
46			22.7	19.4	45.4m x	25.4	21.9	48.7m x	46
48			21.4	18.3	20.8t	23.9	20.6	17.1t	48
50			49.2m x	17.2		49.8m x	19.4	16.4	50
52			20.7t	16.3		22.8t	18.4	15.4	52
54				15.4			17.4	14.5	54
56							55.0m x	13.7	56
58							16.9t	12.9	58
60								59.8m x	60
62								12.3t	62

\* For notes about the table above, refer to page 42.

■ **Tower 30 m (Rear end Radius: Short)**



Unit: ton

Boom Length (m)	30								Boom Length (m)
Jib Length (m)	48				54				Jib Length (m)
Boom Angle (deg.)	88	80	70	60	88	80	70	60	Boom Angle (deg.)
Radius (m)									Radius (m)
16	19.2m x				20.9m x				16
18	61.9t				55.1t				18
20	60.3								20
22	56.5				53.1				22
24	53.2				49.6				24
26	50.1	29.1m x			46.5				26
28	47.3	45.3t			43.8	31.6m x			28
30	44.9	43.5			41.3	40.1t			30
32	42.3	40.1			39.1	39.5			32
34	39.1	37.1			37.0	36.4			34
36	36.3	34.4			35.2	33.8			36
38	33.8	32.0	41.6m x		33.3	31.4			38
40	31.6	29.9	24.4t		31.1	29.3			40
42	29.6	28.0	24.1		29.1	27.3	45.0m x		42
44	27.8	26.2	22.6		27.2	25.6	21.1t		44
46	26.2	24.7	21.2		25.6	24.0	20.4		46
48	24.4	23.2	19.9		24.1	22.6	19.1		48
50	19.9	21.9	18.7	52.9m x	22.7	21.3	18.0		50
52	51.2m x	20.7	17.6	14.2t	21.5	20.1	16.9		52
54	17.1t	19.6	16.6	13.7	19.7	18.9	15.9	57.1m x	54
56		55.6m x	15.7	12.9	16.0	17.9	15.0	11.7t	56
58		18.8t	14.8	12.1	57.0m x	17.0	14.1	11.4	58
60			14.1	11.4	14.1t	16.1	13.3	10.6	60
62			60.8m x	10.8		61.4m x	12.6	10.0	62
64			13.8t	10.2		15.5t	11.9	9.4	64
66				65.6m x			11.3	8.8	66
68				9.8t			66.6m x	8.3	68
70							11.1t	7.8	70
72								71.4m x	72
74								7.5t	74

Unit: ton

Boom Length (m)	30				Boom Length (m)
Jib Length (m)	60				Jib Length (m)
Boom Angle (deg.)	88	80	70	60	Boom Angle (deg.)
Radius (m)					Radius (m)
20	22.6m x				20
22	40.7t				22
24	38.8				24
26	36.3				26
28	34.1				28
30	32.1				30
32	30.2				32
34	28.6	32.4			34
36	27.0	30.5			36
38	25.7	28.9			38
40	24.4	27.4			40
42	23.2	26.0			42
44	22.1	24.7			44
46	21.2	23.5	48.3m x		46
48	20.2	22.0	18.3t		48
50	19.4	20.7	17.3		50
52	18.6	19.5	16.2		52
54	17.9	18.3	15.2		54
56	17.3	17.3	14.3		56
58	16.7	16.3	13.4	61.2m x	58
60	15.9	15.5	12.6	9.5t	60
62	12.9	14.6	11.9	9.3	62
64	62.8m x	13.8	11.2	8.7	64
66	11.6t	13.1	10.6	8.1	66
68		67.2m x	9.9	7.5	68
70		12.7t	9.4	7.0	70
72			8.8	6.6	72
74			72.4m x	6.1	74
76			8.7t	5.7	76
78				77.2m x	78
80				5.5t	80

\* For notes about the table above, refer to page 42.

■ Tower 36 m (Rear end Radius: Short)



Unit: ton

Boom Length (m)	36								Boom Length (m)
Jib Length (m)	24				30				Jib Length (m)
Boom Angle (deg.)	88	80	70	60	88	80	70	60	Boom Angle (deg.)
Radius (m)									Radius (m)
10	12.7m x								10
12	97.9t				14.4m x				12
14	92.8				86.4t				14
16	85.6				81.4				16
18	79.6	20.4m x			75.8				18
20	74.2	69.8t			70.8	22.9m x			20
22	67.6	63.8			66.5	60.6t			22
24	60.9	57.4			61.0	57.3			24
26	50.8	52.1			55.4	52.0			26
28	37.4	47.6	30.3m x		50.6	47.5			28
30	28.3m x	43.7	37.2t		46.6	43.6	33.6m x		30
32	35.2t	40.3	34.7		40.0	40.3	32.4t		32
34		33.4m x	32.1		30.4	37.3	31.9		34
36		38.2t	29.8	39.2m x	34.1m x	34.7	29.6		36
38			27.8	22.3t	29.8t	32.5	27.6		38
40			39.6m x	21.6		39.2m x	25.8	43.4m x	40
42			26.3t	20.2		31.2t	24.2	19.0t	42
44				18.9			22.7	18.7	44
46				45.4m x			45.4m x	17.5	46
48				18.1t			21.8t	16.5	48
50								15.5	50
52								51.2m x	52
54								15.0t	54

Unit: ton

Boom Length (m)	36								Boom Length (m)
Jib Length (m)	36				42				Jib Length (m)
Boom Angle (deg.)	88	80	70	60	88	80	70	60	Boom Angle (deg.)
Radius (m)									Radius (m)
14	16.1m x				17.8m x				14
16	76.1t				67.5t				16
18	71.4				67.1				18
20	66.8				62.9				20
22	62.7	25.3m x			59.2				22
24	59.1	53.0t			55.8	27.7m x			24
26	54.8	51.2			52.7	46.7t			26
28	50.1	46.7			49.5	46.0			28
30	46.0	42.9			45.4	42.2			30
32	42.4	39.6			41.9	38.9			32
34	39.3	36.6	37.0m x		38.8	36.0			34
36	36.6	34.0	27.7t		36.0	33.4			36
38	31.9	31.7	26.8		33.6	31.1	40.3m x		38
40	39.9m x	29.7	25.0		31.4	29.0	23.9t		40
42	25.0t	27.8	23.3		29.4	27.2	22.6		42
44		26.2	21.9	47.6m x	25.8	25.5	21.1		44
46		45.0m x	20.6	15.8t	45.6m x	24.0	19.8		46
48		25.4t	19.3	15.6	21.3t	22.6	18.6	51.7m x	48
50			18.2	14.6		21.3	17.5	13.0t	50
52			51.2m x	13.7		50.8m x	16.4	12.9	52
54			17.6t	12.9		20.9t	15.5	12.1	54
56				12.2			14.7	11.3	56
58				57.0m x			57.0m x	10.6	58
60				11.8t			14.3t	10.0	60
62								9.4	62
64								62.8m x	64
66								9.2t	66

\* For notes about the table above, refer to page 42.

■ Tower 36 m (Rear end Radius: Short)



		36									
Unit: ton										Unit: ton	
Boom Length (m)	Jib Length (m)	48				54				Boom Length (m)	Jib Length (m)
Boom Angle (deg.)	Radius (m)	88	80	70	60	88	80	70	60	Boom Angle (deg.)	Radius (m)
16	19.5m x									16	
18	60.2t					21.2m x				18	
20	59.3					52.7t				20	
22	55.9					52.3				22	
24	52.8					49.6				24	
26	49.9					46.7				26	
28	47.3		30.2m x			43.9				28	
30	44.8		41.1t			41.4	32.6m x			30	
32	41.2		38.1			39.2	36.6t			32	
34	38.1		35.2			37.1	34.6			34	
36	35.4		32.6			34.9	32.0			36	
38	32.9		30.3			32.4	29.7			38	
40	30.8		28.3	43.7m x		30.2	27.7			40	
42	28.8		26.4	20.5t		28.3	25.8			42	
44	27.0		24.8	20.3		26.5	24.2	47.0m x		44	
46	25.4		23.3	19.0		24.9	22.6	17.6t		46	
48	24.0		21.9	17.8		23.4	21.3	17.1		48	
50	21.2		20.6	16.7		22.0	20.0	16.0		50	
52	51.4m x		19.5	15.7	55.9m x	20.8	18.8	15.0		52	
54	18.0t		18.4	14.7	10.5t	19.7	17.7	14.0		54	
56			17.4	13.9	10.5	17.4	16.8	13.2		56	
58			56.6m x	13.1	9.8	57.2m x	15.8	12.4	60.1m x	58	
60			17.2t	12.4	9.2	15.2t	15.0	11.6	8.4t	60	
62				11.7	8.6		14.2	10.9	7.8	62	
64				62.8m x	8.1		62.4m x	10.3	7.3	64	
66				11.4t	7.6		14.1t	9.7	6.8	66	
68					7.1			9.2	6.3	68	
70					68.6m x			68.6m x	5.8	70	
72					7.0t			9.0t	5.4	72	
74									5.0	74	
76									74.2m x	76	
78									5.0t	78	

		36				
Unit: ton					Unit: ton	
Boom Length (m)	Jib Length (m)	60			Boom Length (m)	Jib Length (m)
Boom Angle (deg.)	Radius (m)	88	80	70	Boom Angle (deg.)	Radius (m)
20	22.9m x				20	
22	40.5t				22	
24	39.0				24	
26	36.5				26	
28	34.3				28	
30	32.2				30	
32	30.3		35.1m x		32	
34	28.7		32.2t		34	
36	27.1		31.4		36	
38	25.7		29.1		38	
40	24.4		27.1		40	
42	23.3		25.3		42	
44	22.2		23.6		44	
46	21.2		22.1		46	
48	20.3		20.7	50.4m x	48	
50	19.4		19.4	15.1t	50	
52	18.6		18.2	14.3	52	
54	17.9		17.2	13.4	54	
56	17.3		16.2	12.5	56	
58	16.7		15.2	11.7	58	
60	16.2		14.4	11.0	60	
62	14.3		13.6	10.3	62	
64			12.8	9.6	64	
66	63.0m x		12.1	9.0	66	
68	12.7t		11.5	8.4	68	
70			68.2m x	7.9	70	
72			11.4t	7.4	72	
74				7.0	74	
76				74.4m x	76	
78				6.9t	78	

\* For notes about the table above, refer to page 42.

■ Tower 42 m (Rear end Radius: Short)



Unit: ton

Boom Length (m)	42								Boom Length (m)
Jib Length (m)	24				30				Jib Length (m)
Boom Angle (deg.)	88	80	70	60	88	80	70	60	Boom Angle (deg.)
Radius (m)									Radius (m)
10	12.9m x								10
12	91.9t				14.6m x				12
14	88.2				81.4t				14
16	81.9				77.6				16
18	76.4	21.5m x			72.6				18
20	71.8	63.0t			68.1	23.9m x			20
22	66.4	61.3			64.2	55.5t			22
24	59.8	55.1			60.1	55.2			24
26	52.7	50.0			54.6	50.1			26
28	39.3	45.6			49.9	45.7			28
30	28.5m x	41.8	32.3m x		45.9	42.0			30
32	35.6t	38.6	31.6t		41.5	38.7	35.7m x		32
34		35.7	29.5		31.9	35.9	27.6t		34
36		34.5m x	27.3		34.3m x	33.4	27.3		36
38		35.0t	25.4		30.3t	31.2	25.4		38
40			23.7	42.2m x		29.2	23.7		40
42			41.7m x	17.2t		40.3m x	22.2		42
44			22.3t	16.2		28.9t	20.8	46.4m x	44
46				15.1			19.5	14.8t	46
48				14.1			47.5m x	14.1	48
50				48.4m x			18.7t	13.2	50
52				13.9t				12.4	52
54								11.7	54
56								54.2m x	56
58								11.6t	58

Boom Length (m)	42								Boom Length (m)
Jib Length (m)	36				42				Jib Length (m)
Boom Angle (deg.)	88	80	70	60	88	80	70	60	Boom Angle (deg.)
Radius (m)									Radius (m)
14	16.3m x								14
16	71.9t								16
18	68.1				63.8				18
20	64.1				60.1				20
22	60.3				56.8				22
24	57.1	26.3m x			53.6				24
26	53.8	48.4t			50.9	28.8m x			26
28	49.1	44.7			48.4	42.5t			28
30	45.1	41.0			44.5	40.3			30
32	41.6	37.8			41.0	37.1			32
34	38.5	35.0			38.0	34.3			34
36	35.8	32.5	39.0m x		35.3	31.8			36
38	33.0	30.2	23.5t		32.9	29.6			38
40	25.7	28.2	22.7		30.7	27.6	42.4m x		40
42	40.1m x	26.5	21.1		28.8	25.8	20.1t		42
44	25.3t	24.9	19.8		26.7	24.2	19.0		44
46		23.4	18.5		45.9m x	22.7	17.7		46
48		46.1m x	17.4	50.6m x	21.3t	21.4	16.6		48
50		23.3t	16.4	11.8t		20.2	15.6		50
52			15.4	11.3		51.9m x	14.6	54.7m x	52
54			53.3m x	10.6		19.1t	13.8	9.5t	54
56			14.9t	9.9			13.0	9.0	56
58				9.3			12.2	8.4	58
60				8.8			59.1m x	7.9	60
62							11.8t	7.3	62
64								6.9	64
66								65.8m x	66
68								6.5t	68

\* For notes about the table above, refer to page 42.



■ Tower 42 m (Rear end Radius: Short)



								Unit: ton		
Boom Length (m)	42						Boom Length (m)			
Jib Length (m)	48						54	Jib Length (m)		
Boom Angle (deg.)	88	80	70	60	88	80	70	Boom Angle (deg.)		
Radius (m)							Radius (m)			
16	19.7m x								16	
18	54.9t				21.4m x				18	
20	54.8				46.8t				20	
22	53.4				46.5				22	
24	50.6				45.6				24	
26	47.9				44.7				26	
28	45.6	31.2m x			42.7				28	
30	43.5	37.9t			40.7	33.7m x			30	
32	40.7	36.6			38.9	33.3t			32	
34	37.6	33.8			36.8	32.9			34	
36	34.9	31.3			34.1	30.4			36	
38	32.5	29.1			31.7	28.2			38	
40	30.4	27.1			29.6	26.2			40	
42	28.4	25.4	45.7m x		27.6	24.4			42	
44	26.7	23.7	17.4t		25.9	22.8			44	
46	25.1	22.3	17.2		24.3	21.4	49.1m x		46	
48	23.6	20.9	16.1		22.8	20.0	14.5t		48	
50	22.0	19.7	15.1		21.5	18.8	14.0		50	
52	51.7m x	18.6	14.1		20.3	17.7	13.1		52	
54	18.2t	17.5	13.2		19.1	16.7	12.2		54	
56		16.6	12.4	58.9m x	18.0	15.7	11.4		56	
58		57.7m x	11.7	7.6t	57.4m x	14.8	10.7		58	
60		15.8t	11.0	7.3	15.4t	14.0	10.0		60	
62			10.3	6.8		13.2	9.4		62	
64			9.7	6.3		63.5m x	8.8		64	
66			64.9m x	5.8		12.7t	8.2		66	
68			9.5t	5.4			7.7		68	
70				5.0			7.2		70	
72							70.7m x		72	
74							7.1t		74	

				Unit: ton			
Boom Length (m)	42			Boom Length (m)			
Jib Length (m)	60			60	Jib Length (m)		
Boom Angle (deg.)	88	80	70	88	Boom Angle (deg.)		
Radius (m)				Radius (m)			
20	23.1m x						20
22	39.7t						22
24	39.2						24
26	36.7						26
28	34.4						28
30	32.3						30
32	30.5						32
34	28.8	36.1m x					34
36	27.2	29.7t					36
38	25.8	27.6					38
40	24.5	25.7					40
42	23.3	23.9					42
44	22.2	22.3					44
46	21.2	20.8					46
48	20.3	19.5					48
50	19.4	18.3	52.4m x				50
52	18.7	17.1	12.3t				52
54	17.9	16.1	11.6				54
56	17.3	15.1	10.8				56
58	16.6	14.2	10.1				58
60	15.7	13.4	9.4				60
62	14.8	12.6	8.7				62
64	63.2m x	11.9	8.1				64
66	13.0t	11.2	7.6				66
68		10.6	7.0				68
70		69.2m x	6.5				70
72		10.3t	6.1				72
74			5.6				74
76			5.2				76
78			76.5m x				78
80			5.1t				80

\* For notes about the table above, refer to page 42.

■ Tower 48 m (Rear end Radius: Short)



Unit: ton

Boom Length (m)	48								Boom Length (m)
Jib Length (m)	24				30				Jib Length (m)
Boom Angle (deg.)	88	80	70	60	88	80	70	60	Boom Angle (deg.)
Radius (m)									Radius (m)
10	13.2m x								10
12	83.4t				14.9m x				12
14	81.2				74.3t				14
16	75.8				71.7				16
18	71.0				67.4				18
20	66.9	22.5m x			63.4				20
22	63.5	57.4t			59.9	24.9m x			22
24	59.1	53.1			56.9	50.5t			24
26	53.6	48.1			53.7	47.9			26
28	41.1	43.9			49.1	43.7			28
30	28.7m x	40.2			45.1	40.1			30
32	36.0t	37.1	34.4m x		41.6	37.0			32
34		34.3	26.5t		33.2	34.2	37.7m x		34
36		35.5m x	24.9		34.5m x	31.8	23.2t		36
38		32.4t	23.2		30.6t	29.7	22.9		38
40			21.5			27.7	21.3		40
42			20.1	45.2m x		41.3m x	19.9		42
44			43.8m x	12.8t		26.6t	18.6		44
46			18.9t	12.5			17.4	49.4m x	46
48				11.6			16.4	10.8t	48
50				10.8			49.5m x	10.5	50
52				51.4m x			15.6t	9.8	52
54				10.3t				9.2	54
56								8.6	56
58								57.2m x	58
60								8.3t	60

Unit: ton

Boom Length (m)	48								Boom Length (m)
Jib Length (m)	36				42				Jib Length (m)
Boom Angle (deg.)	88	80	70	60	88	80	70	60	Boom Angle (deg.)
Radius (m)									Radius (m)
14	16.6m x								14
16	64.5t				18.3m x				16
18	63.0				55.2t				18
20	59.5				54.1				20
22	56.2				52.6				22
24	53.2	27.4m x			49.8				24
26	50.7	44.2t			47.4	29.8m x			26
28	48.4	43.0			45.2	39.1t			28
30	44.6	39.4			43.2	38.7			30
32	41.1	36.3			40.6	35.6			32
34	38.1	33.6			37.6	32.9			34
36	35.4	31.1			34.9	30.5			36
38	33.0	29.0	41.1m x		32.5	28.4			38
40	26.8	27.1	19.7t		30.4	26.4			40
42	40.3m x	25.3	19.1		28.5	24.7	44.4m x		42
44	25.6t	23.8	17.8		26.7	23.1	16.8t		44
46		22.4	16.7		21.9	21.7	15.9		46
48		47.1m x	15.6		46.1m x	20.4	14.8		48
50		21.6t	14.6	53.6m x	21.6t	19.2	13.9		50
52			13.7	8.4t		18.1	13.0		52
54			12.9	8.3		52.9m x	12.2	57.7m x	54
56			55.3m x	7.7		17.7t	11.4	6.4t	56
58			12.4t	7.2			10.7	6.3	58
60				6.7			10.1	5.8	60
62				6.2			61.1m x	5.4	62
64				63.0m x			9.7t	63.7m x	64
66				6.0t				5.0t	66

\* For notes about the table above, refer to page 42.

■ **Tower 48 m (Rear end Radius: Short)**



Unit: ton

Boom Length (m)	48						Boom Length (m)
Jib Length (m)	48			54			Jib Length (m)
Boom Angle (deg.)	88	80	70	88	80	70	Boom Angle (deg.)
Radius (m)							Radius (m)
18				21.7m x			18
20	47.7			41.0t			20
22	46.6			40.9			22
24	45.6			40.1			24
26	44.5			39.3			26
28	42.4			38.5			28
30	40.5	32.3m x		37.7			30
32	38.7	34.4t		36.1	34.7m x		32
34	37.0	32.1		34.6	30.7t		34
36	34.3	29.7		33.2	29.2		36
38	31.9	27.6		31.5	27.0		38
40	29.8	25.7		29.3	25.1		40
42	27.9	24.0		27.4	23.4		42
44	26.1	22.4	47.8m x	25.7	21.9		44
46	24.6	21.0	14.1t	24.1	20.4		46
48	23.1	19.7	14.0	22.6	19.2	51.1m x	48
50	21.8	18.5	13.1	21.3	18.0	11.9t	50
52	51.9m x	17.5	12.2	20.1	16.9	11.5	52
54	18.3t	16.5	11.4	19.0	15.9	10.7	54
56		15.5	10.6	17.9	14.9	10.0	56
58		14.7	10.0	57.7m x	14.1	9.3	58
60		58.7m x	9.3	15.5t	13.3	8.6	60
62		14.4t	8.7		12.5	8.0	62
64			8.2		11.8	7.5	64
66			7.7		64.5m x	7.0	66
68			66.9m x		11.7t	6.5	68
70			7.4t			6.0	70
72						5.6	72
74						72.7m x	74
76						5.4t	76

Unit: ton

Boom Length (m)	48			Boom Length (m)
Jib Length (m)	60			Jib Length (m)
Boom Angle (deg.)	88	80	70	Boom Angle (deg.)
Radius (m)				Radius (m)
20	23.4m x			20
22	35.6t			22
24	35.4			24
26	34.7			26
28	34.1			28
30	32.5			30
32	30.6			32
34	28.9	37.1m x		34
36	27.3	27.0t		36
38	25.9	26.1		38
40	24.6	24.2		40
42	23.4	22.5		42
44	22.3	21.0		44
46	21.3	19.5		46
48	20.3	18.3		48
50	19.5	17.1		50
52	18.7	16.0	54.5m x	52
54	17.9	15.0	9.5t	54
56	17.2	14.1	9.0	56
58	16.2	13.2	8.3	58
60	15.3	12.4	7.7	60
62	14.5	11.7	7.1	62
64	63.5m x	11.0	6.5	64
66	13.0t	10.3	6.0	66
68		9.7	5.5	68
70		9.2	5.1	70
72		70.3m x	70.4m x	72
74		9.1t	5.0t	74

\* For notes about the table above, refer to page 42.

■ Tower 54 m (Rear end Radius: Short)



Unit: ton

Boom Length (m)	54								Boom Length (m)
Jib Length (m)	24				30				Jib Length (m)
Boom Angle (deg.)	88	80	70	60	88	80	70	60	Boom Angle (deg.)
Radius (m)									Radius (m)
10	13.4m x								10
12	72.4t				15.1m x				12
14	71.6				62.8t				14
16	68.2				61.9				16
18	64.0				60.0				18
20	60.3	23.5m x			57.2				20
22	57.2	52.4t			54.2				22
24	54.6	51.1			51.5				24
26	52.5	46.3			49.2	46.1			26
28	42.7	42.2			47.1	42.0			28
30	28.9m x	38.7			44.7	38.5			30
32	36.3t	35.6			41.2	35.5			32
34		32.9	36.4m x		34.4	32.9			34
36		30.5	22.2t		34.7m x	30.5	39.8m x		36
38		36.6m x	20.9		30.8t	28.4	19.3t		38
40		29.8t	19.4			26.6	19.1		40
42			18.0			24.9	17.8		42
44			16.8			42.4m x	16.6		44
46			45.8m x	48.2m x		24.5t	15.5		46
48			15.8t	9.0t			14.5		48
50				8.3			13.6	52.4m x	50
52				7.7			51.6m x	7.3t	52
54				7.1			13.0t	6.9	54
56				54.4m x				6.3	56
58				7.0t				5.9	58
60								5.4	60
62								60.2m x	62
64								5.4t	64

Boom Length (m)	54							Boom Length (m)
Jib Length (m)	36			42				Jib Length (m)
Boom Angle (deg.)	88	80	70	60	88	80	70	Boom Angle (deg.)
Radius (m)								Radius (m)
14	16.8m x							14
16	54.4t				18.5m x			16
18	53.5				47.2t			18
20	52.0				46.3			20
22	50.6				45.1			22
24	48.0				44.0			24
26	45.7	28.4m x			42.7			26
28	43.7	40.6t			40.7	30.9m x		28
30	41.9	37.9			38.9	35.5t		30
32	40.4	34.9			37.3	33.9		32
34	37.8	32.2			35.9	31.2		34
36	35.1	29.9			34.3	28.9		36
38	32.8	27.8			32.0	26.9		38
40	27.8	25.9	43.1m x		29.9	25.0		40
42	40.5m x	24.3	16.4t		28.0	23.4		42
44	25.8t	22.7	15.8		26.3	21.8	46.5m x	44
46		21.4	14.8		22.7	20.5	13.5t	46
48		20.1	13.8		46.3m x	19.2	12.7	48
50		48.1m x	12.9		21.7t	18.1	11.9	50
52		20.0t	12.1			17.0	11.1	52
54			11.3	56.6m x		53.9m x	10.3	54
56			10.6	5.3t		16.1t	9.6	56
58			57.4m x	5.0			9.0	58
60			10.1t	58.2m x			8.4	60
62				5.0t			7.8	62
64							63.2m x	64
66							7.5t	66

\* For notes about the table above, refer to page 42.

■ **Tower 54 m (Rear end Radius: Short)**



Unit: ton

Boom Length (m)	54						Boom Length (m)
Jib Length (m)	48			54			Jib Length (m)
Boom Angle (deg.)	88	80	70	88	80	70	Boom Angle (deg.)
Radius (m)							Radius (m)
18	20.3m x						18
20	40.9t						20
22	40.2			35.9			22
24	39.3			35.1			24
26	38.4			34.4			26
28	37.5			33.7			28
30	36.3	33.3m x		33.0			30
32	34.8	31.7t		32.2	35.7m x		32
34	33.4	30.8		30.9	27.9t		34
36	32.1	28.5		29.6	27.6		36
38	31.0	26.5		28.5	25.5		38
40	29.6	24.6		27.5	23.7		40
42	27.7	23.0		26.6	22.0		42
44	26.0	21.5		25.2	20.5		44
46	24.4	20.1	49.8m x	23.6	19.2		46
48	23.0	18.8	11.5t	22.2	17.9		48
50	21.7	17.7	11.4	20.9	16.8	53.2m x	50
52	18.8	16.6	10.6	19.7	15.8	9.1t	52
54	52.1m x	15.7	9.8	18.6	14.8	8.8	54
56	18.5t	14.8	9.1	17.6	13.9	8.1	56
58		13.9	8.5	57.9m x	13.1	7.5	58
60		59.7m x	7.9	15.6t	12.3	6.9	60
62		13.3t	7.4		11.6	6.4	62
64			6.8		10.9	5.9	64
66			6.3		65.5m x	5.4	66
68			5.9		10.5t	67.7m x	68
70			69.0m x			5.0t	70
72			5.7t				72

Unit: ton



Boom Length (m)	54		Boom Length (m)
Jib Length (m)	60		Jib Length (m)
Boom Angle (deg.)	88	80	Boom Angle (deg.)
Radius (m)			Radius (m)
20	23.7m x		20
22	31.0t		22
24	31.0		24
26	30.6		26
28	30.0		28
30	29.4		30
32	28.9		32
34	28.3		34
36	26.9	38.2m x	36
38	25.5	24.8t	38
40	24.3	23.2	40
42	23.1	21.5	42
44	22.0	20.0	44
46	21.1	18.7	46
48	20.2	17.4	48
50	19.3	16.3	50
52	18.5	15.2	52
54	17.8	14.3	54
56	17.1	13.4	56
58	16.1	12.5	58
60	15.2	11.8	60
62	14.4	11.0	62
64	63.4m x	10.4	64
66	13.3t	9.7	66
68		9.1	68
70		8.6	70
72		71.1m x	72
74		8.3t	74

\* For notes about the table above, refer to page 42.

# Weights and Dimensions of Disassembled Units

## Weights and Dimensions List

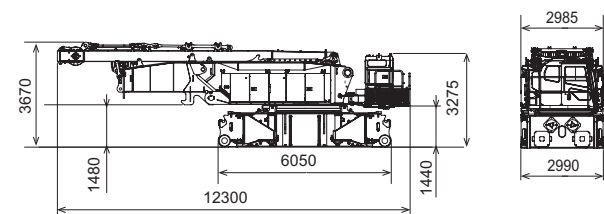
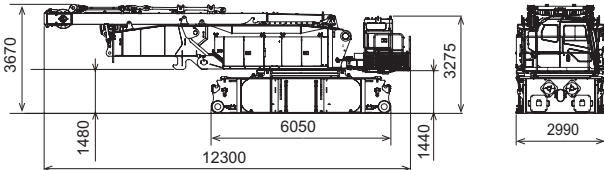
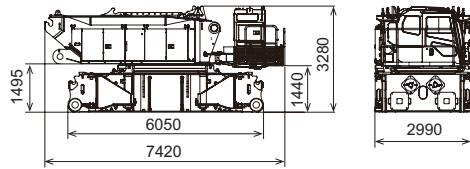
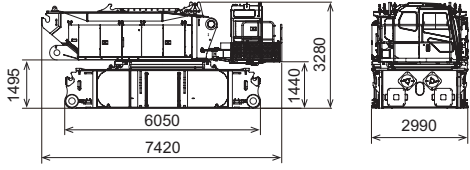
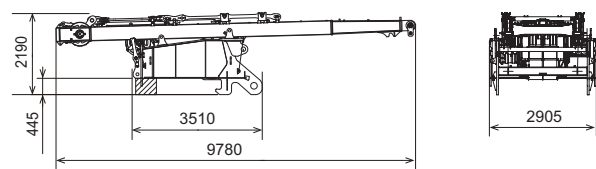
Weights and Dimensions of Disassembled Units

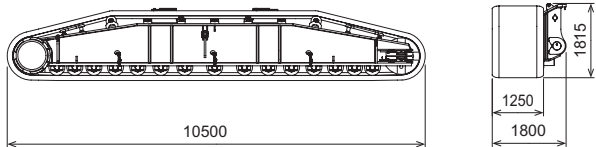
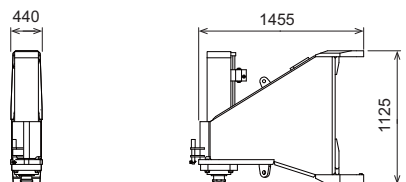
Description	Qty	Dimensions (mm)	Weight (kg)
Front revolving frame + rear revolving frame Mast Jacks Boom hoist winch (including rope)	1		49250
Front revolving frame + rear revolving frame Mast Boom hoist winch (including rope) without: Jacks	1		46600
Front revolving frame Jacks without: Mast Boom hoist winch (including rope)	1		34650
Front revolving frame without: Mast Jacks Boom hoist winch (including rope)	1		32000
Rear revolving frame Mast Boom hoist winch (including rope)	1	 <p>*Stands are for temporary placement only. Use the receiver stand size of  when transporting.</p>	14600
Crawler	2		30200
Jack beam	4		560

Weights and Dimensions of Disassembled Units

Description	Qty	Dimensions (mm)	Weight (kg)
Counter weight (Base)	1		19700
Counter weight	14		8950
Lower weight (For counter weight 145 t specifications)	2		12500
Lower step	2		280
HB9.5 ; 9.5 m Boom base W1, W2, W4 Winch	1	<p data-bbox="539 1435 1326 1458">*Stands are for temporary placement only. Use the receiver stand size of  when transporting.</p>	21800
H6 ; 6 m Boom insert Connect pin Bar pendant (Boom support 6 m and rear strut support 6 m)	2		2700
H6B ; 6 m Boom insert B Connect pin Bar pendant (Boom support 6 m and rear strut support 3m)	1		2700
H9 ; 9 m Boom insert Connect pin Bar pendant (Boom support 9m and rear strut support 9m)	4		3800

Weights and Dimensions of Disassembled Units

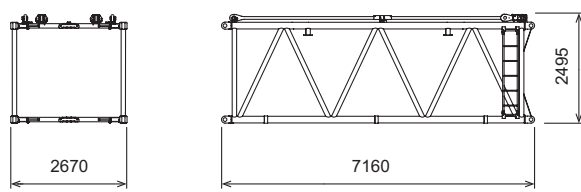
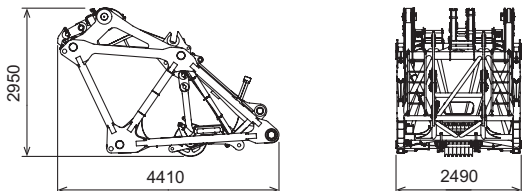
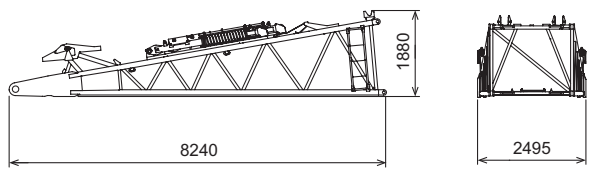
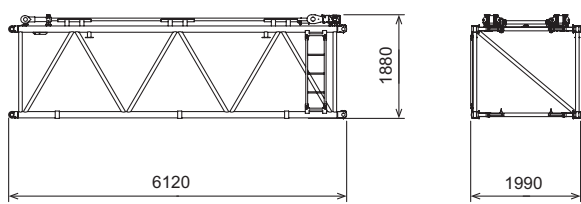
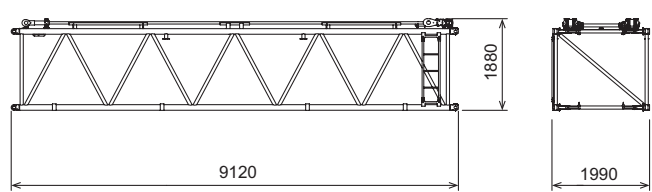
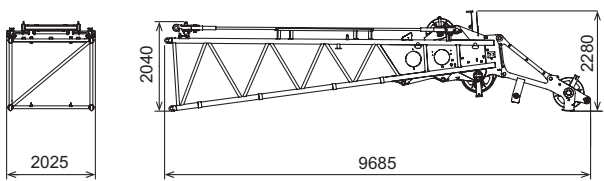
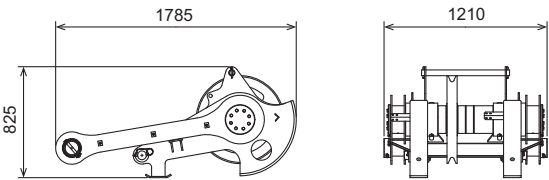
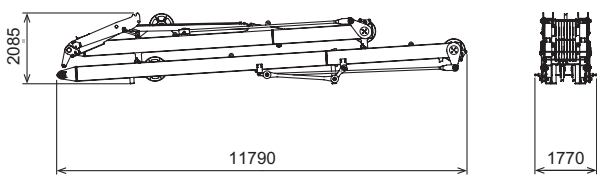
Description	Qty	Dimensions (mm)	Weight (kg)
HR7 ; 7 m Reducer Connect pin Bar pendant (Boom support 7m and rear strut support 7m)	1		3500
HT1.5 ; 1.5 m Boom top	1		5400
LB8 ; 8 m Tower/luffing jib base	1		3120
L6 ; 6 m Tower/luffing jib insert Connect pin Pendant	3		1500
L9 ; 9 m Tower/luffing jib insert Connect pin Pendant	3		2000
LT7 ; 7 m Tower/luffing jib top	1		3400
For boom top Aux. sheave block	1		610
Front strut Rear strut	1		7800

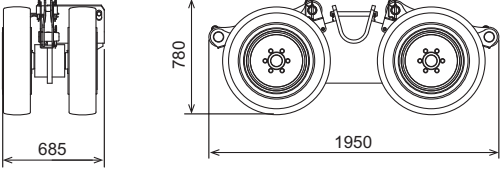
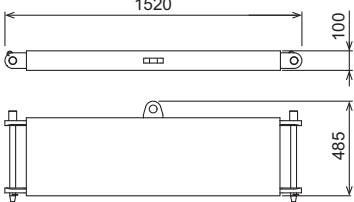
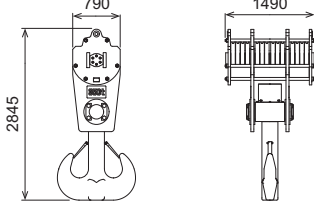
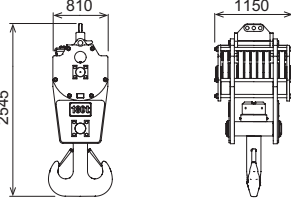
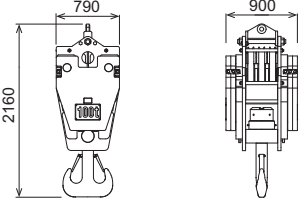
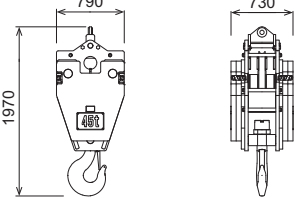
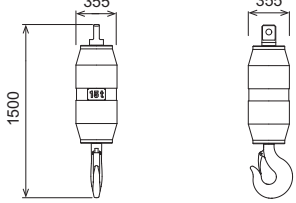

Weights and Dimensions of Disassembled Units

Description	Qty	Dimensions (mm)	Weight (kg)
Tower/luffing jib top tip roller	2		530
Tower/luffing jib top weight	2		420
350 t Hook	1		4440
180 t Hook	1		3340
100 t Hook	1		3110
45 t Hook	1		2170
15 t Hook	1		620

# Equipment List

## Standard and Optional Equipment

○ : Standard ● : Optional — : No setting

Item		Crane	Crane / Tower
Lower Structure	1250 mm Crawler Shoe	○	○
	Jack Up Unit	○	○
	Steps	○	○
	Shoe Tension Unit (Shim Adjusting Type)	○	○
Upper Structure	Upper House Handrails	○	○
	Under Cover (Bed Lower Surface)	○	○
	Working Light (×2)	○	○
	Back Mirror (Left / Right)	○	○
	Flip Cylinder	○	○
	Auto Idle Stop	○	○
	Eco Mode	○	○
Cab	Tilt Cab (0 to 15°)	○	○
	Air Conditioner	○	○
	Sunvisor	○	○
	Sunshade	○	○
	Wiper with Washer (Front Window, Cab Roof Window)	○	○
	Microphone & Loud-speaker	○	○
	AM / FM Radio (with Clock)	○	○
	Room Lamp	○	○
	Cup Holder	○	○
	24 V Power Socket (×2)	○	○
	Floor Carpet	○	○
	Level Gauge (in Cab)	○	○
	Accelerator Grip	○	○
	Drum Rotation Sensor [Front (W1) / Rear (W2) / Boom Hoist (W3) / Jib Hoist (W4)]	○	○
	Speed Control Dial [Front (W1) / Rear (W2) / Boom Hoist (W3) / Jib Hoist (W4)]	○	○
	Arm Chair Lever	○	○
	Accelerator Pedal (Right Side)	●	●
	Boom Hoist Operation Pedal	●	●
	Swing Brake Operation Pedal	●	●
	Fan	●	●
Fuel Burning Heater	●	●	
Life Hammer	○	○	
Attachment	24m Basic Boom (HB9.5: 9.5m Boom Base, HR7: 7m Reducer, H6B: 6m Boom Insert B, HT: 1.5m Boom Top)	○	○
	H6: 6m Boom Insert (Including Boom Steps, Skywalk, Stanchion)	●	○
	H9: 9m Boom Insert (Including Boom Steps, Skywalk, Stanchion)	●	○
	Auxiliary Sheave for Crane [Including Auxiliary Sheave, Anti-two Block]	●	●
	24m Tower Jib (LB8: Tower/Luffing Jib Base: 8m, L9: 9m Tower/Luffing Jib Insert, LT7: Tower/Luffing Jib Top: 7m)	—	○
	L6: 6m Jib Insert	—	○
	L9: 9m Jib Insert	—	○
	Auxiliary Sheave for Tower Jib[Including Auxiliary Sheave, Anti-two Block]	—	○
	Hammer Head only for 350t Lifting [Including Anti-two Block]	●	●
	Boom Foot Pin Removal / Installation Cylinder	○	○
	350t Hook (14 Sheaves)	●	●
	180t Hook(7 Sheaves)	●	●
	100t Hook(3 Sheaves)	●	●
Wire rope	Front (W1) Winch ( φ 28)	●	●
	Rear (W2) Winch( φ 28)	○	○
	Boom Hoist (W3) Winch( φ 28)	○	○
	Jib Hoist(W4) Winch( φ 28)	—	○
	15t Hook	●	●

○ : Standard ● : Optional — : No setting

Item		Crane	Crane / Tower
Safety Device	Moment Limiter	○	○
	3 Color Percentage Indicator Light	○	○
	Gate Lock Lever	○	○
	Individual Winch Operation Lever Lock [Front (W1), Rear (W2), Boom Hoist (W3), Jib Hoist (W4), Travel]	○	○
	Automatic Drum Lock [Boom Hoist (W3), Jib Hoist (W4)]	○	○
	Winch Drum Lock [Front (W1), Rear (W2)]	○	○
	Swing Lock	○	○
	Swing Alarm	○	○
	Travel Alarm	○	○
	Auto Slowdown (Slow Stop)	○	○
	Boom Hoist Limiting Device	○	○
	Secondary Boom Overhoist Prevent Device	○	○
	Warning Alarm	○	○
	Engine Start Interlock System	○	○
	Emergency Engine Stop Switch (In cab)	○	○
	Lifting Height Indication Device	○	○
	Swing Neutral Free/Brake Selection Switch	○	○
	Anti-two Block	○	○
	Tower/Luffing Jib Overhoist Prevention Device	—	○
	Secondary Tower/Luffing Jib Overhoist Prevention Device	—	○
	Swing Restriction Unit	●	●
	Lowering Limiter	● / ○ <sup>*1</sup>	● / ○ <sup>*1</sup>
	Anemometer (HH 1.5)	●	●
	Anemometer (HT 1.5)	●	●
Anemometer (LT 7)	●	●	
Crane Boom Top Camera Monitor System	●	●	
Tower/Luffing Jib Top Camera Monitor System	●	●	
Drum and Rear View Monitor System (× 6)	●	●	
Cab Roof Window Guard	● / ○ <sup>*1</sup>	● / ○ <sup>*1</sup>	
Common parts	Boom Back Stop	○	○
	Boom Angle Sensor	○	○
	Boom Lifting Piece	○	○
	Remote Sensing (Data Logging Device)	○ <sup>*2</sup>	○ <sup>*2</sup>
	Assembly Pad	●	●
	Quick Draw for Side Frame Self Assembly	●	●
	External Hydraulic Power	●	○
	Reeving Winch (4 × F(30) φ 8mm × 250m)	●	●
	Reduction Counter Weight Specification	●	●
	Sling Ropes for Disassembly and Assembly (Belt Sling, Sling Wire, Shackle)	○	○
	HB9.5: 9.5m Boom Base Side Footing	●	●
	Handy Cylinder for Connecting Boom	●	●
	Bracket for Coupling Cylinder	●	●
	Guide Roller for Nesting Boom	●	●
	Additional Spare Parts (Hydraulic Oil Filter)	●	●
	Additional Tools (Large Hammer, Crowbar, Chisel)	●	●
Other	Standard Supplied Tools	○	○
	Standard Spare Parts	○	○

\*1 Europe specification only.

\*2 "Mobile Communication Terminal" or "Satellite Communication Terminal" depends on the communication regulations of each country.

- We are constantly improving our products and therefore reserve the right to change designs and specifications without notice.
- Units in this specification are shown under International System of Units; the figures in parenthesis are under Gravitational System of Units as old one.

---

## **Hitachi Sumitomo Heavy Industries Construction Crane Co.,Ltd.**

9-3, Higashi-Ueno 6-chome, Taito-ku, Tokyo 110-0015, Japan  
Phone: 81-3-3845-1387 Facsimile: 81-3-3845-1394

**<http://www.hsc-crane.com>**