

# ZAXIS 210 LC-3

## 5-Stage Telescopic Crawler Crane

POWER THAT WON'T QUIT

### Crane Specifications

ZX210LC-3

Gross Weight (kgs)	21,750kg
Overall Length (m)	9.45m
<b>CRANE CAPACITY</b>	
Max. lifting load x Working radius: t x m	10.0 x 2.0
Max. hook height above ground: m	23.5 (4 parts of line)
Max. hooklift under ground: m	21.5 (4 parts of line)
Boom Length	6.00 Metres to 21.00 Metres ( + optional 3.8M Jib)
Boom Elevation Angle	-3 degrees ~ 76 degrees
Boom Elevation Speed	-3 degrees ~ 76 degrees / 15s
Boom Extension Speed	14.4M/33S
Hoisting Speed m/min	High 97 / Low 66
Hoisting Rope	14mm x 105Meters (Construction 19x7 IWRC Non Rotating rhol wire rope)
Swing Speed	13.3 min-1 (rpm)
Travel Speed	5.5 km/h
<b>ENGINE</b>	
Model	ISUZU AI-4HK1X
Rated Output (kW(PS)/rpm)	122(164) at 2000

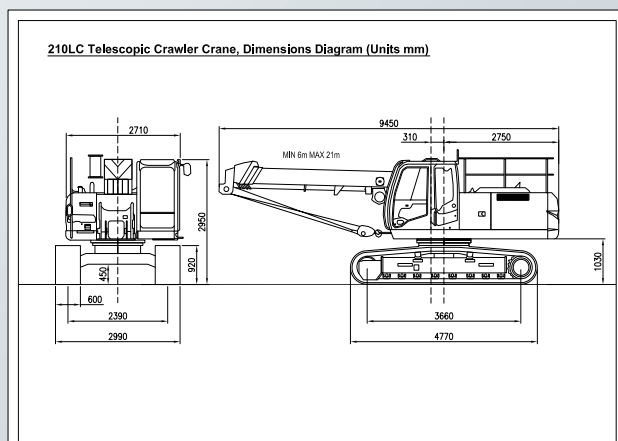

# HITACHI Crane Rating ZX210LC-3

(Unit Kg)

Working Radius (M)	6.0M BOOM		9.80M BOOM		13.60M BOOM		17.30M BOOM		21.00M BOOM		21M BOOM+3.8M JIB	
	STATIC	MOBILE	STATIC	MOBILE	STATIC	MOBILE	STATIC	MOBILE	STATIC	MOBILE	STATIC	MOBILE
2.00	10000	3500										
3.00	6500	3500	5940	2970	2800	1400	2320	not allowed	1880	not allowed		
4.00	5200	2600	4600	2300	2800	1400	2320	not allowed	1880	not allowed	1050	not allowed
5.00	4400	2200	3800	1900	2660	1330	2320	not allowed	1880	not allowed	1050	not allowed
6.00	4230 (5.4)	2115	3240	1620	2340	1170	2150	not allowed	1880	not allowed	1050	not allowed
7.00			2690	1345	2180	1090	1960	not allowed	1780	not allowed	1050	not allowed
8.00			2440	1220	2100	1050	1810	not allowed	1610	not allowed	910	not allowed
9.00			2060	1030	2000	1000	1750	not allowed	1540	not allowed	830	not allowed
10.00			1980 (9.2)	990	1840	920	1660	not allowed	1470	not allowed	760	not allowed
11.00					1620	810	1500	not allowed	1380	not allowed	720	not allowed
12.00					1430	715	1340	not allowed	1280	not allowed	660	not allowed
13.00					1280	640	1190	not allowed	1140	not allowed	610	not allowed
14.00							1140	not allowed	1090	not allowed	570	not allowed
15.00							1030	not allowed	990	not allowed	520	not allowed
16.00							920	not allowed	890	not allowed	420	not allowed
17.00							910 (16.7)	not allowed	810	not allowed	400	not allowed
18.00									740	not allowed	370	not allowed
19.00									710	not allowed	350	not allowed
20.00									650	not allowed		
21.00									650 (20.5)	not allowed		

- The rated loads are determined according to DIN 15018 part 3 (lifting class H2, loading group B2). The stability is according to EN13000 (2004). The rated loads listed are based on the condition that the machine is stationed on firm, level ground. The rated loads are available over 360 degrees. The rated loads shown include the weight of all lifting attachments, such as hook and bucket. The load to be actually lifted is the rated load minus the weight of all lifting attachments.
- Counterweight of 4,750kgs is fixed to crane.
- Travelling is allowed according and provided that:
  - surface must be firm and level
  - the boom is in travelling direction
  - speed is not above 0.4m/s (on a firm level ground)
  - the load is near the ground (0.5m) and secured against swaying
  - no other movements are allowed
- Standard reeving for working 2 or 4 or 6 reeving's.
- At windforce of 14m/s or more the operation must be stopped. By windforce of 15m/s or more the boom must be retracted to the minimum and lowered to the ground.
- For the wind load area of the rated load is 1,2m<sup>2</sup> per 1000kg calculated.

**210LC Telescopic Crawler Crane, Working Range Diagram**

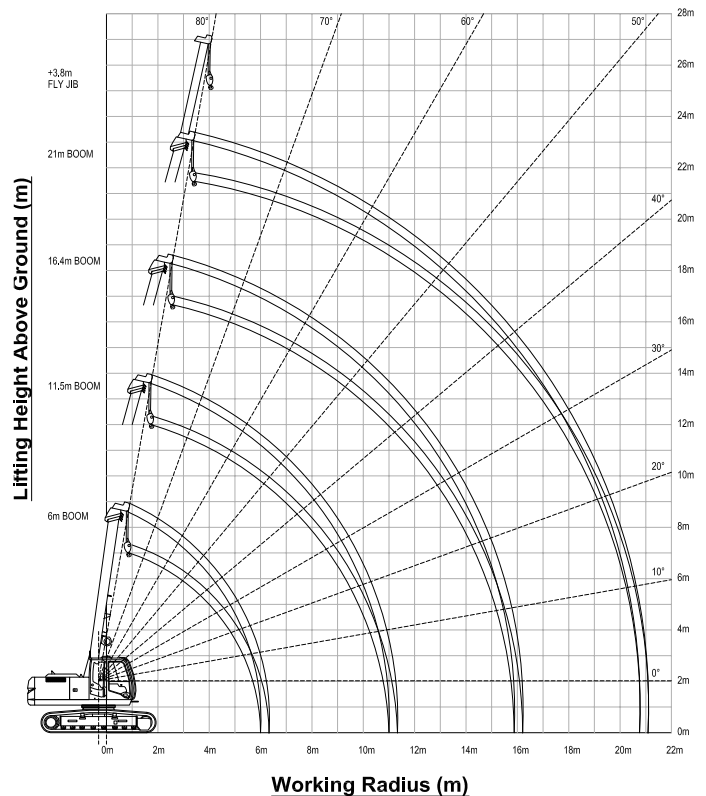

**Note:**  
 This diagram does not include deflection of boom and fly jib.