

COMPACT-CLASS EXCAVATORS

ZAXIS

DASH-5

ZX35U-5

ZX50U-5

ZX60USB-5



HITACHI

Courtesy of Machine.Market

BY NOT BUILDING EVERYTHING, WE COMPROMISE ON NOTHING.

EXCAVATOR EXPERTS.

At Hitachi, we don't get sidetracked building every kind of construction equipment. Instead, we build excavators. It's that kind of engineering and manufacturing focus that results in our reputation for highly efficient, reliable and durable machines.

Small and compact, the ZX35U-5, ZX50U-5 and ZX60USB-5 give you big-time performance on all kinds of jobs. You get a more spacious cab with wider, easier entry and better visibility; a fuel-efficient and reliable engine that meets emission standards; and maintenance that's easier than ever thanks to enhancements such as improved access to coolers. Add it all up, when you choose Hitachi Dash-5 Compact Excavators, you get...

IMPROVED PERFORMANCE.





■ Yanmar diesel engines meet EPA Final Tier 4 (FT4)/EU Stage IV emissions regulations. Easy-to-maintain, they require no special, additional fluids – just ultra-low-sulfur diesel fuel and CJ-4 engine oil.

■ Updated door design provides improved visibility and more room for entering the cab – a key operator-requested improvement over the previous models.

■ An additional service door provides convenient cooler access, making core clean-out quicker and easier.

MORE PRODUCTIVITY IN MORE PLACES.

A SIZEABLE IMPACT ON PRODUCTIVITY.

No doubt about it. With their reduced- and zero-tail-swing designs, these compact, yet powerful excavators are perfect for work in congested or confined areas. But they're not just close-quarters contributors. Easy to load and transport between jobs, these models are also smart choices for trenching, excavating, loading trucks and other tasks in wide-open spaces. Fuel-efficient, direct-injected Yanmar engines are FT4-certified and are impressively quiet – so you can run them almost anywhere, anytime. When you've got these compact excavators on your team, you can...

WORK EVERYWHERE, EVERY DAY.



■ Although not a replacement for a grading tractor, standard backfill blades let these excavators fill in quite capably. An optional all-hydraulic blade angles 25 degrees, left or right, for even more efficient grading and backfilling.



■ Choose the tracks that are best for the way you work. The rubber tracks traverse virtually any terrain, including paved surfaces. Also available are steel tracks and steel tracks with rubber pads. The optional rubber grousers combine work-anywhere flexibility with steel-track serviceability.



■ Don't let obstacles get in the way of your work. The independent-swing boom and 360-degree rotation let you set up and work nearly anywhere.



■ Visibility that's practically unlimited, precise feel and smooth, accurate control make Dash-5 compacts a great fit for excavating in and around existing utilities.

PRODUCTIVITY



■ With plenty of lift height and reach, getting up and over truck sideboards is all in a day's work.



■ Standard quick-coupler equipped, boom-mounted auxiliary hydraulic lines make attachment hook-up a snap.

■ Wedge-style coupler enables quick changes and a wide variety of buckets and attachments, such as breakers and augers.

■ Match engine speed to the job with power/economy work modes. Choose the power mode and get higher engine speeds for most general digging work. For lighter digging jobs, the economy mode reduces engine speed and noise, and lowers fuel costs.

■ When the going gets tough, the powerful Yanmar diesel engines give you high-level torque for more pull-through power.



- Spacious operator stations have wide entryways, making entry and exit easier than ever. Flat, skid-resistant floor mats remove easily for clean-out.

- Redesigned cab's 50-mm (2-in.) wider, 150-mm (6-in.) taller front glass; and single-hinge door provide unsurpassed all-around visibility.

- Swing boom and foldable travel pedals are positioned where they're easy to operate, yet allow plenty of foot room.

- Noise-reducing muffler (ZX35U-5) and after-treatment device (ZX50U-5/ZX60USB-5), plus isochronous high-idle speed, help keep things noticeably quiet. Rubber cab mounts further isolate the operator from noise and vibration to help reduce fatigue.

- Auto-idle automatically reduces engine speed when hydraulics aren't in use. Auto-shutdown further preserves every precious drop of fuel.

- No operator activation required for high-speed travel. Track speeds automatically slow to low whenever the travel motors encounter a heavier load. Includes a console-mounted, low-speed lock switch.

- Convenient 12-volt port powers cell phones and other electronic devices. There's also a large cup holder and seat back compartment for documents.

THE PERFECT FIT FOR OPERATOR COMFORT AND PRODUCTIVITY.

A BIGGER, BETTER COMFORT ZONE.

Good news. Your operators won't have to squeeze their way aboard our excavators. Our comfortable work stations are spacious, with wide entryways to ease entry and exit. Seat, pedals and controls are positioned to accommodate bigger operators. And virtually unobstructed visibility provides a clear view of the work ahead and surrounding jobsite. For year-round comfort and increased productivity, add a heated and air-conditioned cab. Step aboard a Hitachi compact excavator, and you'll experience...

MORE COMFORT, MORE PRODUCTIVE DAYS.



■ Enhanced monitor provides vital operating info at a glance and fingertip control of several functions, including auto-shutdown, power/economy modes and auto exhaust filter cleaning. Plus, two trip meters let you track engine oil and hydraulic oil changes, or jobsite hours.



■ Go from backhoe- to excavator-style controls with just a twist of your wrist. Control-pattern selector valve is conveniently located in a compartment beneath the seat.



■ Ergonomic short-throw pilot control levers provide smooth, predictable low-effort fingertip operation.



■ Automatic, high-velocity bi-level climate-control system with automotive-style adjustable louvers help keep the glass clear and the cab comfortable.

- O-ring face-seal hydraulic fittings virtually eliminate aggravating and costly oil leaks.

- Rigid, reinforced D-channel side frames resist impact, providing maximum cab and component protection.

- Self-priming diesel helps you get back up and running quickly should you ever run out of fuel.

- Oil-impregnated bushings enhance durability and extend grease intervals to 500 hours for the arm-and-boom joint, and 100 hours for the bucket.

- To help prevent accidental machine movement, a spring-applied, hydraulically released park brake automatically engages when a control lever is released.

- Wet-disc swing brake provides long-term maintenance-free performance.

STRONG-ARMED PERFORMANCE.

TOUGH ENOUGH FOR YOUR TOUGHEST JOBS.

Our compacts are smaller, but they're no less durable. Built to the same high standards as our larger excavators, they're armed with exactly what you need. Oil-impregnated boom, arm and bucket bushings increase digging structure durability. Reinforced D-channel side frames protect components from impact damage. And heavy-duty cast or box-constructed fabricated X-frames provide a rock-solid base. The closer you look at Dash-5 compacts, the more you'll see...

DURABILITY THAT INCREASES YOUR ABILITY.



■ Single-pin swing-post increases boom stiffness, enhancing the structural integrity of the digging components. Wear-resistant hoses are routed for protection and Cordura®-wrapped where exposed.



■ Heavy-duty shields deflect boom/blade cylinders and drive motors.



■ Rubber tracks' unique steel cores resist cracking. Large-diameter drive sprockets and track idlers further increase undercarriage durability.



■ Heavy-duty X-frame provides a solid, stable platform that resists material and dirt build-up.

SMOOTHER EFFICIENCY IN A ROUGH WORLD.

HARD WORK MADE EASIER AND LESS COSTLY.

If there's a way to increase uptime, reduce your daily operating costs and simplify maintenance, we've implemented it in the Dash-5 Series. Extended hydraulic and engine oil change intervals reduce downtime and expense. Daily checks are done through a steel rear door that slides up and out of the way. The operator station tilts forward, providing quick, wide-open component access. And of course, industry leading parts and service are just as easily accessible at all Hitachi dealers. Put these excavators to work and expect ...

EFFICIENCY ON EVERY JOB, EVERY DAY.



■ Vertical spin-on filters allow quick and clean changes. Extended engine and hydraulic oil intervals let you work longer.



■ Hinged door provides wide-open access to the side-by-side oil cooler and radiator for easier core cleanout.



■ Operator station tilts forward 50 degrees, simplifying access to the swing motor, hydraulic control valve, engine starter motor and alternator.



■ Routine checks such as engine oil level are quickly accomplished from ground level. Convenient lube/maintenance chart helps ensure that nothing gets overlooked.



EFFICIENT



■ Hydraulic fluid sight gauge and see-through coolant reservoir let you quickly check levels at a glance.

■ A simple grease gun and a wrench are all it takes to quickly maintain proper track tension.

■ Large fuel tanks and 500- and 2,000-hour engine and hydraulic oil-service, and 500-hour greasing intervals enable these excavators to work longer between stops for scheduled service.

■ EPA Final Tier 4 (FT4)/EU Stage IV technology in our excavators is simple, fuel-efficient, fully integrated and fully supported. In the ZX50U-5 and ZX60USB-5, it employs field-proven cooled exhaust gas recirculation (EGR) for reducing NO_x, and a diesel particulate filter (DPF) and diesel oxidation catalyst (DOC) to reduce particulate matter. The ZX35U-5 does not require an after-treatment system to meet EPA requirements.

■ Seamless diesel particulate filter (DPF) cleaning happens automatically without impacting machine productivity. The service interval is 6,000 hours and can be done by your Hitachi dealer.

■ Fuel-sipping diesels, auto-idle and economy work mode help preserve precious fuel.

Engine	ZX35U-5			
Manufacturer and Model	Yanmar 3TNV88F			
Non-Road Emission Standard	EPA Final Tier 4/EU Stage IV			
Displacement	1.642L (100.2 cu. in.)			
Net Power (ISO 9249)	17.4 kW (23.3 hp) @ 2,400 rpm			
Powertrain	Each track independently driven by hydrostatic axial-piston motor connected to 2-stage planetary gear-reduction box			
Maximum Travel Speed				
Low	2.8 km/h (1.7 mph)			
High	4.3 km/h (2.7 mph)			
Hydraulics	Open center with 2 variable-displacement pumps and 1 fixed-gear pump			
Pump Flow				
Piston	2 x 38.4 L/m (2 x 10.1 gpm)			
Gear	22.8 L/m (6.0 gpm)			
Auxiliary Flow	61.2 L/m (16.2 gpm)			
Controls	2 hydraulic pilot-operated controls for boom, arm, bucket, swing, boom swing, travel and auxiliary functions			
Electrical				
Alternator Rating	55 amp			
Working Lights	2 halogen: 1 mounted on operator's station and 1 mounted on boom			
Undercarriage				
Track, Rubber	300 mm (12 in.)			
Ground Pressure	1315-mm (4 ft. 4 in.)	1315-mm (4 ft. 4 in.)	1715-mm (5 ft. 8 in.)	1715-mm (5 ft. 8 in.)
	Standard Arm, Canopy and Standard Counterweight	Standard Arm, Cab and Standard Counterweight	Long Arm, Canopy and Extra Counterweight	Long Arm, Cab and Extra Counterweight
With Rubber Track	32.0 kPa (4.6 psi)	33.0 kPa (4.8 psi)	33.7 kPa (4.9 psi)	35.2 kPa (5.1 psi)
Upperstructure				
Swing Speed	9.0 rpm			
Independent Swing Boom	Canopy	Cab		
Left	72 deg.	62 deg.		
Right	62 deg.	62 deg.		
Swing Brake	Spring-applied, hydraulically released, automatic, disc type			
Serviceability				
Refill Capacities				
Fuel Tank	42 L (11.1 gal.)			
Cooling System	5.0 L (5.3 qt.)			
Engine Oil with Filter	7.2 L (7.6 qt.)			
Hydraulic Tank	32 L (8.5 gal.)			
Operating Weights	1315-mm (4 ft. 4 in.)	1315-mm (4 ft. 4 in.)	1715-mm (5 ft. 8 in.)	1715-mm (5 ft. 8 in.)
	Standard Arm, Canopy and Standard Counterweight	Standard Arm, Cab and Standard Counterweight	Long Arm, Canopy and Extra Counterweight	Long Arm, Cab and Extra Counterweight
With Full Fuel Tank and 79-kg (175 lb.) Operator	3520 kg (7,760 lb.)	3690 kg (8,135 lb.)	3783 kg (8,340 lb.)	3953 kg (8,715 lb.)
Optional Angle Blade	296 kg (653 lb.)			
Counterweight				
Standard	540 kg (1,190 lb.)			
Additional	240 kg (529 lb.)			

Operating Dimensions

ZX35U-5

	1315-mm (4 ft. 4 in.) Standard Arm and Canopy	1715-mm (5 ft. 8 in.) Long Arm and Canopy	1315-mm (4 ft. 4 in.) Standard Arm and Cab	1715-mm (5 ft. 8 in.) Long Arm and Cab
A Maximum Cutting Height	4.87 m (16 ft. 0 in.)	4.95 m (16 ft. 3 in.)	4.70 m (15 ft. 5 in.)	4.74 m (15 ft. 7 in.)
B Maximum Dumping Height	3.46 m (11 ft. 4 in.)	3.57 m (11 ft. 9 in.)	3.31 m (10 ft. 10 in.)	3.39 m (11 ft. 1 in.)
C Maximum Digging Depth	3.06 m (10 ft. 0 in.)	3.46 m (11 ft. 4 in.)	3.06 m (10 ft. 0 in.)	3.46 m (11 ft. 4 in.)
D Maximum Digging Reach	5.21 m (17 ft. 1 in.)	5.52 m (18 ft. 1 in.)	5.21 m (17 ft. 1 in.)	5.52 m (18 ft. 1 in.)
E Minimum Front Swing Radius	2.08 m (6 ft. 10 in.)	2.19 m (7 ft. 2 in.)	2.24 m (7 ft. 4 in.)	2.30 m (7 ft. 7 in.)
F Transport Length	4.64 m (15 ft. 3 in.)	4.75 m (15 ft. 7 in.)	4.64 m (15 ft. 3 in.)	4.75 m (15 ft. 7 in.)
Digging Force (ISO)				
Arm	19.0 kN (4,277 lb.)	16.9 kN (3,792 lb.)	19.0 kN (4,277 lb.)	16.9 kN (3,792 lb.)
Bucket	27.1 kN (6,085 lb.)	27.1 kN (6,085 lb.)	27.1 kN (6,085 lb.)	27.1 kN (6,085 lb.)

Machine Dimensions

G Upperstructure Width	1.55 m (5 ft. 1 in.)
H Overall Height	
Canopy	2.48 m (8 ft. 2 in.)
Cab	2.48 m (8 ft. 2 in.)
I Track Width	300 mm (12 in.)
J Undercarriage Width	1.74 m (5 ft. 9 in.)
K Ground Clearance	280 mm (11 in.)
L Tail Swing Radius	
With Standard Arm	870 mm (34 in.)
With Long Arm and Extra Counterweight	980 mm (39 in.)
M Engine Cover Height	1.53 m (5 ft. 0 in.)
N Maximum Blade Lift Above Ground	360 mm (14.2 in.)
O Maximum Blade Drop Below Ground	400 mm (15.7 in.)
Blade	
Width	1.74 m (5 ft. 9 in.)
Height	373 mm (14.7 in.)
P Sprocket Center to Idler Center	1.66 m (5 ft. 5 in.)
Q Undercarriage Length	2.11 m (6 ft. 11 in.)
R Counterweight Clearance	550 mm (22 in.)

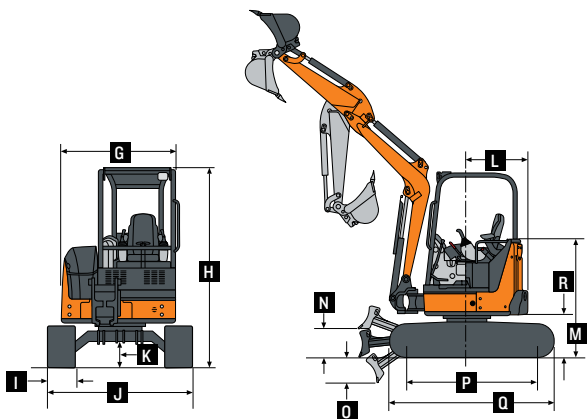
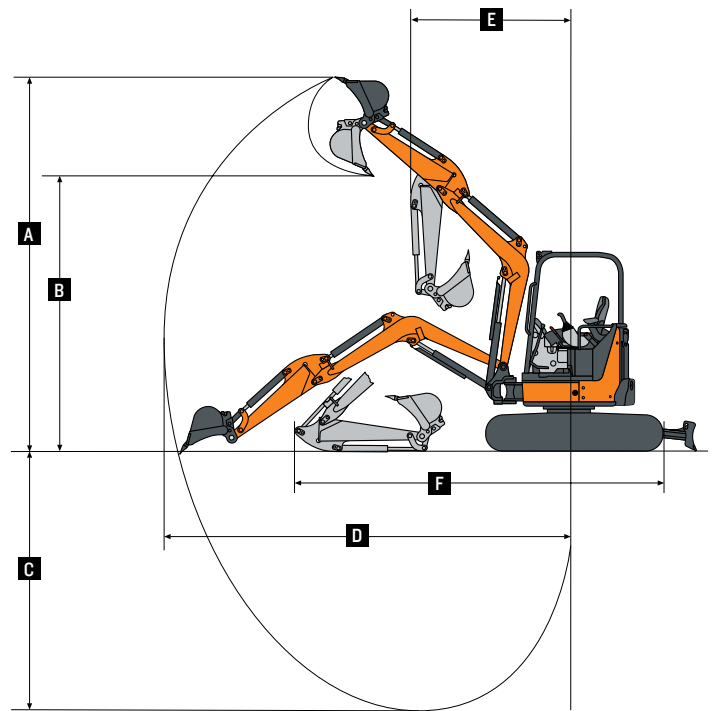

Lift Capacities

Ground Level at 3.05-m (10 ft.) Radius

Arm	Canopy and Standard Counterweight		Canopy and Extra Counterweight		Cab and Standard Counterweight		Cab and Extra Counterweight	
	Over Front*	Over Side	Over Front	Over Side	Over Front*	Over Side	Over Front*	Over Side
1315-mm (4 ft. 4 in.) Standard	1568 kg (3,453 lb.)	641 kg (1,412 lb.)	1568 kg (3,453 lb.)	765 kg (1,686 lb.)	1568 kg (3,453 lb.)	684 kg (1,506 lb.)	1568 kg (3,453 lb.)	808 kg (1,780 lb.)
1715-mm (5 ft. 8 in.) Long	1501 kg (3,307 lb.)	630 kg (1,388 lb.)	1501 kg (3,307 lb.)	755 kg (1,662 lb.)	1501 kg (3,307 lb.)	672 kg (1,481 lb.)	1501 kg (3,307 lb.)	797 kg (1,756 lb.)

*Blade down (limited by hydraulics).

Engine	ZX50U-5			
Manufacturer and Model	Yanmar 4TNV88C			
Non-Road Emission Standard	EPA Final Tier 4/EU Stage IV			
Displacement	2.19 L (134 cu. in.)			
Net Power (ISO 9249)	26.8 kW (35.9 hp) at 2,400 rpm			
Powertrain	Each track independently driven by hydrostatic axial-piston motor connected to 2-stage planetary gear-reduction box			
Maximum Travel Speed				
Low	2.5 km/h (1.6 mph)			
High	4.2 km/h (2.6 mph)			
Hydraulics	Closed center load-sensing with 1 variable-displacement pump			
Pump Flow	120.0 L/m (31.7 gpm)			
Auxiliary Flow	87.4 L/m (23.1 gpm)			
Controls	Hydraulic pilot-operated controls for boom, arm, bucket, swing, boom swing, blade, travel and auxiliary functions			
Electrical				
Alternator Rating	55 amp			
Working Lights	2 halogen: 1 mounted on operator's station and 1 mounted on boom			
Undercarriage				
Track, Rubber	400 mm (16 in.)			
Ground Pressure	1380-mm (4 ft. 6 in.)	1380-mm (4 ft. 6 in.)	1690-mm (5 ft. 7 in.)	1690-mm (5 ft. 7 in.)
	Standard Arm, Canopy and Standard Counterweight	Standard Arm, Cab and Standard Counterweight	Long Arm, Canopy and Extra Counterweight	Long Arm, Cab and Extra Counterweight
With Rubber Track	26.9 kPa (3.90 psi)	28.3 kPa (4.10 psi)	28.8 kPa (4.17 psi)	29.5 kPa (4.28 psi)
Upperstructure				
Swing Speed	9.0 rpm			
Independent Swing Boom				
Left	80 deg.			
Right	60 deg.			
Swing Brake	Spring-applied, hydraulically released, automatic, disc type			
Serviceability				
Refill Capacities				
Fuel Tank	70 L (18.5 gal.)			
Cooling System	5.0 L (5.3 qt.)			
Engine Oil with Filter	8.6 L (9.1 qt.)			
Hydraulic Tank	56 L (14.8 gal.)			
Operating Weights	1380-mm (4 ft. 6 in.)	1380-mm (4 ft. 6 in.)	1690-mm (5 ft. 7 in.)	1690-mm (5 ft. 7 in.)
	Standard Arm, Canopy and Standard Counterweight	Standard Arm, Cab and Standard Counterweight	Long Arm, Canopy and Extra Counterweight	Long Arm, Cab and Extra Counterweight
With 400-mm (16 in.) Rubber Track, Straight Blade, Full Fuel Tank and 79-kg (175 lb.) Operator	4790 kg (10,560 lb.)	4920 kg (10,847 lb.)	5018 kg (11,063 lb.)	5148 kg (11,349 lb.)
Optional Angle Blade	409 kg (902 lb.)			
Counterweight				
Standard	700 kg (1,543 lb.)			
Additional	200 kg (441 lb.)			

Operating Dimensions

ZX50U-5

	1380-mm (4 ft. 6 in.) Standard Arm and Canopy	1690-mm (5 ft. 7 in.) Long Arm and Canopy	1380-mm (4 ft. 6 in.) Standard Arm and Cab	1690-mm (5 ft. 7 in.) Long Arm and Cab
A Maximum Cutting Height	5.75 m (18 ft. 10 in.)	6.00 m (19 ft. 8 in.)	5.75 m (18 ft. 10 in.)	6.00 m (19 ft. 8 in.)
B Maximum Dumping Height	4.07 m (13 ft. 4 in.)	4.31 m (14 ft. 2 in.)	4.07 m (13 ft. 4 in.)	4.31 m (14 ft. 2 in.)
C Maximum Digging Depth	3.53 m (11 ft. 7 in.)	3.83 m (12 ft. 7 in.)	3.53 m (11 ft. 7 in.)	3.83 m (12 ft. 7 in.)
D Maximum Digging Reach	5.96 m (19 ft. 7 in.)	6.26 m (20 ft. 6 in.)	5.96 m (19 ft. 7 in.)	6.26 m (20 ft. 6 in.)
E Minimum Front Swing Radius	2.21 m (7 ft. 3 in.)	2.30 m (7 ft. 7 in.)	2.21 m (7 ft. 3 in.)	2.30 m (7 ft. 7 in.)
F Transport Length	5.47 m (17 ft. 11 in.)	5.52 m (18 ft. 1 in.)	5.47 m (17 ft. 11 in.)	5.52 m (18 ft. 1 in.)
Digging Force (ISO)				
Arm	24.0 kN (5,401 lb.)	21.0 kN (4,718 lb.)	24.0 kN (5,401 lb.)	21.0 kN (4,718 lb.)
Bucket	36.8 kN (8,267 lb.)	36.8 kN (8,267 lb.)	36.8 kN (8,267 lb.)	36.8 kN (8,267 lb.)

Machine Dimensions

G Upperstructure Width	1.85 m (6 ft. 1 in.)
H Overall Height	
Canopy	2.53 m (8 ft. 4 in.)
Cab	2.53 m (8 ft. 4 in.)
I Track Width	400 mm (16 in.)
J Undercarriage Width	2.00 m (6 ft. 7 in.)
K Ground Clearance	340 mm (13 in.)
L Tail Swing Radius	
With Standard Arm	1.00 m (39 in.)
With Long Arm and Extra Counterweight	1.10 m (43 in.)
M Engine Cover Height	1.59 m (5 ft. 3 in.)
N Maximum Blade Lift Above Ground	460 mm (18 in.)
O Maximum Blade Drop Below Ground	360 mm (14 in.)
Blade	
Width	2.00 m (6 ft. 7 in.)
Height	375 mm (15 in.)
P Sprocket Center to Idler Center	2.00 m (6 ft. 7 in.)
Q Track Length	2.50 m (8 ft. 2 in.)
R Counterweight Clearance	610 mm (24 in.)

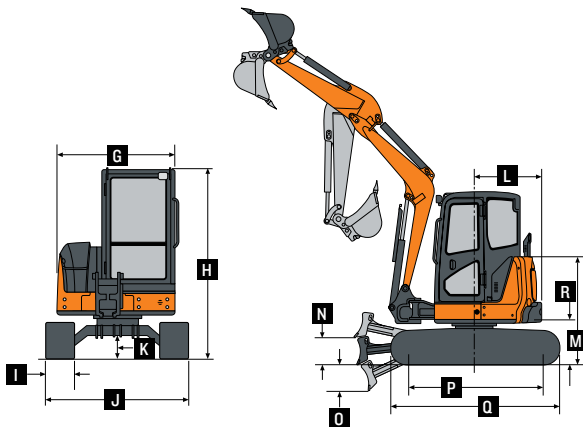
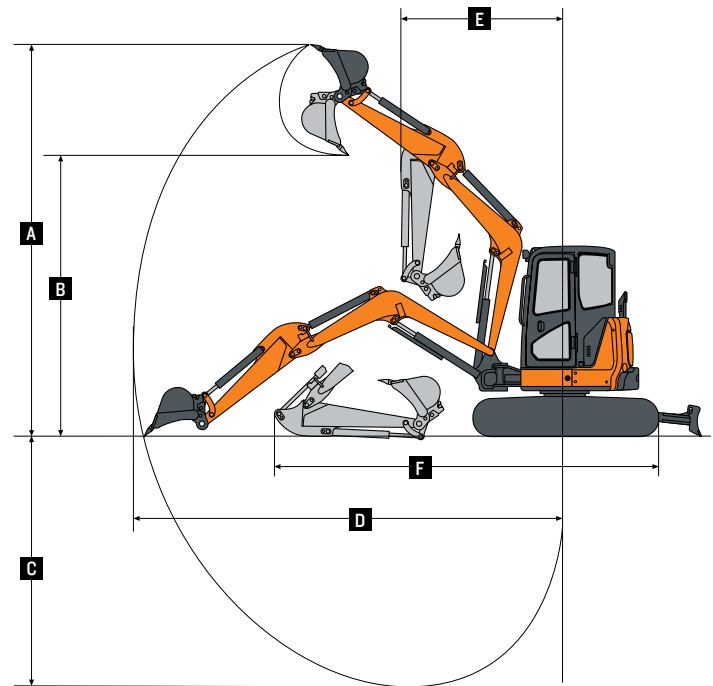

Lift Capacities

Ground Level at 3.05-m (10 ft.) Radius	Canopy and Standard Counterweight		Canopy and Extra Counterweight		Cab and Standard Counterweight		Cab and Extra Counterweight	
	Over Front*	Over Side	Over Front	Over Side	Over Front*	Over Side	Over Front*	Over Side
Arm 1380-mm (4 ft. 6 in.) Standard	2511 kg (5,531 lb.)	1110 kg (2,444 lb.)	2511 kg (5,531 lb.)	1232 kg (2,714 lb.)	2511 kg (5,531 lb.)	1150 kg (2,534 lb.)	2511 kg (5,531 lb.)	1273 kg (2,803 lb.)
1690-mm (5 ft. 7 in.) Long	2477 kg (5,456 lb.)	1088 kg (2,396 lb.)	2477 kg (5,456 lb.)	1210 kg (2,666 lb.)	2477 kg (5,456 lb.)	1129 kg (2,486 lb.)	2477 kg (5,456 lb.)	1251 kg (2,755 lb.)

*Blade down (limited by hydraulics).

Engine		ZX60USB-5		
Manufacturer and Model	Yanmar 4TNV98C			
Non-Road Emission Standard	EPA Final Tier 4/EU Stage IV			
Displacement	3.3 L (203 cu. in.)			
Net Power (ISO 9249)	39.6 kW (53 hp) at 2,000 rpm			
Powertrain				
Each track independently driven by hydrostatic axial-piston motor connected to 2-stage planetary gear-reduction box				
Maximum Travel Speed				
Low	2.9 km/h (1.8 mph)			
High	4.8 km/h (3.0 mph)			
Hydraulics				
Closed center load-sensing with 1 variable-displacement pump				
Pump Flow	144 L/m (38.0 gpm)			
Auxiliary Flow	92 L/m (24.2 gpm)			
Controls	Hydraulic pilot-operated controls for boom, arm, bucket, swing, boom swing, blade, travel and auxiliary functions			
Electrical				
Alternator Rating	55 amp			
Working Lights	2 halogen: 1 mounted on boom and 1 mounted on frame			
Undercarriage				
Track, Rubber	400 mm (16 in.)			
Ground Pressure	1500-mm (4 ft. 11 in.)		1850-mm (6 ft. 1 in.)	
	Standard Arm and Standard Counterweight		Long Arm and Extra Counterweight	
With Rubber Track	35 kPa (5.12 psi)		37 kPa (5.37 psi)	
Upperstructure				
Swing Speed	9.5 rpm			
Independent Swing Boom				
Left	80 deg.			
Right	60 deg.			
Swing Brake	Spring-applied, hydraulically released, automatic, disc type			
Serviceability				
Refill Capacities				
Fuel Tank	120 L (31.7 gal.)			
Cooling System	7.7 L (8.1 qt.)			
Engine Oil with Filter	11.2 L (11.8 qt.)			
Hydraulic Tank	80 L (21.1 gal.)			
Operating Weights				
	1500-mm (4 ft. 11 in.) Standard Arm, Standard Counterweight and Rubber Tracks	1500-mm (4 ft. 11 in.) Standard Arm, Standard Counterweight and Steel Tracks	1850-mm (6 ft. 1 in.) Long Arm, Extra Counterweight and Rubber Tracks	1850-mm (6 ft. 1 in.) Long Arm, Extra Counterweight and Steel Tracks
With 0.22-m ³ (7.8 cu. ft.) Bucket, Full Fuel Tank and 79-kg (175 lb.) Operator	6145 kg (13,547 lb.)	6245 kg (13,768 lb.)	6443 kg (14,204 lb.)	6543 kg (14,425 lb.)
Optional Angle Blade	458 kg (1,010 lb.)			
Counterweight				
Standard	745 kg (1,642 lb.)			
Additional	270 kg (595 lb.)			

Operating Dimensions	ZX60USB-5	
	1500-mm (4 ft. 11 in.) Standard Arm	1850-mm (6 ft. 1 in.) Long Arm
A Maximum Cutting Height	5.96 m (19 ft. 7 in.)	6.19 m (20 ft. 4 in.)
B Maximum Dumping Height	4.17 m (13 ft. 8 in.)	4.41 m (14 ft. 6 in.)
C Maximum Digging Depth	3.77 m (12 ft. 4 in.)	4.12 m (13 ft. 6 in.)
D Maximum Digging Reach	6.23 m (20 ft. 5 in.)	6.56 m (21 ft. 6 in.)
E Minimum Front Swing Radius	2.45 m (8 ft. 0 in.)	2.54 m (8 ft. 4 in.)
F Transport Length	5.76 m (18 ft. 11 in.)	5.90 m (19 ft. 4 in.)
Digging Force (ISO)		
Arm	31.1 kN (6,989 lb.)	27.0 kN (6,063 lb.)
Bucket	41.1 kN (9,237 lb.)	41.1 kN (9,237 lb.)

Machine Dimensions	
G Upperstructure Width	2.00 m (6 ft. 7 in.)
H Overall Height	2.54 m (8 ft. 4 in.)
I Track Width	400 mm (16 in.)
J Undercarriage Width	2.00 m (6 ft. 7 in.)
K Ground Clearance	340 mm (13 in.)
L Tail Swing Radius	
With Standard Arm	1.30 m (4 ft. 3 in.)
With Long Arm and Extra Counterweight	1.41 m (4 ft. 8 in.)
M Engine Cover Height	1.60 m (5 ft. 3 in.)
N Maximum Blade Lift Above Ground	460 mm (18 in.)
O Maximum Blade Drop Below Ground	370 mm (15 in.)
Blade	
Width	2.00 m (6 ft. 7 in.)
Height	420 mm (16 in.)
P Sprocket Center to Idler Center	1.99 m (6 ft. 6 in.)
Q Track Length	2.50 m (8 ft. 2 in.)
R Counterweight Clearance	620 mm (24 in.)

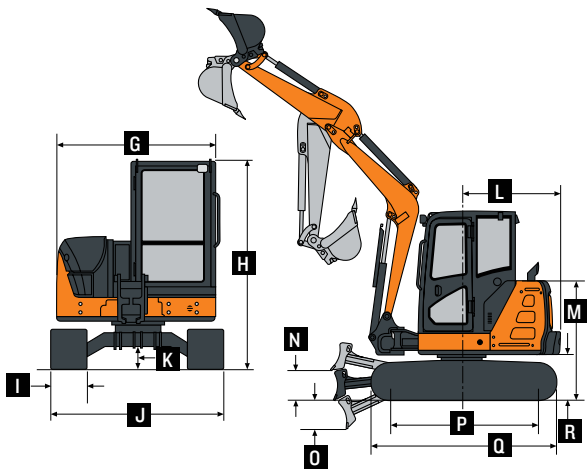
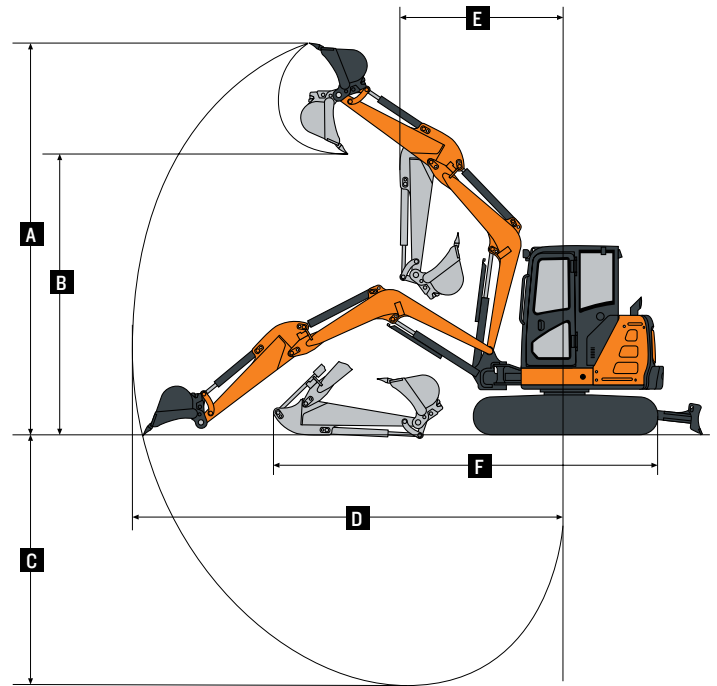

Lift Capacities	Standard Counterweight and Rubber Track		Standard Counterweight and Steel Track		Extra Counterweight and Rubber Track		Extra Counterweight and Steel Track	
	Over Front*	Over Side	Over Front*	Over Side	Over Front*	Over Side	Over Front*	Over Side
Ground Level at 3.05-m (10 ft.) Radius								
Arm								
1500-mm (4 ft. 11 in.) Standard	3785 kg (8,345 lb.)	1463 kg (3,225 lb.)	3785 kg (8,345 lb.)	1490 kg (3,284 lb.)	3785 kg (8,345 lb.)	1657 kg (3,652 lb.)	3785 kg (8,345 lb.)	1683 kg (3,711 lb.)
1850-mm (6 ft. 1 in.) Long	3719 kg (8,198 lb.)	1444 kg (3,184 lb.)	3719 kg (8,198 lb.)	1471 kg (3,243 lb.)	3719 kg (8,198 lb.)	1638 kg (3,612 lb.)	3719 kg (8,198 lb.)	1665 kg (3,671 lb.)

*Blade down (limited by hydraulics).



ADDITIONAL EQUIPMENT

Key: ● Standard ▲ Optional or special

35	50	60	Engine
●	●	●	Meets EPA Final Tier 4/EU Stage IV emissions
●	●	●	Engine coolant to -37 deg. C (-34 deg. F)
●	●	●	Engine preheater
●	●	●	Fan guard
●	●	●	Fuel/water separator
●	●	●	Full-flow oil filter
●	●	●	Isolation mounted
●	●	●	Key start switch with electric fuel shutoff
●	●	●	Single dry-type air filter
			Hydraulic System
●	●	●	Auxiliary function right-hand pilot lever control
●	●	●	Auxiliary hydraulic lines with quick couplers to end of boom
●	●	●	Auxiliary return-flow selector valve
●	●	●	Axial piston swing motor
●	●	●	Boom-swing foot control
●	●	●	Excavator-to-backhoe control pattern change valve
●			Open center with 2 variable-displacement pumps and 1 fixed-gear pump
●	●	●	Closed center load-sensing with 1 variable-displacement pump
●	●	●	Hydraulic pilot-operated controls for boom, arm, bucket, swing, boom swing, blade, travel and auxiliary functions
●	●	●	Wet-disc swing brake
			Undercarriage
●	●	●	Planetary final drive
●	●	●	Propel motor shield
●	●	●	2-speed axial-piston propel motors
●	●	●	Rubber track, 300 mm (12 in.)
●	●	●	Rubber track, 400 mm (16 in.)
▲			Steel track, 300 mm (12 in.) with triple semi-grousers
▲	▲	▲	Steel track, 400 mm (16 in.) with triple semi-grousers
▲			Rubber crawler pad, 300 mm (12 in.)
▲	▲	▲	Rubber crawler pad, 400 mm (16 in.)

35	50	60	Upperstructure
●	●	●	360-deg. rotation
●			Counterweight, 540 kg (1,190 lb.)
●			Counterweight, 700 kg (1,543 lb.)
●	●	●	Counterweight, 745 kg (1,642 lb.)
●	●	●	Hinged service-access doors
●	●	●	Toolbox
●	●	●	ROPS/TOPS/FOPS canopy
▲	▲	●	ROPS/TOPS/FOPS (cab) with air conditioning and heater
●	●	●	Vandal protection for service doors, fuel cap and toolbox
●	●	●	Zero-tail-swing configuration
●	●	●	Reduced-tail-swing configuration
			Front Attachments
●			Arm, 1315 mm (4 ft. 4 in.)
●			Arm, 1380 mm (4 ft. 6 in.)
●			Arm, 1500 mm (4 ft. 11 in.)
▲			Long arm, 1690 mm (5 ft. 7 in.), includes additional 200-kg (595 lb.) counterweight
▲			Long arm, 1715 mm (5 ft. 8 in.), includes additional 240-kg (549 lb.) counterweight
▲			Long arm, 1850 mm (6 ft. 1 in.), includes additional 270-kg (595 lb.) counterweight
●	●	●	Articulation hose shield
●			Backfill blade, 1.74 m (5 ft. 9 in.)
●	●	●	Backfill blade, 2.00 m (6 ft. 7 in.)
▲	▲	▲	Hydraulic angle backfill blade
●			Boom, 2.465 m (8 ft. 1 in.)
●			Boom, 2.85 m (9 ft. 4.2 in.)
●	●	●	Boom, 2.965 m (9 ft. 9 in.)
●	●	●	Mechanical quick-coupler
▲	▲	▲	Augers: Planetary / Chain drive / Bits / Bit adapters
▲	▲	▲	Clamp
▲	▲	▲	Hammers: Points / Tools
▲	▲	▲	Quick-coupler buckets: Bucket teeth / Ditching / Heavy-duty

35	50	60	Operator's Station
●	●	●	Horn
●	●	●	Hour meter
●	●	●	Instrumentation lights
●	●	●	Monitor system: Preheat indicator / Engine-oil-pressure indicator with alarm / Alternator voltage indicator / Fuel gauge and low-fuel-level indicator / Engine-coolant-temperature gauge and engine coolant temperature indicator with alarm / Hour meter / Work lights indicator
●	●	●	Motion alarm with cancel switch
●	●	●	Work lights switch
●	●	●	Propel levers and foldable pedals
●	●	●	2 travel speeds with automatic shifting
●	●	●	Seat belt, 51 mm (2 in.), retractable
▲	▲	▲	Seat belt, 76 mm (3 in.), retractable
●	●	●	Vinyl seat with fore/aft adjustment
▲	▲	●	Suspension seat (cloth)
▲	▲	▲	Front screen
▲	▲	▲	Rear secondary exit kit
			Electrical
●	●	●	12-volt accessory outlet
●	●	●	Alternator, 55 amp
●	●	●	Low-maintenance battery
●	●	●	Blade-type multi-fused circuits
●	●	●	Positive-terminal battery covers
▲	▲	▲	ZXLink™ wireless communication system (available in specific countries; see your dealer for details)
			Lights
●	●	●	Work lights: Halogen / 1 mounted on operator's station / 1 mounted on boom

See your Hitachi dealer for further information.

Net engine power is with standard equipment including air cleaner, exhaust system, alternator and cooling fan at test conditions per ISO 9249. These machines are not equipped with spark-arrestor mufflers. Usage in forestry applications is not recommended. Specifications and design subject to change without notice. Wherever applicable, specifications are in accordance with SAE standards. Except where otherwise noted, these specifications are based on units with standard arms, full fuel tanks and 79-kg (175 lb.) operators; a ZX35U-5 canopy unit with 610-mm (24 in.), 0.11-m³ (4 cu. ft.) bucket, 300-mm (12 in.) rubber track and 540-kg (1,190 lb.) counterweight; a ZX50U-5 canopy unit with 610-mm (24 in.), 0.16-m³ (5.7 cu. ft.) bucket, 400-mm (16 in.) rubber track and 700-kg. (1,543 lb.) counterweight; a ZX60USB-5 cab unit with 0.19-m³ (6.8 cu. ft.) bucket, 400-mm (16 in.) rubber track and 745-kg (1,642 lb.) counterweight.

HITACHI

hitachiconstruction.com