

# 150-T



- power to lift.

# HMF T-Boom Range Loader 150-T

## The ideal Loader for lightweight Vehicles

- Good utilization of the vehicle payload
- Lifts 340 kg at 2.9 metres
- Easy and simple operation
- Requires minimum space on the body
- Large, efficient slewing area
- Electro-hydraulic power pack
- Built-in safety: load-holding valves on all cylinders

Loading group B2		150-T1	150-T2
Load moment	tm	1.0	1.0
Hydraulic reach	m	2.1	2.9
Slewing torque	kgm	55	55
Slewing angle	°	350	350
Height above chassis	mm	1485	1485
Width, folded	mm	540	540
Weight incl. 1 stabilizer and power pack	kg	160	170
Weight incl. M-base	kg	139	149
Working pressure	MPa	18.5	18.5
Pump performance	l/min	2.5-4	2.5-4
Separate electro-hydraulic pump	V	12/24	12/24
Power consumption	V	12	12
	amp	180	180
Power consumption	V	24	24
	amp	90	90

150-T1/T2

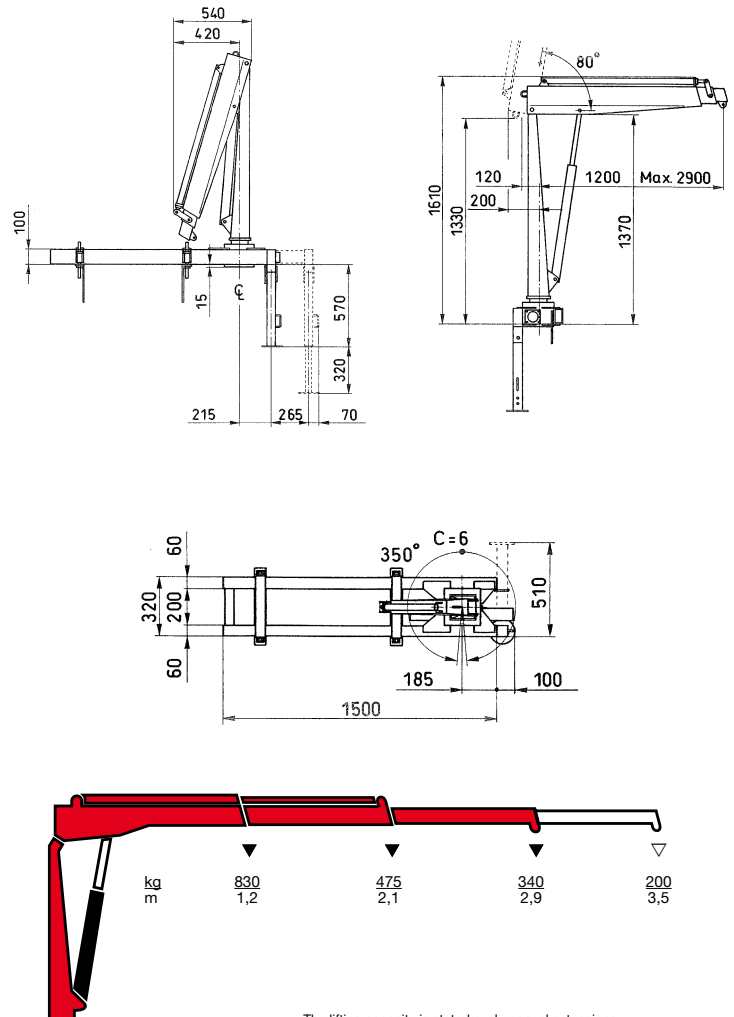
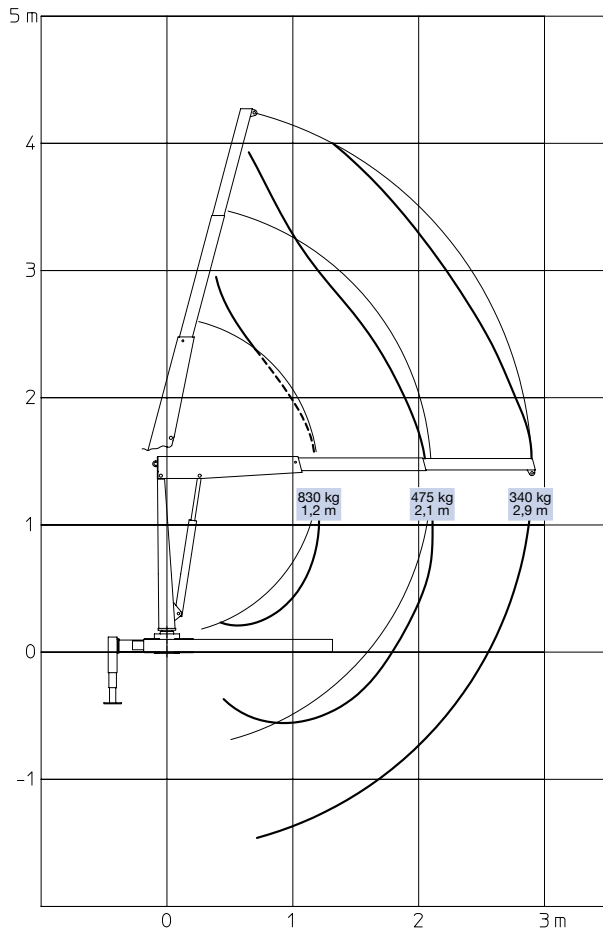

The lifting capacity is stated excl. manual extensions

Z008035-3

We reserve the right to introduce improvements and modifications



Højbjerg Maskinfabrik A/S • Oddervej 200 • DK-8270 Højbjerg  
Tel.: +45 8627 0800 • Fax: +45 8627 0744 • info@hmf.dk

[www.hmf.dk](http://www.hmf.dk)

Courtesy of Crane.Market