

# CC40

# Hydex

## Container Carrier Articulated Truck

The **HYDEX CC40** is designed for hauling 20ft ISO Containers.

Based on the Cat 740 Articulated Truck chassis offering proven reliability and durability, high class performance and productivity, optimum payload, operator comfort and ease of operation.



- Safety interlock
- Container corner guards
- Cab actuated twistlocks
- Light in cab to confirm lock engagement
- Optional hydraulic tailgate

### Engine Gross Power

350 kW	469 hp
--------	--------

### Engine Net Power (ISO)

342 kW	458 hp
--------	--------

### Operating Weight (loaded)

72 600 kg	160,055 lb
-----------	------------

### Rated Payload

42.3 tonne	46.6 tons
------------	-----------

The Hydex CC40 is supplied by **Articulated Truck Solutions LLP**

# CC40 Container Carrier Articulated Truck *Specifications*

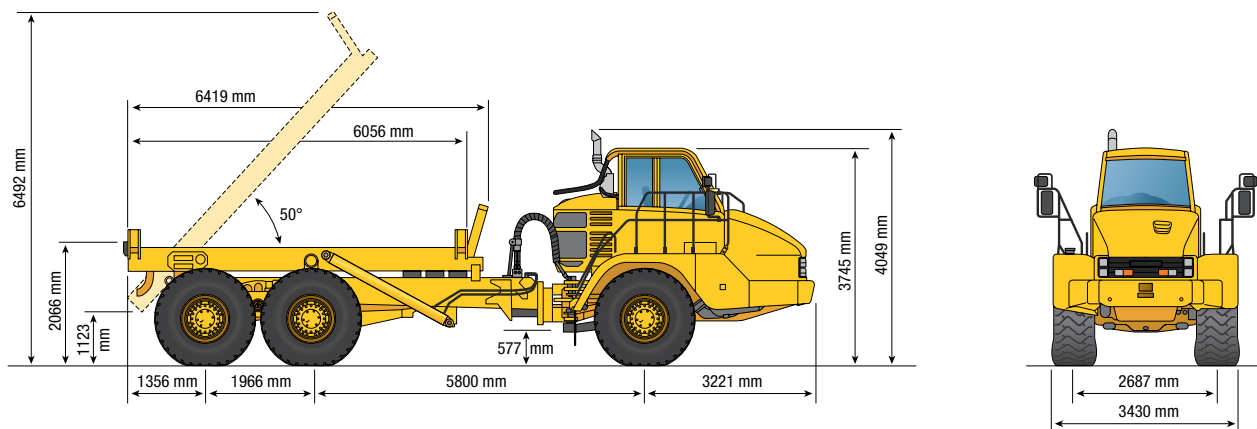

## Engine

Engine Model	Cat® C15 ACERT®	
Gross Power – SAE J1995	350 kW	469 hp
Net Power – SAE J1349	338 kW	453 hp
Net Power – ISO 9249	342 kW	458 hp
Net Power – EEC 80/1269	342 kW	458 hp
Bore	137 mm	5.4 in
Stroke	171.5 mm	6.75 in
Displacement	15.2 ltr	926 cu.in

## Transmission

Forward 1	8.9 km/h	5.5 mph
Forward 2	12.1 km/h	7.5 mph
Forward 3	16.4 km/h	10.2 mph
Forward 4	22 km/h	13.7 mph
Forward 5	30 km/h	18.6 mph
Forward 6	40 km/h	25.1 mph
Forward 7	54.7 km/h	34 mph
Reverse 1	8.4 km/h	5.2 mph
Reverse 2	11.6 km/h	7.2 mph

## Standards

Brakes	ISO 3450 : 1996
Cab/FOPS	ISO 3449 Level II : 2005
Cab/ROPS	ISO 3471 : 2008
Steering	ISO 5010 : 2007

## Operating Weights

Front Axle - Empty	19 400 kg	42,770 lb
Center Axle - Empty	7200 kg	15,873 lb
Rear Axle - Empty	6500 kg	14,330 lb
<i>Total Empty</i>	<i>33 100 kg</i>	<i>72,973lb</i>
Front Axle - Rated Load	5200 kg	11,464 lb
Center Axle - Rated Load	17 150 kg	37,809 lb
Rear Axle - Rated Load	17 150 kg	37,809 lb
<i>Total Rated Load</i>	<i>39 500 kg</i>	<i>87,083 lb</i>
Front Axle - Loaded	24 600 kg	54,234 lb
Center Axle - Loaded	24 350 kg	53,683 lb
Rear Axle - Loaded	23 650 kg	52,139 lb
<i>Total - Loaded</i>	<i>72 600 kg</i>	<i>160,055 lb</i>
Rated Payload	42.3 tonnes	46.6 tons

## Body Hoist

Raise Time	12 seconds
Lower Time	7 seconds

## Service Capacities

Fuel Tank	532 ltr	140.5 gal
Cooling System	80 ltr	21.1 gal
Hydraulic System	328 ltr	86.6 gal
Engine Crankcase	38 ltr	9.5 gal
Transmission	72 ltr	19 gal
Final Drives/Differential	72 ltr	19 gal
Output Transfer Gearbox	18 ltr	4.8 gal

## Sound Levels

Interior Cab	79 dB(A)
--------------	----------

All cab/chassis machine specifications are contained in the Cat 740 specalogue publication AEHQ6031

Materials and specifications are subject to change without notice.

See your Caterpillar dealer for standard and optional cab equipment.

## Articulated Truck Solutions LLP

CAT, CATERPILLAR, ACERT, their respective logos, "Caterpillar Yellow" and the POWER EDGE trade dress, as well as corporate and product identity used herein, are trademarks of Caterpillar and may not be used without permission.

### Head Office

Unit 30, Twyford Business Centre  
London Road, Bishop's Stortford  
Herts, CM23 3YT  
United Kingdom  
Tel: +44 (0)1279 755590  
Fax: +44 (0)1279 652644  
www.hydexuk.com