



Narrow-Aisle, Single & Double Reach, AC Powered Lift Trucks

N35-40ZRS/ N30ZDRS



STRONG PARTNERS. TOUGH TRUCKS.™

PRODUCTIVITY:

- AC hoist system maximizes lift at lower speeds
- AC traction system maximizes performance and provides seamless direction transitions
- Electric power steering, standard on all models, offers on-demand steering for maximum efficiency and minimal battery drain
- Automatic drive tire centering at start-up saves time for the operator
- Automatic brake operation applies the brake when the truck is stationary, eliminating the need for the operator to lift a leg to apply the brake
- Optional electrically steered caster

COST OF OPERATION:

- AC traction and hoist motors help reduce maintenance through a simpler design and the elimination of brush replacement
- Sealed load wheels bearings reduce greasing requirements
- Brushless steering and auxiliary motors reduce maintenance time and cost
- Electric brake provides parking and emergency braking capability with no need to service
- Dual articulating caster wheels promote even tire wear and minimize tire scrub

DEPENDABILITY:

- CANbus communication system reduces wiring and electrical connections and provides real time diagnostics
- Sealed electrical connectors keep out debris and help reduce the possibility of loose connections
- O-ring face seal fittings help maximize uptime and reduce leaks
- Completely brushless AC traction and hoist motors improve reliability
- Thermal management system for all motors and controllers add protection from overheating
- Dedicated auxiliary pump and motor helps reduce demand on main hydraulic motor

SERVICEABILITY:

- Daily operator checks can be performed without removing covers
- Full diagnostics are standard, easing serviceability, helping reduce troubleshooting time and vehicle downtime
- Easy access to all components for regular maintenance and repair
- Completely brushless traction, hoist and auxiliary function motors help reduce service time
- Regenerative braking helps reduce brake wear
- No need to remove the mast for adjustments

ERGONOMICS:

- *Drive-Rite Design Intent*
- Configuration flexibility with fore/aft and side stances available
- Large operator compartment and optimal operator position allow easy entry and exit without awkward twisting
- Low 9.6" step height helps reduce operator fatigue
- Brake pedal location and design is optimized for operator comfort
- Optional suspended floorplate cushions the operator and helps reduce stress on the operator's legs
- Adjustable steer tiller position
- Adjustable back with armrest
- On-demand electric power steering helps reduce operator effort

VERSATILITY:

- Multiple battery compartments are available:
 - 12.5", 14.5" and 16.5" for 3,500 and 4,000 lb. models
 - 14.5" and 16.5" for 3,000 lb. models
- Four programmable vehicle modes are available for maximum speed, acceleration, deceleration and hydraulic ramping
- Multi-function control handle integrated in armrest (side stance)



On-Demand Electric Steering:
Low effort reduces operator fatigue.

Mast: Adjustable wear strips help keep channel rails properly aligned. Mast removal and disassembly is not required for adjustments.

Configuration Flexibility:
Provides optimal operator positioning. Ability to select different stances (Fore/Aft or Side stance) and different control handle configurations.

Low Step Height: The 9.6" step height provides easy entry/exit to reduce operator fatigue.

Trucks shown with optional equipment.



DIMENSIONS

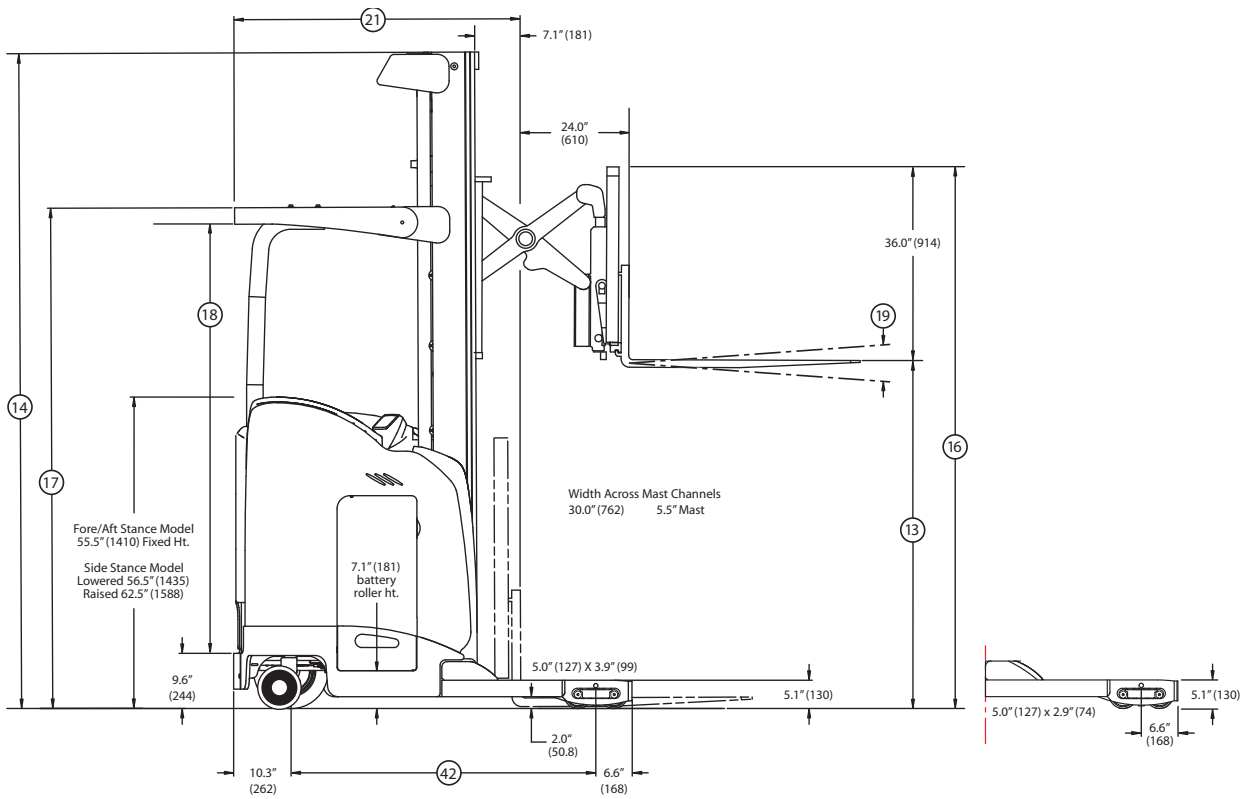
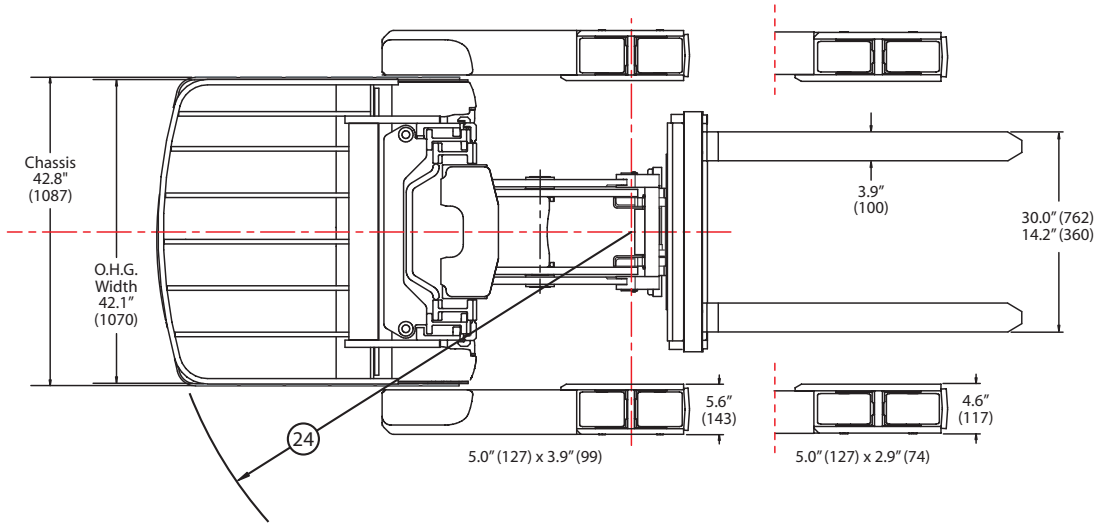

Circled dimensions correspond to the line numbers on the tabulated chart inside the Technical Guide. Dimensions are in inches (millimeters).

N35-40ZRS

N35-40ZRS SPECIFICATIONS

5

GENERAL	1	Manufacturer Name	Hyster Company		Hyster Company		Hyster Company		Hyster Company		
		2	Model	N35ZRS		N35ZRS		N40ZRS		N40ZRS	
3	Wheel Base Designation	SWB		SWB		SWB		SWB			
4	Rated Capacity	lb. (kg)	3500 (1588)		3500 (1588)		4000 (1814)		4000 (1814)		
5	Load Center, Distance	in. (mm)	24 (610)		24 (610)		24 (610)		24 (610)		
6	Power Type - Electric, Diesel, LPG		Electric - 24 volt		Electric - 36 volt		Electric - 24 volt		Electric - 36 volt		
7	Operator Type		Stand		Stand		Stand		Stand		
8	Tire Type - Load/Caster/Drive		Poly / Poly / Rubber		Poly / Poly / Rubber		Poly / Poly / Rubber		Poly / Poly / Rubber		
9	Wheels, Number Load/Drive (x=driven)		4 / 2 (1x)		4 / 2 (1x)		4 / 2 (1x)		4 / 2 (1x)		
WT.	10	Truck Weight, without Battery (approximate)	lb.	4950		4950		5000		5000	
	11			Front	Rear	Front	Rear	Front	Rear	Front	Rear
DIMENSIONS	12	Axle Loading - Front/Rear with Carriage Extended **	lb.	6750	3800	6750	3800	7400	3700	7400	3700
	13	Height, Standard Lift (TOF)	in. (mm)	See Mast Table		See Mast Table		See Mast Table		See Mast Table	
	14	Height, Standard mast Lowered (OALH)	in. (mm)								
	15	Height, Freelift (TOF)	in. (mm)								
	16	Height, Standard Mast Extended w/LBR	in. (mm)								
	17	Height, Top of OHG	in. (mm)								
	18	Height, Operator Clearance	in. (mm)	3 / 4		3 / 4		3 / 4		3 / 4	
	19	Mast Tilt Angle, Forward/Back	degrees°								
	20	Forks, Standard (Length x Width x Thickness)	in.								
	21	Headlength to Face of Forks - All Battery Compartments ***	in. (mm)	See Mast Table		See Mast Table		See Mast Table		See Mast Table	
	22	Basearm OEC	in.	34"- 49" (1" increments)		34"- 49" (1" increments)		34"- 49" (1" increments)		34"- 49" (1" increments)	
	23	Battery Compartment Size, 12.5" Battery Compartment - (LxWxH)	in.	39.0 x 12.5 x 31.5		39.0 x 12.5 x 31.5		39.0 x 12.5 x 31.5		39.0 x 12.5 x 31.5	
	Battery Compartment Size, 14.5" Battery Compartment - (LxWxH)	in.	39.0 x 14.5 x 31.5		39.0 x 14.5 x 31.5		39.0 x 14.5 x 31.5		39.0 x 14.5 x 31.5		
	Battery Compartment Size, 16.5" Battery Compartment - (LxWxH)	in.	39.0 x 16.5 x 31.5		39.0 x 16.5 x 31.5		39.0 x 16.5 x 31.5		39.0 x 16.5 x 31.5		
24	Turning Radius - minimum outside, 12.5" Battery Compartment	in.	65.74		65.74		65.74		65.74		
	Turning Radius - minimum outside, 14.5" Battery Compartment	in.	65.74		65.74		65.74		65.74		
	Turning Radius - minimum outside, 16.5" Battery Compartment	in.	67.74		67.74		67.74		67.74		
25	Aisle Width - Zero Clearance - Right Angle Stack	see chart	See "RAS" Table		See "RAS" Table		See "RAS" Table		See "RAS" Table		
PERFORMANCE	26	Stability - Comply with ANSI		Yes		Yes		Yes		Yes	
	28	Travel Speed, Rearward (chassis first) - Empty/RL	mph	6.5/6.5		6.7/6.5		6.5/6.5		6.7/6.5	
	29	Travel Speed, Forward (forks first) - Empty/RL	mph	6.5/6.5		6.7/6.5		6.5/6.0		6.7/6.0	
	31	Lift Speeds, Empty	ft./min	60		75		60		75	
	32	Lift Speeds, 2,000 lb.	ft./min	46		54		46		54	
	33	Lift Speeds, 3,000 lb.	ft./min	43		50		43		50	
	34	Lift Speeds, 3,500 lb.	ft./min	40		47		40		47	
	35	Lift Speeds, 4,000 lb.	ft./min	N/A		N/A		38		45	
	36	Lift Speeds, 4,500 lb.	ft./min	N/A		N/A		N/A		N/A	
	37	Lowering Speeds, Empty	ft./min	85		85		85		85	
38	Lowering Speeds, RL	ft./min	85		85		85		85		
WHEELS & TIRES	39	Size - Front Load Wheels, Standard		5 x 3.9		5 x 3.9		5 x 3.9		5 x 3.9	
	40			Drive	Caster	Drive	Caster	Drive	Caster	Drive	Caster
	41	Size, Standard - Drive Tire/Dual Casters		12.0 x 5.5 7.9 x 2.2		12.0 x 5.5 7.9 x 2.2		12.0 x 5.5 7.9 x 2.2		12.0 x 5.5 7.9 x 2.2	
	42	Wheelbase - 12.5" Battery Compartment	in.	55.35		55.35		55.35		55.35	
		Wheelbase - 14.5" Battery Compartment	in.	55.35		55.35		55.35		55.35	
		Wheelbase - 16.5" Battery Compartment	in.	57.36		57.36		57.36		57.36	
43	Brakes, Method of Control - Service/Parking		Foot		Foot		Foot		Foot		
44	Brakes, Method of Operation - Service/Parking		Spring Apply / Electric Release		Spring Apply / Electric Release		Spring Apply / Electric Release		Spring Apply / Electric Release		
ELECTRIC	45	Battery Type		Lead Acid		Lead Acid		Lead Acid		Lead Acid	
	46	Traction Motor Rating (60 minute rating)	hp (kw)	7.5 (5.6)		7.5 (5.6)		7.5 (5.6)		7.5 (5.6)	
	47	Hoist Motor Rating (5 minute rating)	hp (kw)	14.8 (11.0)		14.8 (11.0)		14.8 (11.0)		14.8 (11.0)	
	48	Traction Motor Control Method		Transistor		Transistor		Transistor		Transistor	
	49	Hoist Motor Control Method		Transistor		Transistor		Transistor		Transistor	
	50	Number of Speeds		Infinitely Variable		Infinitely Variable		Infinitely Variable		Infinitely Variable	

SWB = Short Wheel Base

** Static with Rated Load and Max. Wt. Battery

*** Add 1" for Sideshift

CERTIFICATION: These Hyster lift trucks meet design specifications of Part II ANSI B56.1-1969, as required by OSHA Section 1910.178(a)(2) and also comply with Part III ANSI B56.1-revision in effect at time of manufacture. Certification of compliance with the applicable ANSI standards appears on the lift truck.

NOTE: Performance specifications / ratings are for truck equipped as described under Standard Equipment in this Technical Guide. Performance specifications are affected by the condition of the vehicle and how it is equipped, as well as by the nature and condition of the operating area. Specifications are subject to change and the proposed application should be discussed with your authorized Hyster Dealer.

DIMENSIONS

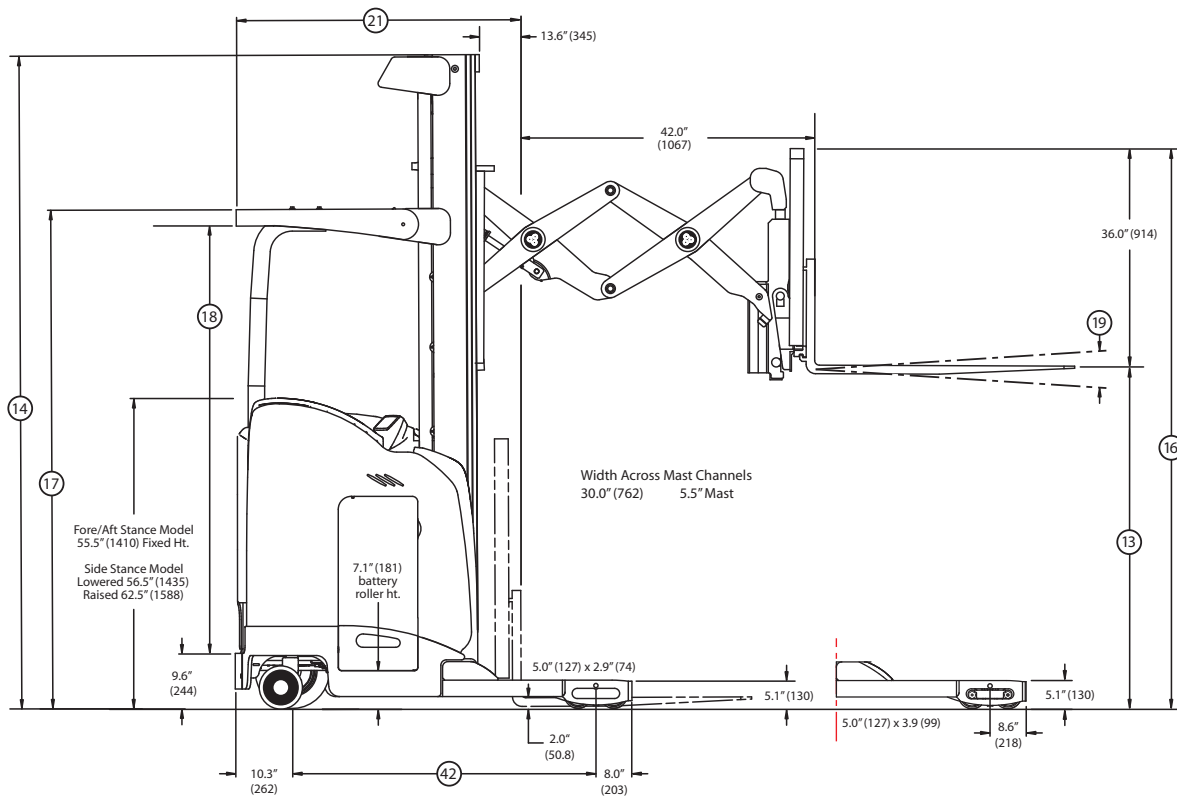
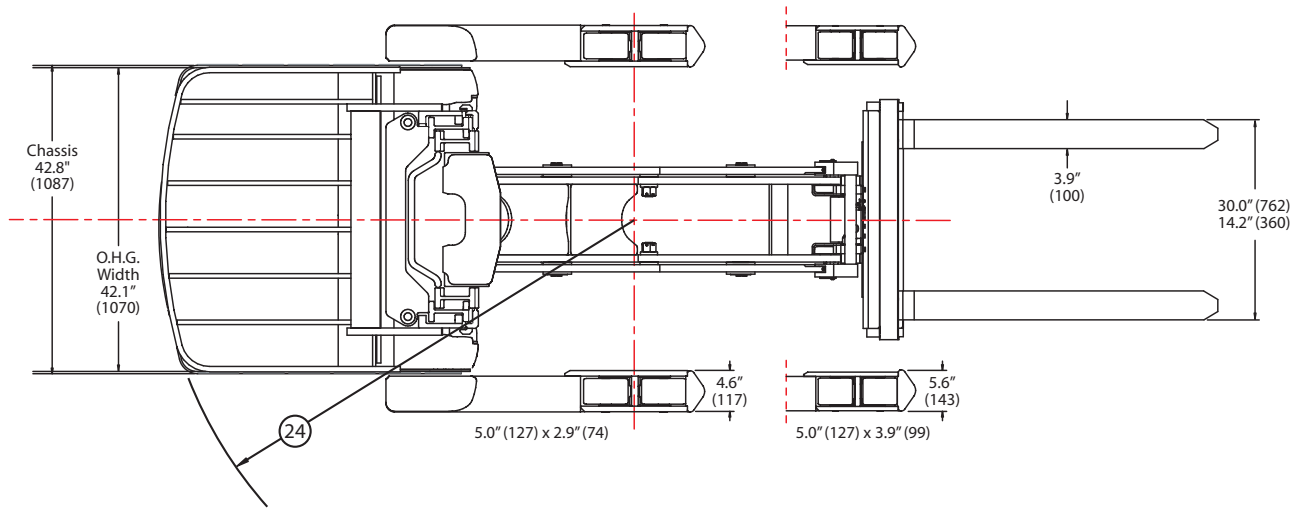

Circled dimensions correspond to the line numbers on the tabulated chart inside the Technical Guide. Dimensions are in inches (millimeters).

N30ZDRS

N30ZDRS SPECIFICATIONS

7

		GENERAL		WT.		
1	Manufacturer Name		Hyster Company		Hyster Company	
2	Model		N30ZDRS		N30ZDRS	
3	Wheel Base Designation		LWB		LWB	
4	Rated Capacity	lb. (kg)	3000 (1361)		3000 (1361)	
5	Load Center, Distance	in. (mm)	24 (610)		24 (610)	
6	Power Type - Electric, Diesel, LPG		Electric - 24 volt		Electric - 36 volt	
7	Operator Type		Stand		Stand	
8	Tire Type - Load/Caster/Drive		Poly / Poly / Rubber		Poly / Poly / Rubber	
9	Wheels, Number Load/Drive (x=driven)		4 / 2 (1x)		4 / 2 (1x)	
10	Truck Weight, without Battery (approximate)	lb.	5250		5250	
11			Front	Rear	Front	Rear
12	Axle Loading - Front/Rear with Carriage Extended **	lb.	6300	4050	6300	4050
13	Height, Standard Lift (TOF)	in. (mm)				
14	Height, Standard mast Lowered (OALH)	in. (mm)				
15	Height, Freelif (TOF)	in. (mm)				
16	Height, Standard Mast Extended w/LBR	in. (mm)				
17	Height, Top of OHG	in. (mm)				
18	Height, Operator Clearance	in. (mm)				
19	Mast Tilt Angle, Forward/Back	degrees°	3 / 4		3 / 4	
20	Forks, Standard (Length x Width x Thickness)	in.	1.6 x 3.9 x 42		1.6 x 3.9 x 42	
21	Headlength to Face of Forks - All Battery Compartments ***	in. (mm)	See Mast Table		See Mast Table	
22	Basearm OEC	in.	34"- 49" (1" increments)		34"- 49" (1" increments)	
23	Battery Compartment Size, 12.5" Battery Compartment - (LxWxH)	in.	N/A		N/A	
	Battery Compartment Size, 14.5" Battery Compartment - (LxWxH)	in.	39.0 x 14.5 x 31.5		39.0 x 14.5 x 31.5	
	Battery Compartment Size, 16.5" Battery Compartment - (LxWxH)	in.	39.0 x 16.5 x 31.5		39.0 x 16.5 x 31.5	
24	Turning Radius - minimum outside, 12.5" Battery Compartment	in.	N/A		N/A	
	Turning Radius - minimum outside, 14.5" Battery Compartment	in.	70.74		70.74	
	Turning Radius - minimum outside, 16.5" Battery Compartment	in.	72.74		72.74	
25	Aisle Width - Zero Clearance - Right Angle Stack	see chart	See "RAS" Table		See "RAS" Table	
26	Stability - Comply with ANSI		Yes		Yes	
28	Travel Speed, Rearward (chassis first) - Empty/RL	mph	6.5/6.5		6.7/6.7	
29	Travel Speed, Forward (forks first) - Empty/RL	mph	6.5/6.5		6.7/6.7	
31	Lift Speeds, Empty	ft./min	60		75	
32	Lift Speeds, 2,000 lb.	ft./min	44		51	
33	Lift Speeds, 3,000 lb.	ft./min	40		47	
34	Lift Speeds, 3,500 lb.	ft./min	N/A		N/A	
35	Lift Speeds, 4,000 lb.	ft./min	N/A		N/A	
36	Lift Speeds, 4,500 lb.	ft./min	N/A		N/A	
37	Lowering Speeds, Empty	ft./min	85		85	
38	Lowering Speeds, RL	ft./min	85		85	
39	Size - Front Load Wheels, Standard		5 x 2.9		5 x 2.9	
40			Drive	Caster	Drive	Caster
41	Size, Standard - Drive Tire/Dual Casters		12.0 x 5.5	7.9 x 2.2	12.0 x 5.5	7.9 x 2.2
42	Wheelbase - 12.5" Battery Compartment	in.	N/A		N/A	
	Wheelbase - 14.5" Battery Compartment	in.	60.35		60.35	
	Wheelbase - 16.5" Battery Compartment	in.	62.36		62.36	
43	Brakes, Method of Control - Service/Parking		Foot		Foot	
44	Brakes, Method of Operation - Service/Parking		Spring Apply / Electric Release		Spring Apply / Electric Release	
45	Battery Type		Lead Acid		Lead Acid	
46	Traction Motor Rating (60 minute rating)	hp (kw)	7.5 (5.6)		7.5 (5.6)	
47	Hoist Motor Rating (5 minute rating)	hp (kw)	14.8 (11.0)		14.8 (11.0)	
48	Traction Motor Control Method		Transistor		Transistor	
49	Hoist Motor Control Method		Transistor		Transistor	
50	Number of Speeds		Infinitely Variable		Infinitely Variable	

LWB = Long Wheel Base

** Static with Rated Load and Max. Wt. Battery

CERTIFICATION: These Hyster lift trucks meet design specifications of Part II ANSI B56.1-1969, as required by OSHA Section 1910.178(a)(2) and also comply with Part III ANSI B56.1-revision in effect at time of manufacture. Certification of compliance with the applicable ANSI standards appears on the lift truck.

NOTE: Performance specifications / ratings are for truck equipped as described under Standard Equipment in this Technical Guide. Performance specifications are affected by the condition of the vehicle and how it is equipped, as well as by the nature and condition of the operating area. Specifications are subject to change and the proposed application should be discussed with your authorized Hyster Dealer.

MAST DIMENSIONS AND BATTERY SPECIFICATIONS

MAST DIMENSIONS (5.5" STANDARD DUTY)

Maximum Fork Ht. (TOF) in. (mm)	Overall Lowered Height in. (mm)	Overall Height (Mast Extended) Highest Point w/ 36" Load Backrest in. (mm)	Free-Lift (TOF) in. (mm)	Overhead Guard Height to Top in. (mm)	Operator Clearance in. (mm)	Head Length (Length to Face of Forks)			
						12.5", 14.5" B.C.		16.5" B.C.	
						Single Reach	Double Reach	Single Reach	Double Reach
3-STAGE FULL FREE-LIFT (FFL) VISTA® MAST									
191 (4851)	87 (2210)	230 (5842)	48 (1219)	86.5 (2197)	75.3 (1913)	52.12	58.02	54.12	60.02
203 (5156)	91 (2311)	242 (6147)	52 (1321)	90.5 (2299)	79.3 (2014)	52.12	58.02	54.12	60.02
212 (5385)	95 (2413)	251 (6375)	56 (1422)	94.5 (2400)	83.3 (2116)	52.12	58.02	54.12	60.02
227 (5766)	101 (2565)	266 (6756)	62 (1575)	91 (2311)	79.8 (2027)	52.12	58.02	54.12	60.02
242 (6147)	107 (2718)	281 (7137)	68 (1727)	91 (2311)	79.8 (2027)	52.12	58.02	54.12	60.02
251 (6375)	110 (2794)	290 (7366)	71 (1803)	91 (2311)	79.8 (2027)	52.12	58.02	54.12	60.02
272 (6909)	119 (3023)	311 (7899)	80 (2032)	91 (2311)	79.8 (2027)	52.12	58.02	54.12	60.02

Right Angle Aisle Stacking

Note: These are "Zero Clearance" aisles and require an additional 6" or more to be added to provide for easier maneuvering.

N35/40ZRS					
Truck with 12.5" or 14.5" Battery Compartment and 42" ID					
3 Stage - 4" Between Loads					
Pallet Length (inches)	Pallet Width (inches)				
		36	40	44	48
	36	85	85	85	85
	40	87	87	86	86
	44	92	91	91	90
48	96	96	95	95	

Add 2" for 16.5" Battery Compartment; Add 1" for Sideshift

N30ZDRS					
Truck with 14.5" Battery Compartment and 42" ID					
3 Stage - 4" Between Loads					
Pallet Length (inches)	Pallet Width (inches)				
		36	40	44	48
	36	90	90	90	90
	40	91	91	91	91
	44	95	94	94	93
48	99	99	98	98	

Add 2" for 16.5" Battery Compartment; Sideshift is Standard on Double Reach

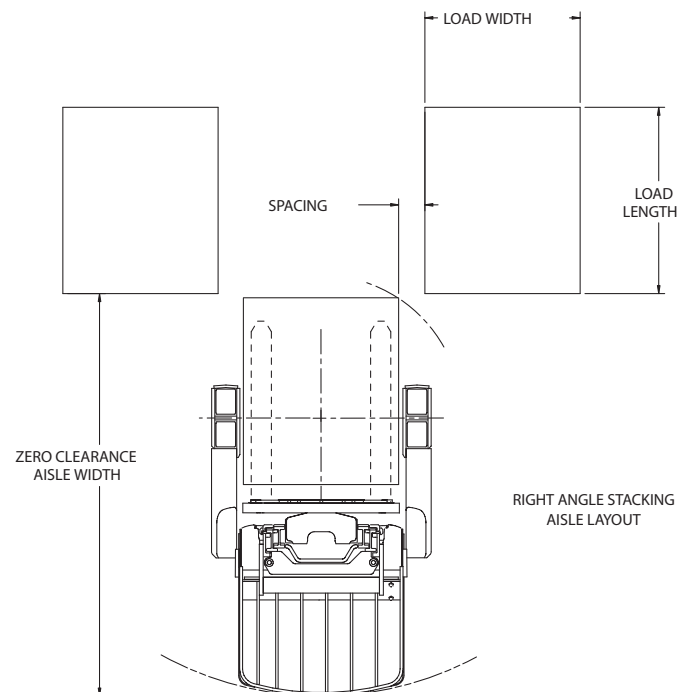

Battery and Compartment Specifications

Battery Specifications											
Battery Compartment Size	Battery Voltage	Maximum 6 Hr Rate		Battery Dimensions						Minimum Batt. Wt. lb. (kg)	Maximum Batt. Wt. lb. (kg)
		AH	KWH	"X" Max.		"Y" Max.		"Z" Max.			
				in.	(mm)	in.	(mm)	in.	(mm)		
12.5"	24	1085	25.4	38.8	(985)	12.25	(311)	31.0	(788)	1400 (635)	1900 (862)
14.5"	24	1240	29.0	38.8	(985)	14.25	(362)	31.0	(788)	1600 (726)	2100 (953)
14.5"	36	775	27.2	38.8	(985)	14.25	(362)	31.0	(788)	1600 (726)	2100 (953)
16.5"	24	1395	32.6	38.8	(985)	16.25	(413)	31.0	(788)	1850 (839)	2350 (1066)
16.5"	36	930	32.6	38.8	(985)	16.25	(413)	31.0	(788)	1850 (839)	2350 (1066)

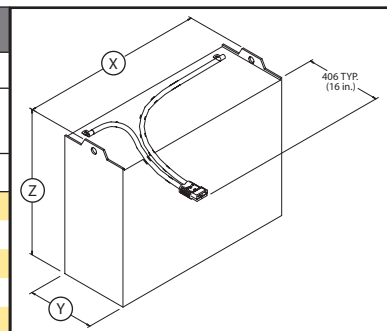

Battery Compartment is designed to accommodate standard wet cell batteries with fixed lifting eyes and no cover.
 Contact Applications Engineering to verify compatibility / fit when using maintenance free, covered or non-standard batteries.
 Battery Connector: 24V - Red; 36V - Gray; Position "B", Lead Length 16"
 Manufacturers Standard Cable Size Not to Exceed 4/0 AWG

STANDARD EQUIPMENT

- Fore/Aft Stance Operator Controls
- 24 Volt Battery (Includes 350 Amp Red Battery Connector)
- 91" / 203" / 52" – 3 Stage Full Free Lift Mast
- Single Reach Mast (24" Extend) with 33.5" Wide Class II Hook Type Carriage (Standard on N35ZRS and N40ZRS)
- Double Reach Mast (42" Extend) with 33.5" Wide Class II Hook Type Carriage (Standard on N30ZDRS)
- Forks: 1.8" x 3.9" (45 mm x 100 mm) 42" (1067 mm) – Class II Hook Type (Standard on N40ZRS)
- Forks: 1.6" x 3.9" (40 mm x 100 mm) 42" (1067 mm) – Class II Hook Type (Standard on N30ZDRS and N35ZRS)
- 5" x 3.9" Poly Articulating Tandem Load Wheels - High Load Compound (Standard on N35ZRS and N40ZRS)
- 5" x 2.9" Poly Articulating Tandem Load Wheels - High Load Compound (Standard on N35ZRS)
- Integral Sideshift for Standard 33.5" Wide Carriage- 7" Total Sideshift Travel (Standard on N30ZDRS)
- AC Traction, Lift / Lower and Steering
- Fully Integrated CANbus Controls
- Low Step Height
- Transistor Controller with Regenerative Braking
- Fully Proportional Lift/Lower Control
- Programmable Traction Speed and Acceleration
- Electric Power Steering
- Automatic Field Control and Auto Deceleration
- Rubber Drive Tire - 12.0" x 5.5"
- Dual Articulating Polyurethane Caster Wheels
- Emergency Power Disconnect
- Battery Discharge Indicator with Lift Interrupt
- Key Start
- 36" High Load Backrest Extension
- Sealed Battery Rollers
- Tilting Carriage (3° Fwd, 4° Back)
- Padded Operator Compartment
- Rear Post Operator Protection
- Operator's Overhead Guard
- Low Profile Anti-Fatigue Floormat
- Operator's Display with Alpha Numeric Messaging
- Multi-Mode Hour Meter
- Control Handle with Simultaneous Hydraulic Functions
- Electronic Horn
- Static Discharge Strap
- Operator's Manual
- UL Classification E

OPTIONAL EQUIPMENT

- Side Stance Operator Controls
- Reverse Steering
- Steered Caster - Electric
- Keyless Start
- Premium Display
- 36 Volt Battery (Includes 350 Amp Gray Battery Connector)
- Battery Stand
- Battery Puller
- Cooler/Freezer Construction (0° F to 120° F)
- Various-Sized Load Wheels with Sealed Bearings
- Tapered Basearm
- Poly Siped Drive Tires
- Lift Limits
- Various Fork Lengths
- Fork Height Display
- 48" High Load Backrest Extension
- Audible Back-up and Motion Alarms
- Rear Operator Compartment Door
- Audible Motion Alarm
- Visual Amber Strobe Light
- Operator Desktop Light
- Dual Headlight
- Rear Worklight
- Operator Overhead Fan
- Load Weight Display
- Reduced Travel Speed with Carriage Extended
- RF Terminal Bracket
- RF Handheld Scanner Holder
- Impact Monitor
- Parts Manual

N35-40ZRS/N30ZDRS

CAPACITY:

Model N30ZDRS: 3,000 lbs. at 24.0" (1,361 kg at 610 mm) load center.

Model N35ZRS: 3,500 lbs. at 24.0" (1,588 kg at 610 mm) load center.

Model N40ZRS: 4,000 lbs. at 24.0" (1,814 kg at 610 mm) load center.

RATED CAPACITIES ARE FOR TRUCKS EQUIPPED WITH:

- 3-Stage full free-lift (FLL) VISTA® mast to maximum fork height of 203" (5156 mm)
- 33.5" (851 mm) wide hook-type carriage, single reach (24.0" extend) with 42.0" (1067 mm) long forks
- 33.5" (851 mm) wide hook-type carriage, double reach (42.0" extend) with 42.0" (1067 mm) long forks
- 36.0" high load backrest extension (LBE)
- 1.8" x 3.9" (45 mm x 100 mm) 42" (1067 mm) long forks [N40ZRS]
- 1.6" x 3.9" (40 mm x 100 mm) 42" (1067 mm) long forks [N35ZRS and N30ZDRS]
- 5" x 3.9" poly articulating tandem load wheels [N35ZRS and N40ZRS]
- 5" x 2.9" poly articulating tandem load wheels [N30ZDRS]

MASTS

Models are equipped with a 5.5" 3-stage FFL mast assembly. The mast is constructed with the nested channel VISTA® design with full-face, straight load rollers. Brass side thrust plugs allow easy mast adjustment during periodic maintenance without removal or disassembly of mast.

CARRIAGE

The single reach mechanisms provide 24 inches of extension. The double reach mechanisms provide 42 inches of extension. Tilt function provides 4 degrees back tilt and 3 degrees forward tilt on both carriages. Sideshift is optional on single reach mechanisms. Double reach mechanism is offered with sideshift feature. Integral sideshift allows seven total inches of sideshift and is reduced to 3 inches total with OEC less than 39 inches.

The pantograph (reach mechanism) arms are all made from one-inch thick alloy steel. The inner arm weldments have additional gusset plates for added strength and rigidity. The main pantograph pivots use tapered roller bearings which provide a stiffer pivot joint. The reach mechanism hoses and wires are installed in a plastic cable carrier. The cable carrier secures wires and hose inside and provides positive routing for both. Sealed connectors are used throughout the mechanism.

FORKS

All fork assemblies are all hook type forks.

N35ZRS and N40ZRS

1.8" x 3.9" x 36", 42", 48"

(45 mm x 100 mm x 914 mm, 1067 mm, or 1219 mm)

N30ZDRS

1.6" x 3.9" x 36", 42", 48"

(40 mm x 100 mm x 914 mm, 1067 mm, or 1219 mm)

ELECTRICAL SYSTEM

The state-of-the-art electrical system features a CANbus communication network linking all vehicle systems. The Vehicle System Manager is an electronic module with an integral microprocessor that controls input and output capabilities. The vehicle application software monitors operator inputs and vehicle performance. The software adjusts vehicle performance as needed to improve the operation of the truck.

Hand controls, which are positioned to optimize each stance configuration, include the multi-function handle, steer tiller assembly, dash display, key switch and emergency stop switch.

The Fore/Aft stance multi-function handle utilizes a single pivot axis for traction control, and thumb actuated controls for lift/lower operation. The handle provides simultaneous operation of traction, lift/lower, and reach functions. Additionally, the handle is utilized in rearward travel and provides traction and horn operation.

The Side stance multi-function control handle assembly offers palm rest and large function buttons. The handle allows simultaneous operation of traction, lift/lower, and one auxiliary function.

STEERING SYSTEM

Electric on-demand power steering
Auto-centering at start-up
Adjustable lock to lock
Adjustable tiller force feedback
Speed sensitive power assist
Electronic adjustment of steer modes for automotive or reverse steering

BATTERY

The steel battery compartment provides secure storage and provides battery access / service from either side of the truck.

Equipped with corrosion resistant, ball bearing battery rollers, battery installation or removal is a quick and easy process.

HYDRAULIC SYSTEM

The AC hydraulic system features proportional lifting and lowering. The lift function is controlled by varying lift motor RPM, which maximizes system efficiency. By utilizing the lift motor RPM to control oil flow, pressure drop in the lift hydraulic lines is minimized. The lower function is controlled by a proportional control valve which provides excellent lowering speed control.

The lift motors are highly reliable AC designs featuring a Class F insulation rating. The motors have speed and temperature sensors mounted internally. The temperature sensor protects the motor from overheating. The speed sensor provides feedback to the hoist controller for precise speed control.

DRIVE TRAIN

The AC traction system offers excellent acceleration, deceleration or regenerative braking and seamless, smooth transitions during plugging.

The plugging function is variable according to the handle position. All deceleration is performed by regenerative braking through the vehicle control system. Regenerative braking puts vehicle kinetic energy back into battery, improving efficiency, and reducing wear on brake components.

Four operator selectable drive modes are available: rabbit, battery saver, mid, and turtle. Rabbit mode provides maximum acceleration and travel speeds. The battery saver mode provides high travel speeds at reduced acceleration. Mid mode reduces travel speeds and acceleration further. Turtle mode reduces travel speed by 50% and also limits acceleration.

BRAKE

A spring applied, electrically released brake is standard on all models.

The brake is pre-adjusted and requires no servicing. Regenerative braking is standard. When the motor RPM reaches 200, the brake is activated.

The brake pedal mounting location is optimized for each stance allowing comfortable operation by a wide range of operators. The switch mounting locations require the operator to be within the operator compartment in normal operator position prior to enabling operation of vehicle traction and hoist systems.

OPERATOR COMPARTMENT

Two operator compartments are offered, Fore/Aft stance and Side stance. The operator's *Drive Rite Design Intent* compartment is ergonomically designed to provide operators with excellent visibility, efficiency and productivity.

Operator controls are positioned for optimum productivity and comfort on both Fore/Aft stance and Side stance with standard adjustable steer tiller.

Low 9.6 inch step height, combined with a wide entrance opening into the operator compartment, provides comfortable entry and exit from the truck.

Compartments have room for the operator to vary their stances and include a floating floor plate design with an ergonomically shaped floor mat for excellent ride comfort and reduced body fatigue.

Both the brake and operator sensing switch are mounted below the floor mat, providing unobstructed entry and exit from the truck.

Operator compartments are fully padded for comfort and as a thermal insulator from drive compartment heat.

The Side stance compartment provides a large backrest pad with integral lumbar and armrest support with optional vertical adjustment for a wide range of operator heights.

Doors are intended to protect the operator from objects that may enter the operator's compartment but they may also slow the operator's egress in emergency situations. A review of the forklift's intended environment should be conducted before selecting a door as optional equipment.





FLEET SERVICES



HYSTER CAPITAL

A Division of NMHG Financial Services, Inc.

It's not just about the lift trucks.

Any company worth its weight knows success has just as much to do with the support before and after the sale as the sale itself. We pride ourselves on being more than just a lift truck manufacturer. Through our Dealer Network, we're also fleet managers, parts suppliers, capital procurement specialists and trainers. You'll find that when it comes to service, we do it all.

Hyster Fleet Services

As much as we'd like for your entire fleet to be Hyster, we know that's not always the case. But just because you also operate other brands doesn't mean we can't manage your lift truck maintenance and replacement plan. We can analyze your current fleet or provide summary of your fleet history and a cost-effective proposal for replacement and scheduled maintenance of all your vehicles. Once this initial review is complete, we'll continue to monitor your fleet to ensure it's performing optimally.

UNISOURCE™ Parts Program

In addition to providing fleet management for a variety of brands, we can also serve as your source of parts for all your lift trucks. With the Hyster UNISOURCE parts and service program, we offer approximately 2 million part number crosses for most brands of materials handling and other in-plant mobile equipment. UNISOURCE also has remanufactured parts that provide the same quality and guarantee but at a lower price. And we can deliver parts to you in less than 24 hours, any day of the week. How's that for convenience?

Rental Products

At Hyster Company, we're always looking for ways to help you keep your productivity up. Through the Hyster Dealer Network, you can access rental equipment for the times when leasing or buying isn't a practical option. Your local Hyster Dealer has access to over 14,000 units that are available for short- or long-term rental. Whether you need one truck to substitute for a vehicle that's being serviced or several lift trucks to accommodate seasonal changes in your business, we'll help you maintain output in a cost-effective manner.

Hyster Capital

We know that financing new additions to your fleet can sometimes be challenging. That's why your Hyster Dealer has a long list of ways for you to fund your purchase. We are skilled in arranging solutions for special financing requirements, taking the difficulties out of buying the equipment you need. Whether you purchase or lease a new or used lift truck, Hyster Capital offers better service and competitive rates, ensuring you receive the value you deserve.

Special Products Engineering Department (SPED)

In a perfect world, every application could be handled with a standard lift truck. However, in the real world, different materials require different handling. That's why Hyster Company's Special Products Engineering Department works with you to customize* your lift trucks. From strobe lights to specially made forks, SPED can provide you with the tools you require to get the job done right.

** May be subject to an additional charge. Contact your local authorized Hyster Dealer for more information.*

Automated Warehouse Solutions

As society's technological capabilities advance, we strive to find practical applications. One of our most recent innovations in that pursuit is our development of automated warehouse solutions. We can help you determine if your operation would benefit from this type of system, which improves inventory accuracy, warehouse productivity and safety records, as it reduces maintenance and overtime.

Operator and Service Training



Hyster Company recognizes that proper training is a key element of a profitable company. That's why your local authorized Hyster Dealer offers a training program for your lift truck operators as well as those who maintain your vehicles. Proper education in running and servicing lift trucks cuts down on the number of repairs and risk of injuries due to accidents while increasing productivity. All of our trainers are professionals with experience in materials handling.





Hyster Company
P.O. Box 7006
Greenville, North Carolina
27835-7006
Part No. N35-40ZRS/N30ZDRS
BTG 7/2007 Litho in U.S.A.

**Visit us online at www.hysteramericas.com
or call us at 1-800-HYSTER-1.**

 is a registered trademark of Hyster Company. Hyster and  are trademarks of Hyster Company. Hyster products are subject to change without notice.

Truck on cover shown with optional equipment.
©2006 Hyster Company. All rights reserved.

