

STANDARD EQUIPMENT

ISO Standard cabin

All-weather steel cab with 360° visibility
Safety glass windows
Rise-up type windshield wiper
Sliding fold-in front window
Sliding side window(LH)
Lockable door
Hot & cool box
Storage compartment & Ashtray
Radio & USB player
Handsfree mobile phone system with USB
Transparent cabin roof-cover
12 volt power outlet (24V DC to 12V DC converter)
Sun visor

Cabin ROPS(ISO 12117-2)

ROPS(Roll over protective structure)

Computer aided power optimization (New CAPO) system

3-power mode, 2-work mode, User mode
Auto deceleration & one-touch deceleration system
Auto warm-up system
Auto overheat prevention system

Automatic climate control

Air conditioner & heater
Defroster

Self-diagnostics system

Starting Aid (air grid heater) for cold weather

Centralized monitoring

LCD display
Engine speed or Trip meter/Accel.
Clock
Gauges
Fuel level gauge
Engine coolant temperature gauge
Hyd. oil temperature gauge
Warnings
Check engine
Overload
Communication error
Low battery
Air cleaner clogging
Indicators
Max power
Low speed/High speed
Fuel warmer
Auto idle

Door and cab locks, one key

Three outside rearview mirrors

Mechanical suspension seat with heater

Pilot-operated slidable joystick

Console box height adjust system

Four front working lights

Electric horn

Batteries (2 x 12V x 100 AH)

Battery master switch

Removable clean-out dust net for cooler

Automatic swing brake

Removable reservoir tank

Fuel pre-filter with fuel warmer

Boom holding system

Arm holding system

Track shoes (600mm, 24")

Track rail guard

Accumulator for lowering work equipment

Electric transducer

Lower frame under cover (Normal)

Viscous fan clutch

OPTIONAL EQUIPMENT

Fuel filler pump (50 L/min)

Beacon lamp

Safety lock valve for boom cylinder with overload warning device

Safety lock valve for arm cylinder

Single-acting piping kit (breaker, etc.)

Double-acting piping kit (clamshell, etc.)

Quick coupler

Travel alarm

Boom

5.68 m, 18' 8"

Arms

2.00 m, 6' 7"

2.40 m, 7' 10"

2.92 m, 9' 7"

Cabin lights

Cabin front window rain guard

Track shoes

700mm, 28"

800mm, 32"

900mm, 36"

Lower frame under cover (Additional)

Long crawler lower frame

Long crawler & Front dozer lower frame

Tool kit

Rearview camera

Pattern change valve (2 patterns)

Hi-mate (Remote Management System)

Cabin FOPS/FOG (ISO/DIS 10262)-Level II

FOPS (Falling Object Protective Structure)

FOG (Falling Object Guard)

* Standard and optional equipment may vary. Contact your Hyundai dealer for more information. The machine may vary according to International standards.

* The photos may include attachments and optional equipment that are not available in your area.

* Materials and specifications are subject to change without advance notice.

* All imperial measurements rounded off to the nearest pound or inch.

PLEASE CONTACT



6100 Atlantic Blvd, Norcross, GA 30071

TEL (678) 823-7777 FAX (678) 823-7778

Robex

235LCR-9A

With Tier 4 Interim Engine installed

MOVING YOU FURTHER

HYUNDAI HEAVY INDUSTRIES



*Photo may include optional equipment



HYUNDAI

CONSTRUCTION EQUIPMENT AMERICAS, INC.

Courtesy of Machine Market

PRIDE AT WORK

Hyundai Heavy Industries strives to build state-of-the-art earthmoving equipment to give every operator maximum performance, more precision, versatile machine preferences, and proven quality.

Take pride in your work with Hyundai!



Robex 235LCR-9A

Machine Walk-Around

Engine Technology

Proven, reliable, fuel efficient, low emission and low noise
Cummins Tier 4 interim & EU stage III B engine

Hydraulic System Improvements

New patented hydraulic control for improved controllability / Improved control valve design for added efficiency and smoother operation / New auto boom and swing priority system for optimum speed / New auto power boost feature for additional power when needed / Improved arm-in and boom-down flow regeneration system for added speed and efficiency

Pump Compartment

Industry-leading, powerful, reliable Kawasaki designed, variable volume in-line axial piston pumps
New compact solenoid block equipped with 4 solenoid valves, 1 EPPR valve, 1 check valve accumulator and pilot filter - controls 2 speed travel, power boost, boom priority, safety lock, arm regeneration

Enhanced Operator Cab

Improved Visibility

Enlarged cab with improved visibility / See-through upper skylight for visibility and ventilation
Larger right-side glass, now one piece, for better right visibility
Safety glass windows on all sides - less expensive than (polycarbonate) and won't scratch or fade
Closeable sunshade for operator convenience / Reduced front window seam for improved operator view

Improved Cab Construction

New steel tube construction for added operator safety, protection and durability
New window open/close mechanism designed with cable and spring lift assist and single latch release

Improved Suspension Seat / Console Assembly

Ergonomic joysticks with auxiliary control buttons for attachment use. Now with new sleek styling
Heated suspension (standard)

Advanced 7" Color Cluster with Touch Screen

New Color LCD Display with easy to read digital gauges for hydraulic oil temperature, water temperature, and fuel. Simplified design makes adjustment and diagnostics easier. Also, new enhanced features such as rear-view camera are integrated into monitor.

3 power modes : (P) Power, (S) Standard, (E) Economy, 2 work modes : Dig & Attachment, (U) User mode for operator preference

Enhanced self-diagnostic features with GPS download capability

One pump flow or two pump flow for optional attachment is now selectable through the cluster / New anti-theft system with password capability

Boom speed and arm regeneration are selectable through the monitor.

Auto power boost is now available - selectable (on/off) through the monitor.

Powerful air conditioning and heat with auto climate control

RMS (Remote Management System) works through GPS/satellite technology to ultimately provide better customer service and support.

Undercarriage

Sealed track chain (urethane seals) / Standard track rail guard / Comfortable bolt-on steps

Large upper roller cut-outs for debris clean-out / Tapered side frames for debris clean-out / Grease-type track tensioner

*Photo may include optional equipment.

PRECISION

Innovative hydraulic system technologies make the 9A series excavator fast, smooth and easy to control.



*Photo may include optional equipment.

Courtesy of Machine.Market

Computer Aided Power

The engine horsepower and hydraulic horsepower together in unison through the advanced CAPO(Computer Aided Power Optimization) system, flow for the job at hand. Operator can set their own preferences for boom or swing priority, power mode selection and optional work tools at the touch of a button.

The CAPO system also provides complete self diagnostic features and digital gauges for important information like hydraulic oil temperature, water temperatures and fuel level. This system interfaces with multiple sensors placed throughout the hydraulic system as well as the electronically controlled engine to provide the optimum level of engine power and hydraulic flow.

Power Mode

P (Power Max) mode maximizes machine speed and power for mass production. S (Standard) mode provides a reduced, fixed rpm for optimum performance and improved fuel economy. For maximum fuel savings and improved control, E (Economy) mode provides precise flow and engine power based on load demand. Three unique power modes provide the operator with custom power, speed and fuel economy.

Work Mode

The work mode allows the operator to select single flow attachments like a hydraulic breaker or bi-directional flow attachments like a crusher. Flow settings unique to each attachment can be programmed from within the cluster.

User Mode

Some jobs require more precise machine settings. Using the versatile U (User) mode, the operator can customize engine speed, pump output, idle speed and other machine settings for the job at hand.

Improved Hydraulic System



To achieve optimum precision, Hyundai redesigned the hydraulic system to provide the operator with super fine touch and improved controllability. Improved pump flow control reduces flow when controls are not being used to minimize fuel consumption.

Improved spool valves in the control valve are engineered to provide more precise flow to each function with less effort.

Improved hydraulic valves, precision-designed variable volume piston pumps, fine-touch pilot controls, and enhanced travel functions make any operator running a

9A series look like a smooth operator. Newly improved features include arm-in and boom-down flow regeneration, improved control valve technology and innovative auto boom and swing priority for optimal performance in any application.

Auto Boom-swing Priority

This smart function automatically and continuously looks the ideal hydraulic flow balance for the boom and swing motions of the machine. The advanced CAPO system monitors the hydraulic system and adjusts its settings to maximize performance and productivity.



PERFORMANCE

9A series is designed for maximum performance to keep the operator working productively.

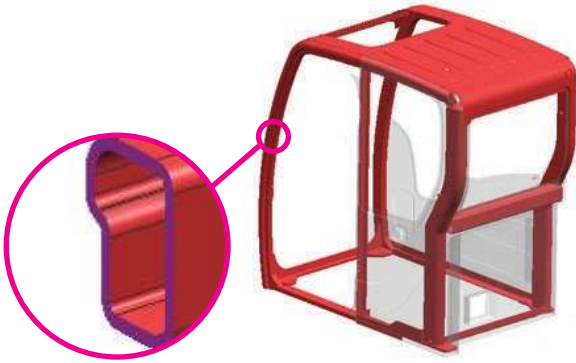

*Photo may include optional equipment.

Courtesy of Machine.Market

Track Rail Guard & Adjusters

Durable track rail guards keep track links in place. Track adjustment is made easy with standard grease cylinder track adjusters and shock absorbing springs.



Structure Strength

The 9A series cabin structure has been fitted with stronger but slimmer tubing for more safety and improved visibility. Low-stress, high strength steel is integrally welded to form a stronger, more durable upper and lower frame. Structural integrity was tested by way of FEM (Finite Elements Method) analysis and long-term durability tests. The ROPS(Roll Over Protective Structure) cab can be equipped to enhance operator safety.

Eco-friendly Cummins QSB 6.7 Engine

The CUMMINS QSB6.7 engine combines advanced electronic controls and a self-diagnostic system with reliable performance. The combination of a high pressure common rail system and an advanced in-cylinder combustion technology results in increased power, improved transient response and reduced fuel consumption. The QSB6.7 Cummins engine complies with current emissions standards including EPA Tier4 Interim and EU Stage III-B.

The Definition of Progress

The Quantum System B Series 6.7-liter engine combines full authority electronic controls with the reliable performance. The electronics with the QSB6.7 have been proven with our high-horse power products-working in the harshest, most demanding environments-search as dusty, non-stop mining operations while meeting emissions regulations worldwide.

The QSB6.7 features 24 valve designed with centered injectors and symmetrical piston bowl. The combination of improved air flow and evenly dispersed fuel results in increased power, improved transient reponse and reduced fuel consumption.



PREFERENCE

Operating a 9A series is unique to every operator. Operators can fully customize their work environment and operating preferences to fit their individual needs.



*Photo may include optional equipment.



Wide Cabin with Excellent Visibility

The newly designed cabin was conceived for more space, a wider field of view and operator comfort. Special attention was given to a clear, open and convenient interior with plenty of visibility on the machine surroundings and the job at hand. This well balanced combination of precision aspects put the operator in the perfect position to work safely and securely.

Operator Comfort

In the 9A series cabin you can easily adjust the seat, console and armrest settings to best suit your personal operating preferences. Seat and console position can be set together and independent from each other. Additional creature comforts include the fully automatic high-capacity airconditioning system and the radio / USB player.



Reduced Stress

Work is stressful enough. Your work environment should be stress free. Hyundai's 9A series provides improved cab amenities, additional space and a comfortable seat to minimize stress to the operator. A powerful climate control system provides the operator with optimum air temperature. An advanced audio system with USB player, AM/FM stereo and MP3 capabilities, plus remotely located controls is perfect for listening to music favorites. Operators can even talk on the phone with the hands-free cell phone feature. Also, the newly designed optional remote control offers mobile bluetooth-handsfree and radio cable-handsfree function.



Smart Key System (Option)

9A series excavators provide smart key system as an option. This allows the operator to start the engine by the push of a starter button without inserting a key in the ignition.



Operator - Friendly Cluster

The advanced new cluster with 7 inch wide color LCD with touch screen and toggle switch allows the operator to select his personal machine preferences. Power and work mode selection, self diagnostics, optional rear-view camera, maintenance check lists, start-up machine security, and video functions were integrated into the cluster to make the machine more versatile and the operator more productive.

The newly applied FM transmitter application transmits signal to USB & Radio player with the same frequency as cluster. The player outputs the audio through the internal speaker in the cab. The video & firmware updates are possible with USB host support and an adjustable cluster hinge bracket improves cluster visibility.

Monitor Tilt Range



Horizontal
Total : 15°



Vertical
Total : 30°



PROFITABILITY

9A series is designed to maximize profitability through improved efficiencies, enhanced service features and longer life components.



*Photo may include optional equipment.

Courtesy of Machine.Market

Fuel Efficiency

9A series excavators are engineered to be extremely fuel efficient. New innovations like two-stage auto decel system and the new economy mode help to conserve fuel and reduce the impact on the environment.



Hi-mate (Remote Management System)

Hi-mate, Hyundai's proprietary remote management system, provides operators and dealer service personnel access to vital service and diagnostic information on the machine from any computer with internet access. Users can pinpoint machine location using digital mapping and set machine work boundaries, reducing the need for multiple service calls. Hi-mate saves time and money for the owner and dealer by promoting preventative maintenance and reducing machine downtime.



Easy Access

Ground-line access to filters, lube fittings, fuses, machine computer components and wide open compartments makes service more convenient on the 9A series.



Long-Life Components

9A series excavators were designed with bushings designed for long-life lube intervals (250 hrs) & polymer shims (wear resistant, noise reducing), long-life hydraulic filters (1,000hrs), long-life hydraulic oil (5,000hrs), more efficient cooling systems and integrated preheating systems which extend service intervals, minimize operating costs and reduce machine down time.

Specifications

ENGINE

MODEL		CUMMINS QSB6.7 Engine	
Type		Water cooled, 4 cycle Diesel, 6-cylinders in line, direct injection, turbocharged charger and air cooled	
Rated flywheel horse power	SAE	J1995 (gross)	167HP (124kW)/ 1,950 rpm
		J1349 (net)	157HP (117kW)/ 1,950 rpm
	DIN	6271/1 (gross)	169PS (124kW)/ 1,950 rpm
		6271/1 (net)	159PS (117kW)/ 1,950 rpm
Max. torque		74.7kgf-m (540lb-ft)/1,500rpm	
Bore X stroke		107mm X 124mm (4.2" X 4.9")	
Piston displacement		6,700cc (409 in ³)	
Batteries		2 X 12V X 100AH	
Starting motor		24V, 4.8kW	
Alternator		24V, 95Amp	

HYDRAULIC SYSTEM

MAIN PUMP	
Type	Variable displacement tandem axis piston pumps
Rated flow	2 X 228.2 L/min (60.3 US gpm/50.2 UK gpm)
Sub-pump for pilot circuit	Gear pump
Cross-sensing and fuel saving pump system.	

HYDRAULIC MOTORS	
Travel	Two speed axial pistons motor with brake valve and parking brake
Swing	Axial piston motor with automatic brake

RELIEF VALVE SETTING	
Implement circuits	350 kgf/cm ² (4,980 psi)
Travel	350 kgf/cm ² (4,980 psi)
Power boost (boom, arm, bucket)	380 kgf/cm ² (5,410 psi)
Swing circuit	285 kgf/cm ² (4,050 psi)
Pilot circuit	40 kgf/cm ² (570 psi)
Service valve	Installed

HYDRAULIC CYLINDERS	
No. of cylinder bore X stroke	Boom: 2-120 X 1,290 mm (4.7" X 50.8")
	Arm: 1-140 X 1,510 mm (5.5" X 59.4")
	Bucket: 1-120 X 1,055 mm (4.7" X 41.5")

DRIVES & BRAKES

Drive method	Fully hydrostatic type
Drive motor	Axial piston motor, in-shoe design
Reduction system	Planetary reduction gear
Max. drawbar pull	21,400 kgf (47,180 lbf)
Max. travel speed(high) / (low)	5.8 km/hr (3.6mph) / 3.4 km/hr (2.1mph)
Gradeability	30° (58 %)
Parking brake	Multi wet disc

CONTROL

Pilot pressure operated joysticks and pedals with detachable lever provide almost effortless and fatigueless operation.

Pilot control	Two joysticks with one safety lever (LH): Swing and arm, (RH): Boom and bucket(ISO)
Traveling and steering	Two levers with pedals
Engine throttle	Electric, Dial type

SWING SYSTEM

Swing motor	Fixed displacement axial piston motor
Swing reduction	Planetary gear reduction
Swing bearing lubrication	Grease-bathed
Swing brake	Multi wet disc
Swing speed	10.7 rpm

COOLANT & LUBRICANT CAPACITY

Refilling	liter	US gal	UK gal
Fuel tank	320	84.5	70.4
Engine coolant	38	10	8.4
Engine oil	23.7	6.3	5.2
Swing device-gear oil	6.2	1.6	1.4
Final drive(each)-gear oil	6	1.6	1.3
Hydraulic system(including tank)	275	72.6	60.5
Hydraulic tank	160	42.3	35.2

UNDERCARRIAGE

The X-leg type center frame is integrally welded with reinforced box-section track frames. The undercarriage includes lubricated rollers, idlers, track adjusters with shock absorbing springs and sprockets, and a track chain with double or triple grouser shoes.

Center frame	X - leg type
Track frame	Pentagonal box type
No. of shoes on each side	49 EA
No. of carrier roller on each side	2 EA
No. of track roller on each side	9 EA
No. of rail guard on each side	2 EA

OPERATING WEIGHT (APPROXIMATE)

Operating weight, including 5,680mm (18' 8") boom, 2,920mm (9' 7") arm, SAE heaped 0.80m³ (1.05 yd³) bucket, lubricant, coolant, full fuel tank, full hydraulic tank, and all standard equipments.

MAJOR COMPONENT WEIGHT	
Upperstructure	5,600 kg (12,350 lb)
Boom(with arm cylinder)	1,950 kg (4,300 lb)
Arm(with bucket cylinder)	1,095 kg (2,410 lb)

OPERATING WEIGHT			
Shoes		Operating weight	Ground pressure
Type	Width mm(in)	kg(lb)	kgf/cm ² (psi)
Triple grouser	600 (24")	23,800 (52,470)	0.51 (7.25)
	700 (28")	24,060 (53,040)	0.44 (6.26)
	800 (32")	24,320 (53,620)	0.39 (5.55)
	900 (36")	24,580 (54,190)	0.35 (4.98)

BUCKETS

All buckets are welded with high-strength steel.



SAE
heaped
m³ (yd³)



0.80 (1.05)
0.87 (1.14)
0.92 (1.20)



1.10 (1.44)
1.20 (1.57)

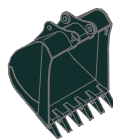

1.34 (1.75)



* 0.74 (0.97)
* 0.90 (1.18)
* 1.05 (1.37)



● 0.87 (1.14)

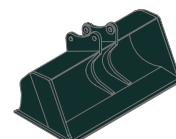

▣ 0.75 (0.98)

Capacity m ³ (yd ³)		Width mm (in)		Weight kg (lb)	Recommendation mm (ft-in)		
SAE heaped	CECE heaped	Without side cutters	With side cutters		5,680 (18' 8") Boom		
				2,000 (6' 7") Arm		2,400 (7' 10") Arm	2,920 (9' 7") Arm
0.51 (0.67)	0.45 (0.59)	700 (27.6)	820 (32.3)	570 (1,260)	●	●	●
0.80 (1.05)	0.70 (0.92)	1,000 (39.4)	1,120 (44.1)	700 (1,540)	●	●	●
0.87 (1.14)	0.75 (0.98)	1,090 (42.9)	1,210 (47.6)	740 (1,630)	●	●	■
0.92 (1.20)	0.80 (1.05)	1,150 (45.3)	1,270 (50.0)	770 (1,700)	●	●	■
1.10 (1.44)	0.96 (1.26)	1,320 (52.0)	1,440 (56.7)	830 (1,830)	●	■	▲
1.20 (1.57)	1.00 (1.31)	1,400 (55.1)	1,520 (59.8)	850 (1,870)	■	▲	-
1.34 (1.75)	1.15 (1.50)	1,550 (61.0)	1,670 (65.7)	920 (2,030)	▲	▲	-
* 0.74 (0.97)	0.65 (0.85)	985 (38.8)	-	770 (1,700)	●	●	●
* 0.90 (1.18)	0.80 (1.05)	1,070 (42.1)	-	810 (1,790)	●	●	■
* 1.05 (1.37)	0.92 (1.20)	1,290 (50.8)	-	890 (1,960)	●	■	▲
● 0.87 (1.14)	0.75 (0.98)	1,140 (44.9)	-	900 (1,980)	●	●	■
▣ 0.75 (0.98)	0.65 (0.85)	1,790 (70.5)	-	880 (1,940)	●	●	■

* Heavy duty bucket

▣ Slope finishing bucket

● Rock-Heavy duty bucket

●: Applicable for materials with density of 2,000 kg/m³ (3,370 lb/ yd³) or less

■: Applicable for materials with density of 1,600 kg/m³ (2,700 lb/ yd³) or less

▲: Applicable for materials with density of 1,100 kg/m³ (1,850 lb/ yd³) or less

ATTACHMENT

Booms and arms are welded with a low-stress, full-box section design. 5.68m Boom and 2.0m, 2.4m, 2.92m Arms are available.

DIGGING FORCE

Boom	Length	mm (ft-in)	5,680 (18' 8")			Remarks
	Weight	kg (lb)	1,950 (4,300)			
Arm	Length	mm (ft-in)	2,000 (6' 7")	2,400 (7' 10")	2,920 (9' 7")	Remarks
	Weight	kg (lb)	975 (2,150)	1,045 (2,300)	1,095 (2,410)	
Bucket digging force	SAE	kN	133.4 [144.8]	133.4 [144.8]	133.4 [144.8]	[]: Power Boost
		kgf	13600 [14770]	13600 [14770]	13600 [14770]	
		lbf	29980 [32550]	29980 [32550]	29980 [32550]	
	ISO	kN	152.0 [165.0]	152.0 [165.0]	152.0 [165.0]	
		kgf	15500 [16830]	15500 [16830]	15500 [16830]	
		lbf	34170 [37100]	34170 [37100]	34170 [37100]	
Arm crowd force	SAE	kN	144.2 [156.5]	119.6 [129.9]	102.0 [110.7]	
		kgf	14700 [15960]	12200 [13250]	10400 [11290]	
		lbf	32410 [35190]	26900 [29210]	22930 [24900]	
	ISO	kN	151.0 [164.0]	125.5 [136.3]	106.9 [116.1]	
		kgf	15400 [16720]	12800 [13900]	10900 [11830]	
		lbf	33950 [36860]	28220 [30640]	24030 [26090]	

Note: Boom weight includes arm cylinder, piping, and pin

Arm weight includes bucket cylinder, linkage, and pin

Dimensions & Working Range

R235LCR-9A DIMENSIONS

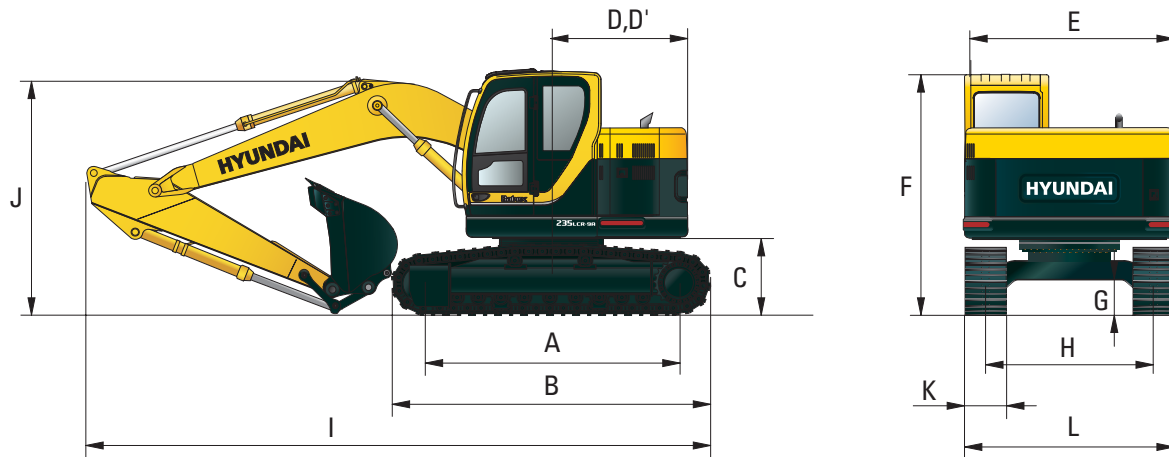

mm (ft-in)

A Tumbler distance	3,650 (11' 12")	Boom length	5,680 (18' 8")			
B Overall length of crawler	4,440 (14' 7")	Arm length	2,000 (6' 7")	2,400 (7' 10")	2,920 (9' 7")	
C Ground clearance of counterweight	1,060 (3' 6")	I Overall length	9,040 (29' 8")	8,950 (29' 4")	8,910 (29' 3")	
D Tail swing radius	1,780 (6' 04")	J Overall height of boom	3,200 (10' 6")	3,100 (10' 2")	3,020 (9' 11")	
D' Rear-end length	1,780 (6' 04")	K Track shoe width	600 (24")	700 (28")	800 (32")	900 (36")
E Overall width of upperstructure	2,980 (9' 9")	L Overall width	2,990 (9' 10")	3,090 (10' 2")	3,190 (10' 6")	3,290 (10' 10")
F Overall height of cab	2,950 (9' 8")					
G Min. ground clearance	480 (1' 7")					
H Track gauge	2,390 (7' 10")					

R235LCR-9A WORKING RANGE

mm (ft-in)

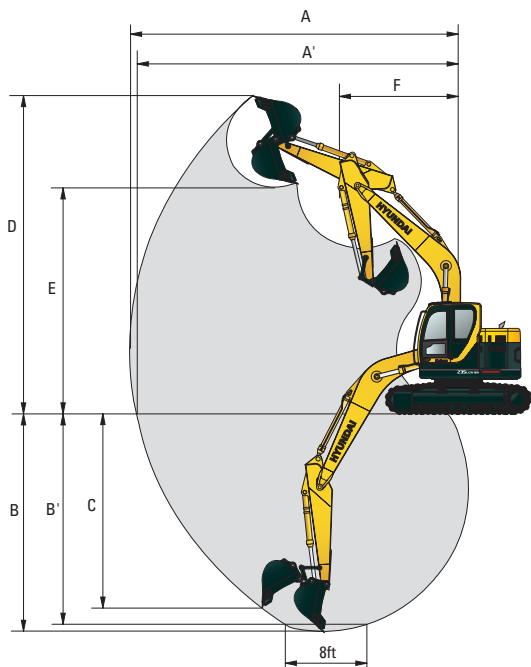

Boom length	5,680 (18' 8")		
Arm length	2,000 (6' 7")	2,400 (7' 10")	2,920 (9' 7")
A Max. digging reach	9,040 (29' 8")	9,430 (30' 11")	9,910 (32' 6")
A' Max. digging reach on ground	8,860 (29' 1")	9,260 (30' 5")	9,750 (31' 12")
B Max. digging depth	5,780 (18' 12")	6,180 (20' 3")	6,700 (21' 12")
B' Max. digging depth (8' level)	5,550 (18' 3")	5,980 (19' 7")	6,530 (21' 5")
C Max. vertical wall digging depth	5,140 (16' 10")	5,710 (18' 9")	6,270 (20' 7")
D Max. digging height	10,090 (33' 1")	10,420 (34' 2")	10,830 (35' 6")
E Max. dumping height	7,190 (23' 7")	7,510 (24' 8")	7,890 (25' 11")
F Min. swing radius	2,860 (9' 5")	2,550 (8' 4")	2,350 (7' 9")

Dimensions & Working Range

R235LCR-9A (DOZER TYPE) DIMENSIONS

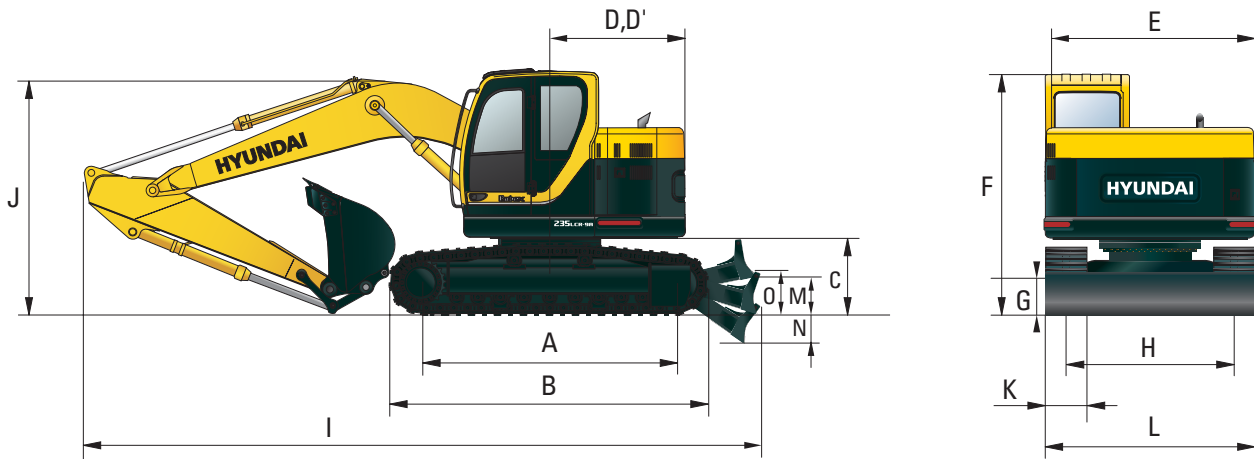

mm (ft-in)

A Tumbler distance	3,650 (11' 12")	Boom length	5,680 (18' 8")			
B Overall length of crawler	4,440 (14' 7")	Arm length	2,000 (6' 7")	2,400 (7' 10")	2,920 (9' 7")	
C Ground clearance of counterweight	1,060 (3' 6")	I Overall length	10,020 (32' 10")	9,930 (32' 7")	9,890 (32' 5")	
D Tail swing radius	1,780 (6' 04")	J Overall height of boom	3,200 (10' 6")	3,100 (10' 2")	3,020 (9' 11")	
D' Rear-end length	1,780 (6' 04")	K Track shoe width	600 (24")	700 (28")	800 (32")	900 (36")
E Overall width of upperstructure	2,980 (9' 9")	L Overall width	2990 (9' 10")	3,090 (10' 2")	3,190 (10' 6")	3,290 (10' 10")
F Overall height of cab	2,950 (9' 8")					
G Min. ground clearance	480 (1' 7")					
H Track gauge	2,390 (7' 10")					
M Ground clearance of blade up	575 (1' 11")					
N Depth of blade down	390 (1' 3")					
O Height of blade	710 (2' 4")					

R235LCR-9A (DOZER TYPE) WORKING RANGE

mm (ft-in)

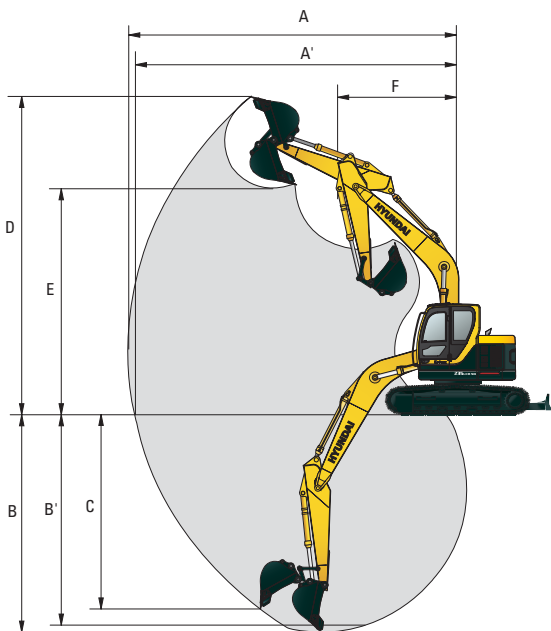











Boom length	5,680 (18' 8")		
Arm length	2,000 (6' 7")	2,400 (7' 10")	2,920 (9' 7")
A Max. digging reach	9,040 (29' 8")	9,430 (30' 11")	9,910 (32' 6")
A' Max. digging reach on ground	8,860 (29' 1")	9,260 (30' 5")	9,750 (31' 12")
B Max. digging depth	5,780 (18' 3")	6,180 (20' 3")	6,700 (21' 12")
B' Max. digging depth (8' level)	5,555 (18' 3")	5,980 (19' 7")	6,530 (21' 5")
C Max. vertical wall digging depth	5,140 (16' 10")	5,710 (18' 9")	6,270 (20' 7")
D Max. digging height	10,090 (33' 1")	10,420 (34' 2")	10,830 (35' 6")
E Max. dumping height	7,190 (23' 7")	7,510 (24' 8")	7,890 (25' 11")
F Min. swing radius	2,860 (9' 5")	2,550 (8' 4")	2,350 (7' 9")

Lifting Capacity











R235LCR-9A

 Rating over-front  Rating over-side or 360 degree











Boom : 5.68 m (18' 8") / Arm : 2.0 m (6' 7") / Bucket : 0.80 m³ (1.05yd) SAE heaped / Shoe : 600mm(24") triple grouser

Load point height m (ft)		Load radius								At max. reach		
		3.0 m (10 ft)		4.5 m (15 ft)		6.0 m (20 ft)		7.5 m (25 ft)		Capacity		Reach m (ft)
												
10.5 m (35 ft)	kg									*4210	*4210	4.63
	lb									*9280	*9280	(15.2)
9.0 m (30 ft)	kg									*4630	*4630	4.48
	lb									*10210	*10210	(14.7)
7.5 m (25 ft)	kg			*4820	*4820					*4150	*4150	6.56
	lb			*10630	*10630					*9150	*9150	(21.5)
6.0 m (20 ft)	kg			*4980	*4980	*4590	*4590			*4050	3060	7.70
	lb			*10980	*10980	*10120	*10120			*8930	6750	(25.3)
4.5 m (15 ft)	kg	*8350	*8350	*5930	*5930	*4910	4570			*4050	2560	8.36
	lb	*18410	*18410	*13070	*13070	*10820	10080			*8930	5640	(27.4)
3.0m (10 ft)	kg			*7310	6760	*5490	4310	*4620	2960	*4080	2320	8.67
	lb			*16120	14900	*12100	9500	*10190	6530	*8990	5110	(28.4)
1.5 m (5 ft)	kg			*8410	6250	*6040	4070	*4820	2860	*4130	2270	8.66
	lb			*18540	13780	*13320	8970	*10630	6310	*9110	5000	(28.4)
Ground Line	kg			*8720	6020	*6300	3910			*4150	2390	8.36
	lb			*19220	13270	*13890	8620			*9150	5270	(27.4)
-1.5 m (-5 ft)	kg	*11480	*11480	*8320	5980	*6110	3860			*4070	2760	7.69
	lb	*25310	*25310	*18340	13180	*13470	8510			*8970	6080	(25.2)
-3.0 m (-10 ft)	kg	*9710	*9710	*7190	6090	*5140	3950			*3660	3660	6.55
	lb	*21410	*21410	*15850	13430	*11330	8710			*8070	8070	(21.5)

Boom : 5.68 m (18' 8") / Arm : 2.40 m (7' 10") / Bucket : 0.80 m³ (1.05 yd) SAE heaped / Shoe : 600mm(24") triple grouser

Load point height m (ft)		Load radius								At max. reach				
		1.5 m (5 ft)		3.0 m (10 ft)		4.5 m (15 ft)		6.0 m (20 ft)		7.5 m (25 ft)		Capacity		Reach m (ft)
														
9.0 m (30 ft)	kg											*4110	*4110	5.25
	lb											*9060	*9060	(17.2)
7.5 m (25 ft)	kg					*4280	*4280					*3820	3670	7.07
	lb					*9440	*9440					*8420	8090	(23.2)
6.0 m (20 ft)	kg					*4500	*4500	*4220	*4220			*3760	2780	8.12
	lb					*9920	*9920	*9300	*9300			*8290	6130	(26.6)
4.5 m (15 ft)	kg			*7270	*7270	*5450	*5450	*4600	*4600	*3950	3080	*3770	2350	8.74
	lb			*16030	*16030	*12020	*12020	*10140	*10140	*8710	6790	*8310	5180	(28.7)
3.0m (10 ft)	kg			*11380	*11380	*6850	*6850	*5230	4350	*4420	2980	*3820	2150	9.04
	lb			*25090	*25090	*15100	*15100	*11530	9590	*9740	6570	*8420	4740	(29.7)
1.5 m (5 ft)	kg					*8100	6310	*5840	4080	*4690	2850	3850	2090	9.03
	lb					*17860	13910	*12870	8990	*10340	6280	8490	4610	(29.6)
Ground Line	kg			*9120	*9120	*8640	6000	*6210	3890	*4820	2750	*3930	2190	8.74
	lb			*20110	*20110	*19050	13230	*13690	8580	*10630	6060	*8660	4830	(28.7)
-1.5 m (-5 ft)	kg	*9720	*9720	*12220	11860	*8450	5920	*6160	3810			*3900	2490	8.12
	lb	*21430	*21430	*26940	26150	*18630	13050	*13580	8400			*8600	5490	(26.6)
-3.0 m (-10 ft)	kg	*14180	*14180	*10550	*10550	*7550	5990	*5480	3850			*3650	3190	7.06
	lb	*31260	*31260	*23260	*23260	*16640	13210	*12080	8490			*8050	7030	(23.2)
-4.5 m (-15 ft)	kg			*7670	*7670	*5530	*5530							
	lb			*16910	*16910	*12190	*12190							

Boom : 5.68 m (18' 8") / Arm : 2.92 m (9' 7") / Bucket : 0.80 m³ (1.05 yd) SAE heaped / Shoe : 600mm(24") triple grouser

Load point height m (ft)		Load radius								At max. reach				
		1.5 m (5 ft)		3.0 m (10 ft)		4.5 m (15 ft)		6.0 m (20 ft)		7.5 m (25 ft)		Capacity		Reach m (ft)
														
9.0 m (30 ft)	kg					*2970	*2970					*3630	*3630	6.12
	lb					*6550	*6550					*8000	*8000	(20.1)
7.5 m (25 ft)	kg							*3310	*3310			*3460	3180	7.70
	lb							*7300	*7300			*7630	7010	(25.3)
6.0 m (20 ft)	kg							*3780	*3780			*3430	2480	8.66
	lb							*8330	*8330			*7560	5470	(28.4)
4.5 m (15 ft)	kg					*4810	*4810	*4190	*4190	*3860	3140	*3460	2120	9.24
	lb					*10600	*10600	*9240	*9240	*8510	6920	*7630	4670	(30.3)
3.0m (10 ft)	kg			*9730	*9730	*6240	*6240	*4860	4410	*4150	3000	*3520	1940	9.52
	lb			*21450	*21450	*13760	*13760	*10710	9720	*9150	6610	*7760	4280	(31.2)
1.5 m (5 ft)	kg			*9500	*9500	*7650	6410	*5560	4110	*4490	2850	3520	1890	9.52
	lb			*20940	*20940	*16870	14130	*12260	9060	*9900	6280	7760	4170	(31.2)
Ground Line	kg			*9890	*9890	*8460	6010	*6050	3880	*4720	2730	*3650	1960	9.24
	lb			*21800	*21800	*18650	13250	*13340	8550	*10410	6020	*8050	4320	(30.3)
-1.5 m (-5 ft)	kg	*8800	*8800	*12860	11680	*8530	5850	*6160	3760	*4690	2660	*3670	2190	8.66
	lb	*19400	*19400	*28350	25750	*18810	12900	*13580	8290	*10340	5860	*8090	4830	(28.4)
-3.0 m (-10 ft)	kg	*12230	*12230	*11440	*11440	*7900	5870	*5740	3750			*3560	2720	7.69
	lb	*26960	*26960	*25220	*25220	*17420	12940	*12650	8270			*7850	6000	(25.2)
-4.5 m (-15 ft)	kg			*8990	*8990	*6360	6050					*2980	*2980	6.11
	lb			*19820	*19820	*14020	13340					*6570	*6570	(20.0)











- Lifting capacity is based on SAE J1097, ISO 10567.
- Lifting capacity of the Robex Series does not exceed 75% of the tipping load with the machine on firm, level ground or 87% of full hydraulic capacity.
- The load point is a hook located on the back of the bucket.
- (*) indicates the load limited by hydraulic capacity.

Lifting Capacity











R235LCR-9A (DOZER TYPE)

 Rating over-front  Rating over-side or 360 degree

Boom : 5.68 m (18' 8") / Arm : 2.0 m (6' 7") / Bucket : 0.80 m³ (1.05yd³) SAE heaped / Shoe : 600mm(24") triple grouser, Dozer blade Down

Load point height m (ft)		Load radius								At max. reach		Reach m (ft)
		3.0 m (10 ft)		4.5 m (15 ft)		6.0 m (20 ft)		7.5 m (25 ft)		Capacity		
												
10.5 m (35 ft)	kg lb									*4210 *9280	*4210 *9280	4.63 (15.2)
9.0 m (30 ft)	kg lb									*4630 *10210	*4630 *10210	4.48 (14.7)
7.5 m (25 ft)	kg lb			*4820 *10630	*4820 *10630					*4150 *9150	*4150 *9150	6.56 (21.5)
6.0 m (20 ft)	kg lb			*4980 *10980	*4980 *10980	*4590 *10120	*4590 *10120			*4050 *8930	3460 7630	7.70 (25.3)
4.5 m (15 ft)	kg lb	*8350 *18410	*8350 *18410	*5930 *13070	*5930 *13070	*4910 *10820	*4910 *10820			*4050 *8930	2920 6440	8.36 (27.4)
3.0 m (10 ft)	kg lb			*7310 *16120	*7310 *16120	*5490 *12100	4890 10780	*4620 *10190	3380 7450	*4080 *8990	2670 5890	8.67 (28.4)
1.5 m (5 ft)	kg lb			*8410 *18540	7130 15720	*6040 *13320	4640 10230	*4820 *10630	3280 7230	*4130 *9110	2620 5780	8.66 (28.4)
Ground Line	kg lb			*8720 *19220	6900 15210	*6300 *13890	4480 9880			*4150 *9150	2760 6080	8.36 (27.4)
-1.5 m (-5 ft)	kg lb	*11480 *25310	*11480 *25310	*8320 *18340	6860 15120	*6110 *13470	4430 9770			*4070 *8970	3160 6970	7.69 (25.2)
-3.0 m (-10 ft)	kg lb	*9710 *21410	*9710 *21410	*7190 *15850	6980 15390	*5140 *11330	4520 9960			*3660 *8070	*3660 *8070	6.55 (21.5)

Boom : 5.68 m (18' 8") / Arm : 2.0 m (6' 7") / Bucket : 0.80 m³ (1.05yd³) SAE heaped / Shoe : 600mm(24") triple grouser, Dozer blade Up

Load point height m (ft)		Load radius								At max. reach		Reach m (ft)
		3.0 m (10 ft)		4.5 m (15 ft)		6.0 m (20 ft)		7.5 m (25 ft)		Capacity		
												
10.5 m (35 ft)	kg lb									*4210 *9280	*4210 *9280	4.63 (15.2)
9.0 m (30 ft)	kg lb									*4630 *10210	*4630 *10210	4.48 (14.7)
7.5 m (25 ft)	kg lb			*4820 *10630	*4820 *10630					*4150 *9150	*4150 *9150	6.56 (21.5)
6.0 m (20 ft)	kg lb			*4980 *10980	*4980 *10980	*4590 *10120	*4590 *10120			*4050 *8930	3250 7170	7.70 (25.3)
4.5 m (15 ft)	kg lb	*8350 *18410	*8350 *18410	*5930 *13070	*5930 *13070	*4910 *10820	4830 10650			*4050 *8930	2730 6020	8.36 (27.4)
3.0 m (10 ft)	kg lb			*7310 *16120	7140 15740	*5490 *12100	4570 10080	*4620 *10190	3160 6970	*4080 *8990	2490 5490	8.67 (28.4)
1.5 m (5 ft)	kg lb			*8410 *18540	6630 14620	*6040 *13320	4330 9550	*4820 *10630	3050 6720	4060 8950	2440 5380	8.66 (28.4)
Ground Line	kg lb			*8720 *19220	6400 14110	*6300 *13890	4170 9190			*4150 *9150	2570 5670	8.36 (27.4)
-1.5 m (-5 ft)	kg lb	*11480 *25310	*11480 *25310	*8320 *18340	6360 14020	*6110 *13470	4120 9080			*4070 *8970	2950 6500	7.69 (25.2)
-3.0 m (-10 ft)	kg lb	*9710 *21410	*9710 *21410	*7190 *15850	6470 14260	*5140 *11330	4210 9280			*3660 *8070	*3660 *8070	6.55 (21.5)













- Lifting capacity is based on SAE J1097, ISO 10567.
- Lifting capacity of the Robex Series does not exceed 75% of the tipping load with the machine on firm, level ground or 87% of full hydraulic capacity.
- The load point is a hook located on the back of the bucket.
- (*) indicates the load limited by hydraulic capacity.

Lifting Capacity













R235LCR-9A (DOZER TYPE)

 Rating over-front  Rating over-side or 360 degree

Boom : 5.68 m (18' 8") / Arm : 2.40 m (7' 10") / Bucket : 0.80 m³ (1.05 yd) SAE heaped / Shoe : 600mm(24") triple grouser, Dozer blade Down

Load point height m (ft)		Load radius										At max. reach		
		1.5 m (5 ft)		3.0 m (10 ft)		4.5 m (15 ft)		6.0 m (20 ft)		7.5 m (25 ft)		Capacity		Reach m (ft)
														
9.0 m (30 ft)	kg											*4110	*4110	5.25 (17.2)
7.5 m (25 ft)	kg					*4280	*4280					*9060	*9060	7.07 (23.2)
6.0 m (20 ft)	kg					*9440	*9440					*3820	*3820	7.06 (23.2)
6.0 m (20 ft)	lb					*4500	*4500	*4220	*4220			*8420	*8420	8.12 (26.6)
4.5 m (15 ft)	kg			*7270	*7270	*5450	*5450	*4600	*4600	*3950	3510	*3770	*3770	8.74 (28.7)
4.5 m (15 ft)	lb			*16030	*16030	*12020	*12020	*10140	*10140	*8710	7740	*8310	*8310	9.04 (29.7)
3.0 m (10 ft)	kg			*11380	*11380	*6850	*6850	*5230	4920	*4420	3400	*3820	*3820	9.03 (29.6)
3.0 m (10 ft)	lb			*25090	*25090	*15100	*15100	*11530	10850	*9740	7500	*8420	*8420	8.74 (28.7)
1.5 m (5 ft)	kg					*8100	7190	*5840	4650	*4690	3270	*3880	*3880	8.12 (26.6)
1.5 m (5 ft)	lb					*17860	15850	*12870	10250	*10340	7210	*8660	*8660	9.04 (29.7)
Ground Line	kg			*9120	*9120	*8640	6880	*6210	4460	*4820	3170	*3930	*3930	8.74 (28.7)
Ground Line	lb			*20110	*20110	*19050	15170	*13690	9830	*10630	6990	*8660	*8660	8.12 (26.6)
-1.5 m (-5 ft)	kg	*9720	*9720	*12220	*12220	*8450	6790	*6160	4370			*3900	*3900	7.06 (23.2)
-1.5 m (-5 ft)	lb	*21430	*21430	*26940	*26940	*18630	14970	*13580	9630			*8600	*8600	7.06 (23.2)
-3.0 m (-10 ft)	kg	*14180	*14180	*10550	*10550	*7550	6870	*5480	4420			*3650	*3650	7.06 (23.2)
-3.0 m (-10 ft)	lb	*31260	*31260	*23260	*23260	*16640	15150	*12080	9740			*8050	*8050	7.06 (23.2)
-4.5 m (-15 ft)	kg			*7670	*7670	*5530	*5530							
-4.5 m (-15 ft)	lb			*16910	*16910	*12190	*12190							

Boom : 5.68 m (18' 8") / Arm : 2.40 m (7' 10") / Bucket : 0.80 m³ (1.05 yd) SAE heaped / Shoe : 600mm(24") triple grouser, Dozer blade Up

Load point height m (ft)		Load radius										At max. reach		
		1.5 m (5 ft)		3.0 m (10 ft)		4.5 m (15 ft)		6.0 m (20 ft)		7.5 m (25 ft)		Capacity		Reach m (ft)
														
9.0 m (30 ft)	kg											*4110	*4110	5.25 (17.2)
7.5 m (25 ft)	kg					*4280	*4280					*9060	*9060	7.07 (23.2)
6.0 m (20 ft)	kg					*9440	*9440					*3820	*3820	7.06 (23.2)
6.0 m (20 ft)	lb					*4500	*4500	*4220	*4220			*8420	*8420	8.12 (26.6)
4.5 m (15 ft)	kg			*7270	*7270	*5450	*5450	*4600	*4600	*3950	3280	*3770	*3770	8.74 (28.7)
4.5 m (15 ft)	lb			*16030	*16030	*12020	*12020	*10140	*10140	*8710	7230	*8310	*8310	9.04 (29.7)
3.0 m (10 ft)	kg			*11380	*11380	*6850	*6850	*5230	4610	*4420	3170	*3820	*3820	9.03 (29.6)
3.0 m (10 ft)	lb			*25090	*25090	*15100	*15100	*11530	10160	*9740	6990	*8420	*8420	8.74 (28.7)
1.5 m (5 ft)	kg					*8100	6690	*5840	4340	*4690	3050	*3780	*3780	8.12 (26.6)
1.5 m (5 ft)	lb					*17860	14750	*12870	9570	*10340	6720	*8330	*8330	9.03 (29.6)
Ground Line	kg			*9120	*9120	*8640	6380	*6210	4150	*4820	2950	*3930	*3930	8.74 (28.7)
Ground Line	lb			*20110	*20110	*19050	14070	*13690	9150	*10630	6500	*8660	*8660	8.12 (26.6)
-1.5 m (-5 ft)	kg	*9720	*9720	*12220	*12220	*8450	6300	*6160	4070			*3900	*3900	7.06 (23.2)
-1.5 m (-5 ft)	lb	*21430	*21430	*26940	*26940	*18630	13890	*13580	8970			*8600	*8600	7.06 (23.2)
-3.0 m (-10 ft)	kg	*14180	*14180	*10550	*10550	*7550	6370	*5480	4110			*3650	*3650	7.06 (23.2)
-3.0 m (-10 ft)	lb	*31260	*31260	*23260	*23260	*16640	14040	*12080	9060			*8050	*8050	7.06 (23.2)
-4.5 m (-15 ft)	kg			*7670	*7670	*5530	*5530							
-4.5 m (-15 ft)	lb			*16910	*16910	*12190	*12190							













- Lifting capacity is based on SAE J1097, ISO 10567.
- Lifting capacity of the Robex Series does not exceed 75% of the tipping load with the machine on firm, level ground or 87% of full hydraulic capacity.
- The load point is a hook located on the back of the bucket.
- (*) indicates the load limited by hydraulic capacity.

Lifting Capacity













R235LCR-9A (DOZER TYPE)

 Rating over-front  Rating over-side or 360 degree

Boom : 5.68 m (18' 8") / Arm : 2.92 m (9' 7") / Bucket : 0.80 m³ (1.05 yd³) SAE heaped / Shoe : 600mm(24") triple grouser, Dozer blade Down

Load point height m (ft)		Load radius										At max. reach		
		1.5 m (5 ft)		3.0 m (10 ft)		4.5 m (15 ft)		6.0 m (20 ft)		7.5 m (25 ft)		Capacity		Reach m (ft)
														
9.0 m (30 ft)	kg					*2970	*2970					*3630	*3630	6.12
	lb					*6550	*6550					*8000	*8000	(20.1)
7.5 m (25 ft)	kg							*3310	*3310			*3460	*3460	7.70
	lb							*7300	*7300			*7630	*7630	(25.3)
6.0 m (20 ft)	kg							*3780	*3780			*3430	*2830	8.66
	lb							*8330	*8330			*7560	6240	(28.4)
4.5 m (15 ft)	kg					*4810	*4810	*4190	*4190	*3860	3560	*3460	2440	9.24
	lb					*10600	*10600	*9240	*9240	*8510	7850	*7630	5380	(30.3)
3.0 m (10 ft)	kg		*9730	*9730	*6240	*6240	*4860	*4860	*4150	3420	*3520	2250	9.52	
	lb		*21450	*21450	*13760	*13760	*10710	*10710	*9150	7540	*7760	4960	(31.2)	
1.5 m (5 ft)	kg		*9500	*9500	*7650	7300	*5560	4680	*4490	3270	*3590	2200	9.52	
	lb		*20940	*20940	*16870	16090	*12260	10320	*9900	7210	*7910	4850	(31.2)	
Ground Line	kg		*9890	*9890	*8460	6890	*6050	4450	*4720	3140	*3650	2280	9.24	
	lb		*21800	*21800	*18650	15190	*13340	9810	*10410	6920	*8050	5030	(30.3)	
-1.5 m (-5 ft)	kg	*8800	*8800	*12860	*12860	*8530	6730	*6160	4320	*4690	3080	*3670	2540	8.66
	lb	*19400	*19400	*28350	*28350	*18810	14840	*13580	9520	*10340	6790	*8090	5600	(28.4)
-3.0 m (-10 ft)	kg	*12230	*12230	*11440	*11440	*7900	6750	*5740	4320			*3560	3120	7.69
	lb	*26960	*26960	*25220	*25220	*17420	14880	*12650	9520			*7850	6880	(25.2)
-4.5 m (-15 ft)	kg			*8990	*8990	*6360	*6360					*2980	*2980	6.11
	lb			*19820	*19820	*14020	*14020					*6570	*6570	(20.0)

Boom : 5.68 m (18' 8") / Arm : 2.92 m (9' 7") / Bucket : 0.80 m³ (1.05 yd³) SAE heaped / Shoe : 600mm(24") triple grouser, Dozer blade Up

Load point height m (ft)		Load radius										At max. reach		
		1.5 m (5 ft)		3.0 m (10 ft)		4.5 m (15 ft)		6.0 m (20 ft)		7.5 m (25 ft)		Capacity		Reach m (ft)
														
9.0 m (30 ft)	kg					*2970	*2970					*3630	*3630	6.12
	lb					*6550	*6550					*8000	*8000	(20.1)
7.5 m (25 ft)	kg							*3310	*3310			*3460	3370	7.70
	lb							*7300	*7300			*7630	7430	(25.3)
6.0 m (20 ft)	kg							*3780	*3780			*3430	2650	8.66
	lb							*8330	*8330			*7560	5840	(28.4)
4.5 m (15 ft)	kg					*4810	*4810	*4190	*4190	*3860	3330	*3460	2270	9.24
	lb					*10600	*10600	*9240	*9240	*8510	7340	*7630	5000	(30.3)
3.0 m (10 ft)	kg		*9730	*9730	*6240	*6240	*4860	4670	*4150	3200	3510	2090	9.52	
	lb		*21450	*21450	*13760	*13760	*10710	10300	*9150	7050	7740	4610	(31.2)	
1.5 m (5 ft)	kg		*9500	*9500	*7650	6790	*5560	4370	*4490	3050	3450	2040	9.52	
	lb		*20940	*20940	*16870	14970	*12260	9630	*9900	6720	7610	4500	(31.2)	
Ground Line	kg		*9890	*9890	*8460	6390	*6050	4140	*4720	2920	3590	2120	9.24	
	lb		*21800	*21800	*18650	14090	*13340	9130	*10410	6440	7910	4670	(30.3)	
-1.5 m (-5 ft)	kg	*8800	*8800	*12860	12390	*8530	6240	*6160	4020	*4690	2860	*3670	2360	8.66
	lb	*19400	*19400	*28350	27320	*18810	13760	*13580	8860	*10340	6310	*8090	5200	(28.4)
-3.0 m (-10 ft)	kg	*12230	*12230	*11440	*11440	*7900	6250	*5740	4010			*3560	2910	7.69
	lb	*26960	*26960	*25220	*25220	*17420	13780	*12650	8840			*7850	6420	(25.2)
-4.5 m (-15 ft)	kg			*8990	*8990	*6360	*6360					*2980	*2980	6.11
	lb			*19820	*19820	*14020	*14020					*6570	*6570	(20.0)

- Lifting capacity is based on SAE J1097, ISO 10567.
- Lifting capacity of the Robex Series does not exceed 75% of the tipping load with the machine on firm, level ground or 87% of full hydraulic capacity.
- The load point is a hook located on the back of the bucket.
- (*) indicates the load limited by hydraulic capacity.