

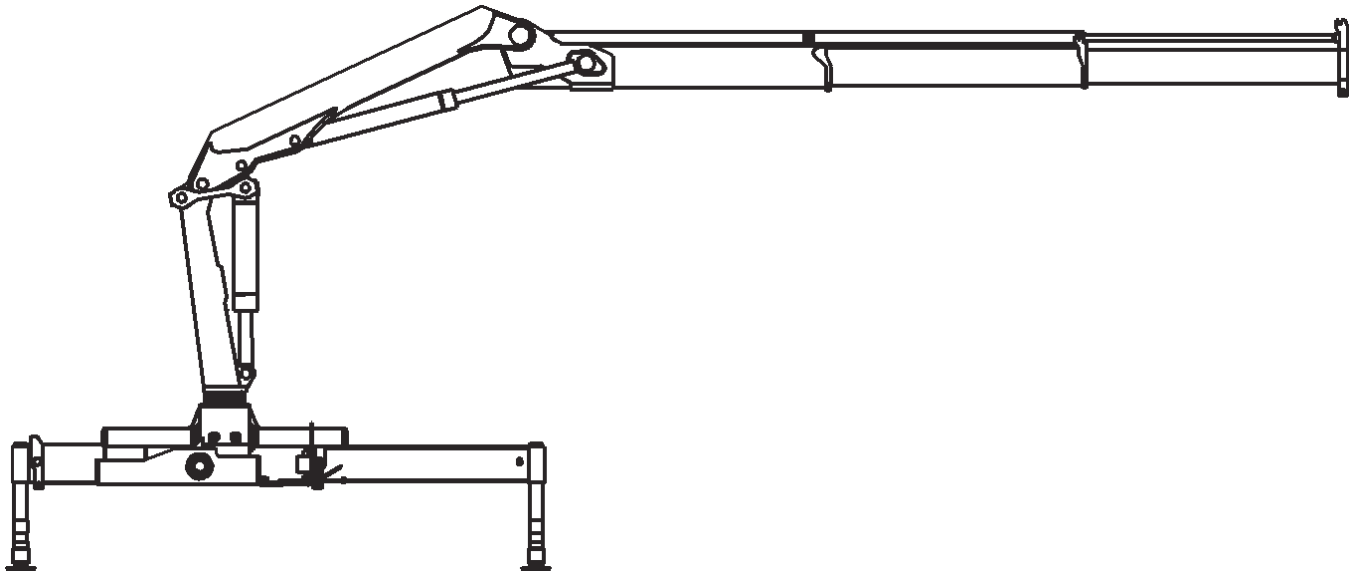

Model 12/89

Instruction Manual



NOTE

Read and understand this manual, the
IMT Operators Crane Safety Manual
and Safety Manual Supplement
before operating or maintaining your crane.

IOWA MOLD TOOLING CO., INC.

BOX 189, GARNER, IA 50438-0189

TEL: 641-923-3711

TECHNICAL SUPPORT FAX: 641-923-2424

Iowa Mold Tooling Co., Inc. is an Oshkosh Truck Corporation company.

TABLE OF CONTENTS

TABLE OF CONTENTS	2	7. Accessories	16
REVISIONS LIST	2	7.1 Use of Manual Extensions	16
Introduction	3	8. Technical Data	17
Important	3	Technical Data (Domestic)	18
1. General	4	Technical Data (Metric)	19
2. Loader Terminology	4	8.1 Loader designation	20
3. Control Valves, Symbols	5	9. Working Pressure and Pump Performance	20
4.0 Operating Instructions	6	Working pressure-12/89 (domestic)	21
4.1 Start Up	6	Working pressure-12/89 (metric)	22
4.2 Using the Loader	8	10. Service and Regular Maintenance	23
4.3 After Operation	9	10.1 First Service Overhaul	23
5. Maintenance	9	10.2 Annual Service Overhaul	23
5.1 Lubrication Intervals	9	10.3 Recommended Hydraulic Oil Types	24
5.2 Lubrication Chart	10	10.4 Recommended Lubrication Grease	24
6. Load Capacity Charts	11	11. The Hydraulic System	25
6.1 Capacity Chart-12/89K1	11	11.1 The Hydraulic System-Standard	25
6.2 Capacity Chart-12/89K2	12	11.2 Description of the Hydraulic System	26
6.3 Capacity Chart-12/89K3	13	11.3 Load Moment Limitation	26
6.4 Capacity Chart-12/89K4	14	12. Hoses and Hydraulic Pipes	26
6.5 Manual Extensions	15	13. Bleeding of Cylinders	27
		14. Repair	27

REVISIONS LIST

DATE	LOCATION	DESCRIPTION OF CHANGE
20001201	PG 11-14 PG 15 PG 18-19 PG 20	REPLACE CPS W/"K" VERSIONS VS. "H" CHG MODELS FROM "H" TO "K" UPDATE SPECS/TECH DATA ADD K3 TO MODEL #
20020228	PG 13	REVISED K3 CAPACITY PLACARD
20061113	PG 1	UPDATED OWNERSHIP STATEMENT

Introduction

Read through this instruction manual and ensure that all operation and maintenance personnel are familiar with its contents before operating or performing maintenance on the loader.

We recommend that the first service overhaul takes place at an authorized IMT service center after the first 20 hours of service or after one month of loader use, at the latest. This service check is important since the loader will be properly run in after 20 hours of use.

The first service overhaul should include the following:

1. Change of return filter element and high pressure filter cartridge, if any.
2. Oil level check in tank. Oil must be visible in the oil level glass of the oil tank when the loader has been folded up.
3. Overall lubrication according to the lubrication chart in section 5, Maintenance.
4. Leak check and tightening of fittings, if required.
5. Checking of working pressure and valve lead seals. The correct working pressures are stated in relevant Technical Information sheets.
6. Test of all functions while under load.
7. Checking and, if required, tightening of mounting bolts and pin connections.
8. Checking of all lock bolts and pins.

Important

A. If the operator has not parked the loader in transport position before driving off then he must make sure that the boom system cannot swing out during transport.

B. Use of incorrect or unsuitable attachments, welding onto or drilling into the structural components of the loader, or alterations to the construction will automatically invalidate the warranty.

C. If the lead seal of any of the valves is broken, the warranty is automatically invalidated.

D. Presence of any persons under the working loader is not permitted.

E. If air has entered the system, fill up the oil tank and bleed the loader before putting it back into operation.

F. The outrigger legs should be lowered just enough to raise the truck chassis 2 to 4 inches (5 to 10 cm). The tires of the truck must stay firmly on the ground and the driver must make sure that he has applied the parking brake.

G. Check that the locking devices of the outrigger beams are engaged on both sides before driving off.

1. General

This instruction manual contains a description of the loader, instructions for operation, maintenance and repair of the loader. The instruction manual includes the following sections:

Sections 1 through 8 contain general instructions for the daily operation of the loader.

Sections 9 through 14 are primarily aimed at operators, mounting and maintenance personnel and contain instructions for mounting, adjustment, inspection, and maintenance.

It is important that you familiarize yourself with the contents of this manual before putting the loader into operation. The same applies to any operators and maintenance personnel of the loader. It is also important to follow the recommended service schedules. These service overhauls aid in operational safety. They will also be of importance in the event of any warranty claims since IMT will attach great importance to whether these overhauls have been carried through by an authorized service center or not.

Due to continuous development and improvements, your loader model may have been changed slightly since the printing of this instruction manual.

2. Loader Terminology

The loader is designed as a truck mounted loader and therefore stationary mounting of the loader, mounting on agricultural tractors, special purpose vehicles and the like may only be performed according to specific agreement with IMT.

1. Suspension traverse
2. Control valve block
3. Outrigger/Stabilizer leg
4. Base
5. Rotation/Slewing cylinder
6. Mast/Column
7. Inner Boom cylinder
8. Link arm
9. Hinge pin
10. Outer/Jib cylinder
11. Inner/Main boom
12. Outer/Jib pin
13. Outer boom/Jib
14. Extension cylinder
15. Extension - 8.6" (218mm)
16. Extension - 7.4" (189mm)

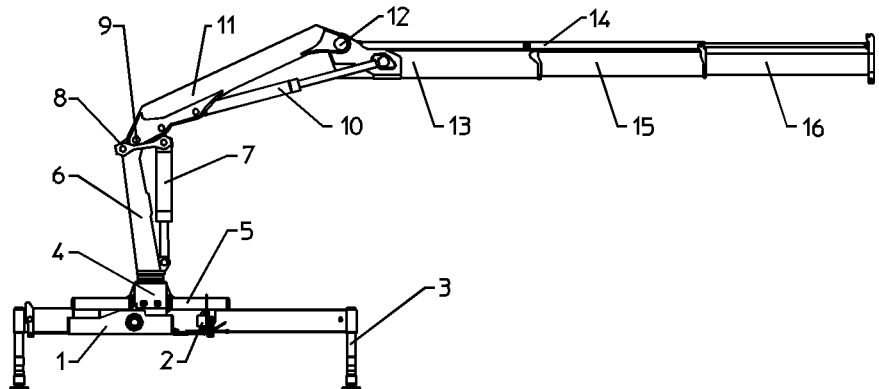

3. Control Valves, Symbols

Each control valve is labeled showing the functions of that particular valve.

Control levers should always be operated steadily and smoothly to avoid unnecessary strain on the loader.

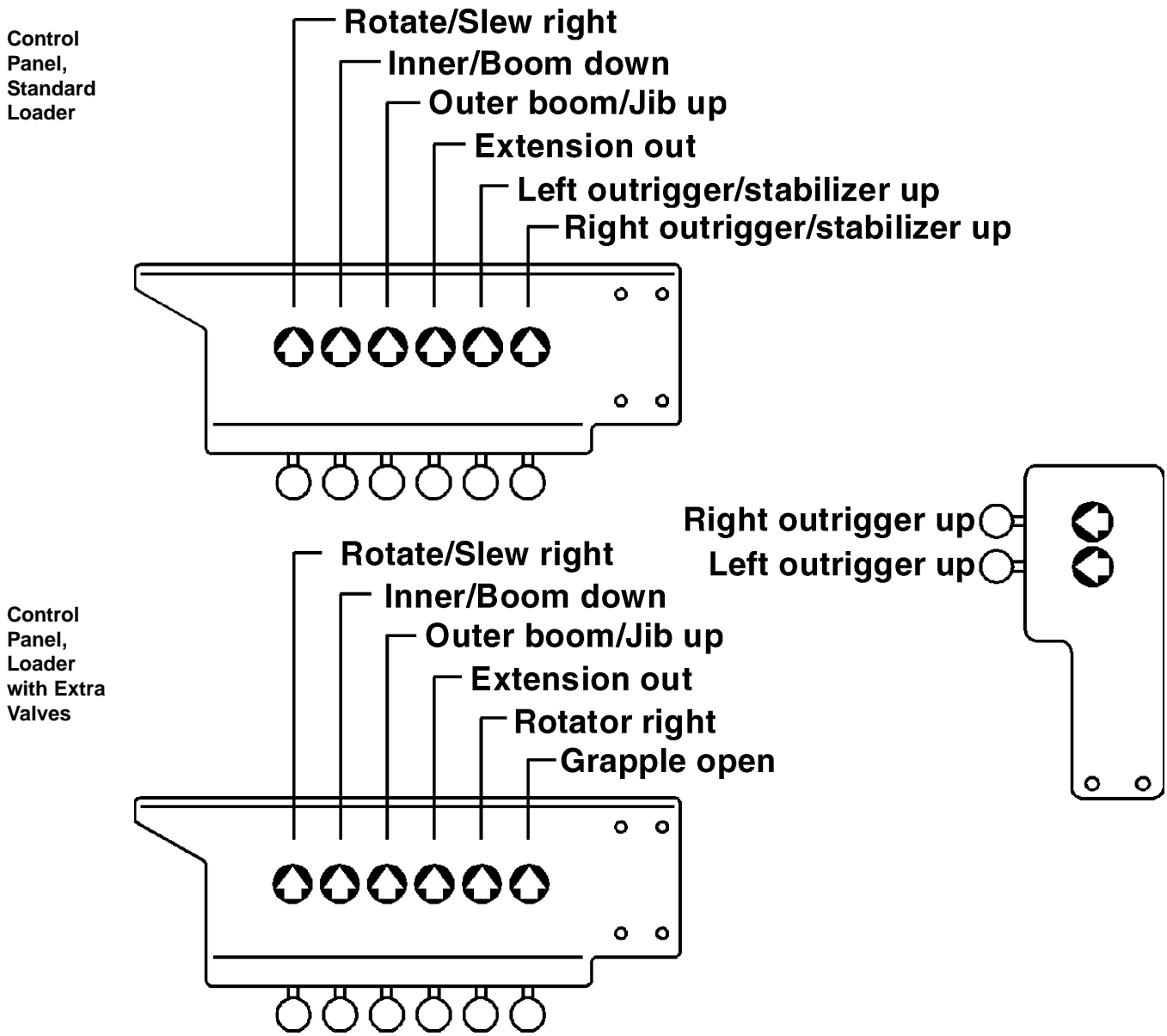

4.0 Operating Instructions

4.1 Start Up

WARNING

Prior to operation, read and understand the IMT Operators Crane Safety manual and any other safety manuals which accompanied the loader.

Before start up the operator must make sure that loader operation does not entail any unnecessary risk. Special attention must be paid to the following factors:

1. The ground must be sufficiently firm to accept the pressure from the outrigger legs. In case of heavy lifts we recommend the use of steel plates under the outrigger foot plates.
2. The ground must not be slippery (i.e., covered with ice, sand, etc.). Aftern the driver has applied the parking brake, the truck must be able to accept the horizontal forces from the loader without skidding or moving.
3. The truck must be parked in such a manner that the operator has a complete and unobstructed view of the field of operation.
4. The operator must make sure that there are no electric wires or any other obstacles within the working radius of the loader.
5. The operator must inform any unauthorized persons that entry into the working area is not permitted.

DANGER

ELECTROCUTION HAZARD
THIS CRANE IS NOT INSULATED
DEATH OR SERIOUS INJURY
WILL RESULT FROM CONTACT
OR INADEQUATE CLEARANCE

Maintain safe clearance from electrical lines.
 Allow for boom, electrical line, and loadline swaying.

This crane does not provide protection from contact with or proximity to an electrically charged conductor.

Maintain a clearance of at least 10 feet between any part of the crane, loadline or load and any electrical line carrying up to 50,000 volts (50 kV). **If electrical line voltage is unknown, assume maximum voltage and maintain a clearance of at least 45 feet.**

NOMINAL VOLTAGE, kV (Phase to Phase)	MINIMUM REQUIRED DISTANCE
to 50	10 feet
Over 50 to 200	15 feet
Over 200 to 350	20 feet
Over 350 to 500	25 feet
Over 500 to 750	35 feet
Over 750 to 1000	45 feet

70392813

General Rules:

For all work in proximity to power supply plants or overhead wires, the following general rules apply:

1. Caution must be exercised in the planning, instruction for, and execution of such work to prevent any risk or danger to persons, equipment or goods.
2. Any power supply plant, installation or wire must be considered live until the responsible power supply authority has provided a declaration that the opposite is true.
3. Any directions or guidelines from the responsible power supply authorities or public bodies must be strictly observed.

Any person or company directly responsible for the implementation of work in the proximity of overhead wires or electric power stations must make sure that all personnel involved in the execution of such work is familiar with any laws, rules or safety regulations, national as well as local, governing such work in the relevant country, territory or zone.

Not until the operator has checked the above may loader operation start.

1. Switch the change-over valve, if any, to "loader"
2. Engage the PTO at low revolutions. The engine revolution speed is regulated by means of the hand accelerator to ensure that the oil flow from the hydraulic pump corresponds to the recommended pump flow for the loader. When starting up in the cold, the oil should circulate for a few minutes before operation starts.
3. Apply the vehicle parking brake.
4. The stability of the vehicle and the loader is based on the outrigger legs being fully deployed. The loader should only be used when the outriggers are fully deployed. The operator must make sure that the vehicle has sufficient stability in the area in front of the outriggers (above the cap). The outriggers should be lowered just enough to raise the truck chassis a little in its suspensions. The tires must still have full contact with the ground.

During loading of the truck, the operator must raise the outrigger legs periodically to ensure that the truck and not the outriggers carry the weight. The outrigger legs are not designed to support this excessive load.

5. The vehicle must be positioned as close to horizontal as possible. Therefore, the driver should place the truck in as close a horizontal position as possible by means of the outrigger legs before operating the loader.
6. If the ground is not firm enough to take up the pressure of the outrigger legs, a plate, preferably steel, must be placed under the foot plates.

7. The unfolding of the loader takes place as described below:

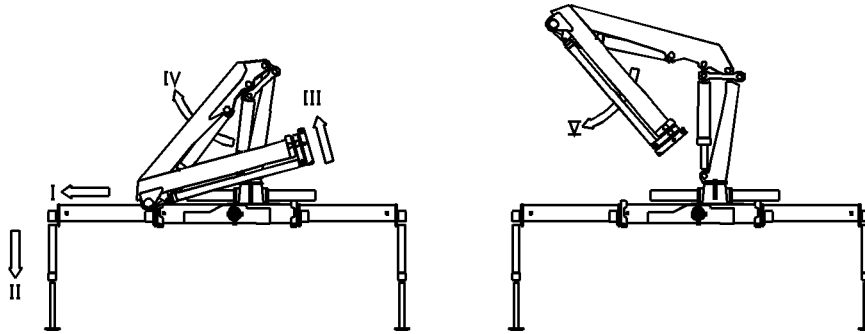

- I. Extend outrigger beams fully and check that the swivel locks are engaged.
- II. The outriggers are lowered (see items 4 & 5).
- III. The outer boom is lowered slightly to release it from the lock bracket.
- IV. The inner boom is raised and released from the bracket. The inner boom is raised slightly above horizontal, so that the outer boom may be moved freely downwards.
- V. The outer boom is raised until it is free of the base.

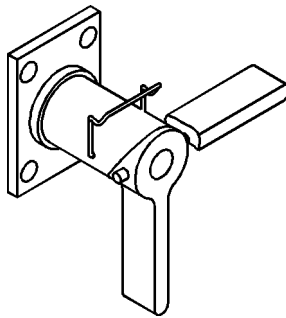

4.2 Using the Loader

After unfolding the loader, work may begin.

The lifting capacity of the loader is shown on the Capacity Chart on the loader and in this instruction manual. The capacity limits indicated must never be exceeded.

The loader is designed to lift loads vertically and therefore diagonal stresses must be avoided. Consequently the dragging of loads across the ground using the extension cylinders or the rotation system must be avoided. These functions should only be activated once the load is free of the ground. Damage caused by improper operation of the loader will not be covered by the Warranty.

If the load is extended so far that the lifting capacity is exceeded, the inner boom will slowly begin to sink. To stop this movement the load should be brought closer to the loader mast by means of the outer boom or the extension cylinder.

Never stand under the boom when the loader is working.

Please Note!

Position the truck as close to the load as possible to lift the load on the shortest possible boom.

The rotation system should be operated with care, especially when the inner boom is at an acute angle to the outer boom.

The outriggers may not be activated when the loader is working.

Never drive off with a suspended load.

4.3 After Operation

To fold up the loader:

Reverse the procedure described in item 7 in section 4.1 "Start Up". If the boom is parked on the truck platform it must be properly secured to prevent the boom from swinging out during transport.

Also, the operator should make sure that the outrigger swivel locks are in place and properly secured before driving off.

If the loader has swing-up outriggers, they must also be secured in position before driving off.

Before the vehicle is started, the PTO must be disengaged.

5. Maintenance

Careful maintenance of the loader is the best way to ensure reliable loader operation.

At regular intervals, every day or every week, depending on frequency of loader application, you should check the following:

1. The oil level in tank. Oil must be visible in the oil level glass of the tank when the loader is folded.
2. Any defects, damage or leaks should be repaired at an authorized service center as soon as discovered.
3. Loader to truck mounting hardware.
4. Slide blocks and bushings reduce friction and therefore they are naturally subject to wear. Slide blocks should be replaced when slack is detected in the boom system. Bushings should be replaced before the metal components physically touch each other.
5. Check all hoses for defects and kinks.
6. Check that hooks, straps and safety latches are in good working order.
7. Check all lock pins and bolts for wear.

Service overhauls should be undertaken according to section 10 "Service and Regular Maintenance." In case of any warranty claims later, great importance will be attached to observance of these service overhauls.

5.1 Lubrication Intervals

Base bearings:

after 20 hours of operation/1 week (whichever occurs first)

Extension system/Slide blocks:

after 50 hours of operation/1 month (whichever occurs first)

Pin connections/Bolts:

after 50 hours of operation/1 month (whichever occurs first)

Outrigger beams:

as required

Control valves and rod connections (Oil spray):

as required

The loader should be lubricated according to the lubrication chart below.

5.2 Lubrication Chart

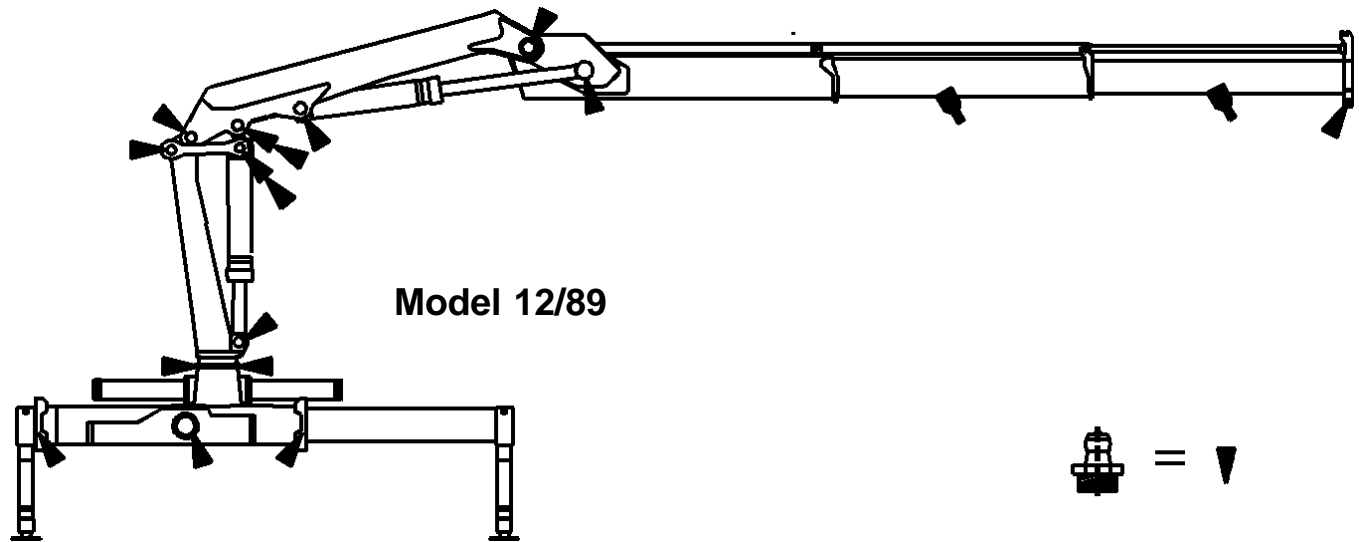

The rotation system should be activated and the loader swung from stop to stop several times within the whole rotation area at the same time as the bearings in the base are lubricated.

Hydraulic oil and lubrication grease are chosen according to the table in section 10 "Service and Regular Maintenance."

The telescopic extensions are lubricated with a special grease (Statoil Grease Way CaH 92 or Castrol ALV).

6. Load Capacity Charts

6.1 Capacity Chart-12/89K1

IMT
MATERIAL HANDLING SYSTEMS

IOWA MOLD TOOLING CO., INC.
BOX 189 • GARNER • IA • 50438 • 641-923-3711

**Model
12/89K1**

- Working loads will be limited to those shown. Deduct the weight of load handling devices.
- Before lift is made, stability must be checked per SAE J765A.

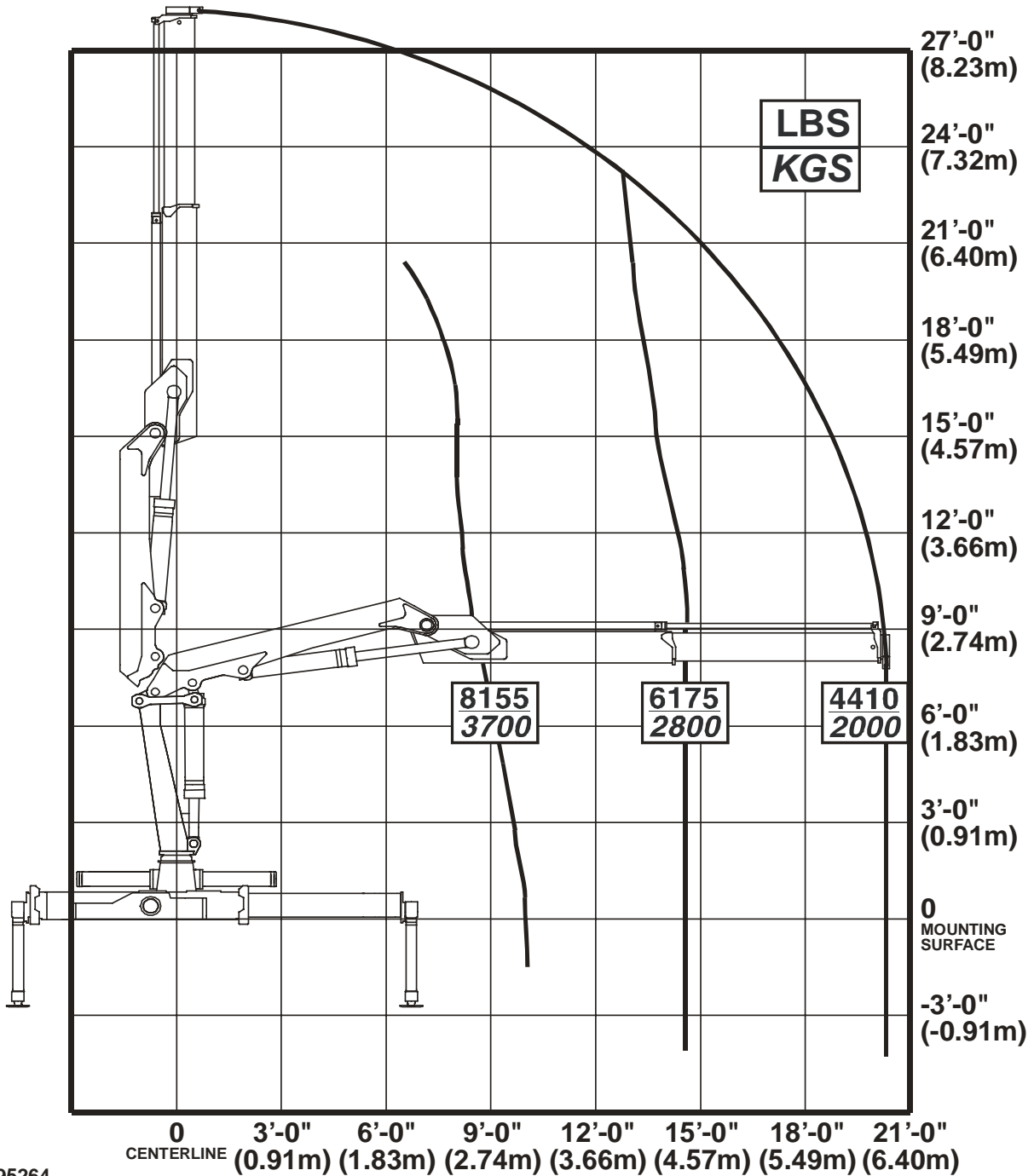

70395264

6.2 Capacity Chart-12/89K2

IMT
MATERIAL HANDLING SYSTEMS

IOWA MOLD TOOLING CO., INC.
BOX 189 • GARNER • IA • 50438 • 641-923-3711

**Model
12/89K2**

- Working loads will be limited to those shown. Deduct the weight of load handling devices.
- Before lift is made, stability must be checked per SAE J765A.

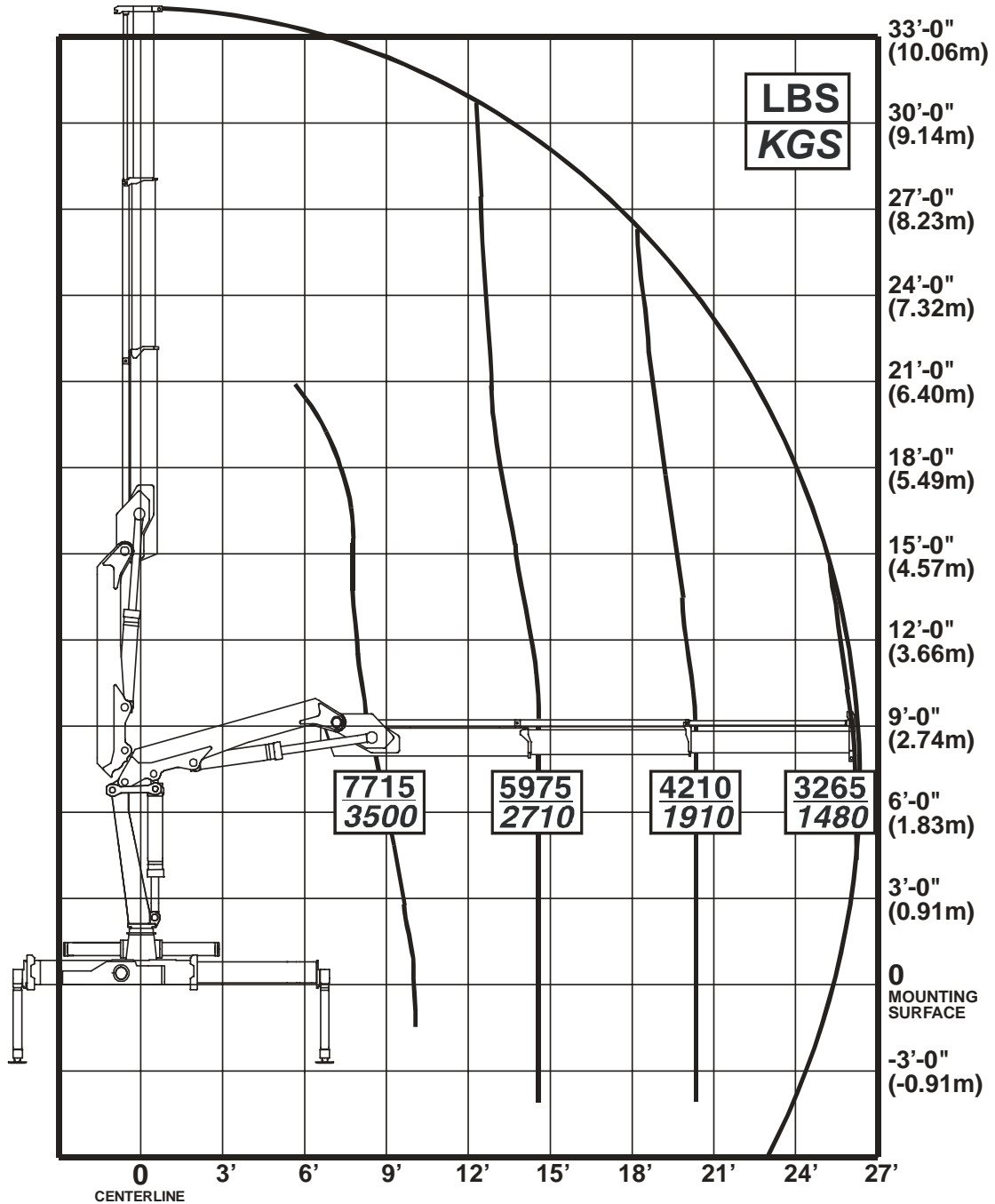

70395265

6.3 Capacity Chart-12/89K3

IMT
MATERIAL HANDLING SYSTEMS

IOWA MOLD TOOLING CO., INC.
BOX 189 • GARNER • IA • 50438 • 641-923-3711

**Model
12/89K3**

- Working loads will be limited to those shown. Deduct the weight of load handling devices.
- Before lift is made, stability must be checked per SAE J765A.

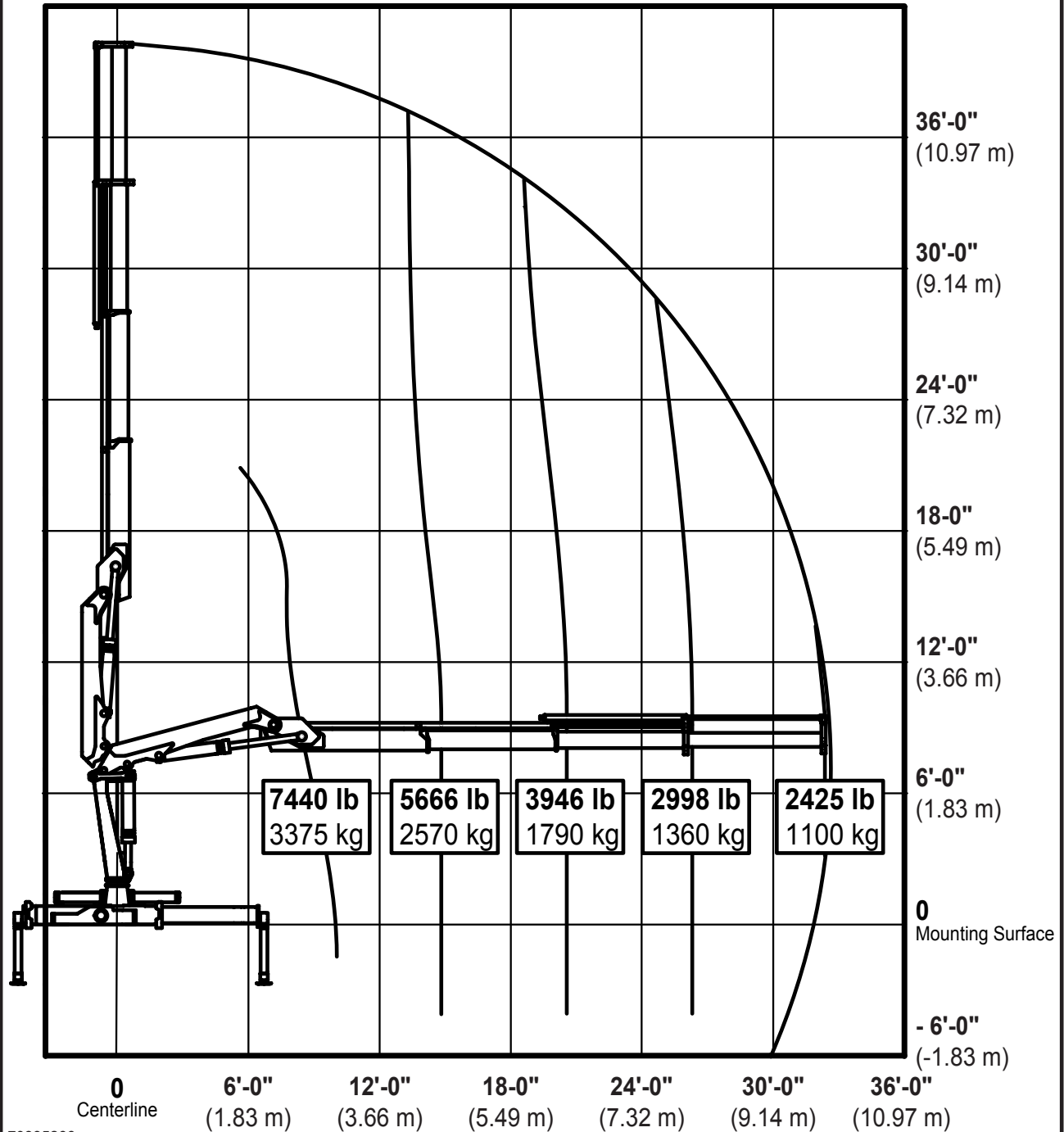

70395266

6.4 Capacity Chart-12/89K4

IMT
MATERIAL HANDLING SYSTEMS

IOWA MOLD TOOLING CO., INC.
BOX 189 • GARNER • IA • 50438 • 641-923-3711

Model 12/89K4

- Working loads will be limited to those shown. Deduct the weight of load handling devices.
- Before lift is made, stability must be checked per SAE J765A.

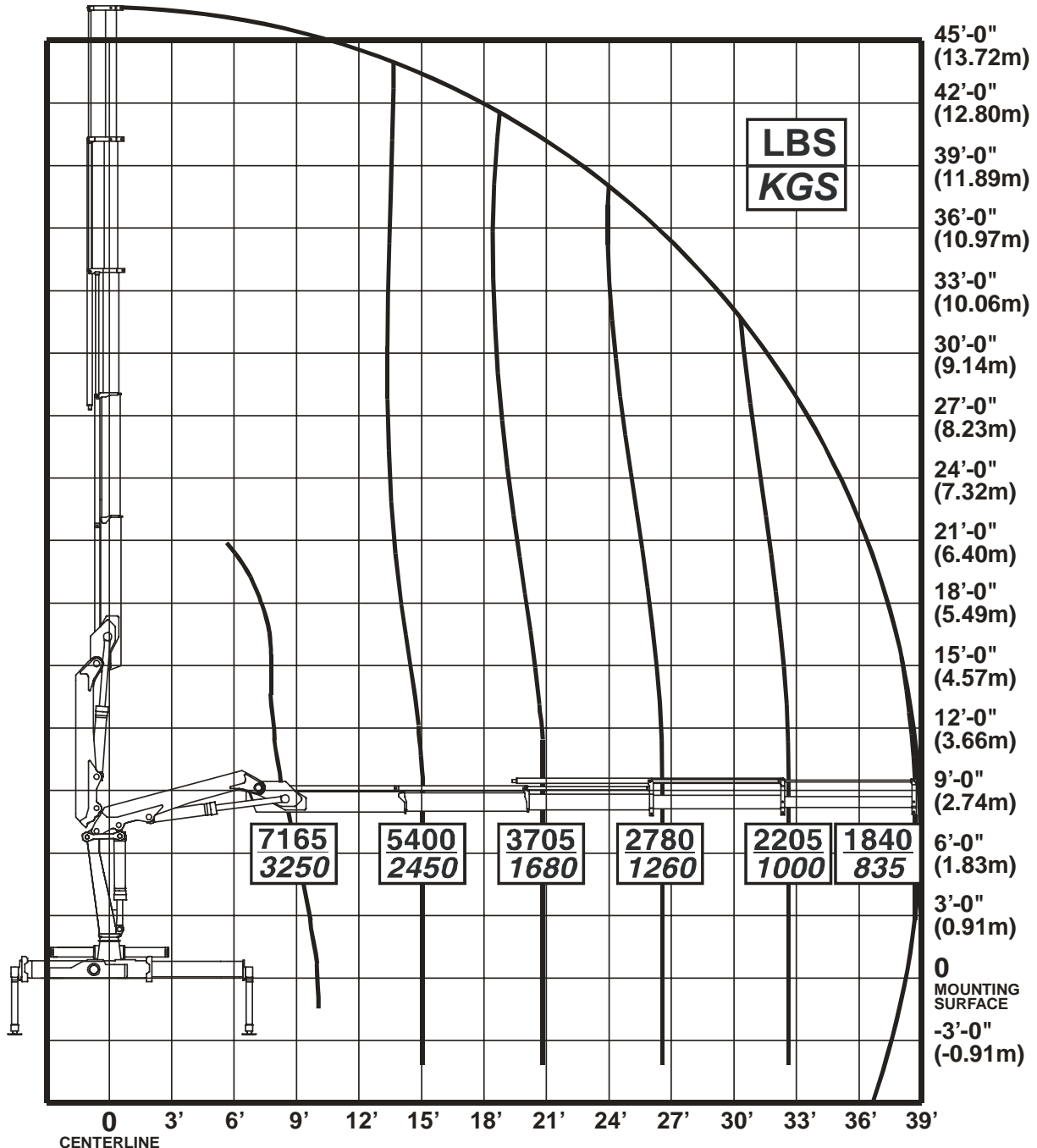

70395267

6.5 Manual Extensions

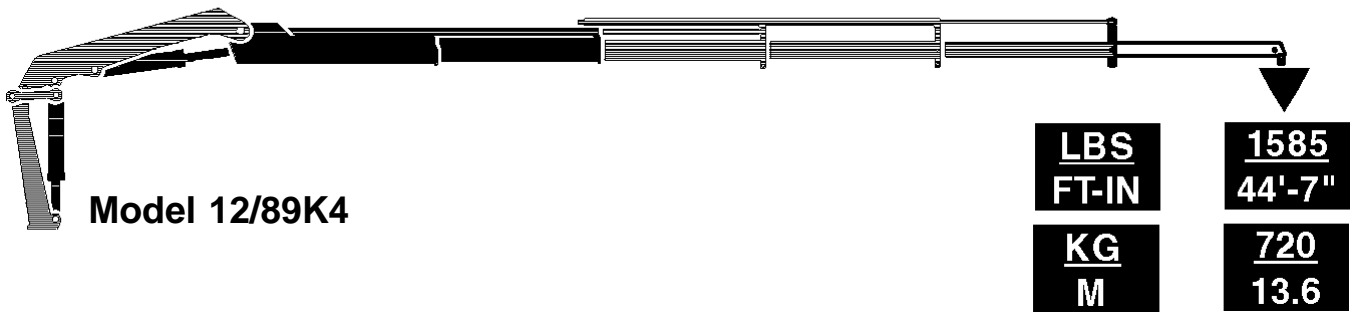
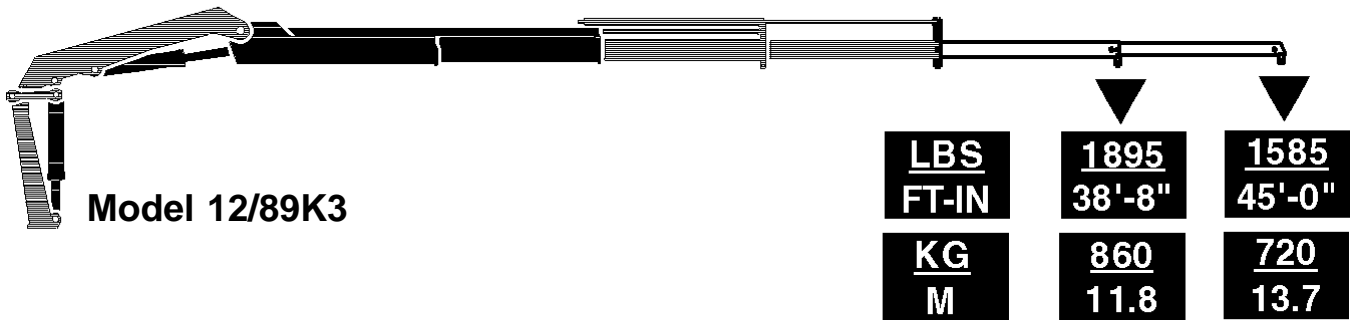
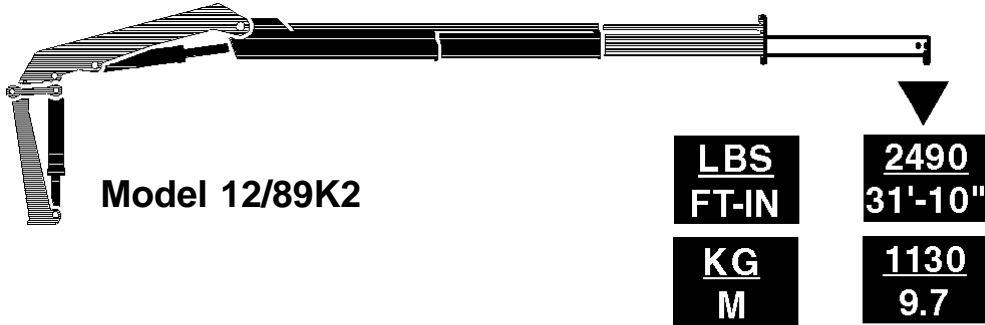

The load capacity limits shown above must never be exceeded.

NOTE

The load capacity limits indicated above for the hydraulic extensions will be reduced if the loader is mounted with manual extensions. This reduction in loader lifting capacity will correspond to the weight of the manual extensions mounted.

7. Accessories

Various accessories are available for the loader:

Manual extensions
Winch
Pallet fork
Sand bucket
Remote control

You should always consult an authorized IMT dealer or service center before mounting any kind of accessory. This also applies to equipment that you may already have in your possession.

WARNING

Welding onto or drilling into the structural components of the loader will automatically invalidate any liability on the part of IMT.

7.1 Use of Manual Extensions

When working with manual extensions, please note:

The load limits indicated for manual extension must never be exceeded. Not all extensions are protected by the safety system of the loader. Great care should be taken if the slewing system is to be activated during work with manual extensions.

If the loader is mounted with manual extensions or other accessories, the weight of those accessories must be deducted from the lifting capacity of the loader.

If the loader is mounted with several extensions and a lift requires the use of one extension only, the extension with the largest box profile should be used.

Manual extensions should only be pulled out when the outer boom is as close to horizontal as possible. If the outer boom is pointing downward when the lockbolt is removed, the extensions will slide out at an uncontrollable rate.

8. Technical Data

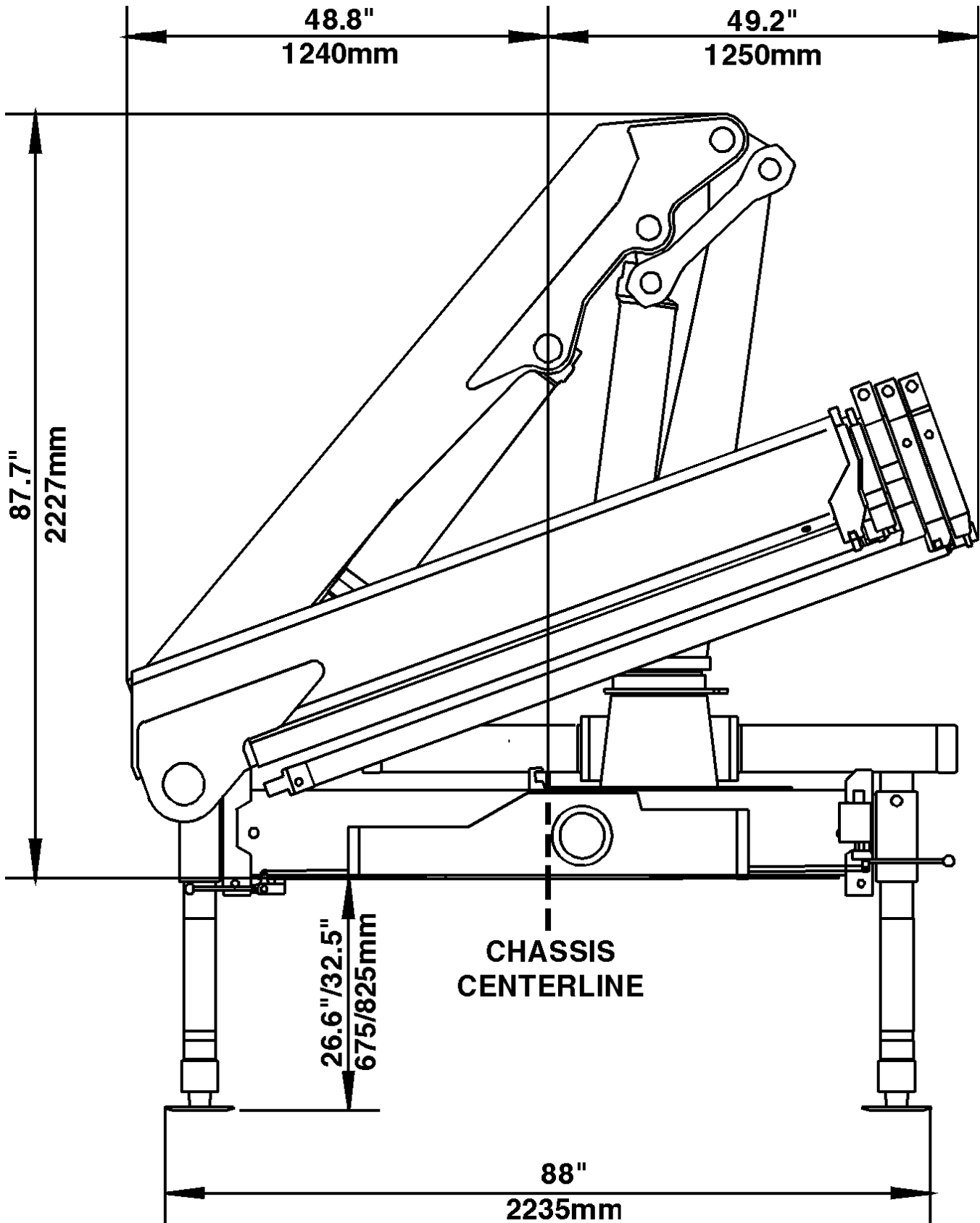

Technical Data (Domestic)

Performance	Unit	1 hyd ext	2 hyd ext	3 hyd ext	4 hyd ext
Crane Rating*	ft-lbs	89965	86975	83905	81735
Max Horiz Reach	ft & in	20'-8"	26'-3"	32'-10"	39'-0"
Max Vert Reach	ft & in	27'-10"	33'-10"	40'-0"	46'-4"
Max. Capacity	lbs	8160	7715	7440	7165
Max Cap@Max Reach	lbs	4410	3265	2425	1840
Crane Weight**	lbs	3330	3570	3850	4100
Hook Approach					
Vertical	ft & in	8'-10"	8'-8"	8'-5"	8'-2"
Horizontal	ft & in	2'-7"	2'-9"	3'-1"	3'-3"
Center of Gravity (Stored)					
Vertical	inches	27.0"	28.0"	28.1"	28.1"
Horiz (C/L Rot-Bridge)	inches	0.5"	1.0"	1.5"	2.0"
Outrigger Pad Diameter	inches	8.0"	8.0"	8.0"	8.0"
Crane Storage Height	ft & in	7'-4"	7'-4"	7'-4"	7'-4"
Mounting Space***	inches	31.5"	31.5"	31.5"	31.5"
Rotation Torque	ft-lbs	11570	11570	11570	11570
Rotation Angle	degrees	410	410	410	410
Optimum Pump Capacity	gpm (US)	13	13	13	13
System Pressure	psi	3840	3840	3840	3840
Oil Reservoir Capacity	gal	18.5	18.5	18.5	18.5
Outrigger Extension Span					
Std-mnl out/hyd dn	ft & in	15'-4"	15'-4"	15'-4"	15'-4"
Weight	lbs	430	430	430	430
Opt-hyd out/hyd dn	ft & in	18'-9"	18'-9"	18'-9"	18'-9"
Weight	lbs	750	750	750	750

Minimum Chassis Specifications

Front Axle Rating (GAWR) lbs		9000	9000	9000	9000
Rear Axle Rating (GAWR) lbs		18500	18500	18500	18500
RBM	in-lb	1,230,000	1,230,000	1,230,000	1,230,000

* Maximum Crane Rating (ft-lbs) is defined as that rated load (lbs) which when multiplied by its respective distance (ft) from centerline of rotation gives the greatest ft-lb value.

** Crane weight excluding outriggers.

*** Additional mounting space of 11" will be required to provide crane rotational clearance.

Technical Data (Metric)

Performance	Unit	1 hyd ext	2 hyd ext	3 hyd ext	4 hyd ext
Crane Rating*	ton-m	12.3	12.0	11.6	11.3
Max Horiz Reach	m	6.3	8.0	10.0	11.9
Max Vert Reach	m	8.5	10.3	12.2	14.1
Max. Capacity	kgs	3700	3500	3375	3250
Max Cap@Max Reach	kgs	2000	1480	1100	835
Crane Weight	kgs	1510	1620	1745	1860
Hook Approach					
Vertical	m	2.7	2.7	2.6	2.5
Horizontal	m	0.8	0.9	0.9	1.0
Center of Gravity (Stored)					
Vertical	mm	680	705	715	715
Horiz (C/L Rot-Bridge)	mm	15	25	40	50
Outrigger Pad Diameter	mm	200	200	200	200
Crane Storage Height	m	2.2	2.2	2.2	2.2
Mounting Space	mm	800	800	800	800
Rotation Torque	ton-m	1.6	1.6	1.6	1.6
Rotation Angle	degrees	410	410	410	410
Optimum Pump Capacity	liters/min	49	49	49	49
System Pressure	bar	265	265	265	265
Oil Reservoir Capacity	liters	70	70	70	70
Outrigger Extension Span					
Std-mnl out/hyd dn	m	4.7	4.7	4.7	4.7
Weight	kgs	196	196	196	196
Opt-hyd out/hyd dn	m	5.7	5.7	5.7	5.7
Weight	kgs	340	340	340	340

Minimum Chassis Specifications

Front Axle Rating (GAWR) lb/kg	9000/4080	9000/4080	9000/4080	9000/4080
Rear Axle Rating (GAWR) lb/kg	18500/8390	18500/8390	18500/8390	18500/8390
RBM	in-lbs	1,230,000	1,230,000	1,230,000

* Maximum Crane Rating (ton-m) is defined as that rated load (ton) which when multiplied by its respective distance (m) from centerline of rotation gives the greatest ton-m value.

** Crane weight excluding outriggers.

*** Additional mounting space of 280mm will be required to provide crane rotational clearance.

8.1 Loader designation

Different loader applications apply different types of stress to the loader structure, and consequently the loaders are divided into loading groups according to application.

As standard the 12/89K3 (3H) loader designation describes a loader with a 12 ton-meter/89000 foot-pound load moment and utilizing 3 hydraulic extensions.

If the loader is stationary, the lifting moment of the loader is reduced.

9. Working Pressure and Pump Performance

The working pressure should be set with a pressure gauge and the limits stated in the tables below must be kept.

The working pressure must be checked during the annual service overhaul and in the event of any major repairs.

The procedure for checking and setting of load-holding valves is described in Service Information. All adjustable valves must be resealed after pressure setting adjustment.

Please note that any warranty obligations on the part of IMT will be invalidated if the conditions stated in this manual are not complied with.

Working pressure-12/89 (domestic)

Working pressure on main-relief valve & port-relief valves

Function	Port	Unit	02	03	04
Main-relief valve		psi		3843	
Outrigger legs/grapple, rotator	up	A-port		2175	
	down	B-port		2175	
		A-port		2175	
		B-port		2175	
Extension cylinders	extend	A-port		P	
	retract	B-port		P	
Outer boom cylinder	Up	A-port		3988	
	down	B-port		2538	
Inner boom cylinder	down	A-port		1088	
	Up	B-port		P	
Rotation system	right	A-port		2175	
	left	B-port		2175	
Separate outrigger valve				2175	

Opening pressure on load holding valves

Inner boom cylinder				4350	
Outer boom cylinder				3988	
Extension cyl C1-V1	retract	B-port		6235	
Extension cyl C2-V2	extend	A-port		3045	
External relief valve				4205	

Pressure setting for load moment limitation

LMB				3698	
-----	--	--	--	------	--

Max. Pump performance

Pump performance 1H & 2H		gal/min		13.2	
Pump performance 3H & 4H		gal/min		10.6	

Working pressure-12/89 (metric)

Working pressure on main-relief valve & port-relief valves

Function	Port	Unit	02	03	04
Main-relief valve		MPa		26.5	
Outrigger legs/grapple, rotator	up	A-port		15.0	
	down	B-port		15.0	
		A-port		15.0	
		B-port		15.0	
Extension cylinders	extend	A-port		P	
	retract	B-port		P	
Outer boom cylinder	Up	A-port		27.5	
	down	B-port		17.5	
Inner boom cylinder	down	A-port		7.5	
	Up	B-port		P	
Rotation system	right	A-port		15.0	
	left	B-port		15.0	
Separate outrigger valve				15.0	

Opening pressure on load holding valves

Inner boom cylinder				30.0	
Outer boom cylinder				27.5	
Extension cyl C1-V1	retract	B-port		43.0	
Extension cyl C2-V2	extend	A-port		21.0	
External relief valve				29.0	

Pressure setting for load moment limitation

LMB				25.5	
-----	--	--	--	------	--

Max. Pump performance

Pump performance 1H & 2H		l/min		50.0	
Pump performance 3H & 4H		l/min		40.0	

1 MPa = 10 bar

10. Service and Regular Maintenance

10.1 First Service Overhaul

We recommend that the first service overhaul takes place at an authorized IMT service center after the first 20 hours of service or after one month of loader use at the latest. This service check is rather important since the loader will be properly run in after 20 hours of use.

The first service overhaul should include the following:

1. Change of return filter element and high pressure filter cartridge, if any.
2. The oil level in tank. Oil must be visible in the oil level glass of the oil tank when loader is folded.
3. Overall lubrication according to the lubrication chart in section 5 "Maintenance".
4. Leak check and tightening of fittings, if required
5. Checking of working pressure and lead seals. The correct working pressures are stated in relevant Technical Information sheets.
6. Test of all functions under load.
7. Checking and, if required, tightening of mounting bolts and pin connections.
8. Checking of all lock bolts and pins.

10.2 Annual Service Overhaul

Once a year the loader should be given a main service overhaul at an authorized IMT service center. The loader should be thoroughly checked and special attention should be paid to the following items:

1. Change of hydraulic oil.
2. Change of return filter element and high pressure filter cartridge, if any.
3. Cleaning or replacement of air filter.
4. Checking of working pressure and valve lead seals.
5. Idling pressure check.
6. Test of all functions under load.
7. Checking of slide blocks and bearing bushings for wear and, if required, replacement of the same.
8. Check of hydraulic hoses.
9. Leak check and tightening of all connections.
10. Check of pump and transmission.
11. Check of loader base to chassis mounting hardware.
12. Checking of all bolt connections and tightening, if required.
13. Overall checking of loader structure for damage. Any damage found should be repaired immediately.
14. Checking of all bolts and lock plates.

10.3 Recommended Hydraulic Oil Types

Oil Brand	Oil Type	Low Temp Oil Type
BP	Bartran HV 32	Bartran HV 22
Castrol	Hyspin AWS 32	Hyspin AWH 32
ESSO	Nuto H 32	Univis N 22
Kuwait petroleum Q8	Harmony 32 AW	Hydraulic L 32
Mobil	DTE 13	DTE 11
Shell	Tellus S 32	Tellus T 32
Statoil	Hydra Way HM 32	Hydra Way HV 22
Texaco	Rando HD 32	Rando HDZ 32

10.4 Recommended Lubrication Grease

Grease Brand	Grease for Bearings
BP	Energrease L52
Castrol	LM Grease
ESSO	MP Grease / Beacon EP 2
Mobil	Mobilux EP 2 or Mobilgrease HP
Shell	Retinox MS
Statoil	UniWay EP 2
Texaco	Multifak All Purpose EP 2

Grease containing molybdenum disulphide must not be used.

Grease Brand	Grease for Telescopic Extensions
Statoil	Grease Way CaH 92
Castrol	ALV

11. The Hydraulic System

11.1 The Hydraulic System-Standard

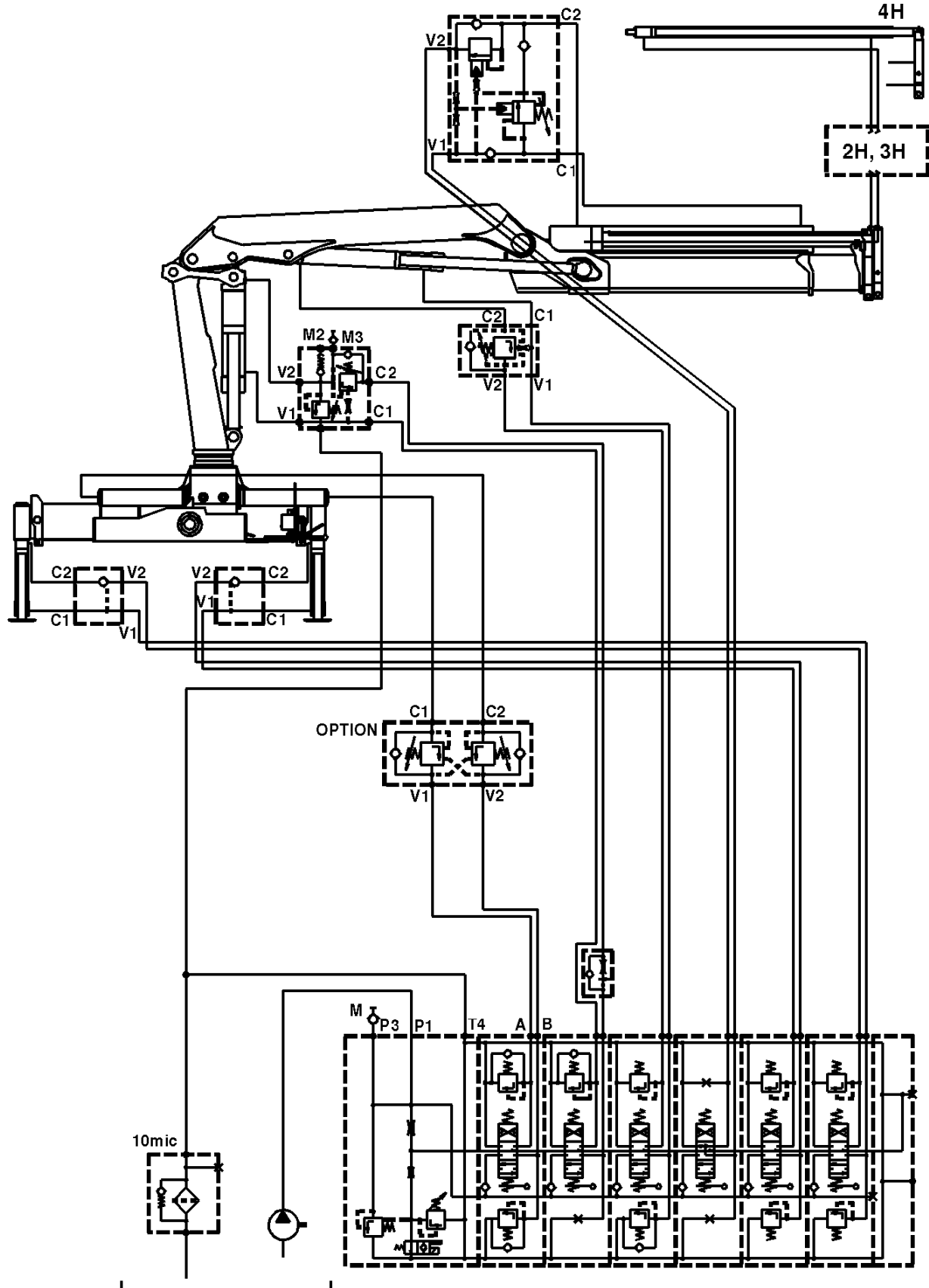

11.2 Description of the Hydraulic System

The valve block of the loader is of the “stack” type, i.e., it is made up of a number of separate control valves. This ensures great flexibility and low Maintenance costs.

A main relief valve is fitted in the inlet section of the valve block to ensure that the oil pressure in the pump line does not exceed the permissible limit. This valve is adjustable and must always remain sealed.

Port relief valves are mounted at the ports of the individual control valves to limit the pressure in the individual circuits. Normally the port relief valves will be pre-set and not adjustable.

The inner, outer, and extension cylinders are mounted with load holding valves with the following functions:

1. Protection of cylinders against excessive pressure.
2. Checking of the lowering speed of the boom.
3. Maintain the boom in position during operations where a fixed boom position is required.
4. To lock the boom and maintain the load in position in case of hose or pipe rupture.

The outrigger legs are equipped with a piloted check valve that locks the cylinder in case of damage to the hydraulic system.

Important

The main relief valve and the load holding valve on the boom cylinder are sealed. If these seals are broken or removed the warranty will automatically be invalidated. Therefore, it is in your own interest to have the lead seals checked from time to time and to make sure that they are replaced by an authorized IMT service center should they be damaged.

Any modification or alteration to the hydraulic system must be in accordance to specific agreement with IMT and such alterations should always take place at an IMT service point.

11.3 Load Moment Limitation

The loader is equipped with a load moment limitation system (LMB). This system ensures that the permissible load moment is never exceeded, irrespective of the operator’s actions. It is important to keep in mind that the LMB system does not necessarily ensure sufficient vehicle stability. Before use, the operator must make sure the vehicle is stable over the entire operational range of the loader. See RCL Safety System manual for complete description.

12. Hoses and Hydraulic Pipes

The hoses must comply with the SAE R100 2AT standard.

The pipes are manufactured in St.35.4C-NBK.

The following dimensions are used:

- ∅ 8 x 1
- ∅ 12 x 1.5
- ∅ 18 x 2

13. Bleeding of Cylinders

If air has entered into the hydraulic system the loader is bled as follows:

1. Raise and lower each outrigger leg twice
2. The rotation cylinders are bled by swinging the loader from stop to stop 2-3 times.
3. The inner boom cylinder is fully extended and retracted twice
4. The outer boom cylinder is extended and retracted twice with the inner boom pointing upwards and twice with the inner boom pointing downwards
5. The extension cylinders are extended and retracted twice with the outer boom cylinder pointing almost vertically upwards and then twice with the outer boom cylinder pointing almost vertically downwards.

14. Repair

If you discover defects, damage or leaks, they should be repaired as soon as possible. Always take your repairs to an authorized IMT service center. Repairs to the hydraulic system can only be made by an authorized service center.

When you order spare parts for your loader, please state:

Loader type

Loader serial number

This information may be found in this instruction manual or stamped into the metal plate on the back side of the loader column.

IOWA MOLD TOOLING CO., INC.

BOX 189, GARNER, IA 50438-0189

TEL: 641-923-3711

TECHNICAL SUPPORT FAX: 641-923-2424