

Articulating Cranes

3000

Technical Specifications

Material Handling Systems

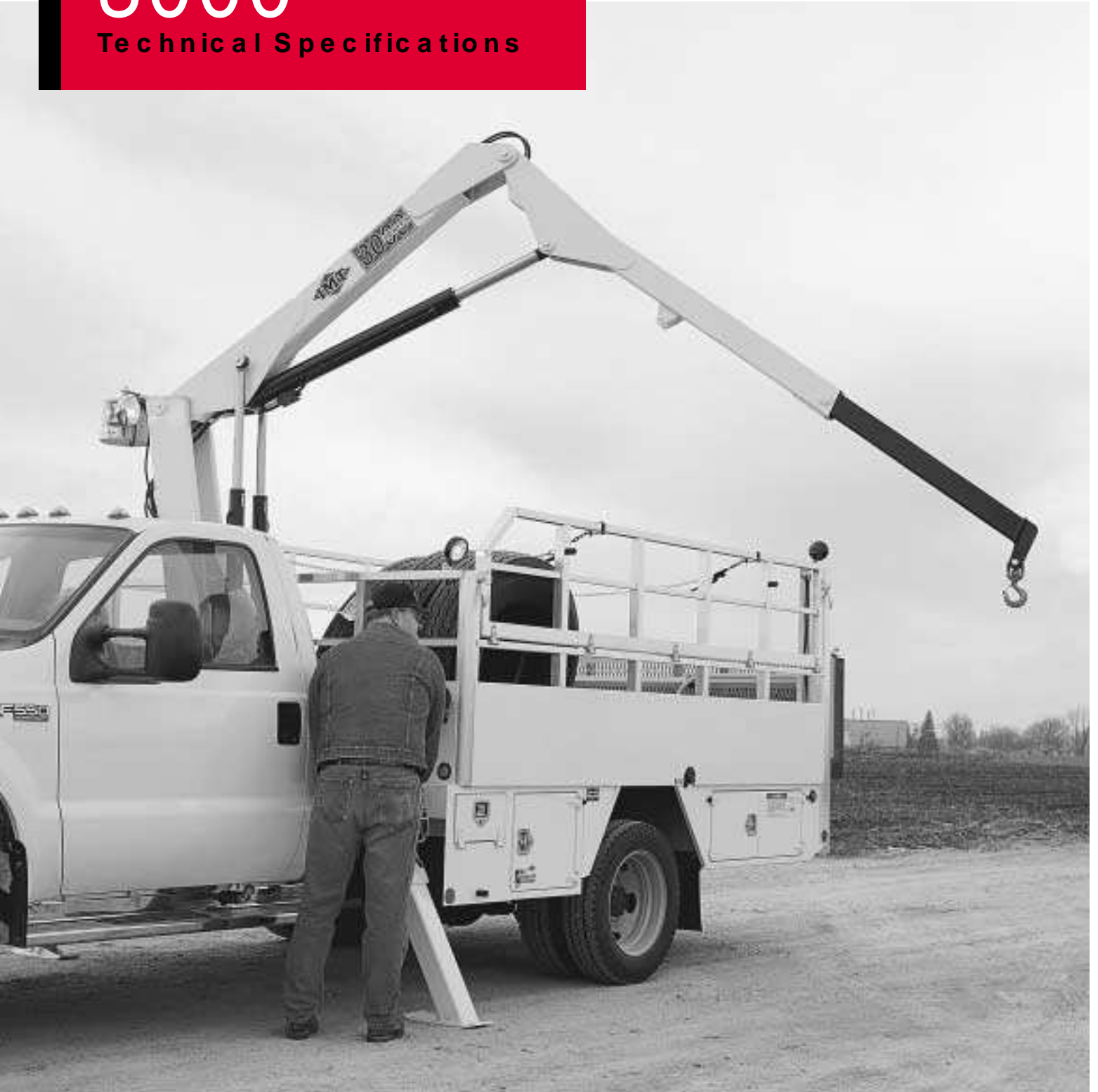



Specifications	1 Hydraulic
Crane Rating (ANSI B30.22)*	30,000 ft-lb (4.2 tm)
Maximum Crane Rating *	30,150 ft-lb (4.2 tm)
Horizontal Reach from centerline of rotation	15'0" (4.6 m)
Hydraulic Extension	36" (91.4 cm)
Manual Extension	None
Vertical Reach from mounting surface from ground/34" frame height	20'7" (6.3 m) 23'5" (7.1 m)
Crane Weight	1,825 lbs. (827.8 kg)
Outrigger Span	10'5" (3.2 m)
Outrigger Pads	10" x 10" (25.4 cm x 25.4 cm)
Crane Storage Height from mounting surface from ground/34" frame height	6'2" (1.9 m) 9'0" (2.7 m)
Mounting Space Required**	23-1/2" (59.7 cm)
Rotational Torque	4,920 ft-lb (0.7 tm)
Optimum Pump Capacity	5 U.S. gpm (18.9 L/min)
System Operating Pressure	2,700 psi (186.2 bar)
Oil Reservoir Capacity	10 U.S. gallons (37.9 L)
Hook Approach horizontal from centerline of rotation vertical from mounting surface	34" (86.4 cm) 5'10" (1.8 m)

* Maximum crane rating (ft-lb) is defined as the rated load (lbs.) which when multiplied by its respective distance (ft.) from centerline of rotation gives the greatest ft-lb value. ANSI B30.22 crane rating (ft-lb) is the rated load (lb) x the respective distance (ft.) from centerline of rotation with all extensions retracted and the inner and outer booms in a horizontal position.

** Allow an additional 2" between the cab and crane base for swing clearance.

Capacity Charts

1 Hydraulic Extension

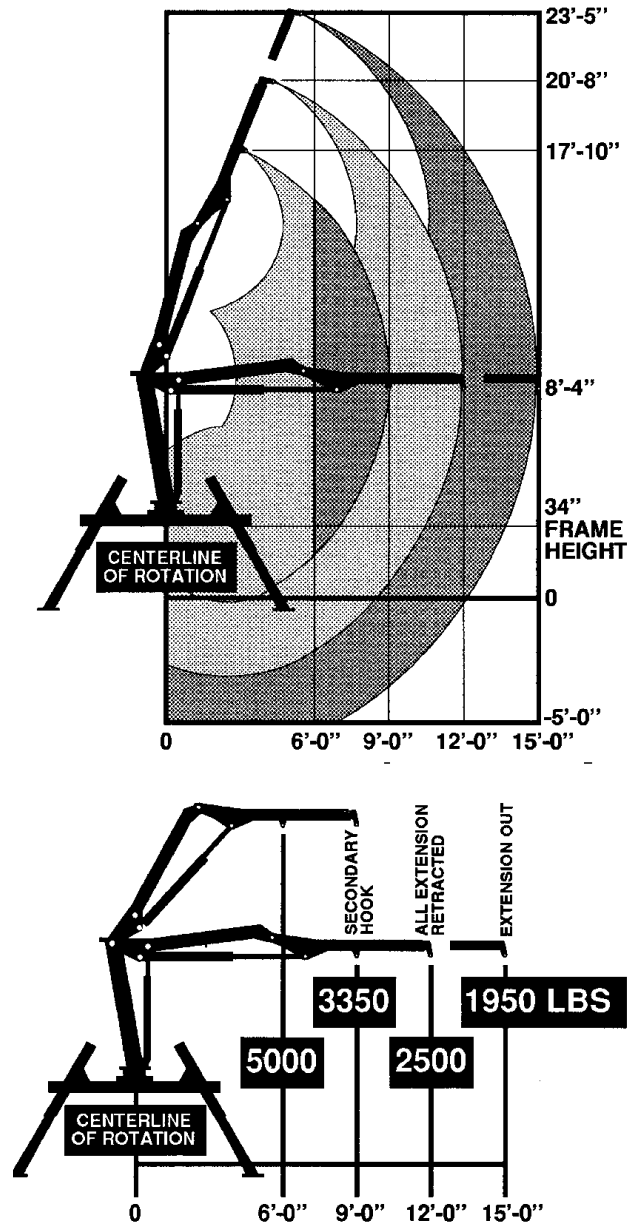

- Capacities (for above charts) through geometric range are limited to those shown in horizontal position.
- Loads shown are based on crane structural or hydraulic capability. Before lift is made, stability must be checked per SAE J765A.
- Working loads will be limited to those shown. Deduct the weight of load-handling devices.
- Winch-lifting capacity is limited to those shown. Maximum 2,500 lbs. for one-part line.

3000 Articulating Crane

Performance Characteristics

Rotation	400° (7.0 rad)	35 seconds
Inner Boom Elevation	-45° to +75° (-0.8 to +1.3 rad)	13 seconds
Outer Boom Articulation	139° (2.4 rad)	14 seconds
Extension	36" (91.4 cm)	8 seconds
Outrigger Stroke	28-3/4" (0.7 m)	5 seconds

Power Source

Integral mounted hydraulic pump and PTO application. Other standard power sources may be utilized. Minimum power required is 10 horsepower.

Cylinder Holding Valves

The holding sides of all standard cylinders are equipped with integral mounted holding or counterbalance valves to prevent sudden cylinder collapse in case of hose or other hydraulic failure. The inner cylinders have single pilot-operated counterbalance valves while the outer and extension boom cylinders have double counterbalance valves. The counterbalance valve serves several functions. First, it is a holding valve. Second, it is so constructed that it will control the lowering function and allow that motion to be feathered while under load. Finally, if a hose breaks the only oil loss will be that in the hose.

Rotation System

Rotation of the crane is accomplished through a turntable bearing with external worm gear, powered by a high-torque hydraulic motor through a self-locking work. Total gear reduction is 73:1.

Hydraulic System

The hydraulic system is an open-centered, full-pressure system, requiring 5 gpm optimum oil flow at 2,700 psi. Six-spool, stack-type control valve with dual operational handles located at both sides of crane for convenient operation. System includes hydraulic oil reservoir, suction-line strainer, pump, 8-section control valve, return-line filter and all hoses and fittings.

Minimum Chassis Specifications

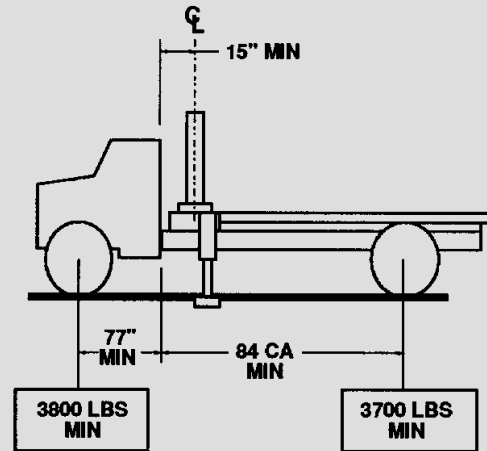

Crane Mount	Behind Cab
Crane Working Area	360° (6.3 rad)
Chassis Style	Conventional Cab
Front Axle Rating (GAWR)	5,000 lbs. (2,268 kg)
Rear Axle Rating (GAWR)	9,500 lbs. (4,309.2 kg) Single Axle
Wheelbase	161" (4.1 m)
Cab-To-Axle	84" (2.1 m)
Outrigger Width Required	10'5" (3.2 m)
Resistance To Bending Moment	360,000 in-lb (4148 kg-m)
Frame Section Modulus	10in ³ (168.9 cm ³)
Frame Yield Strength	36,000 psi (248 N/mm ²)
Minimum Finished Unit Weight To Maintain Vehicle Stability	
Front Axle	3,800 lbs.* (1,723.7 kg)
Rear Axle	3,700 lbs.* (1,678.32 kg)
Total Finished Unit Weight	7,500 lbs. (3,402 kg)

* Allows lifting full-capacity load in a 360° arc when crane is installed immediately behind the cab. Great care should be taken when swinging the load from rear of vehicle to front of vehicle since the front axle springs will compress, thus affecting the levelness of the vehicle.

Notes

1. GAWR means Gross Axle Weight Rating and is dependent on all components of the vehicle such as axles, tires, wheels, springs, brakes, steering and frame strength meeting the manufacturer's recommendations. Always specify GAWR when purchasing a truck.
2. Minimum axle requirements may increase with use of diesel engines, longer wheelbase or service bodies. Contact the factory for further information.
3. Weight distribution calculations are required to determine final axle loading.
4. All chassis and crane combinations must be stability-tested to ensure stability per ANSI B30.22.



3000 Articulating Crane

Geometric Configurations

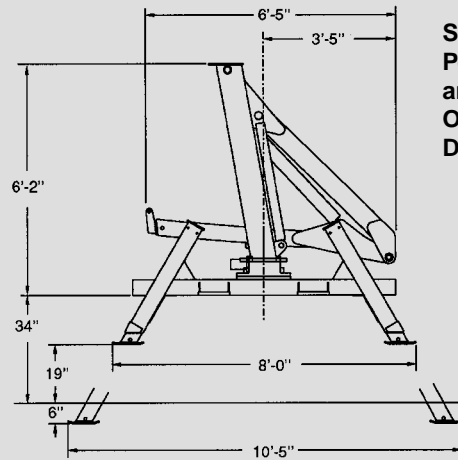
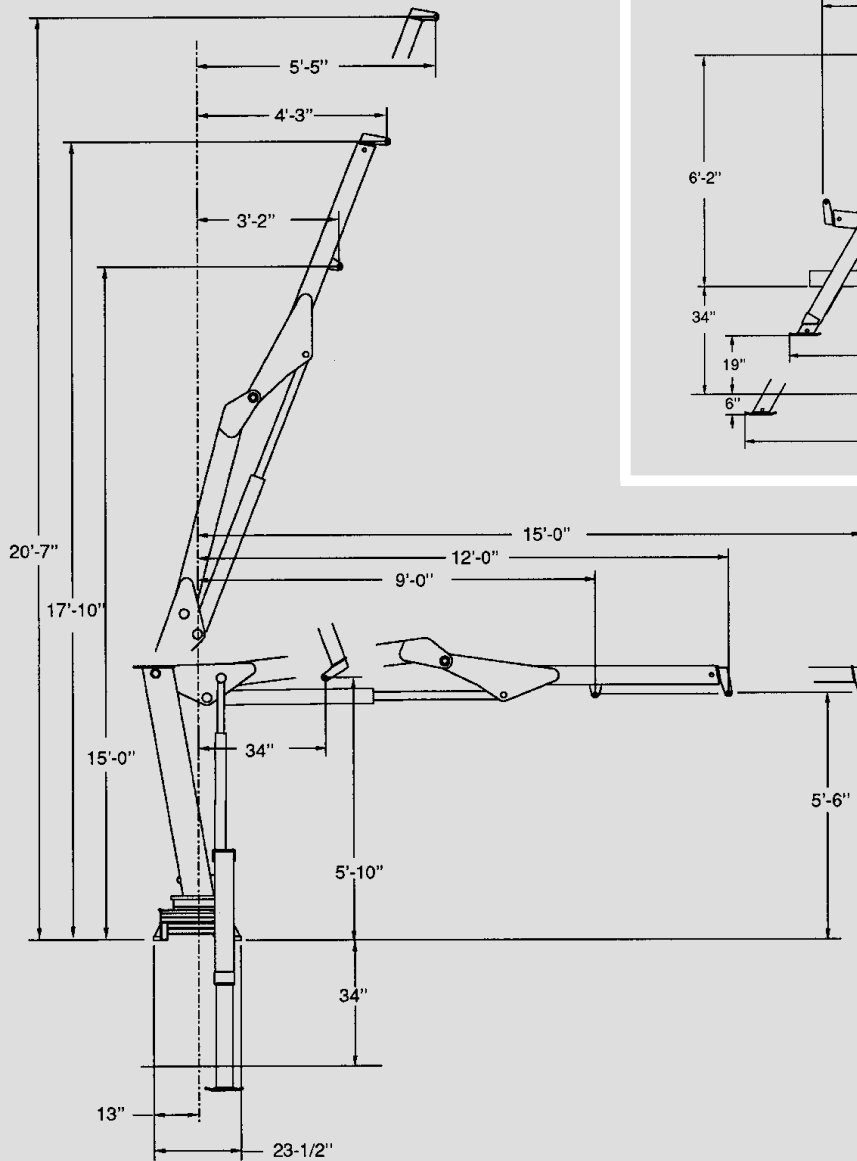

Stowed Position and Outrigger Dimensions



Iowa Mold Tooling Co., Inc.

500 Highway 18 West
 P.O. Box 189
 Garner, Iowa 50438-0189
 (515) 923-3711
 Fax: (515) 923-6063
 Web Site: www.imt.com

(800) 247-5958

Manufacturer's Limited Warranty Coverage

Products manufactured by IMT are warranted to be free from defects in material and workmanship, under proper use, application and maintenance in accordance with IMT's written recommendations, instructions and specifications as follows:

1. Ninety (90) days: labor on IMT workmanship from the date of shipment to the end user.
2. One (1) year: original IMT parts from the date of shipment to the end user.

IMT reserves the right to change specifications and design without notice.