Manual # 99904932

60/427 Technical Specifications

Revision Date 20111214



IOWA MOLD TOOLING CO., INC.

PO Box 189

Garner, IA 50438

Tel: 641-923-3711 FAX: 641-923-2424

Website: <http://www.imt.com>

Copyright © 2011 Iowa Mold Tooling Co., Inc.
All rights reserved

No part of this publication may be reproduced, stored in a retrieval system, or transmitted in any form or by any means, electronic, mechanical, photocopying, recording or otherwise without the prior written permission of Iowa Mold Tooling Co., Inc.

Iowa Mold Tooling Co., Inc. is an Oshkosh Corporation company.

Printed on 14 December, 2011

Courtesy of Crane.Market

Contents

Revisions	ii
-----------------	----

Technical Data and Charts **3**

60/427 Technical Specifications	3
60/427 Pressure Settings	5
60/427 K4 Capacity Chart	7
60/427 K6 Capacity Chart	8
60/427 Dimensional Drawing	9
Stabilizer Dimensions, Fixed Legs, 60/427	10
Stabilizer Dimensions, Hydraulic Swing-Up Legs, 60/427	11
60/427 Swing Clearance	12

Hydraulic Schematics **13**

60/427 Hydraulic Schematic, Single-Circuit Fixed	14
60/427 Hydraulic Schematic, Dual-Circuit Fixed	15
60/427 Hydraulic Schematic, Loader Functions	16

Revisions

DATE	LOCATION	DESCRIPTION
20110401		Added 60/427K4 Capacity Chart
20111214	Specifications	ECN 11628 - Updated stabilizer wording.

CHAPTER 1

Technical Data and Charts

In This Chapter

60/427 Technical Specifications	3
60/427 Pressure Settings	4
60/427 K4 Capacity Chart	7
60/427 K6 Capacity Chart	8
60/427 Dimensional Drawing	9
Stabilizer Dimensions, Fixed Legs, 60/427	10
Stabilizer Dimensions, Hydraulic Swing-Up Legs, 60/427	11
60/427 Swing Clearance	12

60/427 Technical Specifications

60/427	2-Hyd	3-Hyd	4-Hyd	5-Hyd	6-Hyd	7-Hyd	8-Hyd
Crane Rating*	409,390 ft lb (56.6 tm)	398,540 ft lb (55.1 tm)	391,305 ft lb (54.1 tm)	386,240 ft lb (53.4 tm)	382,625 ft lb (52.9 tm)	378,285 ft lb (52.3 tm)	373,225 ft lb (51.6 tm)
Maximum Horizontal Reach	27' 3" (8.3 m)	34' 1" (10.4 m)	40' 8" (12.4 m)	48' 3" (14.7 m)	51' 10" (15.8 m)	59' 9" (18.2 m)	67' 7" (20.6 m)
Maximum Vertical Reach	36' 5" (11.1 m)	43' 0" (13.1 m)	49' 6" (15.1 m)	56' 9" (17.3 m)	61' 8" (18.8 m)	69' 3" (21.1 m)	76' 9" (23.4 m)
Maximum Capacity	27,845 lb (12,630 kg)	27,115 lb (12,300 kg)	26,765 lb (12,140 kg)	25,970 lb (11,780 kg)	26,610 lb (12,070 kg)	25,245 lb (11,450 kg)	24,715 lb (11,210 kg)
Max Cap @ Max Reach	15,235 lb (6910 kg)	11,705 lb (5310 kg)	9195 lb (4170 kg)	7295 lb (3310 kg)	6570 lb (2980 kg)	5225 lb (2370 kg)	4210 lb (1910 kg)
Crane Weight **	9735 lb (4415 kg)	10,395 lb (4715 kg)	11,055 lb (5015 kg)	11,650 lb (5285 kg)	12,050 lb (5465 kg)	12,490 lb (5665 kg)	12,930 lb (5865 kg)
Hook Approach							
Vertical	10' 6" (3.2 m)	10' 2" (3.1 m)	9' 10" (3.0 m)	9' 6" (2.9 m)	10' 2" (3.1 m)	9' 2" (2.8 m)	9' 2" (2.8 m)
Horizontal	4'-11" (1.5 m)	4'-11" (1.5 m)	4'-11" (1.5 m)	4'-11" (1.5 m)	4'-11" (1.5 m)	4'-11" (1.5 m)	4'-11" (1.5 m)
Center of Gravity - Stored							
Vertical	3' 1" (930 mm)	3' 1" (945 mm)	3' 1" (950 mm)	3' 2" (960 mm)	3' 2" (960 mm)	3' 2" (969 mm)	3' 3" (983 mm)
Horizontal (C/L RotTo Bridge)	12.1" (308 mm)	12.0" (305 mm)	12.2" (310 mm)	12.0" (306 mm)	12.3" (313 mm)	12.2" (309 mm)	12.0" (304 mm)

* Crane rating (ft-lb) is the rated load (lb) multiplied by the respective distance (ft) from centerline of rotation with all extensions retracted and the inner and outer booms in a horizontal position, per ANSI B30.22. ** Crane weight does not include stabilizers.

60/427 Specifications	
Stabilizer Pad Diameter	7.9" (200 mm)
Crane Storage Height	7' 11" (2425 mm)
Mounting Space (K2 - K5) ***	4' 4" (1325 mm)
Mounting Space (K6 - K8) ***	4' 9" (1460 mm)
Mounting Space (K6 with K6 FJ1200) ***	5' 2" (1585 mm)
Rotational Torque	50,630 ft-lb (7.0 tm)
Rotation	Continuous
Optimum Pump Performance	2X17gpm (2X65 L/min)
System Pressure	5075 psi (350 bar)
Oil Reservoir Capacity	55.5 gal (210 L)
Stabilizer Extension Span	
Standard (hydraulic out / hydraulic down)	27' 7" (8420 mm)
Weight	1,545 lb (700 kg)
*** Maximum swing clearance radius required is 3'-1" (935 mm) at 8'-9" (2660 mm) from top of chassis frame.	

Minimum Chassis Specifications	
Front Axle Rating (GAWR)	20,000 lb (9070 kg)
Rear Axle Rating (GAWR)	46,000 lb (20,865 kg)
Resistance to Bending Moment	5,700,000 in-lb (656,710 kg-m)

60/427 Pressure Settings

WORKING PRESSURE ON MAIN-RELIEF VALVE & PORT-RELIEF VALVES

VALVE BLOCK, CIRCUIT 1

Main-relief valve			5365 psi (370 bar)	
FUNCTION	DIRECTION	PORT	PORT-RELIEF VALVES	LS-PRESSURE ADJUSTMENT
Slewing system	CW	A	P	2175 psi (150 bar)
	CCW	B	P	2175 psi (150 bar)
Winch	Lift	A	P	3045 psi (210 bar)
	Lower	B	P	3045 psi (210 bar)
Boom cylinder	Up	A	5365 psi (370 bar)	5075 psi (350 bar)
	Down	B	P	41815 psi (125 bar)

VALVE BLOCK, CIRCUIT 2

Main-relief valve			5365 psi (370 bar)	
FUNCTION	DIRECTION	PORT	PORT-RELIEF VALVES	LS-PRESSURE ADJUSTMENT
Jib cylinder	Up	A	4930 psi (340 bar)	4640 psi (320 bar)
	Down	B	P	2900 psi (200 bar)
Extension	Extend	A	P	4350 psi (300 bar)
	Retract	B	P	4350 psi (300 bar)
Rotator	CW	A	4350 psi (300 bar)**	725 - 4350 psi (50-300 bar)*
	CCW	B	4060 psi (280 bar)**	725 - 4350 psi (50-300 bar)*
Grab	Open	A	P	725 - 4350 psi (50-300 bar)*
	Close	B	P	725 - 4350 psi (50-300 bar)*
Separate stabilizer valve		All		3045 psi (210 bar)

* On loaders without fly-jibs, the LS-pressure may be adjusted individually.

** On loaders without fly-jibs, it is possible to change the port-relief valves individually.

Opening Pressure on Load-Holding Valves FUNCTION	DIRECTION	OPENING PRESSURE
Planetary Gear, V1	Slewing CW	2320 psi (160 bar)
Planetary Gear, V2	Slewing CCW	2320 psi (160 bar)
Boom Cylinder C2-V2	Tilt Up	5510 psi (380 bar)
Boom Cylinder C1-V2	Tilt Down	1815 psi (125 bar)
Jib Cylinder C2-V2	Jib Up	5220 psi (360 bar)
Jib Cylinder C1-V2	Jib Down	3045 psi (210 bar)
Ext Cylinder C1-C2	Extension Retract	5510 psi (380 bar)
Ext Cylinder C2-V2	Extension Extend	3770 psi (260 bar)
Ext Cylinder C2-V1*	Extension Extend*	3480 psi (240 bar)
* Max. pressure at "Extension Extend" and regeneration OFF		

Load moment limitation (LMB)	4785 psi (330 bar)
Pump performance	21.1 gpm (80 l/min)

60/427 K4 Capacity Chart

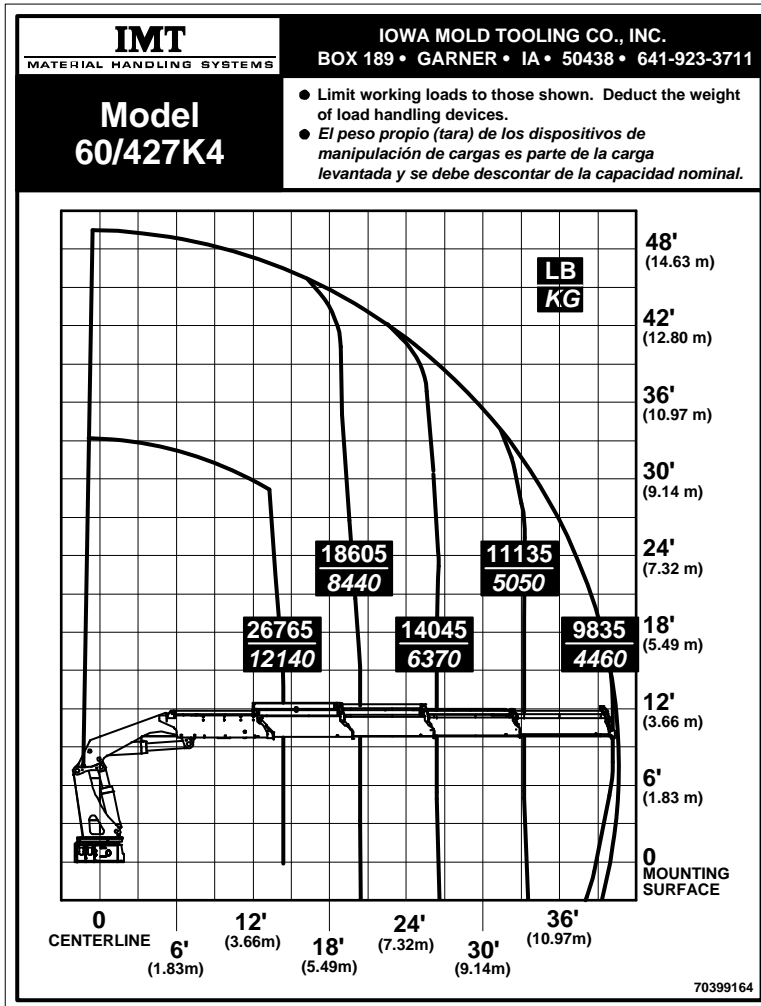

60/427 K6 Capacity Chart

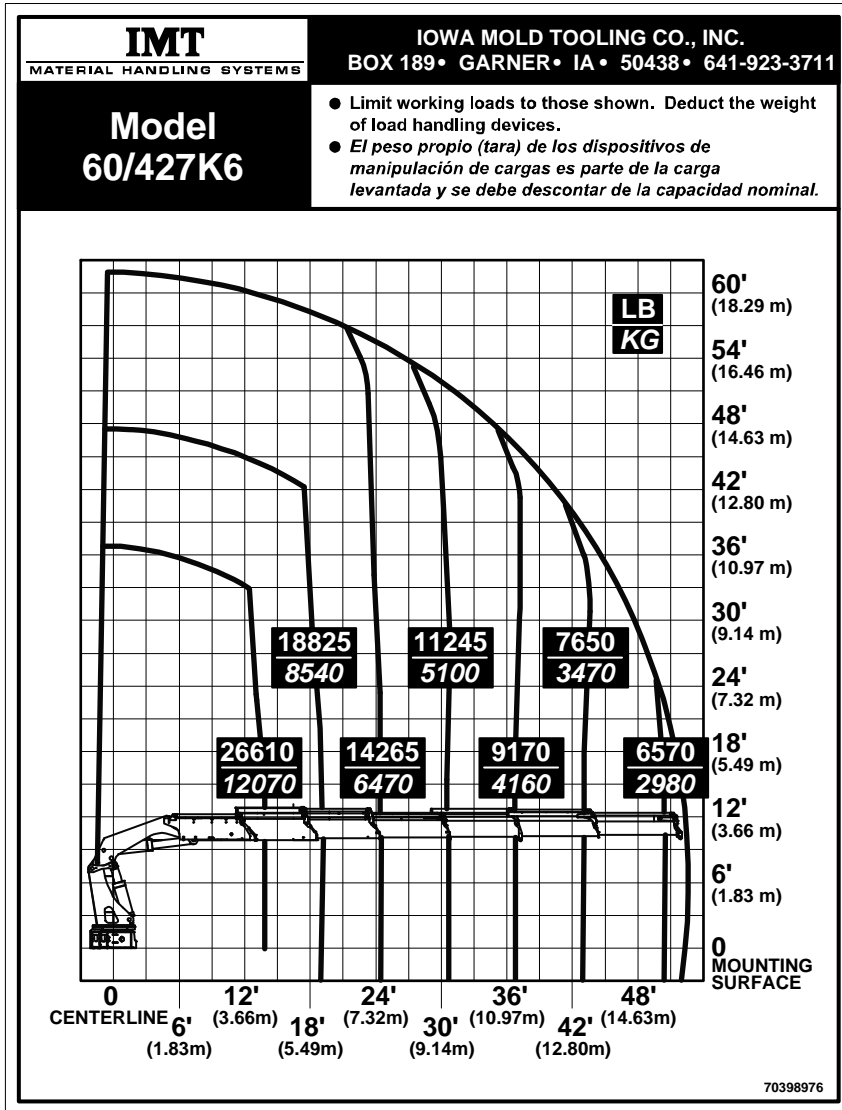

60/427 Dimensional Drawing

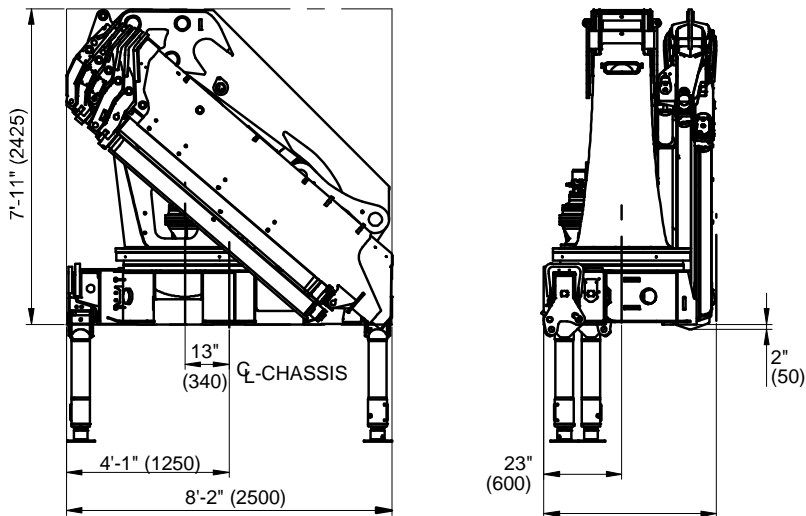
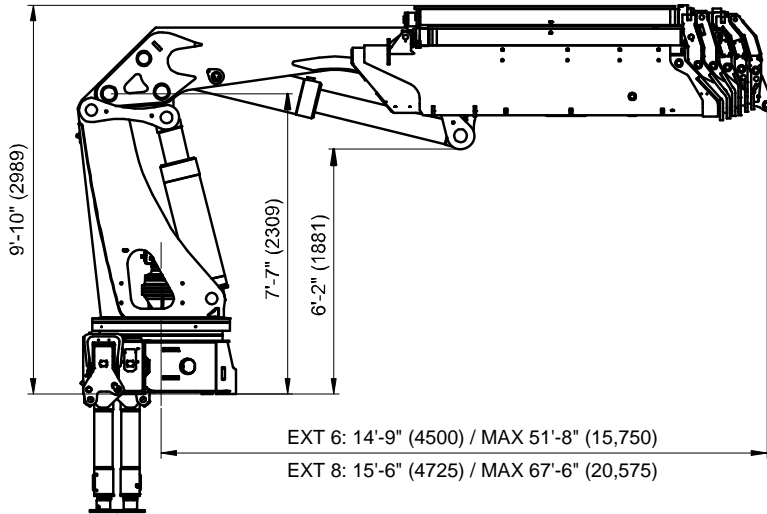

EXT 6-8: 57.5" (1460)
K6 w/FJ1200: 62.4" (1585)

NOTE:
ALL DIMENSIONS IN
FEET & INCHES (mm).

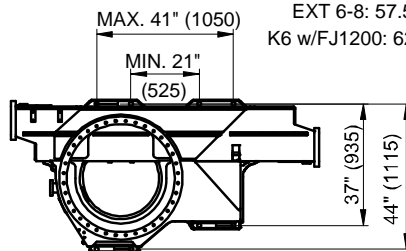

Stabilizer Dimensions, Fixed Legs, 60/427

Dimensions in feet-inches / mm

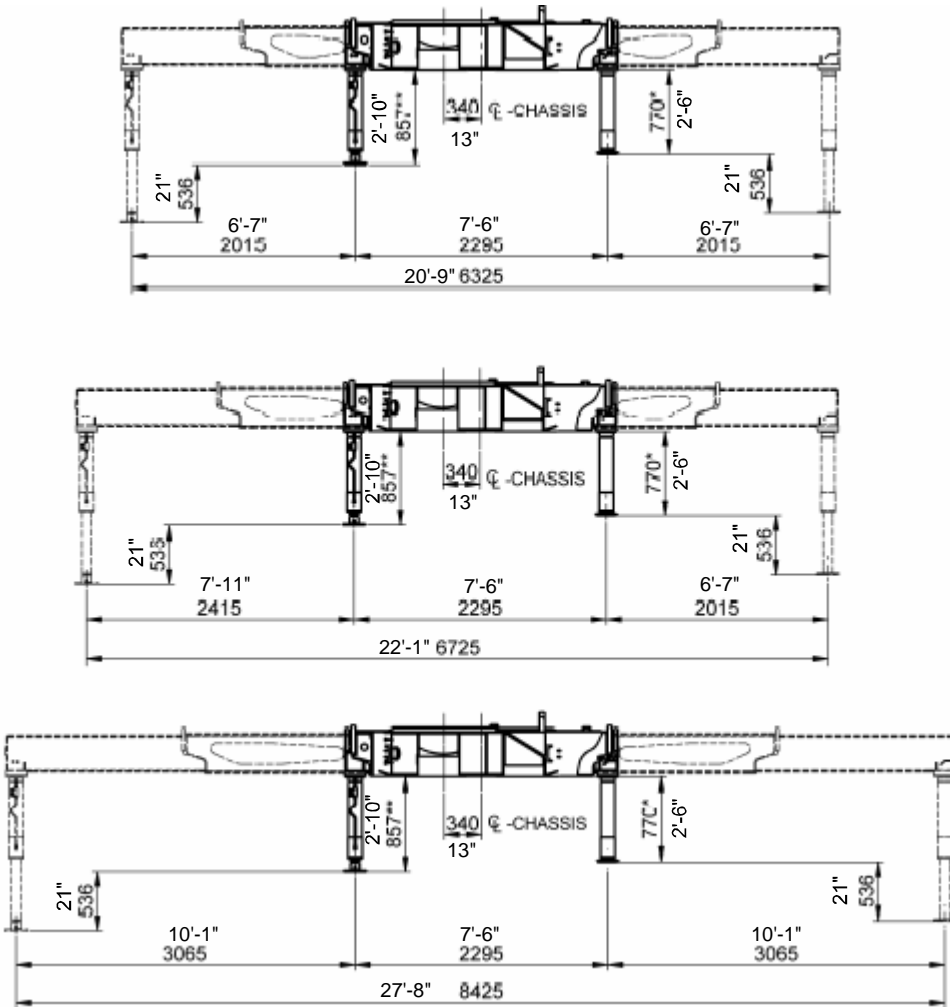

Stabilizer Dimensions, Hydraulic Swing-Up Legs, 60/427

Dimensions in feet-inches / mm.

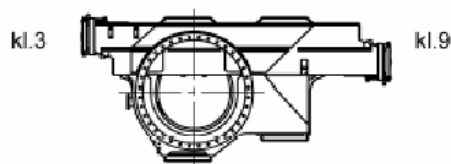
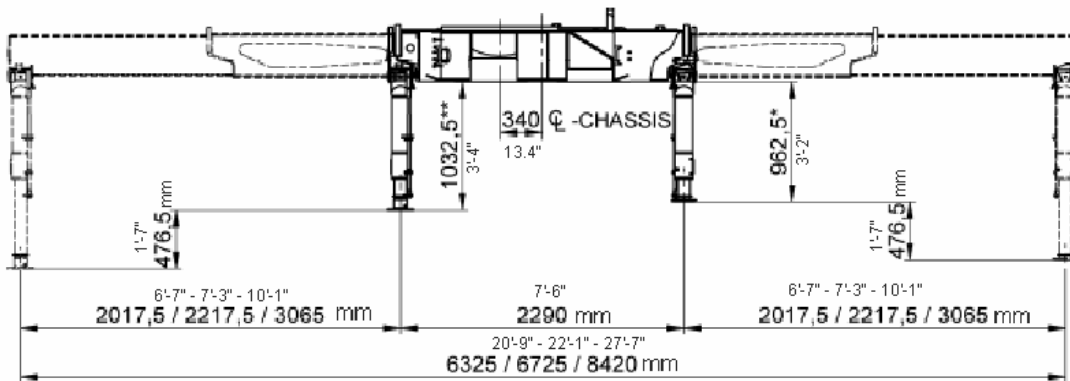
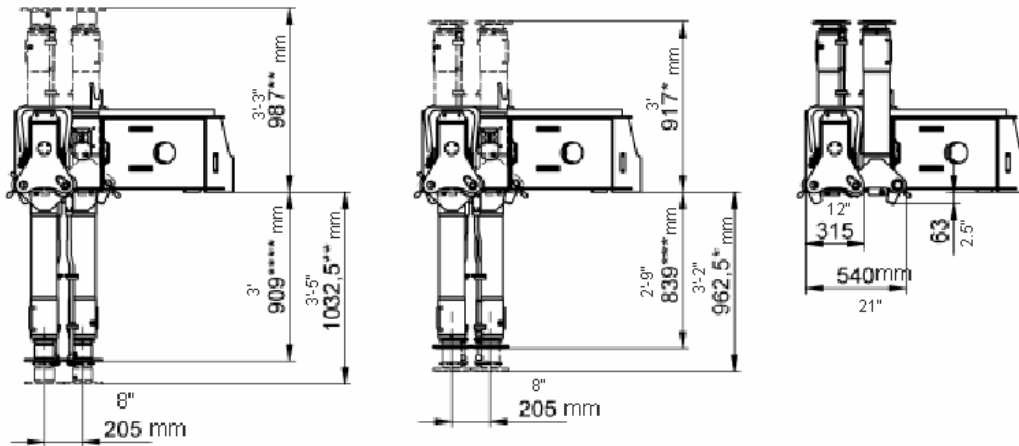

60/427 Swing Clearance

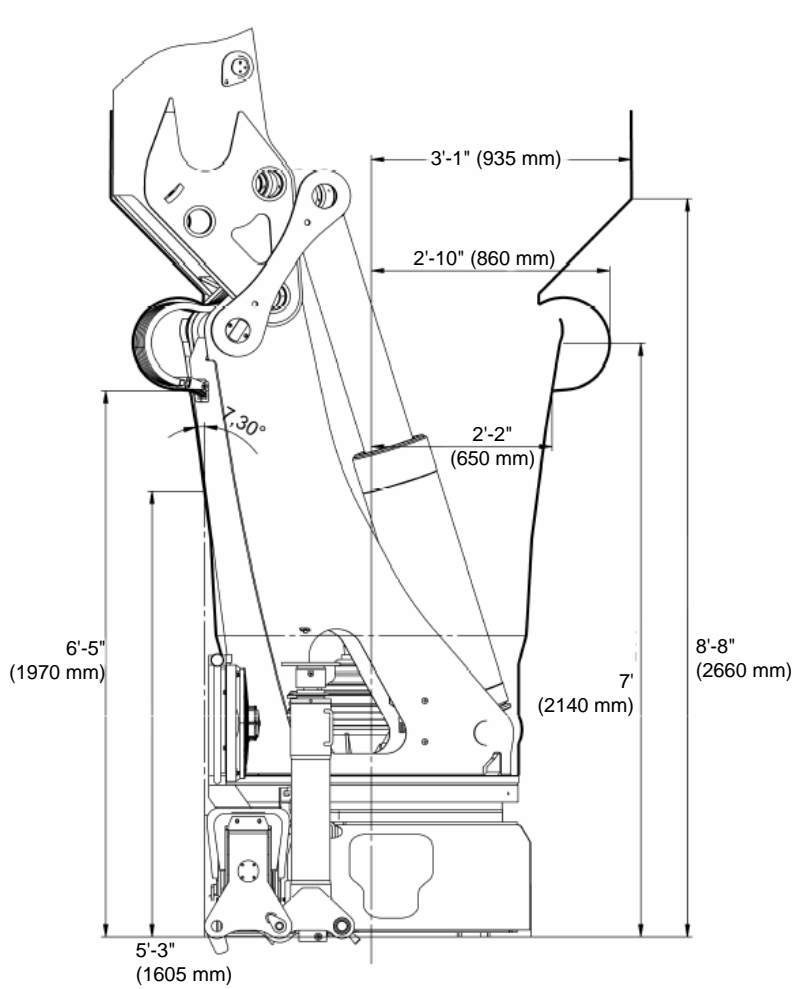

CHAPTER 2

Hydraulic Schematics

In This Chapter

60/427 Hydraulic Schematic, Single-Circuit Fixed	14
60/427 Hydraulic Schematic, Dual-Circuit Fixed	15
60/427 Hydraulic Schematic, Loader Functions.....	16

60/427 Hydraulic Schematic, Dual-Circuit Fixed

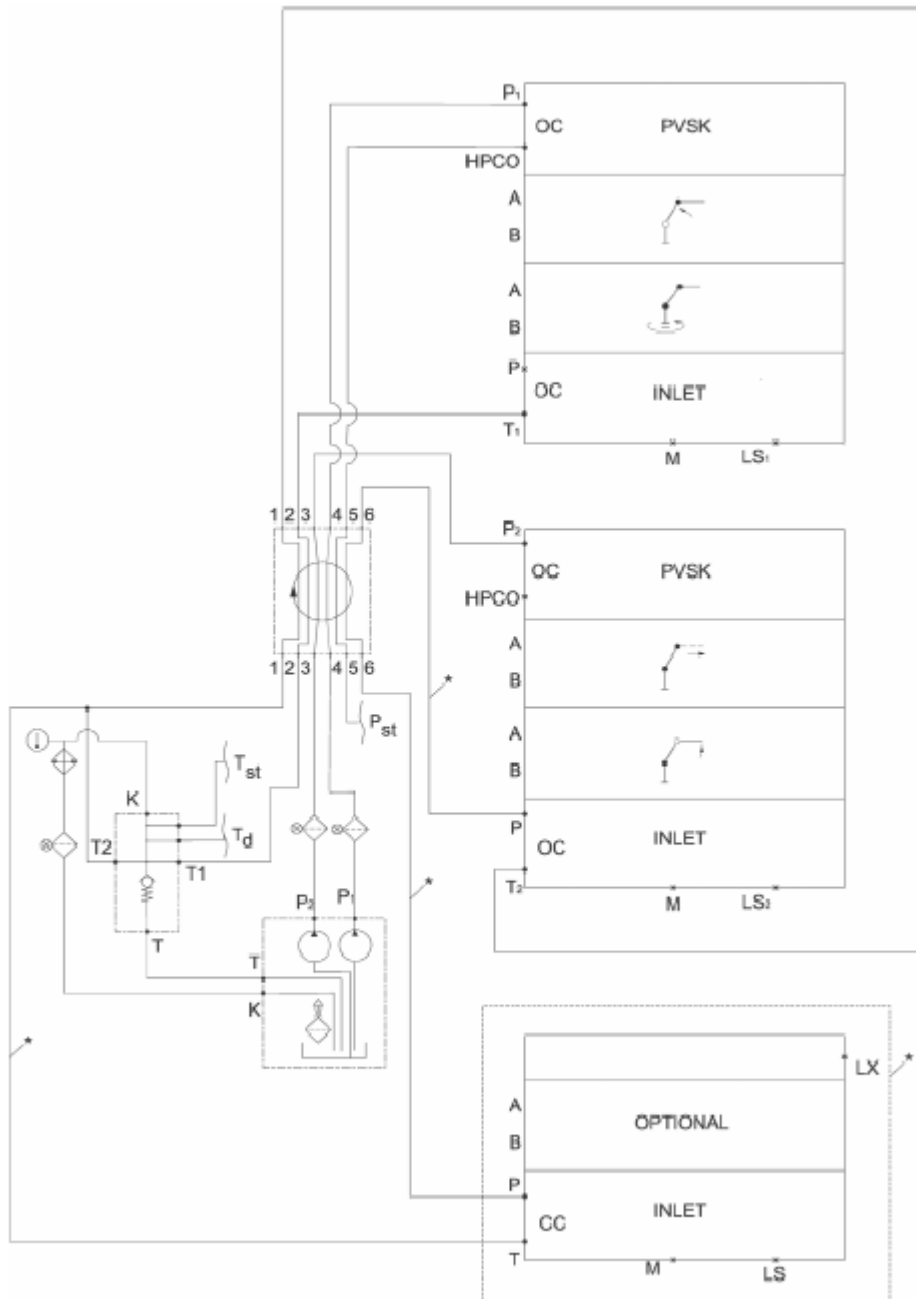

* Only in case of extra Danfoss-Function on base

60/427 Hydraulic Schematic, Loader Functions

