

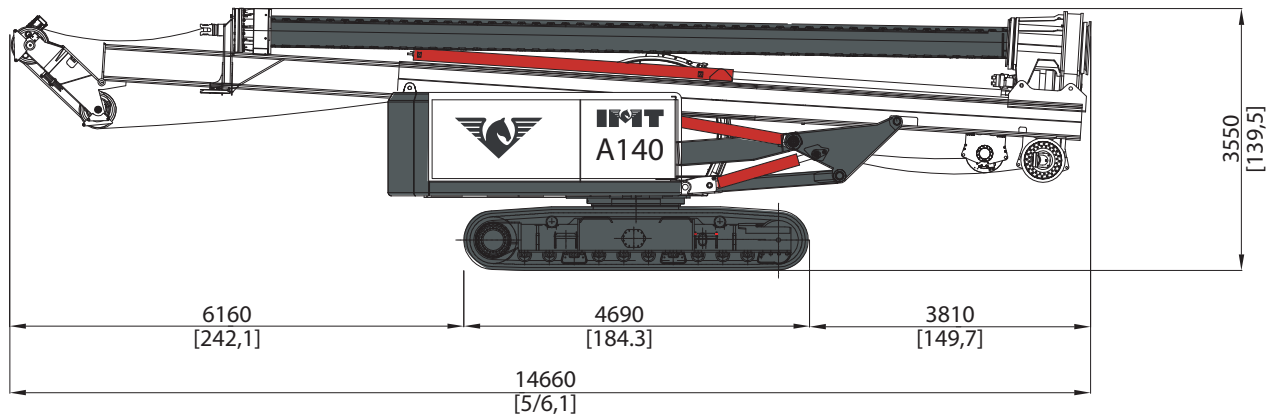

A 140



Base

| | | |
|--|----|-----------------------------|
| Undercarriage length / widening range / shoe | mm | IMT 4690/2550 - 3800/600 |
| | in | 185/100 - 149,3 / 23,6 |
| Engine type | | CUMMINS QSB 6,7 T3/T4 |
| Power | | 169Kw (227 HP) @ 1900 rpm |

Rotary

| | | |
|------------------------------|--------|----------|
| Rotary torque real / nominal | kNm | 150/173 |
| | lbf ft | 110600 |
| Working speed | rpm | 7,5 - 25 |
| Discharge speed | rpm | 45-112 |

Winches

| | | |
|--------------------------------|--------|-------|
| Main winch pull force | kN | 145 |
| | lbf | 32600 |
| Main winch speed | m/min | 90 |
| | ft/min | 295 |
| Main winch Cable diameter | mm | 22 |
| | in | / |
| Auxiliary winch pull force | kN | 80 |
| | lbf | 17985 |
| Auxiliary winch Speed | m/min | 67 |
| | ft/min | 220 |
| Auxiliary winch Cable diameter | mm | 15 |
| | in | / |

Crowd system

| | | |
|------------------|-----|-------|
| Kelly crowd push | kN | 135 |
| | lbf | 30350 |
| Kelly crowd pull | kN | 175 |
| | lbf | 39345 |
| Stroke | mm | 3700 |
| | in | 146 |

Mast

| | | |
|-----------------------|----|------|
| Mast raking forward | | 5° |
| Mast side raking | | ±5° |
| Mast raking backwards | | 15° |
| Pile max. diameter | mm | 1500 |
| | in | 60 |

Kelly bar

| | | |
|---------------------------------------|-----|--------------------|
| Standard | | 4/38 |
| Options available | | 4/34 - 5/47 - 6/57 |
| Operating Weight w/standard kelly bar | t | 37 |
| | lbs | 81580 |

Measurements in working phase

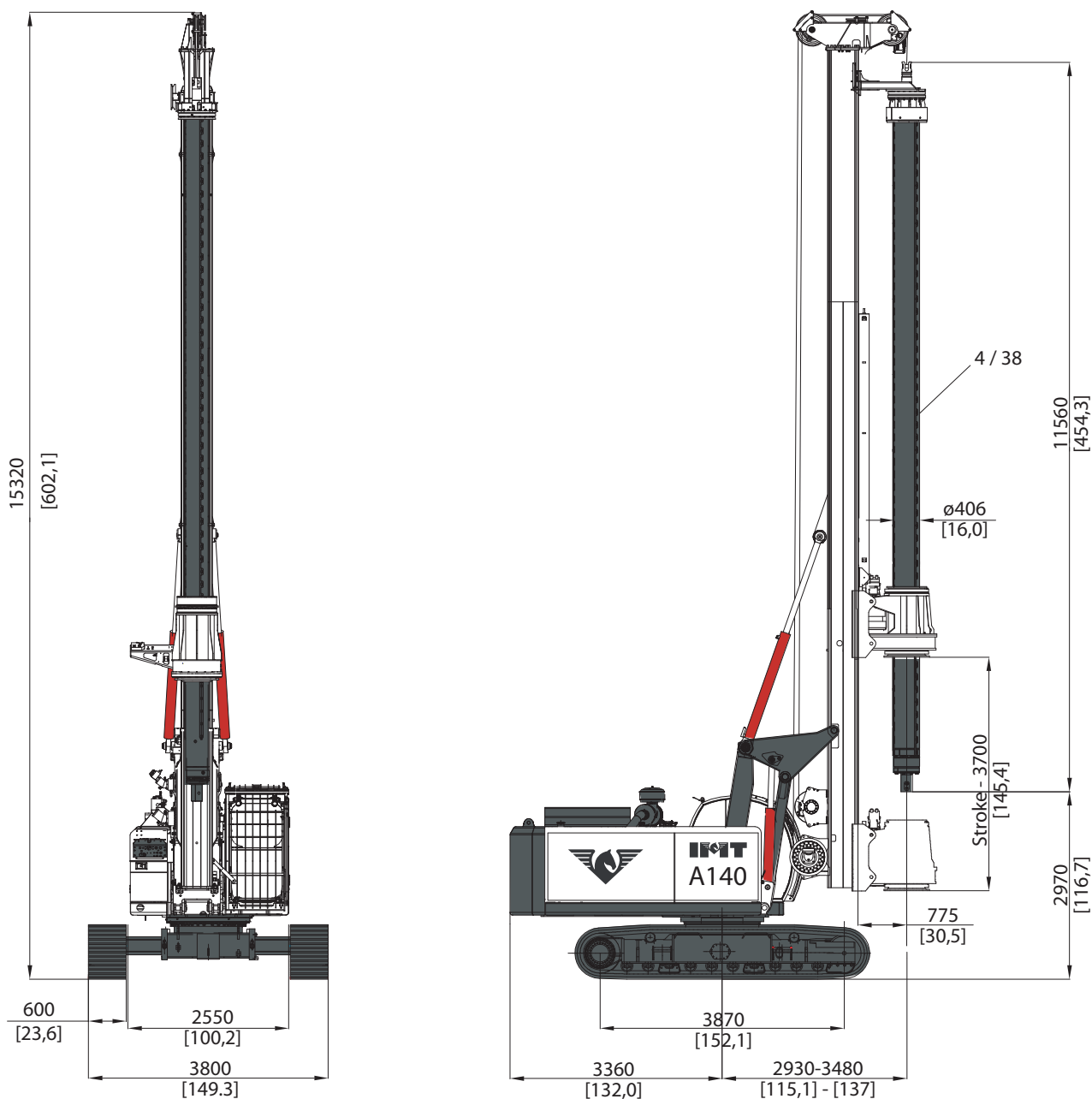

Via d'Ancona, 39 - 60027 Osimo (An) - Italy
 Tel. + 39 071 723341 r.a. - Fax + 39 071 7133352
www.imtspa.com - imt@imtspa.com

All technical data are purely indicative and subject to change without notice.