

# AF 270

## HYDRAULIC DRILL RIG



**INT**  
INTERNATIONAL®



**IMT** International S.p.A. was founded in 1974 by Mr. Giulio Accorroni. Since then, the Company has concentrated on the acquisition of specific know-how for the planning and construction of hydraulic drill rigs, in constant search of high quality products and customer satisfaction.

IMT has always invested in technology and design. This policy has given life to a new plant that is on the cutting edge and whose objective is that of raising production quality even more.

In 1999, IMT International S.p.A. was certified ISO 9001. This important, official recognition was given to IMT International S.p.A. following strict inspections carried out by authorised institutions. This confirms the quality level, which has already been appreciated over the years, all over the world.

IMT International S.p.A., like very few other companies in the field, has a global commercial and assistance network, present in over 30 countries in the world. From anywhere in the world, IMT customers know they can always count on fast and efficient 24-hours service, which ensures that all inquiries are taken care of immediately. Furthermore, all IMT models are mounted on the best known bases in the field, which gives our products reliability as well as the guarantee that spare parts can be easily found all over the world.

IMT's main goal, today, is not only to improve technology, but also to make our growing family of customers satisfied for have chosen IMT.

# AF 270



THE PERFECT BLEND  
OF TECHNOLOGY  
AND PERFORMANCE

The AF 270 is a drill rig that can easily overcome any kind of problem on the job site, even the most difficult ones.

This rig has been created for foundation piles with diameters from 450mm up to 2000mm and a depth up to 66 meters. The AF 270 is mounted on Caterpillar 349D excavator base with a Caterpillar undercarriage with extensible lower from 3m to 4,4m.

**IRIT**  
INTERNATIONAL







# OPERATOR STATION

The operator station of the AF 270 is a particular example of comfort and rationality. Besides the comfort available on the CAT base (adjustable seat, air conditioning etc) all the controls are properly placed so as to give the operator maximum control on the machine operations. The main controls, such as main winch, swing, rotary and crowd system are operated by means of two main joysticks. The drilling depth and pile verticality control systems are foreseen in the cabin.





## BASE

The AF 270 uses a CAT 349 D base. Caterpillar installs a CAT C 13-type motor on this base which is set to supply a power of 410 HP (305 KW) at 1800 rpm. In order to utilize the power of the diesel to the most so as to guarantee maximum performance, IMT installs a load sensing hydraulic system, together with the Caterpillar original for pull down (as well as for services); this translates into extremely high productivity.

## UNDERCARRIAGE

The crawler track undercarriage used on the AF 270 is the most that modern technology can offer in this category of machines.

- it has a central, "H"-type frame which can widen the lowers from 3m (for transportation) to 4,4m (working phase) and guarantees maximum operation in time and exceptional resistance to mechanical stress.
- the lowers have a length of 6m and guarantee considerable stability in any type of ground.
- it has a considerable traction force (570 KN effective) which allows easy movement even on the most difficult job sites.





## ROTARY

The rotary of the AF 270 was conceived for unlimited duration. To the side of the rotary, two transmission groups, formed by hydraulic motor and reductor gear, move the two pinions. The rotary is capable of transmitting an effective torque of 275 kNm to the tool.

The operator can change speeds from inside the cabin; there are six different speeds to choose from. The working speeds vary from 8 to 30 rpm. During the drilling phase, the rotary has the entire power of the diesel at its complete disposal. The rotation speed and effective torque on the tool are continuously recorded by the on-board computer. With the rotary it is possible to supply a universal joint for the direct installation of casings.



## MAST

It is built with high-resistance material, capable of supporting considerable stress with reduced weights (and therefore inertial force). It has great frontal (+5-15°) and lateral (+8°) range; this allows the machine to work in uneven grounds as well. The head of the mast is positioned at the top and has a "Y" shape for the pulleys of the main and secondary winches. The upper end is hydraulically articulated to change into the transportation phase. The lower extremity (articulated for transportation phase) is usually disassembled when working with casing oscillators of considerable size.

## CROWD SYSTEM

The crowd system of the AF 270 is positioned on the mast and it is used to transfer push and pull on the rotary. Thanks to the automatic blocking system patented by IMT, the push of 300 KN and pull of 390 KN are transferred directly to the tool.







## KELLY BAR

The standard Kelly bar is 4/46 (depth of 46 meters). The 4/48, 5/66, 4/35 and other types are also available. The square joint is available with sides of 150, 177, 200mm. All Kelly bars have automatic blocking patented by IMT; this allows the blocking of the telescopic elements in any position, permitting the transfer of pull down, pullback and torque very quickly.









# WINCHES

The main winch is positioned in the lower part of the mast, in front of the cabin so that the operator can constantly check the proper operation. During the lifting and lowering phase, the winch has the entire power of the diesel at its disposal; this gives the machine considerable speed and therefore maximum productivity. It has a hydraulic "down the hole" system which prevents the unwinding of the cable when the tool reaches the ground. Another system, called "free flow", allows the cable to advance in the drilling phase when the rotary advances. The depth of the tool is constantly recorded by the on board computer. The main winch has a maximum pull back of 250 KN and a speed of 73 m/min. As far as the secondary winch is concerned, the maximum speed is 85 m/min with a pullback of 120 KN.

9

# ARTICULATION

The AF 270 utilizes a parallelogram type articulation. All the articulations of the machines use casehardened pins and bushings of large dimensions which guarantee maximum precision in time. The parallelogram type articulation offers the following advantages:

- possibility of moving the working axis accurately without losing the verticality of the mast
- possibility of working in a large range (essential when working with casing oscillator)
- correct anchoring of the mat by means of a hinge and tilting cylinder anchored at the top
- correct distribution of the machine weight in transportation configuration

**IRIT**  
INTERNATIONAL

# AF 270

TECHNICAL DATA

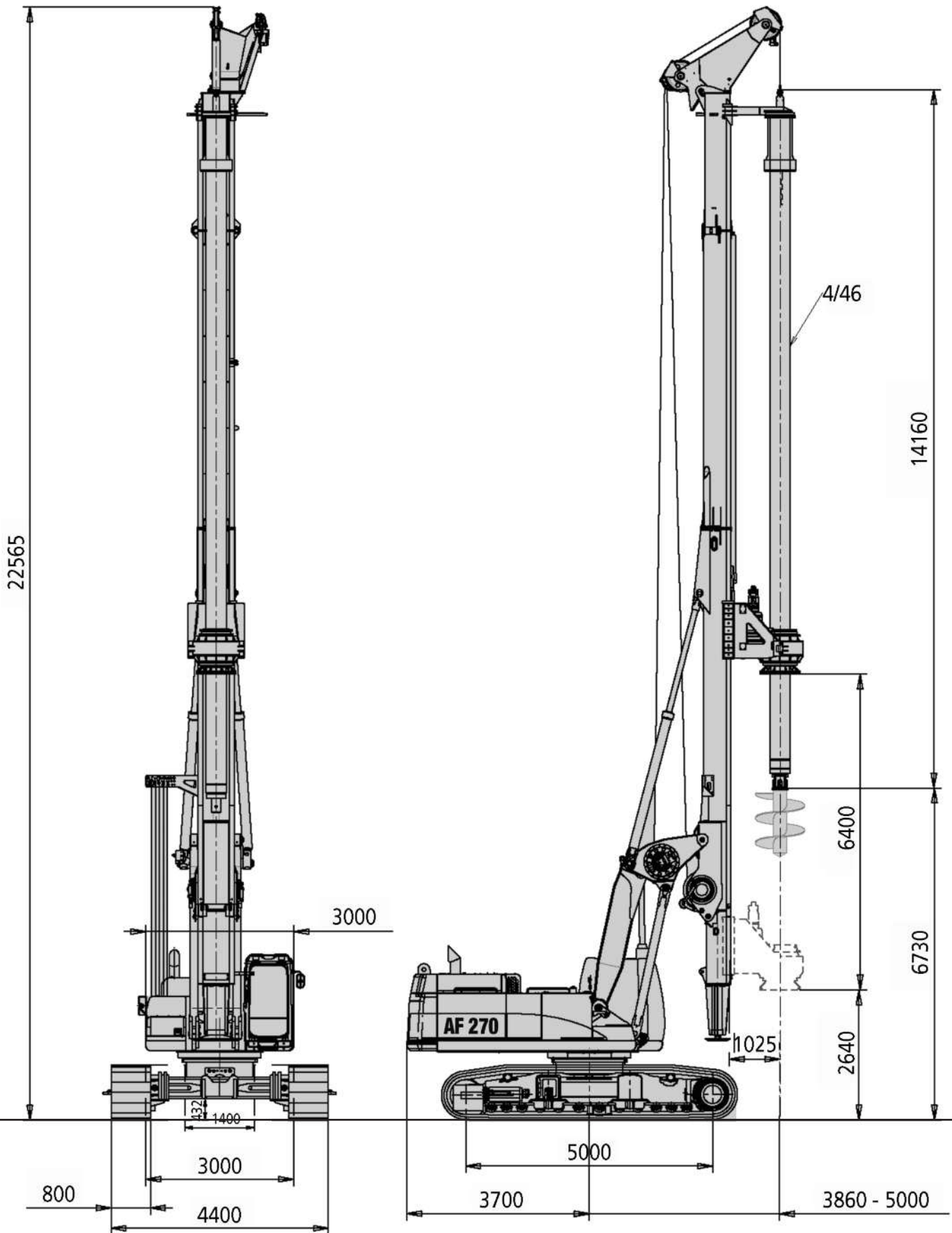



|  |           |                            |        |                           |
|--|-----------|----------------------------|--------|---------------------------|
| <b>Base</b>                                  |           | CAT 349 D                  |        | CAT 349 D                 |
| Undercarriage length / widening range / shoe | mm        | 6000/3000 - 4400/800       | in     | 236/118 - 173/31,5        |
| Engine type                                  |           | CAT C13                    |        | CAT C13                   |
| Power  |           | 305 Kw (410hp) @ 1800 rpm. |        | 305 Kw (410hp) @1800 rpm. |
| <b>Rotary</b>                                |           |                            |        |                           |
| Installed torque                             | kNm       | 275                        | lbf ft | 202830                    |
| Working speed                                | rpm       | 8 - 30                     | rpm    | 8 - 30                    |
| Discharge speed                              | rpm       | 48 - 115                   | rpm    | 48 - 115                  |
| <b>Winches</b>                               |           |                            |        |                           |
| Main winch pull force                        | kN        | 250                        | lbf    | 56200                     |
| Main winch speed                             | m/min     | 73                         | ft/min | 240                       |
| Main winch Cable diameter                    | mm        | 28                         | in     | /                         |
| Auxiliary winch pull force                   | kN        | 120                        | lbf    | 26980                     |
| Auxiliary winch Speed diameter               | m/min     | 80                         | ft/min | 262                       |
| Auxiliary winch Cable diameter               | mm        | 22                         | in     | /                         |
| <b>Crowd system</b>                          |           |                            |        |                           |
| Kelly crowd push                             | kN        | 300                        | lbf    | 67445                     |
| Kelly crowd pull                             | kN        | 390                        | lbf    | 87680                     |
| Stroke                                       | mm        | 6400                       | in     | 252                       |
| <b>Mast</b>                                  |           |                            |        |                           |
| Mast raking forward                          |           | 5°                         |        | 5°                        |
| Mast side raking                             |           | ±8°                        |        | ±8°                       |
| Mast raking backwards                        |           | 15°                        |        | 15°                       |
| Pile max. diameter                           | mm        | 2000                       | in     | 79                        |
| <b>Kelly bar</b>                             |           |                            |        |                           |
| Standard                                     |           | 4/46                       |        | 4/46                      |
| Options available                            |           | 4/35 - 4/52 - 5/50 - 5/66  |        | 4/35 - 4/52 - 5/50 - 5/66 |
| Operating Weight w/standard kelly bar        | t(metric) | 80                         | lbs    | 176370                    |

All technical data are indicatives and subject to change without notice

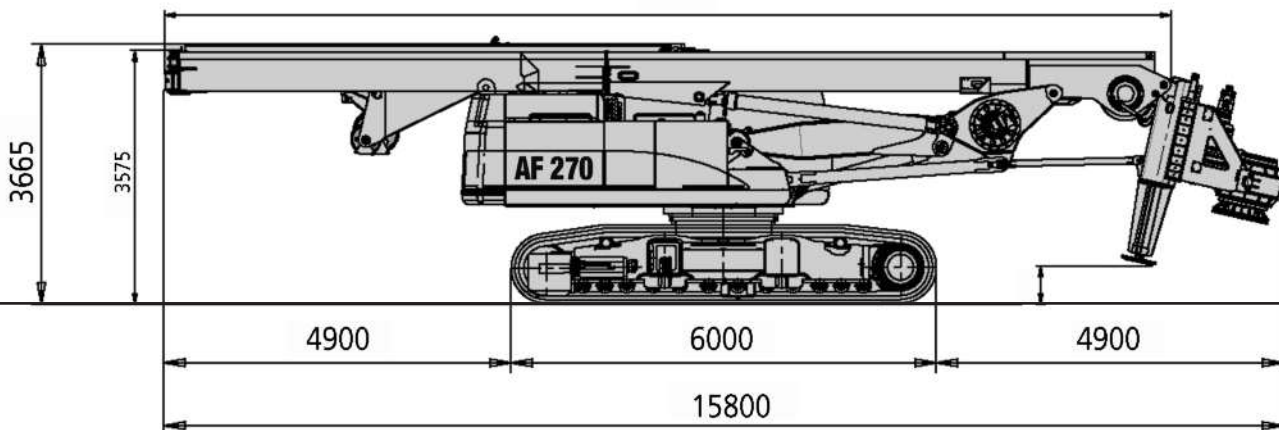

# WORLDWIDE SALES AND ASSISTANCE NETWORK



## **IMT dealers, a global network at your service**

IMT, like very few other companies in the field, has a global commercial and assistance network which is present in over 30 countries. From any part of the world, IMT clients know that they can always count on fast and efficient service.







**I.M.T. INTERNATIONAL S.p.A.**

**Industria Meccanica Trivelle**

via D'Ancona, 39

60027 Osimo (AN) Italy

Tel. +39 071 723 341

Fax +39 0717 133 352

imt@imtspa.com

www.imtspa.com

