

# **INTERSTATE**



## **16BST**

**THE  
DEFINITION  
OF VALUE**

**CONTINUOUS MAIN  
BEAM DESIGN**

**HEAVY DUTY SPRING  
SUSPENSION**

**HEAVY DUTY ELECTRIC  
BRAKES**

**DISC TYPE WHEELS**

**215/75R17.5, (H)  
TIRES**



TRAILERS, INC. 1101 HERITAGE PARKWAY MANSFIELD, TEXAS 76063  
 Visit our Web site at [www.interstatetrailers.com](http://www.interstatetrailers.com)

**817/453-5402**  
**800/433-5384**  
**Fax: 817/453-5445**

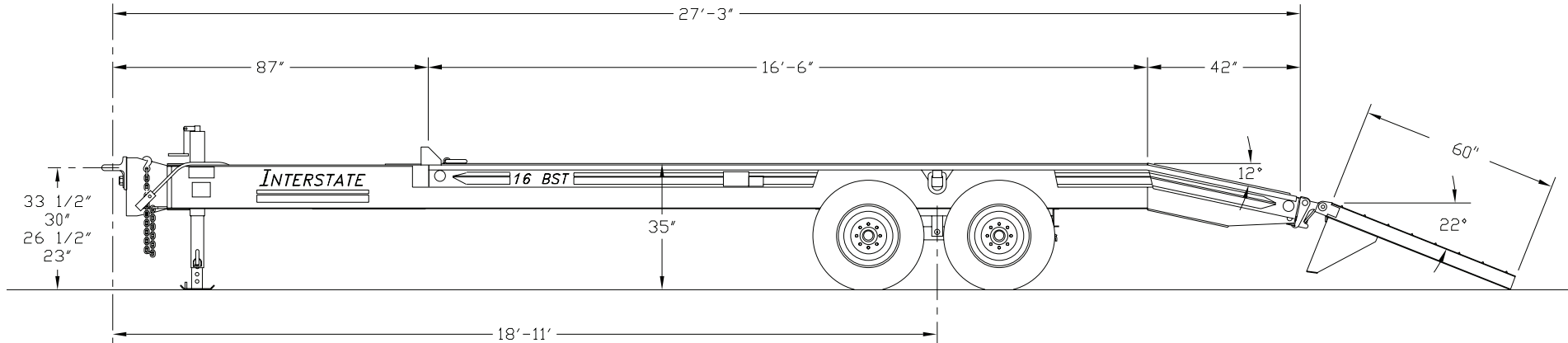

## MODEL 16BST

CAPACITY:	16,000# @ 55 MPH	Main Rails:	W12" x 16" A572 Gr 50 - High Tensile
Trailer Weight:	4750#	Crossmembers:	6" Jr. I Beam - High Tensile
Overall Length:	27' 3"	Heavy Duty Axles:	(2) 8,000#
Overall Width:	96"/102"	Heavy Duty Brakes:	Electric 12 1/4" x 3 3/8"
Platform Length:	20' 0"	Jack:	10,000# Top Crank
Platform Height:	35"	Heavy Duty Suspension:	Spring Type
Dovetail Length:	42"	Tires:	(4) 215/75R x 17.5 - 16 Ply Radial
Ramp Length:	60"	Heavy Duty Wheels:	(4) 6.00 x 17.5 - 8 Hole Disc
Ramp Width:	21 1/2"	Lights & Electric:	LED Sealed Beam System/ICC & DOT Approved
Decking:	2" Nominal Hardwood	Hitch:	Adjustable Pintle Eye - 4 Position

Break-A-Way Switch System with Gel Cell Battery

Your **INTERSTATE** Dealer Is

Interstate Trailers, Inc. reserves the right to change design, material and/or specifications without notice and without incurring any obligation to such changes.