

# **INTERSTATE**



## **24DT**

**THE  
DEFINITION  
OF VALUE**

**CONTINUOUS  
MAIN BEAM WITH  
INTERLOCKING  
CROSSMEMBERS**

**EXCLUSIVE HEAVY  
DUTY ADJUSTABLE  
SPRING SUSPENSION**

**HEAVY DUTY  
ELECTRIC BRAKES**

**DUAL WHEELS &  
TANDEM AXLES**

**SPRING ASSISTED  
RAMPS**

**DISC TYPE WHEELS**

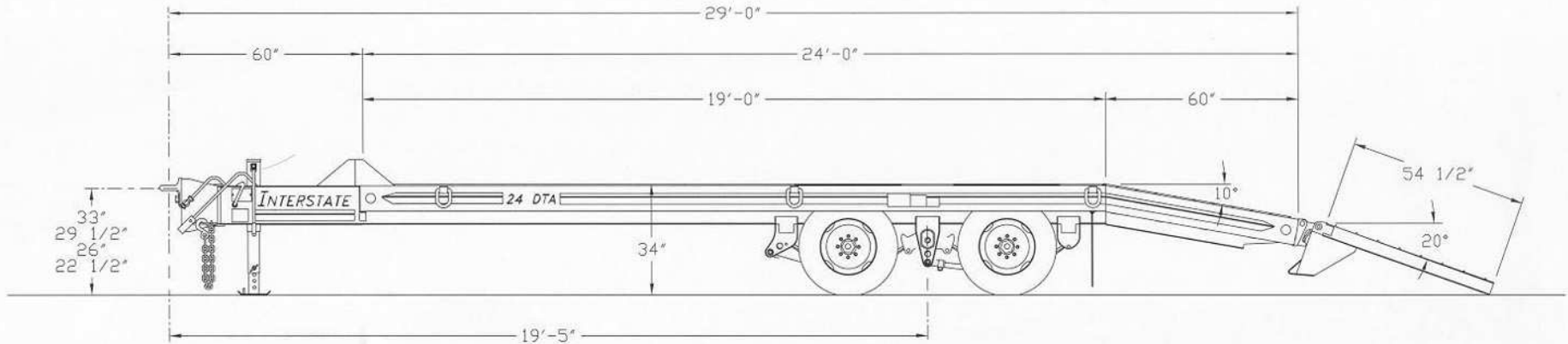

## Model 24DT

CAPACITY: 24,000# @ 65 MPH  
 Overall Weight: 6250#  
 Overall Length: 29' 0"  
 Overall Width: 96"/102"  
 Platform Length: 24' 0"  
 Platform Height: 34"  
 Dovetail Length: 60"  
 Ramp Length: 54 1/2"  
 Ramp Width: 21 1/2"  
 Decking: 2" Nominal Hardwood

Main Rails: W12" x 16# A572 Gr. 50 High Tensile  
 Crossmembers: 6" Jr. I Beam A572 Gr. 50 High Tensile  
 Heavy Duty Axles: (2) "Dexter" 12,000#  
 Heavy Duty Brakes: Electric. 12-1/4" x 5"  
 Heavy Duty Suspension: H9700  
 Tires: 235/80R16, (E)  
 Heavy Duty Wheels: 8 hole "Budd" Type Disc  
 Lights & Electric: Sealed Beam System/ICC & DOT Approved  
 Hitch: Adjustable Pintle Eye  
 Landing Legs: 12,000#

Your **INTERSTATE** Dealer Is