

INTERSTATE



40TDL

**THE
DEFINITION
OF VALUE**

**TAPERED REAR END
WITH RECESSED
LIGHTS**

**LED LIGHTS & SEALED
MODULAR WIRING**

**HEAVY DUTY SPRING
SUSPENSION**

**(2) HEAVY DUTY
CUSHION CYLINDERS**

**8 HOLE, HUB PILOTED
STEEL DISC WHEELS**

**STRAIGHT-THRU
CHASSIS DESIGN**

UNDERCOATED



TRAILERS, INC. 1101 HERITAGE PARKWAY MANSFIELD, TEXAS 76063
 Visit our Web site at www.interstatetrailers.com

817/453-5402
 800/433-5384
 Fax: 817/453-5445

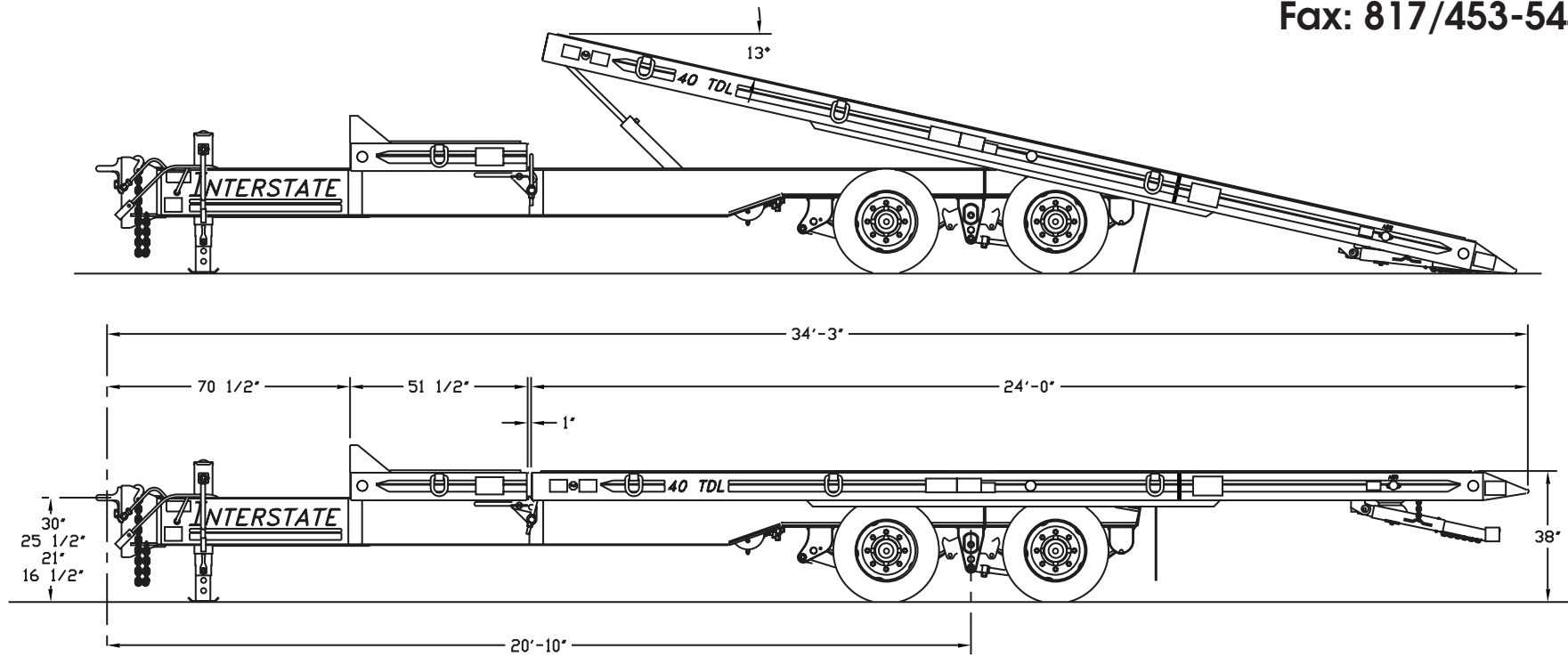

MODEL 40TDL

CAPACITY:	40,000# @ 55 MPH	Crossmembers:	Tilt Bed – S6" x 12.5# A572 Gr.50 High Tensile
Trailer Weight:	10,000#	Chassis:	4" x 4" Rectangular Tube A500B
Overall Length:	34' 3"	Heavy Duty Axles:	(2) 22,500#
Overall Width:	102"	Heavy Duty Brakes:	12 1/4" x 7 1/2" Air - ABS Spring Parking Brakes on both Axles
Tilt Deck Length:	24' 0"	Heavy Duty Suspension:	Hutch 9700
Stationary Deck:	51 1/2"	Tires:	(8) 215/75R x 17.5 - 16Ply Radials
Platform Height:	38"	Heavy Duty Wheels:	8 Hole, Hub Piloted Steel Disc
Decking:	2" Nominal Hardwood	Lights & Electric:	LED Lights and Sealed, Modular Wiring Harness, ICC & DOT Approved
Hitch:	Adjustable Pintle Eye	Heavy Duty Jack:	25,000# Two Speed Jack
Main Rails:	Tilt Bed W-8" x 15# A572 Gr 50 High Tensile		
Chassis:	W14" x 26# A572 Gr 50 High Tensile		

Your **INTERSTATE** Dealer Is

Interstate Trailers, Inc. reserves the right to change design, material and/or specifications without notice and without incurring any obligation to such changes.