



Product Catalog

SPK60

# The Company



**Jekko is a world leading manufacturer of minicranes with more than 45 years of experience in the lifting and handling sector.** The company is headquartered in the province of **Treviso**, occupying a **17,000 sq. m.** industrial estate – 7,000 of which are indoors. The entire range of **Jekko minicranes is exported and traded all over the world by a network of more than 30 authorised dealers.** Our products are engineered to meet our customers' specific requirements and are designed to **operate in narrow places where space is restricted.** Depending on the model, their **compact size** allows passage through a standard or double doorway. But their modest weight and slim dimensions come with no compromise to **lifting capacity or working range**, resulting in substantial

operational benefits both indoors and outdoors. Jekko offers a complete line of **models equipped with diesel engine, electric motor or battery pack** and a wide range of **attachments including hook or hydraulic jibs, grabber manipulators for pipes and beams, vacuum lifters for glass panes as well as lifting beams.** All tools are fully integrated with the functions and safety devices of the base machine. Jekko has always invested in **R&D**, safety and compliance with all relevant regulations – in particular with the **EN 13000** standard – to **offer its customers innovative and safe products.** Jekko is a young business, supported by a professional technical department, reliable training and **after-sales services**, and a sales & marketing office covering all international markets.



## PRODUCTS

Jekko minicranes are safe and technologically advanced; payback on a minicrane is immediate in the case of a sale and achieved in the short term in the case of rental.



## WORK TEAM

Jekko consists of a young and highly-qualified team whose innovative mindset and enthusiasm for continuing professional development are one of the company's flagship assets.



## MADE IN ITALY

From design to assembly, as well as components and suppliers, all our products are 100% Made in Italy.



## INTERNATIONAL NETWORK

Jekko is present in the five continents through its network of more than 30 authorised dealers.



## AFTER-SALES SERVICE

Jekko's prompt and reliable after-sales operation offers an online service for spares and warranty management and a training department for technical courses.



## INNOVATION

Jekko products take innovation to the limit, with exhaustive research and engineering and a thorough understanding of market needs.





## MINICRANES

Six different telescopic mini crawler crane models with outriggers – designed for easy transport and ultimate versatility. These machines can work in all kinds of places – slopes, stairs, passageways and hard-to-reach places – and they are quick to set up.

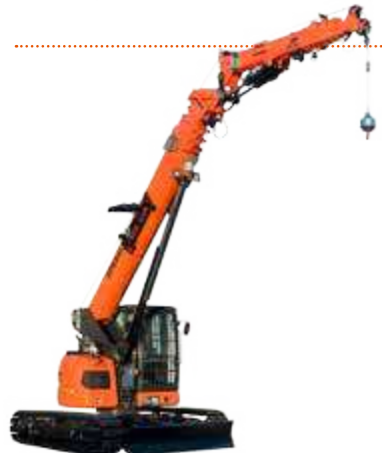

## TELE-CRAWLER CRANES

Jekko produces the only mini crawler crane on the market with an operator's cab and luffing capability thanks to its hydraulic articulated jib. It also has all the most advanced technological innovations that crane owners have come to expect: radio remote control, extendable tracks, option of diesel engine or electric motor, 3 T pick & carry capacity, hydraulic jib reaching 27.5 m and more than 50 configurations available.



## JF SERIES ARTICULATED CRAWLER CRANES

This model, combining an articulated truck-loader crane on a self-propelled crawler chasis, offers a glimpse of the future of crawler cranes.

## MINIPICKERS

Minipickers are our pick & carry self-propelled electric cranes powered by a battery and radio-remote controlled. They are well suited to working in warehouses or where access is difficult for other cranes, especially where heavy loads need to be carried through doorways. Minipickers can also be used with Jekko hydraulic manipulators or vacuum lifters for handling and positioning glazing or curtain walling.



## VACUUM & TOOLS

Lifting and handling tools for glass panes and other materials. This family of products includes hydraulic or battery-powered manipulators, vacuum lifters for glass-pane handling, grabber manipulators for pipes and beams and other specific tools.



All our cranes are designed to operate in narrow places where space is restricted. Our ongoing R&D activity has brought these machines into many sectors of industry.

# Sectors of application



## Glass pane handling

Installation of glazing and curtain walling on buildings and skyscrapers, handling glass panes and non-porous materials using hydraulic manipulators and vacuum lifters integrated with our cranes.



## Constructions & Building

All kinds of building work, from housing to civil engineering.



## Mining, oil, nuclear, chemical, drilling and military sectors

These specific fields demand the highest standards in terms of accuracy, light-weight tools and handiness: that's exactly what Jekko minicranes offer.



## Industrial maintenance

Indoor and outdoor industrial maintenance: shopping malls, ships, museums, schools, hospitals, exhibition halls as well airports, sports grounds, roads, leisure parks, graveyards, houses, railways, etc...



## ... and others

With its entrepreneurial flair, Jekko has introduced the mini crane concept to all kinds of niche applications, including cinema, advertising, product promotion, airspace, luxury, etc...

# Our Strengths



3°  
1,5°  
0,7°  
0°



1

## 4 SIDE INCLINATION MODES:

- ✓ 0°
- ✓ 0,7°
- ✓ 1,5°
- ✓ 3°



## AUTOMATIC/SUGGESTED SELECTION



2



## EXTENDABLE TRACKS

4



## COMFORTABLE PROPORTIONAL JOYSTICK WITH ALL CONTROLS ON THE THUMB

5

## DIESEL ENGINE 53,7 KW TIER 4

## CRANE CABIN

- ✓ FOPS certificated
- ✓ Safety glazing
- ✓ Seat with lumbar support
- ✓ Air condition
- ✓ Radio FM
- ✓ Safety belt
- ✓ Panoramic roof

3



# Our Strengths



## LMI LOAD MOMENT INDICATOR

- ✓ Displays all the information on the boom or any attachment position
- ✓ Displays weight of the load being lifted and the maximum safe working load capacity
- ✓ Prevents overloading and tipping by cutting out when safe limits are approached
- ✓ More than 60 configurations and load charts available



## OTHER FUNCTIONS

- ✓ Crane Carrier Interlock (CCI)
- ✓ Anti Two Block (A2B)
- ✓ Virtual Walls (VW)
- ✓ Two speed tracks (2ST)
- ✓ Plug & Play Attachment (PPA)



## DIAGNOSTIC TROUBLE CODE (DTC)



## REMOVABLE COUNTERWEIGHT



## EASY TRANSPORT



Rear Camera

## WINCH

- ✓ Hydraulic Winch 1.500kg, 125-metre rope length
- ✓ Double Speed Winch (2SW)
- ✓ Automatic camera switch while using winch

## 3 T PICK&CARRY 360°

## 4 BOOM EXTENSIONS:

- ✓ 2 by hydraulic cylinders
- ✓ 2 by chains

max

6 T MAXIMUM CAPACITY

## PROFESSIONAL RADIO REMOTE CONTROL

- ✓ Drives both crane and tracks
- ✓ Proportional
- ✓ Multifunctional
- ✓ LCD color Display



# Configurations & Options



**DIFFERENT ATTACHMENTS**



**ELECTRIC POWER PACK**



**HYDRAULIC EXTRA FUNCTIONS**



**VISUAL ANGLE INDICATOR (VAI)**

**RADIO REMOTE CONTROL**



**DOZER BLADE**



**STEEL OR GEOGRIP TRACKS**



**TOOL BOX**



**PERSONALIZED COLOR**



**INCLUDED IN THE STANDARD EQUIPMENT:**

- ✓ 2 T swivel overhaul ball
- ✓ LED working light
- ✓ Tower lamp
- ✓ Extendable Tracks (EXT)



SPK60



# SPK60

**max** 6000 kg

**max** 3505 x 2320 x 2640 mm

**max** 27 m

**max** 18 m

The only mini crawler crane on the market with an operator's cab and luffing capability thanks to its hydraulic articulated jib - fully featured, advanced technology and more than 50 configurations.



## Technical Information

Dimension	L x W x H	3505 x 2320 x 2640 mm
Track Ext.		3505 x 2920 mm

Crane & Options Weights		Kg
	SPK60	12200
	/	1560
	8T-D10	110
	PP400-11D.V02 PP600-11D.V03	140
	JIB1501.3HL	650
	JIB1501.FL	256
	JIB3500GX	70
	JIB300GR	245

SPK60	Diesel Engine	YANMAR 4TNV98CT-VPR	53.7 kW 73.0 Hp
-------	---------------	------------------------	--------------------

Speed		1.7/3.1 km/h
Gradability		10°

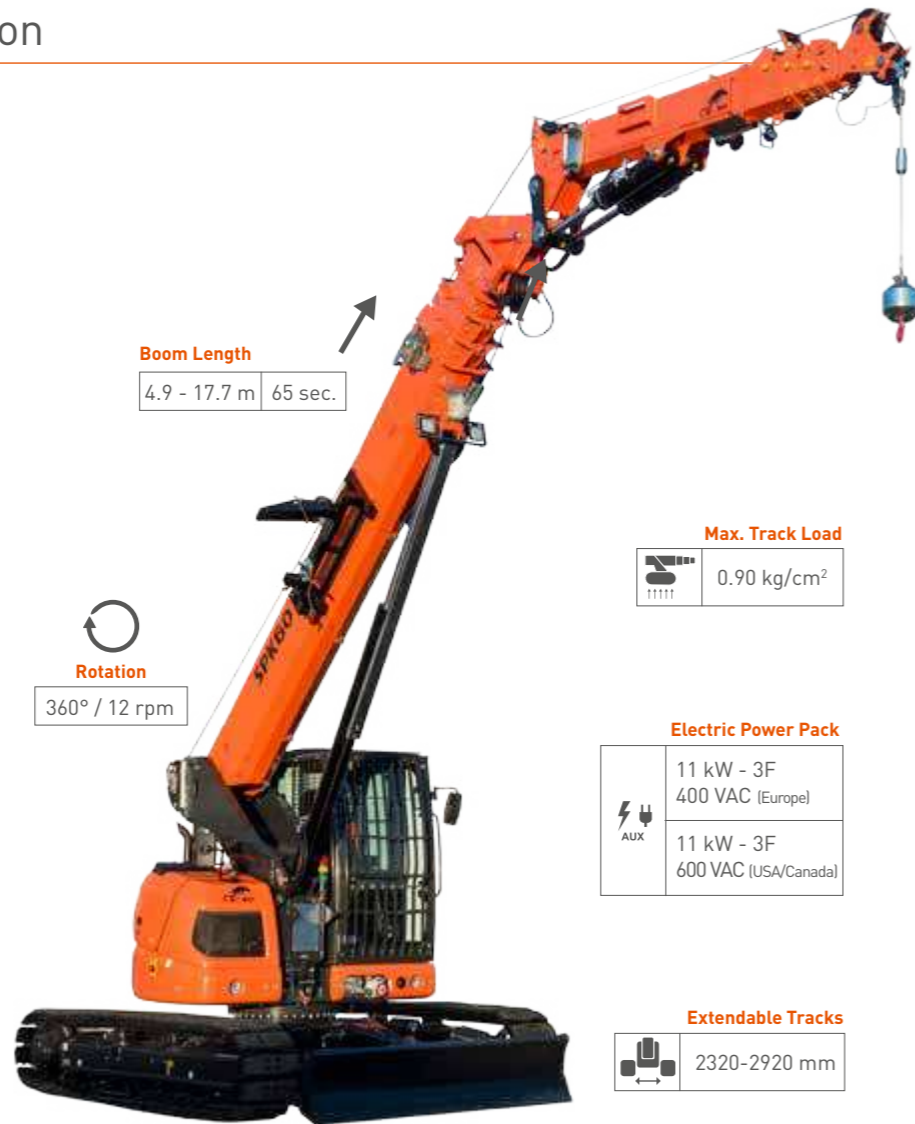

## Winch & Fall Stages

	Main Winch	1500 kg 125 m - Ø 10 mm 30-55 m/min.
--	------------	--

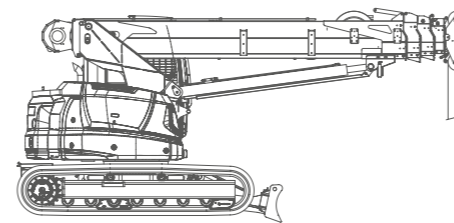

Max. Capacity	Line	Metres
6000 kg	6	-20 m
6000 kg	5	-23 m
6000 kg	4	-28 m
4500 kg	3	-38 m
3000 kg	2	-58 m
1500 kg	1	-116 m

## Load Chart

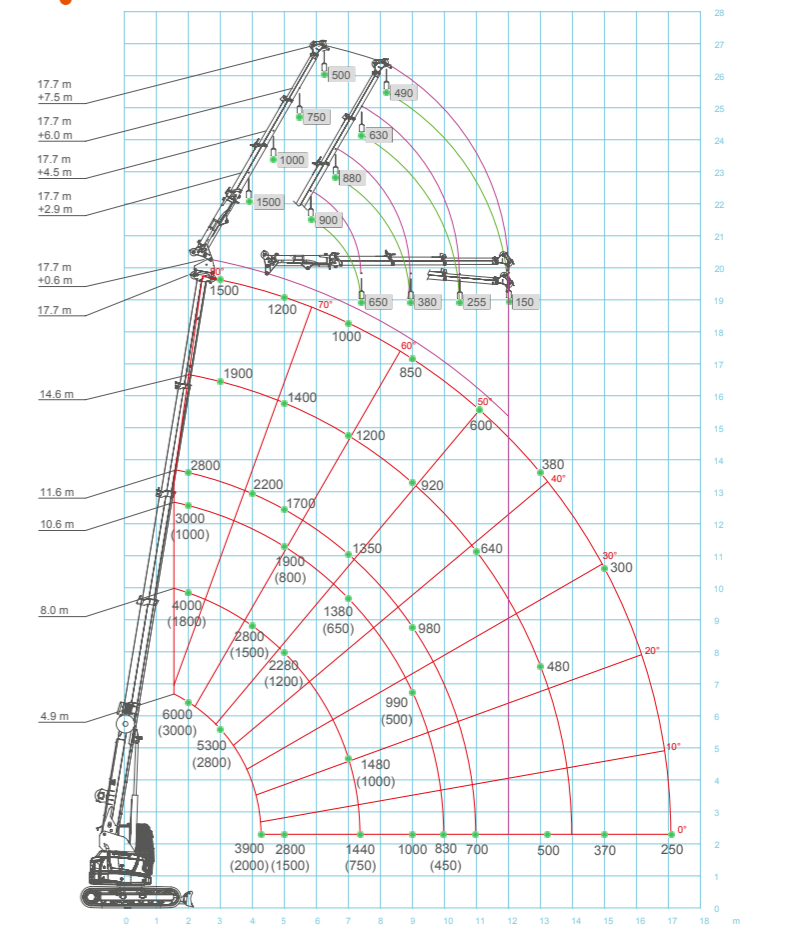

## Dimensions

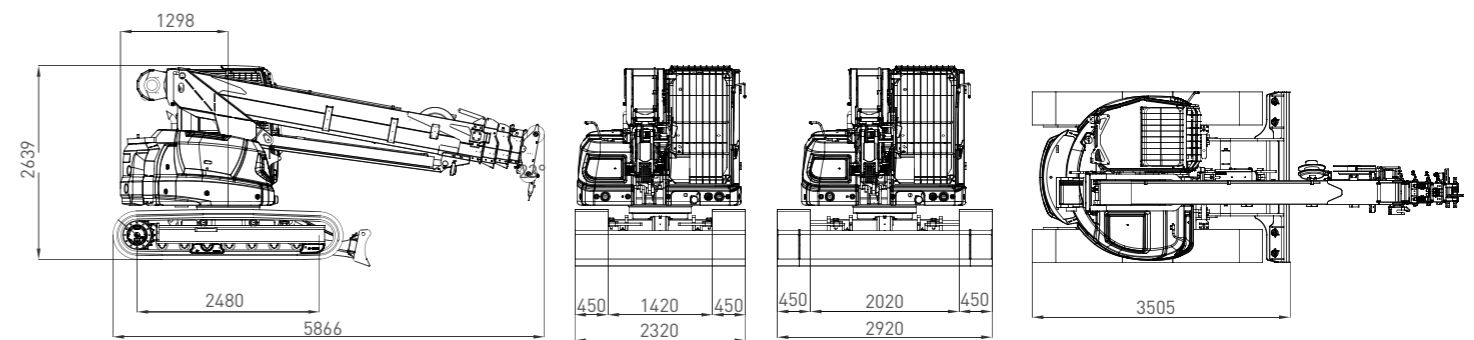

## Crane Options

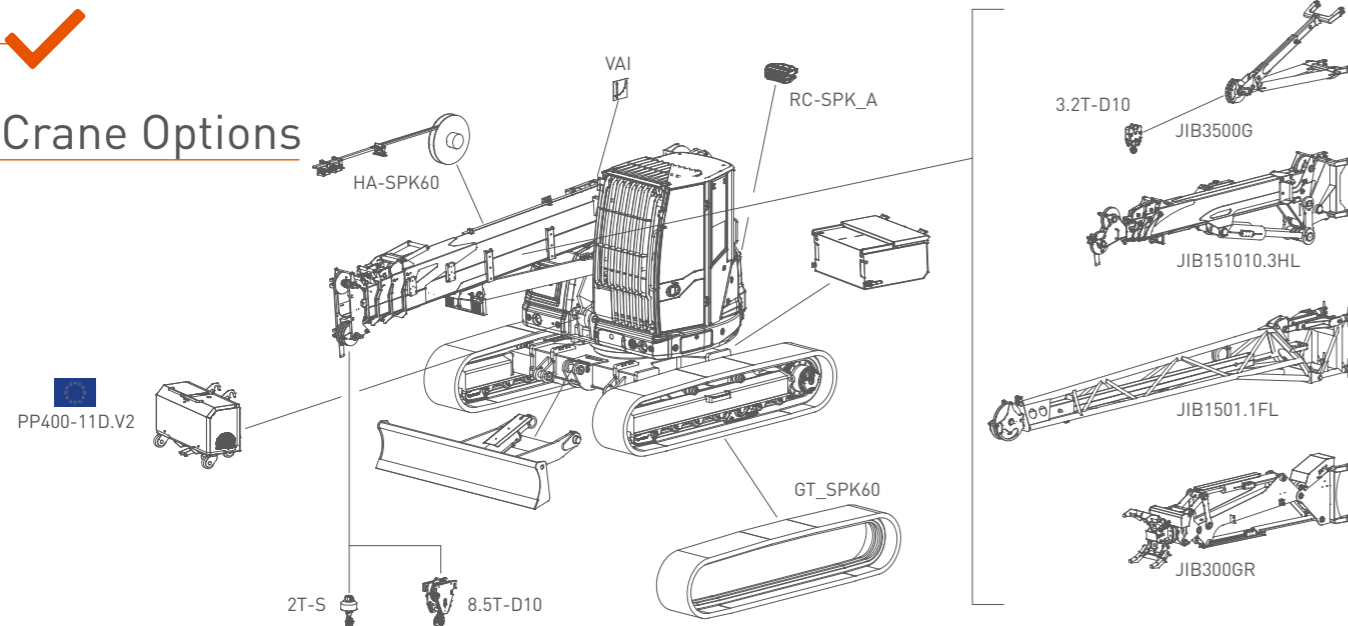

- A2B
- BPI
- CCI
- DTC
- EKT
- GSC
- LMI
- P&C
- PPA
- SCI
- TH
- VW
- RCD
- 2SW
- 2ST

## Tools Configurations

JIB3500GX	JIB1501.3HL	JIB1501.1FL	JIB300GR
3500 kg	1500 kg	1500 kg	300 kg
1330 kg @ 20.5 m	490 kg @ 26 m	700 kg @ 26 m	300 kg @ 16 m
150 kg @ 18.5 m	150 kg @ 12 m	200 kg @ 14 m	300 kg @ 11 m





## S Symbols

Extendable tracks Cingoli estensibili Ausdehbare Raupen Cingulos extensibles Chenilles extensibles	Electrical system Impianto elettrico Elektrische Anlage Sistema eléctrico Circuit électrique	Boom Slewing Rotazione braccio Auslegerdrehung Giro Rotation rallonge	Max reach Sbraccio massimo Max. Reichweite Alcance máximo Extension maximale du bras	Gradeability Pendenza superabile Steigfähigkeit Grado de inclinación Aptitude en pente	Main winch Argano principale Haupthubwerk Huinche principal Trevil principal	Tilting angle Angolo di inclinazione Auslegerverstellwinkel Angulo de inclinación Angle flèche	Slewing Rotazione Drehwerk Rotación Rotation	Liquid cooling Raffreddamento liquido Flüssigkeitskühlung Enfriamiento del líquido Refrondissement liquide
Crane Gru Kran Grua Grue	Auxiliary power pack Elettropompa ausiliaria Zusatzpumpe Electrobomba auxiliar Électropompe auxiliaire	Basket rotation Rotazione Cestello Korb-schwenkung Rotación carretilla Rotation nacelle	Max height Altezza massima Max. Höhe Altura máxima Hauteur maximale	Max outrigger load Stabilizzatori Abstützungen Estabilizadores Stabilisateurs	Jib - prolunga Auslegerverlängerung Jib prolongación Flèche	Rotation angle Angolo di rotazione Drehwinkel Angulo de rotación Angle de rotation	Building site use Utilizzo in cantiere Gebrauch auf Baustelle Utilización en el sitio Utilisation sur le site	Hookblock / Capacity Gancio / Capacità Hakenflasche / Traglast Gancho / Capacidad Crochet / Force de levage
Dimensions Dimensioni Abmessungen Dimensiones Dimensions	Man basket SWL Capacità cestello Korblast Capacidad carretilla Capacité nacelle	Number of pads Numero di ventose Anzahl der Saugteller Número de ventosas Nombre de ventouses	Opened lifting beam Bilanciere aperto Geöffnet Traverse Balancine de carga abierto Balancier ouvert	Max track loading Pressione al suolo Bodendruck Presion de apoyo Pression au sol	Engine Motore Motor Moteur	Slewing angle Angolo di rotazione Schwenkwinkel Angulo de rotación Angle de rotation	Manipulator Manipolatore Manipulator Manipulador Manipulateur	Unleaded petrol fuel Alimentazione benzina senza piombo Benzinversorgung, bleifrei Alimentación gasolina sin plomo Alimentación essence sans plomb
Weight Peso Gewicht Peso total Poids	Max working height Massima altezza di lavoro Max. Arbeitshöhe Altura máxima Hauteur max. de travail	Pad diameter Diámetro ventosa Saugtellerdurchmesser Diámetro ventosa Diamètre ventouse	Closed lifting beam Bilanciere chiuso Geschlossen Traverse Balancine de carga cerrado Balancier fermé	Maximum SWL Portata massima Max. Tragfähigkeit Carga máxima Portée max.	Rope length Lunghezza fune Seillänge Longitud de la cuerda Longueur câble	Vertical lifting Sollevamento verticale Vertikaler Hub Elevación vertical Élévation verticale	Stabilization area Area di stabilizzazione Abstützung A'area de estabilización Zone de stabilisation	
Counterweight Contrappeso Gegengewicht Contrapeso Contrepoids	Boom telescoping Lunghezza braccio Teleskopierlänge Brazo telescópico Télescopage flèche	Factory use Utilizzo in fabbrica Gebrauch in Werkhalle Utilización en la fábrica Utilisation dans l'usine	Diesel fuel Alimentazione Diesel Dieselversorgung Alimentación Diesel Alimentación Diesel	Piston Pistone Kolben Pistón Piston	Power Potenza Leistung Potencia Puissance	Horizontal lifting Sollevamento orizzontale Horizontaler Hub Elevación horizontal Élévation horizontale	Air cooling Raffreddamento ad aria Luftkühlung Enfriamiento del aire Refrondissement air	

## A Acronyms

<b>A2B</b> Anti Two Block	<b>GSC</b> Geometrical Stability Control	<b>TH</b> Tilting Head	<b>BPI</b> Boom Pressure Indicator	<b>PPA</b> Plug & Play Attachment	<b>2SW</b> Two Speed Winch	<b>DTC</b> Diagnostic Trouble Code	<b>VW</b> Virtual Wall
<b>EXT</b> Extendable Tracks	<b>SCI</b> Stability Control Indicator	<b>2ST</b> Two Speed Tracks	<b>LMI</b> Load Moment Indicator	<b>RCD</b> Radio Control Display	<b>CCI</b> Crane-Carrier Interlock	<b>P&amp;C</b> Pick & Carry	

Notes: All specifications and features herein described can be changed without prior advice. All indicated data are indicative only and are not binding as crane performs differently depending on its use.

Note: Tutte le caratteristiche e le specifiche descritte possono essere soggette a variazioni senza preavviso. Tutti i dati riportati sono forniti a puro titolo informativo e non sono impegnativi dal momento che le prestazioni della macchina variano in funzione dell'utilizzo.

Hinweise: Unangekündigte Änderungen sämtlicher Eigenschaften und Daten sind möglich. Alle Angaben sind Richtwerte und nicht verbindlich da die Leistungen der Vorrichtung von deren Einsatz abhängen.

Notas: Todas las características y las especificaciones aquí indicadas pueden ser sujetas a variaciones sin aviso. Se dan todos los datos aquí indicados como simples informaciones. No se consideran como vinculantes, dado que las prestaciones del maquinario pueden variar.

Notes: Toutes les caractéristiques et le spécifications descriptives peut être sujet à variation sans préavis. Tout les données rapportés sont fourni à titre informatif et ne sont pas engager au moment que la prestation de la machine change en fonction de l'emploi.



www.jekko.it

Visit **jekko.it** to keep in contact with us, discover all the latest news and find out technical details of all our products.

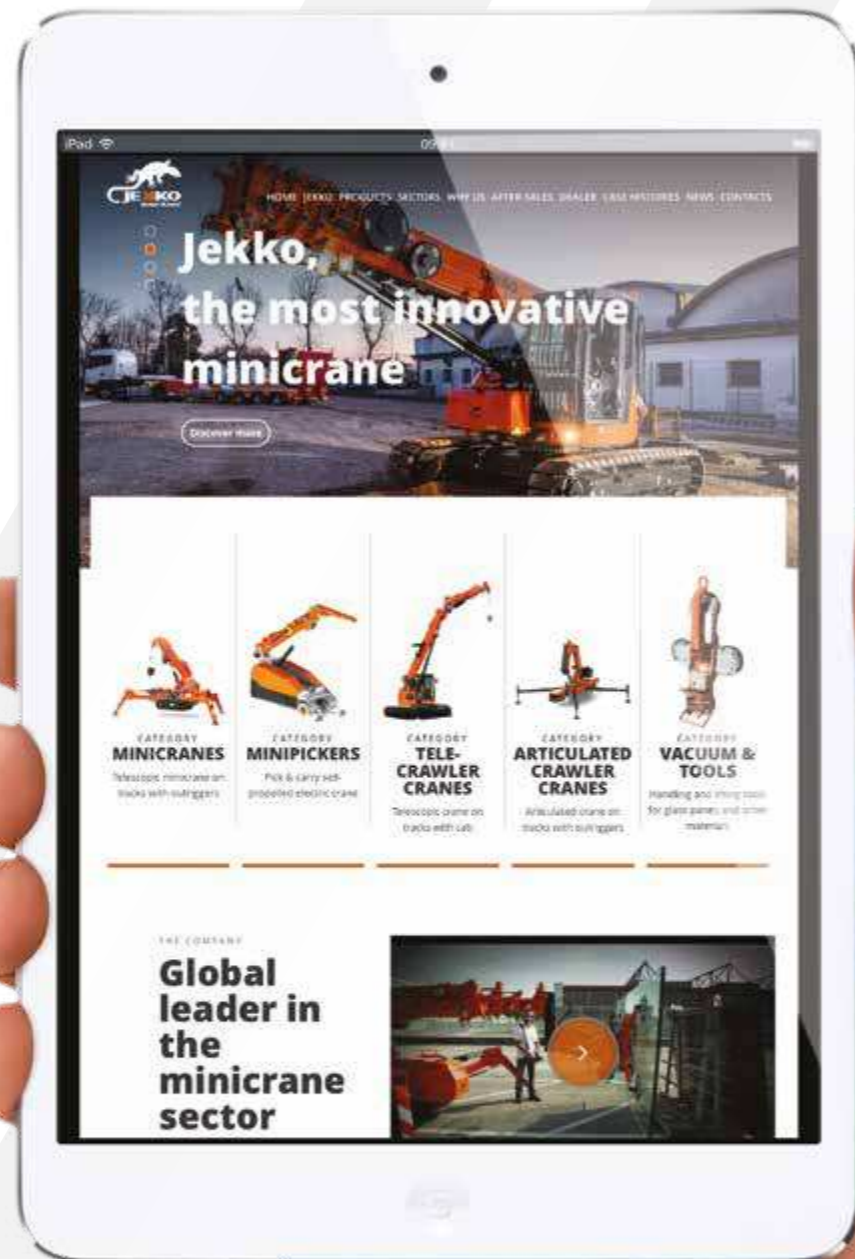



**Jekko srl**

Via Campardone, 1 - 31014 Colle Umberto (TV) Italy  
info@jekko.it - www.jekko.it