

# 1932R

ELECTRIC SCISSOR LIFT



## Performance

Platform Height–Elevated	19 ft	5.8 m
Platform Capacity	550 lb	250 kg
Capacity on Platform Extension	250 lb	113 kg
Lift/Lower Time	25/26 seconds	
Maximum Drive Height	Fully Elevated	
Weight*	2,630 lb	1,193 kg
Ground Bearing Pressure	101 psi	766 kg/cm <sup>2</sup>
Drive Speed–Elevated	0.5 mph	0.8 km/h
Drive Speed–Lowered	2 mph	3.2 km/h
Gradeability	25%	
Turning Radius (Inside)	Zero	Zero
Turning Radius (Outside)	66 in.	1.68 m

\* Certain options or country standards will increase weight.

## Standard Specifications

### Power Source

Batteries	4 x 6V 220 amp-hr
Charger	27 amp High Frequency Charger
Drive	Hydraulic Front-wheel

### Hydraulic Reservoir

• Capacity	4.5 gal.	17 L
• Pump	Fixed Displacement Gear	

### Tires

• Tire Size/Type (Non-Marking)	12 x 4 in.	323 x 100 mm
--------------------------------	------------	--------------

### Brakes

- Multi-Disc Friction

## Standard Features

- Proportional Controls
- Battery Condition Indicator
- 110V-AC Receptacle in Platform
- All Motion Alarm
- 27 amp Multi-Function Universal Charger
- Horn
- Hourmeter
- Tilt Alarm and Light
- Lanyard Attach Points
- Movable, Removable Platform Control
- Nickel Plated Pins
- Lubrication Free Scissor Arm Bushings
- Scissor Maintenance Prop
- Active Pothole Protection System
- Lifting and Tie Down Points
- Fork Lift Pockets
- 36 in. (91 cm) Foot-Actuated Deck Extension
- Steel Swing-Out Doors
- Variable Tilt Window
- Manual Descent Cable
- Diamond Tread Steel Deck
- Greaseless Kingpin Joints
- Analyzer Port for Diagnostics
- Dynamic Braking
- Removable Ladder



## Accessories & Options

- Flashing Amber Beacon
- 220 Amp-Hour AGM Batteries
- MDI (Ground)
- Self-Closing Gate
- Anti-Vandalism Package for Ground Controls and Platform Controls
- Eagle Performance Charger
- 1,000W-AC Inverter
- Ambient Noise Alarm

# 1932R

ELECTRIC SCISSOR LIFT



## Dimensions

All dimensions are approximate.

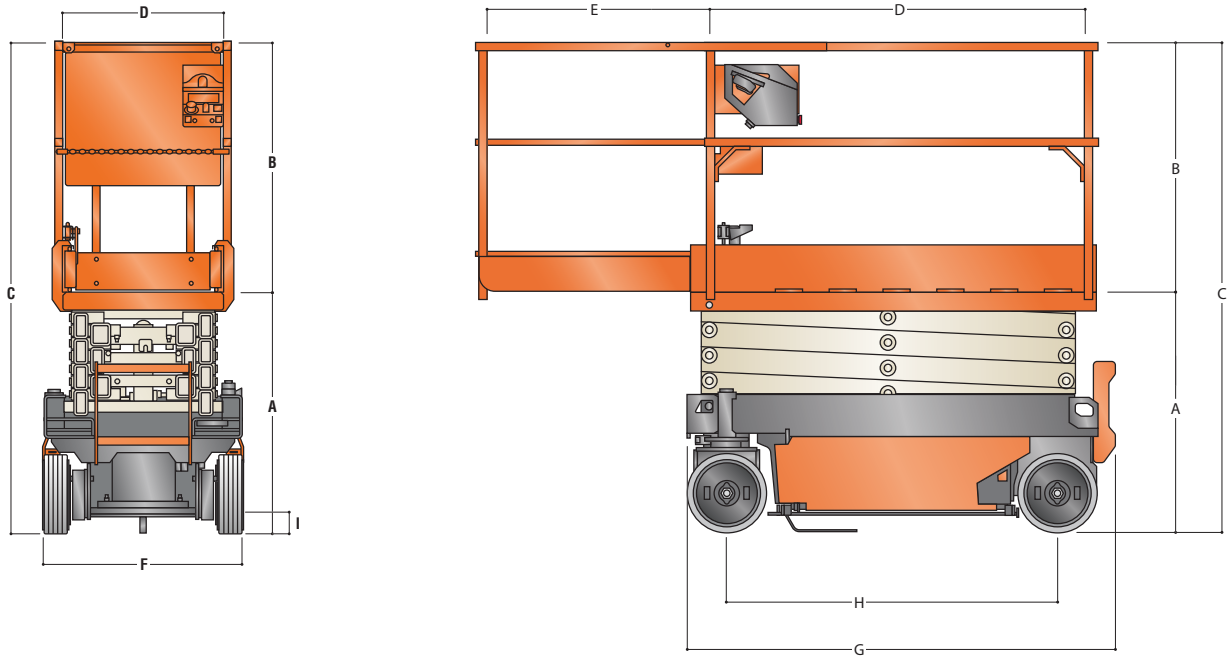

A. Platform Height-Lowered	38.6 in.	0.981 m
B. Platform Railing Height	39.9 in.	1.014 m
C. Overall Height	78.5 in.	1.99 m
D. Platform Size	25.4 in. x 62.7 in.	0.64 m x 1.59 m
E. Platform Extension	36 in.	0.91 m

F. Overall Width	32 in.	81 cm
G. Overall Length	68.7 in.	1.74 m
H. Wheelbase	53 in.	1.34 m
I. Ground Clearance	2.8 in.	7 cm

## The JLG "1 & 5" Warranty

JLG Industries, Inc. backs its products with its exclusive "1 & 5" Warranty. We provide coverage on all products for one (1) full year, and cover all specified major structural components for five (5) years. Due to continuous product improvements, we reserve the right to make specification and/or equipment changes without prior notification. This machine meets or exceeds applicable OSHA Regulations in 29 CFR 1910.67, 29 CFR 1926.453, ANSI A92.6, and CSA Standard CAN3-B354.2-M82, as originally manufactured for intended applications.

Part No.: 3131505  
R101601  
Printed in USA



**JLG Industries, Inc.**  
1 JLG Drive  
McCconnellsburg, PA 17233-9533  
Telephone 717-485-5161  
Toll-free in US 877-JLG-LIFT  
Fax 717-485-6417  
[www.jlg.com](http://www.jlg.com)

**An Oshkosh Corporation Company**