

# 450 SERIES II

ARTICULATING BOOM LIFTS



## Performance

Platform Height	45 ft	13.72 m
Horizontal Outreach	24 ft 6 in.	7.47 m
Up and Over Height	24 ft 10 in.	7.57 m
Swing	360 Degrees Non-Continuous	
Platform Capacity		
Unrestricted	500 lb	227 kg
Platform Size	30 x 72 in.	0.76 x 1.83 m
Platform Rotator	180 Degrees Hydraulic	
Jib (450AJ Only)	4 ft 1 in.	1.24 m
Range of Articulation	144 Degrees (+74, -70)	
Weight		
450A	12,750 lb	5,783 kg
450AJ	13,250 lb	6,010 kg
Max. Ground Bearing Pressure	65 psi	4.6 kg/cm <sup>2</sup>
Drive Speed		
2WD	3.5 mph	5.6 km/hr
4WD	4.5 mph	7.2 km/hr
Gradeability		
2WD	30%	
4WD	45%	
Axle Oscillation	4 in.	10.16 cm
Turning Radius		
Inside	6 ft 7 in.	2.0 m
Outside	16 ft 5 in.	5.0 m

## Standard Specifications

### Engine

Make and Model		
Dual Fuel Engine		
GM Vortec 3000 MPFI	82 hp	61 kW
Diesel Engine		
Deutz D2011L04	63.3 hp	47.2 kW
Fuel Tank Capacity	17 gal.	64 L

### Tires

Standard	33/1550 x 16.5 Superwide	
Optional	12 x 16.5 Lug Tread Tires	
	Foam-Filled Tires	
	Non-Marking Tires	

### Hydraulic System

Capacity	27 gal.	102.2 L
Auxiliary Power	12V DC	



## Standard Features

- 4 ft 1 in. (1.24 m) Articulating Jib (450AJ only)
- Platform 30 x 72 in. (0.76 x 1.83 m) Side Entry
- 180 Degree Hydraulic Platform Rotator
- Platform Console Machine Status Light Panel<sup>1</sup>
- 110V-AC Receptacle in the Platform
- 5 Degree Tilt Alarm/Indicator Light
- Rim Protector Lug Tread Tires
- Swing Out Engine Module
- Gull-wing Turntable Hoods
- 12V-DC Auxiliary Power
- Hourmeter
- Hydrostatic Drive
- Proportional Controls
- Control ADE<sup>®</sup> System
- Lifting/Tie Down Lugs
- Horn
- Oscillating Axle
- Cast Aluminum Control Box
- Motion Alarm

## Accessories & Options

- Inward Swinging Self Closing Gate
- Mesh to Top Rail — Bolt-on Aluminum
- 1/2 in. Air Line to Platform
- Soft Touch System
- AC Generator
- Flashing Amber Beacon
- 43.5 lb (19.73 kg) Propane Tank
- Cold Weather Kit<sup>2</sup>
- Hostile Environment Kit<sup>3</sup>
- Arctic Package<sup>4</sup>
- Light Package
- Platform Worklights
- Operator Tool Tray
- SkyPower<sup>®</sup> Package
- SkyWelder<sup>®</sup> Package
- SkyCutter<sup>®</sup> Package

1. Provides indicator lights at platform control console for system distress, low fuel, 5 degree tilt light, and foot switch status.
2. Includes battery blanket, hydraulic tank heater, block heater (Ford), glow plugs (Deutz).
3. Includes boom wipers, cylinder bellows and console cover.
4. Includes arctic hydraulic hoses (drive and steer only) and main boom cable, arctic hydraulic oil, extreme cold engine oil, fuel conditioner, engine block heater, battery blanket, glow plugs, hydraulic tank heater, and oversized footswitch.

Note: Some options may increase lead time, and some option combinations may not be available.

# 450 SERIES II

ARTICULATING BOOM LIFTS



## Dimensions

All dimensions are approximate.

### 450A

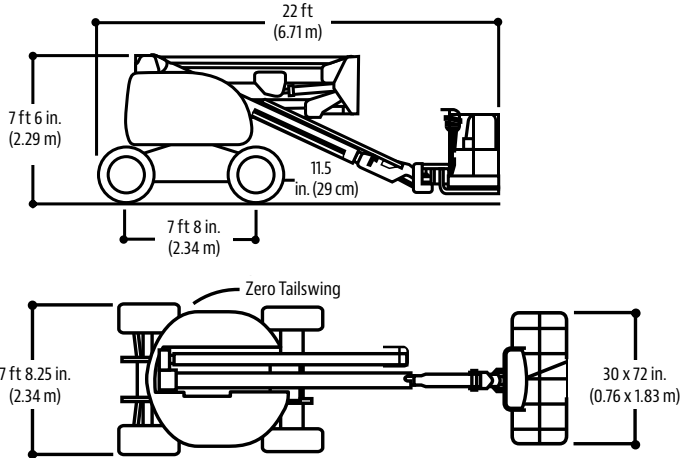

### 450AJ

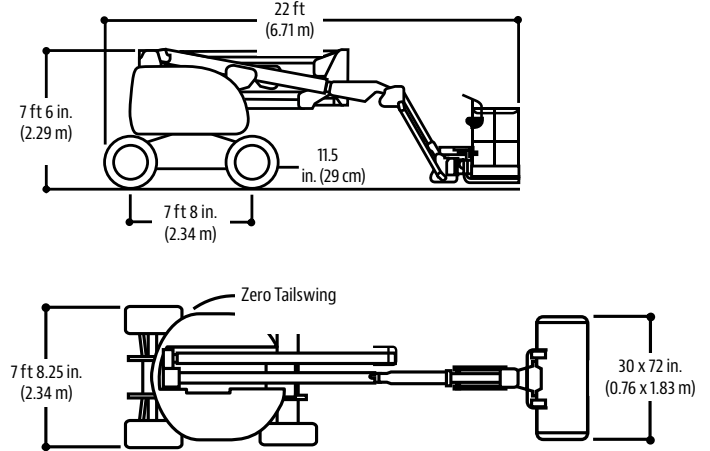

## Reach Diagrams

### 450A

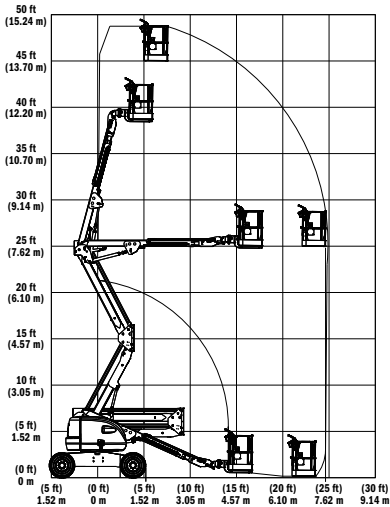

### 450AJ

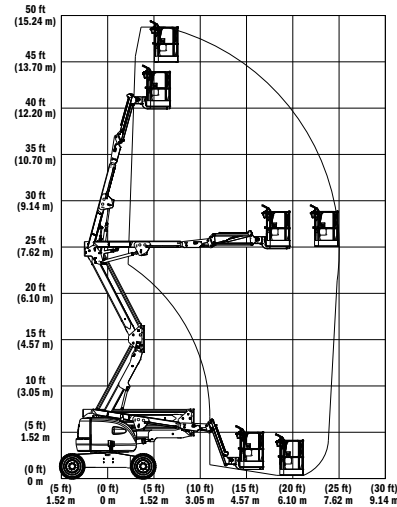

## The JLG "1 & 5" Warranty

JLG Industries, Inc. backs its products with its exclusive "1 & 5" Warranty. We provide coverage on all products for one (1) full year, and cover all specified major structural components for five (5) years. Due to continuous product improvements, we reserve the right to make specification and/or equipment changes without prior notification. This machine meets or exceeds applicable OSHA Regulations in 29 CFR 1910.67, 29 CFR 1926.453, ANSI A92.5-2006, and CSA Standard CAN3-B354.2-M82, as originally manufactured for intended applications.

Form No.: SS-450A-0107-10M  
 Part No.: 3131117  
 R041410  
 Printed in USA



**JLG Industries, Inc.**  
 1 JLG Drive  
 McConnellsburg, PA 17233-9533  
 Telephone 717-485-5161  
 Toll-free in US 877-JLG-LIFT  
 Fax 717-485-6417  
[www.jlg.com](http://www.jlg.com)

**An Oshkosh Corporation Company**