

Model 450 SERIES II

ARTICULATING BOOM LIFTS



Performance

Reach		
Platform Height	45 ft	13.72 m
Horizontal Outreach	24 ft 6 in.	7.47 m
Up and Over Height	24 ft 10 in.	7.57 m
Swing	360 Degrees Non-Continuous	
Platform Capacity		
Unrestricted	500 lb	227 kg
Platform Rotator		
Jib (450AJ Only)	180 Degrees Hydraulic	
	4 ft 1 in.	1.24 m
Range of Articulation		
	144 Degrees (+74, -70)	
Weight		
450A	12,750 lb	5,783 kg
450AJ	13,250 lb	6,010 kg
Max. Ground Bearing Pressure		
450A	65 psi	4.6 kg/cm ²
450AJ	65 psi	4.6 kg/cm ²
Drive Speed		
2WD	3.5 mph	5.6 kmph
4WD	4.5 mph	7.2 kmph
Gradeability		
2WD	30%	
4WD	45%	
Axle Oscillation		
	4 in.	10.16 cm
Turning Radius		
Inside	6 ft 7 in.	2.0 m
Outside	16 ft 5 in	5.0 m

Standard Specifications

Engine

Make and Model		
Dual Fuel Engine		
GM Vortec 3000 MPFI	82 hp	61 kW
Diesel Engine		
Deutz D2011L03	49 hp	36.4 kW
Fuel Tank Capacity	17 gal.	64 L

Tires

• Standard	33/1550 x 16.5 Superwide
• Optional	12 x 16.5 Lug Tread Tires Foam-Filled Tires Non-Marking Tires

Hydraulic System

• Capacity	27 gal.	102.2 L
• Auxiliary Power	12V DC	

Features

- 4 ft 1 in. (1.24 m) Articulating Jib (450AJ only)
- Platform 30 x 72 in. (0.76 x 1.83 m) Side Entry
- 180 Degree Hydraulic Platform Rotator
- Platform Console Machine Status Light Panel¹
- 110V-AC Receptacle in the Platform
- 5 Degree Tilt Alarm/Indicator Light
- Rim Protector Lug Tread Tires
- Swing Out Engine Module
- Gull-wing Turntable Hoods
- 12V-DC Auxiliary Power
- Hourmeter
- Hydrostatic Drive
- Proportional Controls
- Control ADE[®] System
- Lifting/Tie Down Lugs
- Horn
- Oscillating Axle
- Cast Aluminum Control Box
- Motion Alarm



Accessories & Options

- 30 x 60 in. (0.76 x 1.52 m) Platform
- Inward Swinging Self Closing Gate
- Mesh to Top Rail — Bolt-on Aluminum
- 1/2 in. Air Line to Platform
- Soft Touch System
- AC Generator
- Flashing Amber Beacon
- 43.5 lb (19.73 kg) Propane Tank
- Cold Weather Kit²
- Hostile Environment Kit³
- Arctic Package⁴
- Light Package
- Platform Worklights
- Operator Tool Tray
- Accessories
- SkyPower[®] Package
- SkyWelder[®] Package
- SkyCutter[®] Package

1. Provides indicator lights at platform control console for system distress, low fuel, 5 degree tilt light, and foot switch status.
 2. Includes battery blanket, hydraulic tank heater, block heater (Ford), glow plugs (Deutz).
 3. Includes boom wipers, cylinder bellows and console cover.
 4. Includes arctic hydraulic hoses (drive and steer only) and main boom cable, arctic hydraulic oil, extreme cold engine oil, fuel conditioner, engine block heater, battery blanket, glow plugs, hydraulic tank heater, and oversized footswitch.

Note: Some options may increase lead time, and some option combinations may not be available.

Model 450 SERIES II

ARTICULATING BOOM LIFTS

Dimensions

All dimensions are approximate.

450A

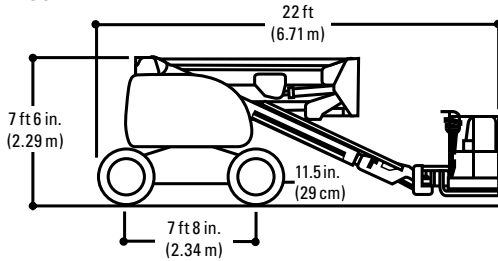

450AJ

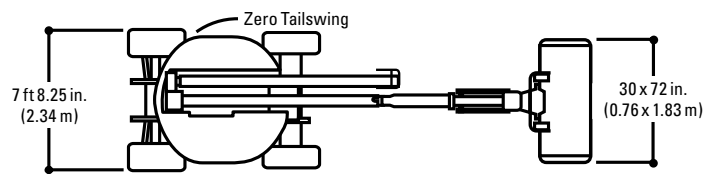
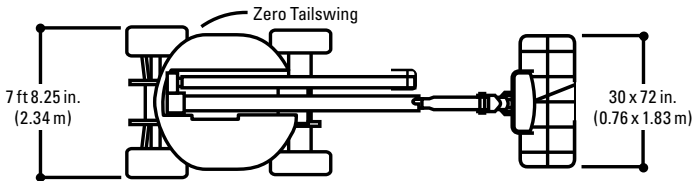
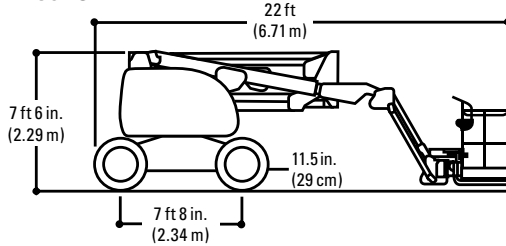

Reach Diagrams

450A

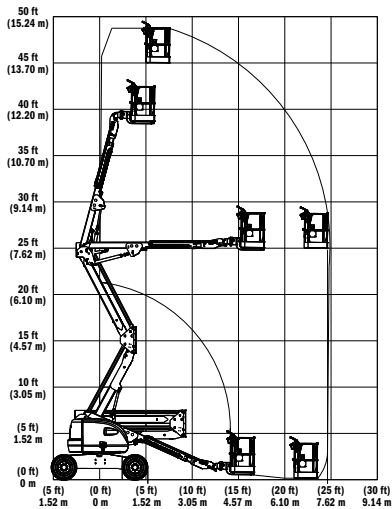

450AJ

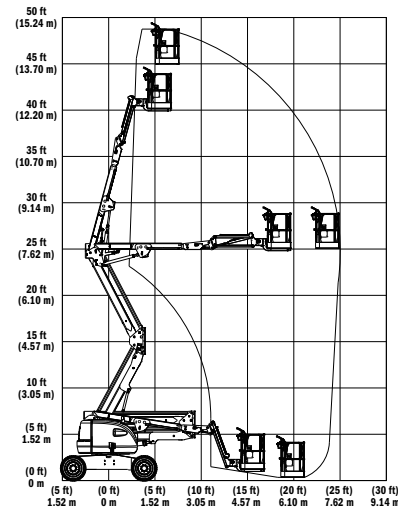

The JLG "1 & 5" Warranty

JLG Industries, Inc. backs its products with its exclusive "1 & 5" Warranty. We provide coverage on all products for one (1) full year, and cover all specified major structural components for five (5) years. Due to continuous product improvements, we reserve the right to make specification and/or equipment changes without prior notification. This machine meets or exceeds applicable OSHA Regulations in 29 CFR 1910.67, 29 CFR 1926.453, ANSI A92.5-2006, and CSA Standard CAN3-B354.2-M82, as originally manufactured for intended applications.

Form No.: SS-450A-0107-10M
Part No.: 3131117
R011309
Printed in USA

JLG Industries, Inc.
1 JLG Drive
McConnellsburg, PA 17233-9533
Telephone 717-485-5161
Toll-free in US 877-JLG-LIFT
Fax 717-485-6417
www.jlg.com

An Oshkosh Corporation Company