

E600 SERIES

ELECTRIC BOOM LIFTS



Performance

Platform Height		
E600J/M600J	60 ft 4 in.	18.39 m
E600JP/M600JP	60 ft 4 in.	18.39 m
Horizontal Outreach		
E600J/M600J	43 ft 3 in.	13.18 m
E600JP/M600JP	44 ft 5 in.	13.54 m
Swing	400° Non-Continuous	
Platform Capacity	500 lb	227 kg
Platform Rotator	180° Hydraulic	
Weight ¹		
E600J/M600J	15,200 lb	6,894 kg
E600JP/M600JP	15,750 lb	7,144 kg
Max. Ground Bearing Pressure		
E600J/M600J	52 psi	3.7 kg/cm ²
E600JP/M600JP	51 psi	3.6 kg/cm ²
Drive Speed	3.0 mph	4.8 km/h
Gradeability 2WD	30%	
Gradeability 4WD	45%	
Axle Oscillation	8 in.	20 cm
Turning Radius		
Inside	4 ft	1.22 m
Outside	15 ft 4 in.	4.67 m

1. Certain options or country standards increase weight.
2. Ground bearing pressure applies to standard tires.

Standard Specifications

Power Source

Electrical System	48V DC	
Batteries	8 x 6V, 415 amp-hr	
Drive Motors	Dual Electric Traction — Brushless AC	
Generator Set (M Models)		
Diesel Engine		
Kubota 45 amp	6.7 hp	4.99 kW
Fuel Tank Capacity	13 gal	49.21 L

Hydraulic System

• Capacity	15 gal	56.78 L
• Motor/pump	Series Wound Motor/Gear Pump	

Tires

• Standard	36 x 14-22.5 Non-Marking Pneumatic
------------	------------------------------------

Standard Features

- 6 ft (1.83 m) Articulating Jib
- 6 ft (1.83 m) Vertical and Lateral Articulating Jib (E/M600JP Only)
- Brushless AC Motors
- Operators Tool Tray
- Inward Self-Closing Swing Gate
- Platform Console Machine Status Light Panel¹
- 110V-AC GFI Receptacle in the Platform
- Tilt Light and Alarm



- Hourmeter
- Battery Condition Indicator
- Lifting/Tie Down Lugs
- 400 Degree Non-Continuous Rotation
- Removable Battery Box
- Oscillating Axle
- Manual Descent
- Automatic Traction Control (ATC)
- SCR Automatic Battery Charger
- All Motion Alarm

*Provides indicator lights at platform control console for system distress, fuel level, low fuel, 5 degree tilt light and foot switch status.

Accessories & Options

- 30 x 48 in. (0.76 x 1.22 m) Platform
- Mesh to Top Rail Bolt-on Aluminum
- Soft Touch System (E/M600J only)
- Platform Padding (30 x 72 in. Platform)
- 1/2 in. Airline to Platform
- Foam-Filled Tires
- 1200W Inverter
- Hostile Environment Kit¹
- UL[®] EE Rating²
- Tow Package³
- Light Package⁴
- Cold Weather Package, Diesel⁵
- Platform Worklights
- Flashing Amber Beacon

1. Includes console cover, boom wipers and cylinder bellows.
2. Not available on Multi-Powered models.
3. 2WD only.
4. Includes head and tail lights, and platform worklights.
5. Includes hydraulic tank heater, battery heater, and heater pad for block.

Note: Some options may increase lead time, and some option combinations may not be available.

E600 SERIES

ELECTRIC BOOM LIFTS



Dimensions

All dimensions are approximate.

E/M600J

E/M600JP

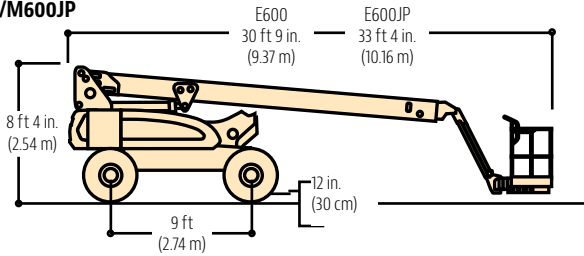

E/M600J

E/M600JP

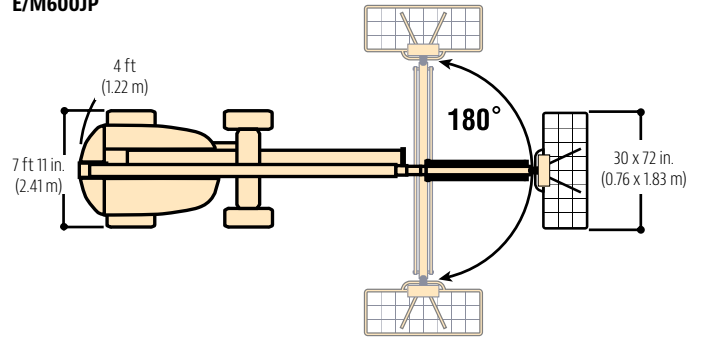

Reach Diagrams

E600J

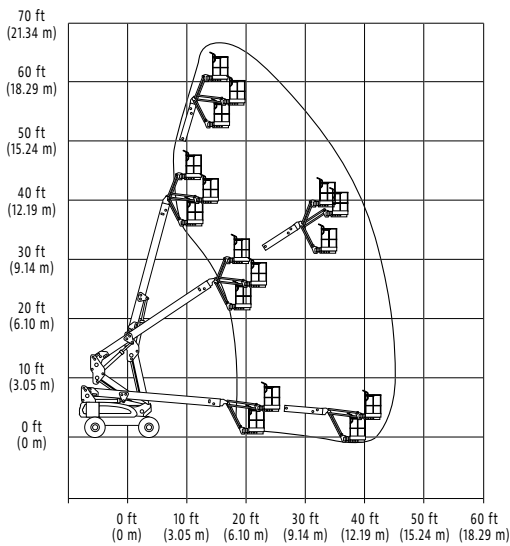

E600JP

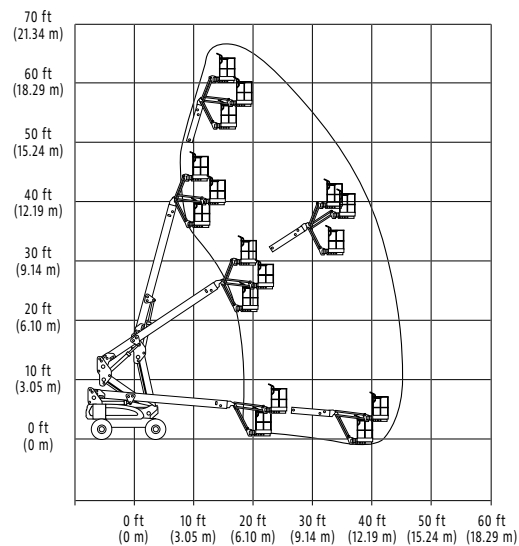

The JLG "1 & 5" Warranty

JLG Industries, Inc. backs its products with its exclusive "1 & 5" Warranty. We provide coverage on all products for one (1) full year, and cover all specified major structural components for five (5) years. Due to continuous product improvements, we reserve the right to make specification and/or equipment changes without prior notification. This machine meets or exceeds applicable OSHA Regulations in 29 CFR 1910.67, 29 CFR 1926.453, ANSI A92.5-2006, and CSA Standard CAN3-B354.2-M82, as originally manufactured for intended applications.

Part No.: 3131027
R071608
Printed in USA

JLG Industries, Inc.
1 JLG Drive
McCconnellsburg, PA 17233-9533
Telephone 717-485-5161
Toll-free in US 877-JLG-LIFT
Fax 717-485-6417
www.jlg.com

An Oshkosh Corporation Company