

# TOW-PRO® SERIES

TRAILER MOUNTED BOOM LIFTS



## Performance

Platform Height		
T350	34 ft 5 in.	10.5 m
T500J	50 ft 9.5 in.	15.3 m
Horizontal Outreach		
Working Outreach		
T350	20 ft 2 in.	6.15 m
T500J	31 ft 6 in.	9.6 m
Centerline to Platform Edge		
T350	18 ft 9.5 in.	5.7 m
T500J	29 ft 6 in.	9 m
From Outrigger Pad Edge		
T350	13 ft 6 in.	4.11 m
T500J	23 ft 5 in.	7.14 m
Up and Over Height		
T350	15 ft	4.57 m
T500J	18 ft	5.49 m
Swing		
	410 Degrees Non-Continuous	
Platform Capacity		
	500 lb	227 kg
Platform Capacity w/Rotator		
	440 lb	200 kg
Material Hook Capacity		
	500 lb	227 kg
Platform Rotator (Optional)		
	90 Degrees Manual	
Jib Length (T500J only)		
	4 ft	1.22 m
Jib Vertical Motion (T500J only)		
	130 degrees (+75, -55)	
Weight		
T350	3,400 lb	1,542 kg
T500J	4,800 lb	2,177 kg
Leveling Capability		
	11 Degrees	
Towing Speed Rating		
	65 mph	105 kmph
Tongue Weight		
T350	242 lb	110 kg
T500J	350 lb	159 kg

## Standard Specifications

### Power Source

DC Power	24V DC
Batteries	4 x 6V 220 amp-hr
Gasoline Engine (Optional)	Honda GX 270—9 hp

### Tires

- T350 205/75 R14 Pneumatic
- T500 225/75 R15 Pneumatic

## Standard Features

- Telescopic Upper Boom
- 4 ft (1.22 m) Jib (T500J Only)
- Platform, Side Entry: 30 x 48 in. (0.76 x 1.22 m)
- Proportional Controls
- 110V-AC Receptacle in the Platform
- Auto-Leveling Hydraulic Outriggers
- Motion Alarm
- Tilt Alarm/Indicator Light
- Hourmeter
- Four 6V 220 Amp-Hour Batteries
- Battery Condition Indicator
- Parking Brake
- 2 in. Hitch with Adjustable Height Coupler
- Standard Air and Water Lines to Platform



## Accessories & Options

- Platform Rotator
- Material Hook — 500 lb (227 kg) Capacity
- Drive and Outrigger Set
- Platform Mounted Glass/Panel Tray
- Non-Marking Outrigger Pads
- Full-Size Spare Tire
- Flashing Amber Beacon
- 3000 Watt Honda Generator

# TOW-PRO® SERIES

TRAILER MOUNTED BOOM LIFTS



## Dimensions

All dimensions are approximate.

T350

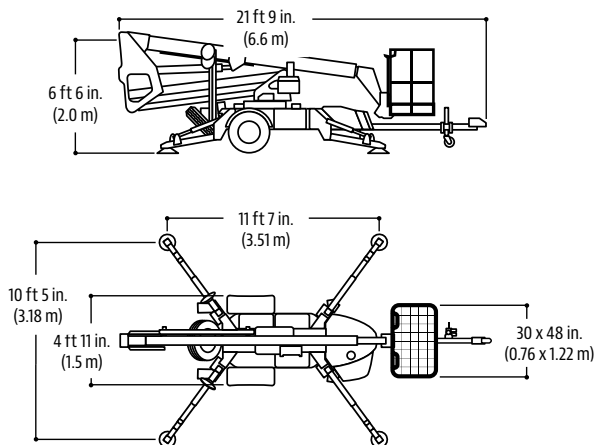

T500J

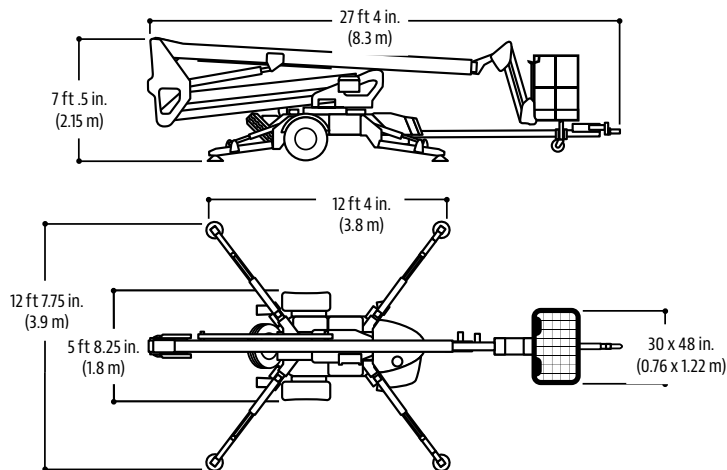

## Reach Dimensions

T350

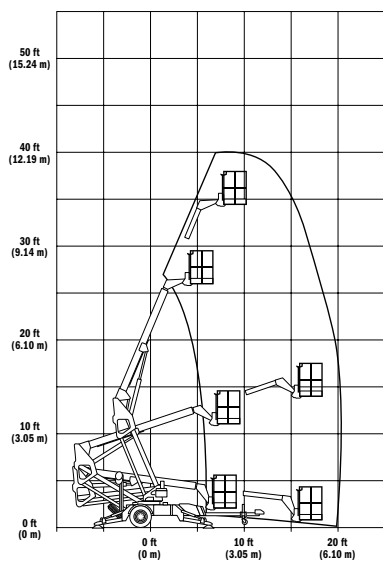

T500J

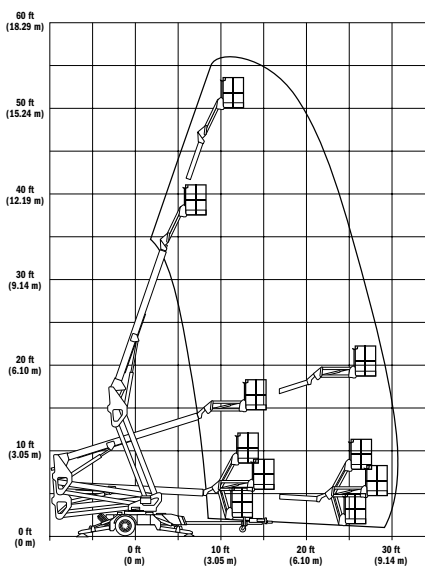

## The JLG "1 & 5" Warranty

JLG Industries, Inc. backs its products with its exclusive "1 & 5" Warranty. We provide coverage on all products for one (1) full year, and cover all specified major structural components for five (5) years. Due to continuous product improvements, we reserve the right to make specification and/or equipment changes without prior notification. This machine meets or exceeds applicable OSHA Regulations in 29 CFR 1910.67, 29 CFR 1926.453, ANSI A92.5-2006, and CSA Standard CAN3-B354.2-M82, as originally manufactured for intended applications.

Part No.: 3133001  
R071407  
Printed in USA



**JLG Industries, Inc.**  
1 JLG Drive  
McConnellsburg, PA 17233-9533  
Telephone 717-485-5161  
Toll-free in US 877-JLG-LIFT  
Fax 717-485-6417  
[www.jlg.com](http://www.jlg.com)

An Oshkosh Corporation Company