

# 210G/210G LC

22 451–23 560 kg (49,496–51,940 lb.) Operating Weight



**JOHN DEERE**





# Cover all the angles.

Whether you use them to excavate footings, load trucks, set stone, place pipe, or whatever, you'll get more done with a 210G or 210G LC. Rugged EPA Final Tier 4 (FT4)/EU Stage IV PowerTech™ diesel engines meet rigid emission regulations, enabling you to work, wherever there's work — without compromising power, reliability, or ease of operation. Direct greasing to the bushings and a round hydraulic-oil tank for even distribution help keep you running smooth. Upper-structure handrails and slip-resistant surfaces help maintain a solid footing. These are just some of the ways these able excavators have you covered.



	210G	210G LC
<b>Net rated power</b>	119 kW (159 hp)	119 kW (159 hp)
<b>Operating weight</b>	23 090 kg (50,905 lb.)	23 560 kg (51,940 lb.)
<b>Maximum digging depth</b>	6.67 m (21 ft. 11 in.)	6.67 m (21 ft. 11 in.)
<b>Arm digging force</b>	114 kN (25,628 lb.)	114 kN (25,628 lb.)
<b>Bucket digging force</b>	158 kN (35,520 lb.)	158 kN (35,520 lb.)

# Unearth more work.

With more arm force, bucket breakout force, and lift capacity, the 210G and 210G LC are impressive performers. But even with all of their extra muscle, their no-compromise Powerwise™ III hydraulic-management system yields the pinpoint metering and smooth-as-silk low-effort control that have become trademarks of our excavators.





Additional hydraulic capability a necessity? Two factory-installed high-pressure, high-flow auxiliary packages enable you to meet the need.

For work that requires extra finesse, short-throw low-effort controls, unmatched metering, and smooth multifunction operation give the precision you need.

Powerwise III perfectly balances engine performance and hydraulic flow for predictable operation. Three productivity modes allow you to choose the digging style that fits the job. **High productivity** delivers more power and faster hydraulic response to move more material. **Power** delivers a balance of power, speed, and fuel economy for normal operation. **Economy** reduces top speed and helps save fuel.



1. Standard TK-Series bucket teeth are engineered for maximum strength and impact absorption. Hammer-free installation and removal simplifies changes, minimizes downtime.
2. When the digging gets tough, simply press the power-boost button on the right-hand control and muscle through.
3. Choose from a variety of buckets, track widths, arm lengths, and other options.

The image shows the interior of a modern construction vehicle cab. The view is from the driver's perspective, looking towards the front. The cab is primarily grey and black, with yellow accents on the side panels. A large monitor is mounted on the left side of the dashboard, and a rotary control is visible on the right side of the dashboard. The steering wheel is on the right side. There are several warning labels on the dashboard, including one that says "DANGER" and another that says "WARNING". The overall appearance is clean and professional.

# Get in touch with your productive side.

Now it's easier than ever for your operators to "dial things up." The refined monitor employs a rotary control that makes it quick and easy to tap into an abundance of performance and convenience functions and features. Operators will also appreciate the quiet and spacious cab, virtually unobstructed all-around visibility, and numerous other amenities that provide everything your operators need to do their best work.



New hood design ensures optimal visibility to the sides and rear, even with the increased under-the-hood space requirements of EPA Final Tier 4 (FT4)/EU Stage IV components.

We've got your back with a sculpted mechanical-suspension high-back seat. Seat has 318 mm (12½ in.) of travel, sliding together or independent of the joystick console. So it won't cramp an operator's style. For even more support and comfort, opt for the air-suspension heated seat.

Available boom and cab lights illuminate the way when your workday extends beyond daylight hours (left-side boom light is standard).



1. Multi-language LCD monitor and rotary dial provide intuitive access to a wealth of information and functions. Just turn and tap to select work mode, access operating info, check maintenance intervals, source diagnostic codes, adjust cab temperature, and tune the radio. Plus much more.
2. Ergonomically correct short-throw pilot levers provide smooth, predictable fingertip control with less movement or effort. Push buttons in the right lever allow predictable control of auxiliary hydraulic flow for operating attachments. Optional sliding switch provides proportional speed control, giving you full command at your fingertips.
3. Automatic, high-velocity bi-level climate control system with automotive-style adjustable louvers helps keep the glass clear and the cab comfortable.



# Nothing runs like a Deere, because nothing is built like one.

Unlike some excavators that scream for attention, the hydraulically driven on-demand fans in our G-Series run only as fast as needed, for reduced noise and fuel consumption. Their highly efficient cooling systems keep things running cool, even in high-trash environments and high altitudes. When you know how they're built, you'll run a Deere.



A John Deere exclusive, three welded bulkheads within the boom resist torsional stress for unsurpassed durability. Booms, arms, and mainframes are so tough, they're warranted for three years or 10,000 hours.

Optional grade-reference system includes sensor mounts to help speed installation, eliminating the need to grind, weld, and repaint. Our "open-architecture" design allows you to employ your favorite brand of grade-control system to help maximize productivity and uptime while lowering daily operating costs.

To meet stringent EPA Final Tier 4 (FT4)/EU Stage IV standards, we built on our Interim Tier 4 (IT4)/Stage IIIB solution to deliver the best combination of performance, efficiency, and reliability without sacrificing power or torque. Our field-proven technology is simple, fluid efficient, fully integrated, and fully supported. It employs field-proven cooled exhaust gas recirculation (EGR), easy-to-maintain high-uptime exhaust filters, and selective catalytic reduction (SCR).



1. Highly efficient hydraulically driven fans run only as fast as needed, reducing noise, fuel consumption, and operating costs. Reversing option automatically back-blows cooler cores to keep them clean.

2. Thick-plate single-sheet mainframe, box-section track frames, and industry-exclusive double-seal swing bearing deliver rock-solid durability.

3. Reinforced D-channel side frames with recessed doors provide maximum cab and component protection.



# Uncover all the ways we keep costs down.

Like all John Deere machines, G-Series Excavators are loaded with features that make them hassle free to service and low cost to maintain.

1. Easy-to-read LCD monitor tracks scheduled maintenance intervals and issues reminders. Should a problem arise, it provides diagnostic information to help decrease downtime.
2. Diesel exhaust fluid (DEF) can be conveniently filled when refueling due to its large and accessible tank. DEF overflow routes excess outside the machine to avoid paint damage.
3. Large fuel tanks and 500- and 5,000-hour engine and hydraulic oil-service intervals decrease downtime for routine maintenance. Fluid-level sight gauges are conveniently located and can be checked at a glance.
4. Vertical spin-on fuel and engine oil filters are positioned in the right rear compartment for simplified ground-level servicing.
5. Ash-service intervals for the diesel particulate filter (DPF) are condition based, with the machine notifying the operator before service is required. Typically, ash service is not necessary until the first engine overhaul depending on machine application and maintenance practices. FT4 components are warranted for 10,000 hours.
6. Auto-idle automatically reduces engine speed when hydraulics aren't in use. Auto-shutdown further preserves precious fuel.

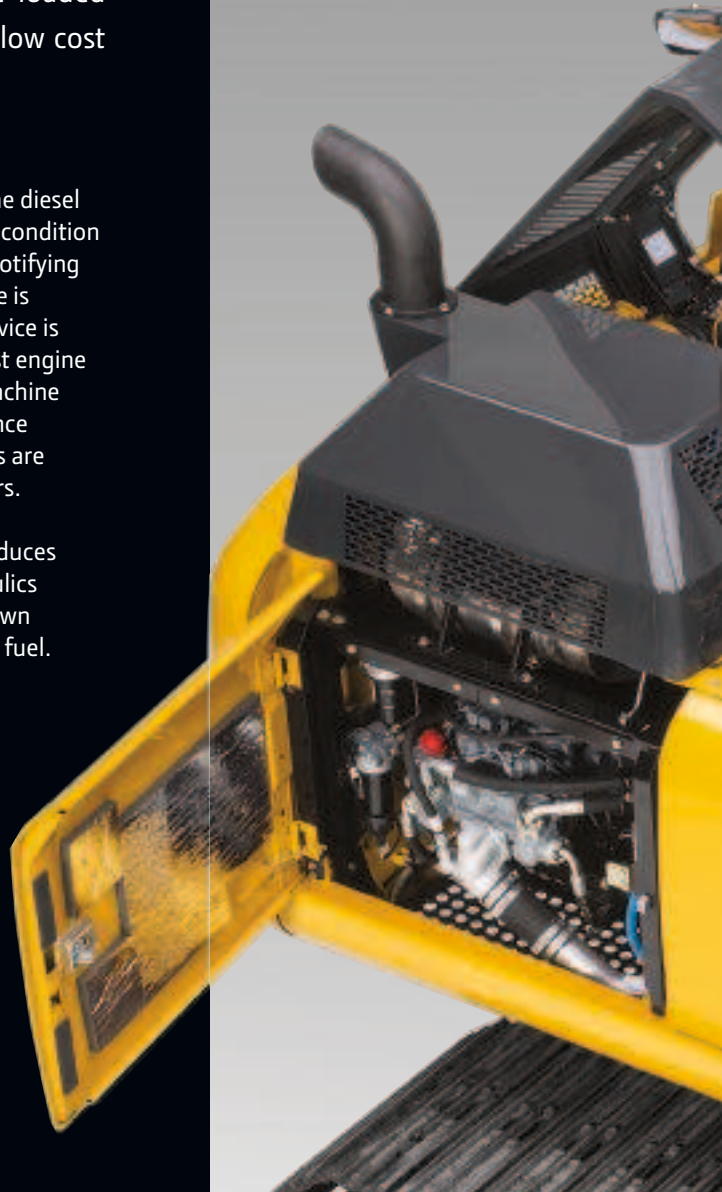

1	Engine Oil Filter
Previous Maintenance	
2015/04/07	0.0 h
Remains	375.8 h
Maintenance Interval	500.0 h



Courtesy of Machine.Market

Ultimate Uptime, featuring John Deere WorkSight™, is a customizable support solution available exclusively from your Deere dealer. This flexible offering maximizes equipment availability with standard John Deere WorkSight capabilities that can help prevent future downtime and speed repairs when needed. In addition to the

base John Deere WorkSight features, our dealers work with you to build an uptime package that meets the specific needs of your machine, fleet, project, and business, including customized maintenance and repair agreements, onsite parts availability, extended warranties, fluid sampling, response-time guarantees, and more.

John Deere WorkSight is an exclusive suite of telematic solutions that increases uptime while lowering operating costs. At its heart, JDLink™ Ultimate machine monitoring provides real-time utilization data and alerts to help you maximize productivity and efficiency while minimizing downtime. Remote diagnostics enable your dealer to read codes, record performance data, and even update software without a trip to the jobsite.

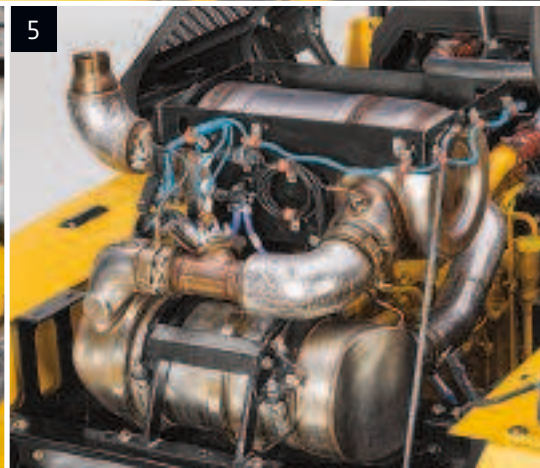

# 210G / 210G LC

<b>Engine</b>	<b>210G / 210G LC</b>		
	<i>Base engine for use in U.S., U.S. Territories, and Canada</i>		
Manufacturer and Model	John Deere PowerTech™ PVS 6.8L 6068HT106		
Non-Road Emission Standard	EPA Final Tier 4/EU Stage IV		
Net Rated Power (ISO 9249)	119 kW (159 hp) at 2,000 rpm		
Cylinders	6		
Displacement	6.8L (415 cu. in.)		
Off-Level Capacity	70% (35 deg.)		
Aspiration	Turbocharged, air-to-air charge-air cooler		
<b>Cooling</b>			
	Cool-on-demand hydraulic-driven, suction-type fan with remote-mounted drive		
<b>Powertrain</b>			
	2-speed propel with automatic shift		
<b>Maximum Travel Speed</b>			
Low	3.5 km/h (2.2 mph)		
High	5.5 km/h (3.4 mph)		
Drawbar Pull (turtle mode)	20 700 kg (45,636 lb.)		
<b>Hydraulics</b>			
	Open center, load sensing		
<b>Main Pumps</b>	2 variable-displacement axial-piston pumps		
Maximum Rated Flow	212 L/m (56 gpm) x 2		
<b>Pilot Pump</b>	1 gear		
Maximum Rated Flow	30 L/m (7.9 gpm)		
Pressure Setting	4000 kPa (580 psi)		
<b>System Operating Pressure</b>			
Circuits			
Implement	34 300 kPa (4,975 psi)		
Travel	35 500 kPa (5,149 psi)		
Swing	33 300 kPa (4,830 psi)		
Power Boost	38 000 kPa (5,511 psi)		
<b>Controls</b>	Pilot levers, short stroke, low-effort hydraulic pilot controls with shutoff lever		
<b>Cylinders</b>			
	<i>Bore</i>	<i>Rod Diameter</i>	<i>Stroke</i>
<b>Boom (2)</b>	120 mm (4.7 in.)	85 mm (3.3 in.)	1260 mm (49.6 in.)
<b>Arm (1)</b>	135 mm (5.3 in.)	95 mm (3.7 in.)	1475 mm (58.1 in.)
<b>Bucket (1)</b>	115 mm (4.5 in.)	80 mm (3.1 in.)	1060 mm (41.7 in.)
<b>Electrical</b>			
Number of Batteries (12 volt)	2		
Battery Capacity	1,000 CCA		
Alternator Rating	100 amp		
Work Lights	2 halogen (1 mounted on left-hand side of boom, 1 on frame)		
<b>Undercarriage</b>	<b>210G</b>	<b>210G LC</b>	
<b>Rollers (each side)</b>			
Carrier	2	2	
Track	7	8	
Shoes, Triple Semi-Grousers (each side)	46	49	
<b>Track</b>			
Adjustment	Hydraulic	Hydraulic	
Guides	Center	Center	
Chain	Sealed and lubricated	Sealed and lubricated	
<b>Ground Pressure</b>			
Triple Semi-Grouser Shoes			
600 mm (24 in.)	48.8 kPa (7.08 psi)	44.4 kPa (6.44 psi)	
700 mm (28 in.)	42.5 kPa (6.16 psi)	39.3 kPa (5.71 psi)	
800 mm (32 in.)	37.7 kPa (5.47 psi)	34.4 kPa (4.99 psi)	



<b>Swing Mechanism</b>	<b>210G / 210G LC</b>	
Speed	13.3 rpm	
Torque	68 900 Nm (50,662 lb.-ft.)	

**Serviceability**

<b>Refill Capacities</b>		
Fuel Tank	403 L (106.5 gal.)	
Cooling System	35.4 L (9.4 gal.)	
Engine Oil with Filter	20.8 L (5.5 gal.)	
Hydraulic Tank	135 L (35.7 gal.)	
Hydraulic System	240 L (63.4 gal.)	
<b>Gearbox</b>		
Swing	6.2 L (6.6 qt.)	
Propel (each)	7.8 L (8.2 qt.)	
Pump Drive	1 L (1.1 qt.)	
Diesel Exhaust Fluid (DEF) Tank	26.6 L (7.0 gal.)	

<b>Operating Weights</b>	<b>210G</b>	<b>210G LC</b>
--------------------------	-------------	----------------

With full fuel tank; 79-kg (175 lb.) operator; 1065-mm (42 in.), 0.91-m<sup>3</sup> (1.19 cu. yd.), 886-kg (1,951 lb.) general-purpose bucket; 2.91-m (9 ft. 7 in.) arm; and 4250-kg (9,370 lb.) counterweight

<b>With Triple Semi-Grouser Shoes</b>		
800 mm (32 in.)	23 090 kg (50,905 lb.)	23 560 kg (51,940 lb.)
700 mm (28 in.)	22 791 kg (50,246 lb.)	23 247 kg (51,251 lb.)
600 mm (24 in.)	22 451 kg (49,496 lb.)	22 857 kg (50,391 lb.)

**Component Weights**

Undercarriage with Triple Semi-Grouser Shoes	<i>Standard</i>	<i>LC</i>
600 mm (24 in.)	6929 kg (15,262 lb.)	7335 kg (16,156 lb.)
700 mm (28 in.)	7269 kg (16,011 lb.)	7725 kg (17,015 lb.)
800 mm (32 in.)	7568 kg (16,670 lb.)	8038 kg (17,705 lb.)
1-Piece Boom (with arm cylinder)	1731 kg (3,813 lb.)	1731 kg (3,813 lb.)
<b>Arm with Bucket Cylinder and Linkage</b>		
2.42 m (7 ft. 3 in.)	935 kg (2,059 lb.)	935 kg (2,059 lb.)
2.91 m (9 ft. 7 in.)	1001 kg (2,205 lb.)	1001 kg (2,205 lb.)
Boom-Lift Cylinders (2), Total Weight	354 kg (780 lb.)	354 kg (780 lb.)
Counterweight, Standard	4250 kg (9,370 lb.)	4250 kg (9,370 lb.)

**Operating Dimensions**

<b>210G / 210G LC</b>		
<b>Arm Length</b>	<i>2.42 m (7 ft. 11 in.)</i>	<i>2.91 m (9 ft. 7 in.)</i>
<b>Arm Digging Force</b>		
SAE	133 kN (29,900 lbf)	110 kN (24,729 lbf)
ISO	140 kN (31,473 lbf)	114 kN (25,628 lbf)
<b>Bucket Digging Force</b>		
SAE	141 kN (31,698 lbf)	141 kN (31,698 lbf)
ISO	158 kN (35,520 lbf)	158 kN (35,520 lbf)
<b>A</b> Maximum Reach	9.43 m (30 ft. 11 in.)	9.92 m (32 ft. 7 in.)
<b>A'</b> Maximum Reach at Ground Level	9.25 m (30 ft. 4 in.)	9.75 m (32 ft. 0 in.)
<b>B</b> Maximum Digging Depth	6.18 m (20 ft. 3 in.)	6.67 m (21 ft. 11 in.)
<b>B'</b> Maximum Digging Depth at 2.44-m (8 ft. 0 in.) Flat Bottom	5.95 m (19 ft. 6 in.)	6.50 m (21 ft. 4 in.)
<b>C</b> Maximum Cutting Height	9.67 m (31 ft. 9 in.)	10.04 m (32 ft. 11 in.)
<b>D</b> Maximum Dumping Height	6.83 m (22 ft. 5 in.)	7.18 m (23 ft. 7 in.)
<b>E</b> Minimum Swing Radius	3.18 m (10 ft. 5 in.)	3.18 m (10 ft. 5 in.)
<b>F</b> Maximum Vertical Wall	5.30 m (17 ft. 5 in.)	5.99 m (19 ft. 8 in.)

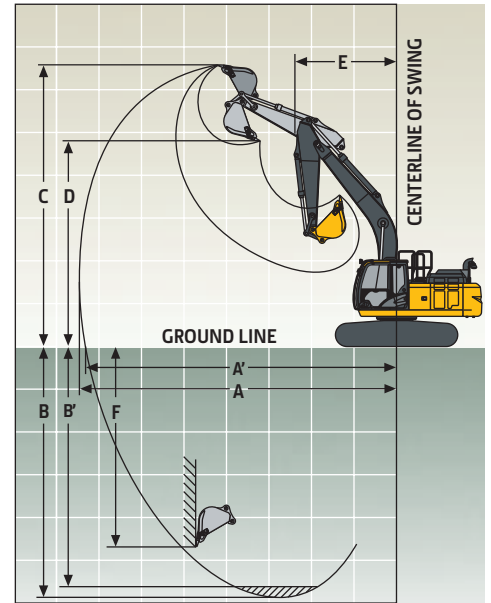

Machine Dimensions	210G		210G LC	
<b>Arm Length</b>	2.42 m (7 ft. 11 in.)	2.91 m (9 ft. 7 in.)	2.42 m (7 ft. 11 in.)	2.91 m (9 ft. 7 in.)
<b>A Overall Length</b>	9.75 m (32 ft. 0 in.)	9.53 m (31 ft. 3 in.)	9.75 m (32 ft. 0 in.)	9.66 m (31 ft. 8 in.)
<b>B Overall Height</b>	3.18 m (10 ft. 5 in.)	3.01 m (9 ft. 11 in.)	3.18 m (10 ft. 5 in.)	3.01 m (9 ft. 11 in.)
<b>C Rear-End Length/Swing Radius</b>	2.89 m (9 ft. 6 in.)	2.89 m (9 ft. 6 in.)	2.89 m (9 ft. 6 in.)	2.89 m (9 ft. 6 in.)
<b>D Distance Between Idler/Sprocket Centerline</b>	3.35 m (11 ft. 0 in.)	3.35 m (11 ft. 0 in.)	3.66 m (12 ft. 0 in.)	3.66 m (12 ft. 0 in.)
<b>E Undercarriage Length</b>	4.17 m (13 ft. 8 in.)	4.17 m (13 ft. 8 in.)	4.47 m (14 ft. 8 in.)	4.47 m (14 ft. 8 in.)
<b>F Counterweight Clearance</b>	1030 mm (3 ft. 5 in.)	1030 mm (3 ft. 5 in.)	1030 mm (3 ft. 5 in.)	1030 mm (3 ft. 5 in.)
<b>G Upperstructure Width</b>	2.71 m (8 ft. 11 in.)	2.71 m (8 ft. 11 in.)	2.71 m (8 ft. 11 in.)	2.71 m (8 ft. 11 in.)
<b>H Cab Height</b>	2.95 m (9 ft. 8 in.)	2.95 m (9 ft. 8 in.)	2.95 m (9 ft. 8 in.)	2.95 m (9 ft. 8 in.)
<b>I Track Width with Triple Semi-Grouser Shoes</b>	600 mm (24 in.) / 700 mm (28 in.) / 800 mm (32 in.)	600 mm (24 in.) / 700 mm (28 in.) / 800 mm (32 in.)	600 mm (24 in.) / 700 mm (28 in.) / 800 mm (32 in.)	600 mm (24 in.) / 700 mm (28 in.) / 800 mm (32 in.)
<b>J Gauge Width</b>	2.22 m (7 ft. 3 in.)	2.22 m (7 ft. 3 in.)	2.39 m (7 ft. 10 in.)	2.39 m (7 ft. 10 in.)
<b>K Ground Clearance</b>	450 mm (17.72 in.)	450 mm (17.72 in.)	450 mm (17.72 in.)	450 mm (17.72 in.)
<b>L Overall Width with Triple Semi-Grouser Shoes</b>				
600 mm (24 in.)	2.82 m (9 ft. 3 in.)	2.82 m (9 ft. 3 in.)	2.99 m (9 ft. 10 in.)	2.99 m (9 ft. 10 in.)
700 mm (28 in.)	2.92 m (9 ft. 7 in.)	2.92 m (9 ft. 7 in.)	3.09 m (10 ft. 2 in.)	3.09 m (10 ft. 2 in.)
800 mm (32 in.)	3.02 m (9 ft. 11 in.)	3.02 m (9 ft. 11 in.)	3.19 m (10 ft. 6 in.)	3.19 m (10 ft. 6 in.)

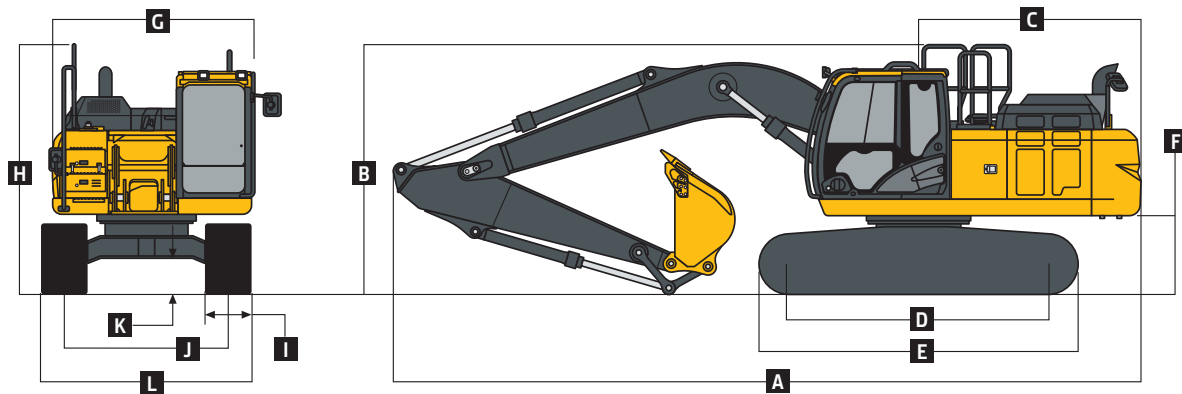

210G / 210G LC EXCAVATORS

### 210G Lift Capacities

**Boldface type** indicates hydraulically limited capacity; lightface type indicates stability-limited capacities, in kg (lb.). Ratings at bucket lift hook; machine equipped with 666-kg (1,468 lb.) bucket, standard counterweight, and standard gauge; and situated on firm, level, uniform supporting surface. Total load includes weight of cables, hook, etc. Figures do not exceed 87 percent of hydraulic capacities or 75 percent of weight needed to tip machine. All lift capacities are based on ISO 10567 (with power boost).

LOAD POINT HEIGHT	HORIZONTAL DISTANCE FROM CENTERLINE OF ROTATION									
	1.5 m (5 ft.)		3.0 m (10 ft.)		4.5 m (15 ft.)		6.0 m (20 ft.)		7.5 m (25 ft.)	
	Over Front	Over Side	Over Front	Over Side	Over Front	Over Side	Over Front	Over Side	Over Front	Over Side
<i>With 2.42-m (7 ft. 11 in.) arm and 800-mm (32 in.) triple semi-grouser shoes</i>										
6.0 m (20 ft.)							5170 <b>(11,380)</b>	4570 (9,800)		
4.5 m (15 ft.)					6760 <b>(14,560)</b>	6760 <b>(14,560)</b>	5650 <b>(12,290)</b>	4420 (9,510)		
3.0 m (10 ft.)			20,290 <b>(20,290)</b>	20,290 <b>(20,290)</b>	8630 <b>(18,560)</b>	6520 (14,080)	6460 <b>(13,990)</b>	4200 (9,040)	4620 (9,920)	2910 (6,240)
1.5 m (5 ft.)					10 140 <b>(21,880)</b>	6100 (13,150)	6420 (13,810)	3990 (8,590)	4510 (9,710)	2810 (6,050)
Ground Line					9980 (21,410)	5910 (12,730)	6270 (13,480)	3850 (8,300)	4450 (9,570)	2750 (5,920)
-1.5 m (-5 ft.)		9330 <b>(21,390)</b>	9330 <b>(21,390)</b>		9950 (21,360)	5890 (12,680)	6230 (13,400)	3820 (8,220)		
-3.0 m (-10 ft.)		12 640 <b>(27,400)</b>	11 810		9150 <b>(19,750)</b>	6000 (12,910)	6320 (13,620)	3900 (8,420)		
-4.5 m (-15 ft.)					6300 <b>(13,030)</b>	6280 <b>(13,030)</b>				

## 210G Lift Capacities (continued)

**Boldface type** indicates hydraulically limited capacity; lightface type indicates stability-limited capacities, in kg (lb.). Ratings at bucket lift hook; machine equipped with 666-kg (1,468 lb.) bucket, standard counterweight, and standard gauge; and situated on firm, level, uniform supporting surface. Total load includes weight of cables, hook, etc. Figures do not exceed 87 percent of hydraulic capacities or 75 percent of weight needed to tip machine. All lift capacities are based on ISO 10567 (with power boost).

LOAD POINT HEIGHT	HORIZONTAL DISTANCE FROM CENTERLINE OF ROTATION									
	1.5 m (5 ft.)		3.0 m (10 ft.)		4.5 m (15 ft.)		6.0 m (20 ft.)		7.5 m (25 ft.)	
	Over Front	Over Side	Over Front	Over Side	Over Front	Over Side	Over Front	Over Side	Over Front	Over Side
<i>With 2.91-m (9 ft. 7 in.) arm and 600-mm (24 in.) triple semi-grouser shoes</i>										
6.0 m (20 ft.)							<b>4650</b>	4530		
							<b>(10,210)</b>	(9,720)		
4.5 m (15 ft.)					<b>6030</b>	<b>6030</b>	<b>5200</b>	4370	<b>4610</b>	2940
					<b>(13,010)</b>	<b>(13,010)</b>	<b>(11,310)</b>	(9,400)	<b>(9,890)</b>	(6,300)
3.0 m (10 ft.)					<b>7950</b>	6510	<b>6070</b>	4140	4500	2840
					<b>(17,100)</b>	(14,040)	<b>(13,150)</b>	(8,910)	<b>(9,670)</b>	(6,100)
1.5 m (5 ft.)					<b>9680</b>	6030	<b>6270</b>	3910	4380	2730
					<b>(20,880)</b>	(12,990)	<b>(13,480)</b>	(8,410)	<b>(9,420)</b>	(5,860)
Ground Line			<b>4270</b>	<b>4270</b>	9720	5770	6090	3740	4290	2640
			<b>(9,930)</b>	<b>(9,930)</b>	(20,860)	(12,420)	(13,090)	(8,060)	<b>(9,220)</b>	(5,680)
-1.5 m (-5 ft.)	<b>4900</b>	<b>4900</b>	<b>8520</b>	<b>8520</b>	9630	5700	6010	3670	4260	2620
	<b>(11,010)</b>	<b>(11,010)</b>	<b>(19,440)</b>	<b>(19,440)</b>	(20,670)	(12,250)	(12,920)	(7,910)	<b>(9,170)</b>	(5,640)
-3.0 m (-10 ft.)	<b>9390</b>	<b>9390</b>	<b>13 810</b>	11 360	<b>9650</b>	5760	6050	3710		
	<b>(21,140)</b>	<b>(21,140)</b>	<b>(29,920)</b>	(24,350)	<b>(20,830)</b>	(12,390)	<b>(13,020)</b>	(7,990)		
-4.5 m (-15 ft.)			<b>10 680</b>	<b>10 680</b>	<b>7540</b>	5960				
			<b>(22,820)</b>	<b>(22,820)</b>	<b>(16,000)</b>	(12,860)				
<i>With 2.91-m (9 ft. 7 in.) arm and 700-mm (28 in.) triple semi-grouser shoes</i>										
6.0 m (20 ft.)							<b>4650</b>	4600		
							<b>(10,210)</b>	(9,890)		
4.5 m (15 ft.)					<b>6030</b>	<b>6030</b>	<b>5200</b>	4450	4710	3000
					<b>(13,010)</b>	<b>(13,010)</b>	<b>(11,310)</b>	(9,560)	<b>(10,090)</b>	(6,420)
3.0 m (10 ft.)					<b>7950</b>	6620	<b>6070</b>	4210	4600	2900
					<b>(17,100)</b>	(14,280)	<b>(13,150)</b>	(9,070)	<b>(9,870)</b>	(6,220)
1.5 m (5 ft.)					<b>9680</b>	6140	6390	3980	4470	2790
					<b>(20,880)</b>	(13,230)	<b>(13,750)</b>	(8,570)	<b>(9,620)</b>	(5,980)
Ground Line			<b>4270</b>	<b>4270</b>	9910	5880	6210	3820	4380	2700
			<b>(9,930)</b>	<b>(9,930)</b>	(21,270)	(12,650)	(13,360)	(8,220)	<b>(9,420)</b>	(5,810)
-1.5 m (-5 ft.)	<b>4900</b>	<b>4900</b>	<b>8520</b>	<b>8520</b>	9830	5810	6130	3750	4350	2680
	<b>(11,010)</b>	<b>(11,010)</b>	<b>(19,440)</b>	<b>(19,440)</b>	(21,080)	(12,490)	(13,190)	(8,070)	<b>(9,380)</b>	(5,760)
-3.0 m (-10 ft.)	<b>9390</b>	<b>9390</b>	<b>13 810</b>	11 560	<b>9650</b>	5870	6170	3780		
	<b>(21,140)</b>	<b>(21,140)</b>	<b>(29,920)</b>	(24,780)	<b>(20,840)</b>	(12,620)	<b>(13,290)</b>	(8,150)		
-4.5 m (-15 ft.)			<b>10 680</b>	<b>10 680</b>	<b>7540</b>	6070				
			<b>(22,820)</b>	<b>(22,820)</b>	<b>(16,000)</b>	(13,100)				
<i>With 2.91-m (9 ft. 7 in.) arm and 800-mm (32 in.) triple semi-grouser shoes</i>										
6.0 m (20 ft.)							<b>4650</b>	4640		
							<b>(10,210)</b>	(9,960)		
4.5 m (15 ft.)					<b>6030</b>	<b>6030</b>	<b>5200</b>	4480	4750	3020
					<b>(13,010)</b>	<b>(13,010)</b>	<b>(11,310)</b>	(9,640)	<b>(10,190)</b>	(6,480)
3.0 m (10 ft.)					<b>7950</b>	6670	<b>6070</b>	4250	4640	2920
					<b>(17,100)</b>	(14,380)	<b>(13,150)</b>	(9,140)	<b>(9,970)</b>	(6,280)
1.5 m (5 ft.)					<b>9680</b>	6180	6450	4010	4520	2810
					<b>(20,880)</b>	(13,330)	<b>(13,880)</b>	(8,640)	<b>(9,710)</b>	(6,040)
Ground Line			<b>4270</b>	<b>4270</b>	10 000	5920	6270	3850	4420	2730
			<b>(9,930)</b>	<b>(9,930)</b>	(21,460)	(12,760)	(13,480)	(8,290)	<b>(9,520)</b>	(5,860)
-1.5 m (-5 ft.)	<b>4900</b>	<b>4900</b>	<b>8520</b>	<b>8520</b>	9910	5850	6190	3780	4400	2700
	<b>(11,010)</b>	<b>(11,010)</b>	<b>(19,440)</b>	<b>(19,440)</b>	(21,270)	(12,590)	(13,320)	(8,140)	<b>(9,470)</b>	(5,820)
-3.0 m (-10 ft.)	<b>9390</b>	<b>9390</b>	<b>13 810</b>	11 650	<b>9650</b>	5910	6230	3820		
	<b>(21,140)</b>	<b>(21,140)</b>	<b>(29,920)</b>	(24,970)	<b>(20,840)</b>	(12,730)	<b>(13,410)</b>	(8,220)		
-4.5 m (-15 ft.)			<b>10 680</b>	<b>10 680</b>	<b>7540</b>	6120				
			<b>(22,820)</b>	<b>(22,820)</b>	<b>(16,000)</b>	(13,200)				

## 210G LC Lift Capacities

**Boldface type** indicates hydraulically limited capacity; lightface type indicates stability-limited capacities, in kg (lb.). Ratings at bucket lift hook; machine equipped with 666-kg (1,468 lb.) bucket, standard counterweight, and standard gauge; and situated on firm, level, uniform supporting surface. Total load includes weight of cables, hook, etc. Figures do not exceed 87 percent of hydraulic capacities or 75 percent of weight needed to tip machine. All lift capacities are based on ISO 10567 (with power boost).

LOAD POINT HEIGHT	HORIZONTAL DISTANCE FROM CENTERLINE OF ROTATION									
	1.5 m (5 ft.)		3.0 m (10 ft.)		4.5 m (15 ft.)		6.0 m (20 ft.)		7.5 m (25 ft.)	
	Over Front	Over Side	Over Front	Over Side	Over Front	Over Side	Over Front	Over Side	Over Front	Over Side
<i>With 2.42-m (7 ft. 11 in.) arm and 800-mm (32 in.) triple semi-grouser shoes</i>										
6.0 m (20 ft.)							<b>5170</b>	5100		
							<b>(11,380)</b>	(10,950)		
4.5 m (15 ft.)					<b>6760</b>	<b>6760</b>	<b>5650</b>	4950		
			<b>(20,290)</b>	<b>(20,290)</b>	<b>(14,560)</b>	<b>(14,560)</b>	<b>(12,290)</b>	(10,660)		
3.0 m (10 ft.)					<b>8630</b>	7370	<b>6460</b>	4730	5270	3290
					<b>(18,560)</b>	(15,890)	<b>(13,990)</b>	(10,180)	(11,330)	(7,060)
1.5 m (5 ft.)					<b>10 140</b>	6930	<b>7230</b>	4510	5170	3190
					<b>(21,880)</b>	(14,930)	<b>(15,650)</b>	(9,720)	(11,110)	(6,870)
Ground Line					<b>10 660</b>	6740	<b>7220</b>	4380	5100	3130
					<b>(23,090)</b>	(14,500)	<b>(15,520)</b>	(9,420)	(10,970)	(6,740)
-1.5 m (-5 ft.)			<b>9330</b>	<b>9330</b>	<b>10 330</b>	6720	<b>7180</b>	4340		
			<b>(21,390)</b>	<b>(21,390)</b>	<b>(22,390)</b>	(14,450)	<b>(15,430)</b>	(9,350)		
-3.0 m (-10 ft.)			<b>12 640</b>	<b>12 640</b>	<b>9150</b>	6820	<b>6580</b>	4420		
			<b>(27,400)</b>	<b>(27,400)</b>	<b>(19,750)</b>	(14,690)	<b>(14,030)</b>	(9,550)		
-4.5 m (-15 ft.)					<b>6300</b>	<b>6300</b>				
					<b>(13,030)</b>					
<i>With 2.91-m (9 ft. 7 in.) arm and 600-mm (24 in.) triple semi-grouser shoes</i>										
6.0 m (20 ft.)							<b>4650</b>	<b>4650</b>		
							<b>(10,210)</b>	<b>(10,210)</b>		
4.5 m (15 ft.)					<b>6030</b>	<b>6030</b>	<b>5200</b>	4870	<b>4820</b>	3300
					<b>(13,010)</b>	<b>(13,010)</b>	<b>(11,310)</b>	(10,480)	<b>(10,560)</b>	(7,070)
3.0 m (10 ft.)					<b>7950</b>	7310	<b>6070</b>	4630	5120	3200
					<b>(17,100)</b>	(15,750)	<b>(13,150)</b>	(9,980)	(11,000)	(6,870)
1.5 m (5 ft.)					<b>9680</b>	6810	<b>6940</b>	4400	4990	3080
					<b>(20,880)</b>	(14,670)	<b>(15,030)</b>	(9,470)	(10,730)	(6,630)
Ground Line			<b>4270</b>	<b>4270</b>	<b>10 540</b>	6540	<b>6980</b>	4230	4900	3000
			<b>(9,930)</b>	<b>(9,930)</b>	<b>(22,810)</b>	(14,080)	<b>(15,000)</b>	(9,110)	(10,540)	(6,450)
-1.5 m (-5 ft.)	<b>4900</b>	<b>4900</b>	<b>8520</b>	<b>8520</b>	<b>10 510</b>	6470	<b>6900</b>	4160	4870	2970
	<b>(11,010)</b>	<b>(11,010)</b>	<b>(19,440)</b>	<b>(19,440)</b>	<b>(22,760)</b>	(13,910)	<b>(14,830)</b>	(8,950)	(10,490)	(6,400)
-3.0 m (-10 ft.)	<b>9390</b>	<b>9390</b>	<b>13 810</b>	13 120	<b>9650</b>	6530	<b>6940</b>	4190		
	<b>(21,140)</b>	<b>(21,140)</b>	<b>(29,920)</b>	(28,090)	<b>(20,840)</b>	(14,050)	<b>(14,930)</b>	(9,040)		
-4.5 m (-15 ft.)			<b>10 680</b>	<b>10 680</b>	<b>7540</b>	6740				
			<b>(22,820)</b>	<b>(22,820)</b>	<b>(16,000)</b>	(14,540)				
<i>With 2.91-m (9 ft. 7 in.) arm and 700-mm (28 in.) triple semi-grouser shoes</i>										
6.0 m (20 ft.)							<b>4650</b>	<b>4650</b>		
							<b>(10,210)</b>	<b>(10,210)</b>		
4.5 m (15 ft.)					<b>6030</b>	<b>6030</b>	<b>5200</b>	4950	<b>4820</b>	3360
					<b>(13,010)</b>	<b>(13,010)</b>	<b>(11,310)</b>	(10,650)	<b>(10,560)</b>	(7,210)
3.0 m (10 ft.)					<b>7950</b>	7430	<b>6070</b>	4720	<b>5180</b>	3260
					<b>(17,100)</b>	(16,010)	<b>(13,150)</b>	(10,150)	(11,210)	(7,000)
1.5 m (5 ft.)					<b>9680</b>	6930	<b>6940</b>	4480	5090	3150
					<b>(20,880)</b>	(14,930)	<b>(15,030)</b>	(9,640)	(10,950)	(6,760)
Ground Line			<b>4270</b>	<b>4270</b>	<b>10 540</b>	6660	<b>7120</b>	4310	5000	3060
			<b>(9,930)</b>	<b>(9,930)</b>	<b>(22,810)</b>	(14,340)	<b>(15,300)</b>	(9,280)	(10,750)	(6,580)
-1.5 m (-5 ft.)	<b>4900</b>	<b>4900</b>	<b>8520</b>	<b>8520</b>	<b>10 510</b>	6590	<b>7040</b>	4240	4970	3030
	<b>(11,010)</b>	<b>(11,010)</b>	<b>(19,440)</b>	<b>(19,440)</b>	<b>(22,760)</b>	(14,170)	<b>(15,130)</b>	(9,130)	(10,700)	(6,530)
-3.0 m (-10 ft.)	<b>9390</b>	<b>9390</b>	<b>13 810</b>	13 340	<b>9650</b>	6650	<b>7010</b>	4280		
	<b>(21,140)</b>	<b>(21,140)</b>	<b>(29,920)</b>	(28,570)	<b>(20,840)</b>	(14,310)	<b>(15,070)</b>	(9,220)		
-4.5 m (-15 ft.)			<b>10 680</b>	<b>10 680</b>	<b>7540</b>	6860				
			<b>(22,820)</b>	<b>(22,820)</b>	<b>(16,000)</b>	(14,800)				



**210G LC Lift Capacities (continued)**

**Boldface type** indicates hydraulically limited capacity; lightface type indicates stability-limited capacities, in kg (lb.). Ratings at bucket lift hook; machine equipped with 666-kg (1,468 lb.) bucket, standard counterweight, and standard gauge; and situated on firm, level, uniform supporting surface. Total load includes weight of cables, hook, etc. Figures do not exceed 87 percent of hydraulic capacities or 75 percent of weight needed to tip machine. All lift capacities are based on ISO 10567 (with power boost).

LOAD POINT HEIGHT	HORIZONTAL DISTANCE FROM CENTERLINE OF ROTATION										
	1.5 m (5 ft.)		3.0 m (10 ft.)		4.5 m (15 ft.)		6.0 m (20 ft.)		7.5 m (25 ft.)		
	Over Front	Over Side	Over Front	Over Side	Over Front	Over Side	Over Front	Over Side	Over Front	Over Side	
With 2.91-m (9 ft. 7 in.) arm and 800-mm (32 in.) triple semi-grouser shoes											
6.0 m (20 ft.)								4650	4650		
								(10,210)	(10,210)		
4.5 m (15 ft.)					6030	6030	5200	5010	4820	3410	
					(13,010)	(13,010)	(11,310)	(10,790)	(10,560)	(7,310)	
3.0 m (10 ft.)					7950	7520	6070	4780	5180	3310	
					(17,100)	(16,200)	(13,150)	(10,290)	(11,290)	(7,100)	
1.5 m (5 ft.)					9680	7020	6940	4540	5170	3190	
					(20,880)	(15,120)	(15,030)	(9,780)	(11,110)	(6,860)	
Ground Line			4270	4270	10 540	6750	7220	4370	5080	3110	
			(9,930)	(9,930)	(22,810)	(14,530)	(15,520)	(9,410)	(10,920)	(6,680)	
-1.5 m (-5 ft.)	4900	4900	8520	8520	15 100	6680	7140	4300	5050	3080	
	(11,010)	(11,010)	(19,440)	(19,440)	(22,760)	(14,360)	(15,350)	(9,260)	(10,870)	(6,630)	
-3.0 m (-10 ft.)	9390	9390	13 810	13 510	9650	6740	7010	4340			
	(21,140)	(21,140)	(29,920)	(28,930)	(20,840)	(14,500)	(15,070)	(9,350)			
-4.5 m (-15 ft.)			10 680	10 680	7540	6950					
			(22,820)	(22,820)	(16,000)	(14,990)					

**Buckets 210G / 210G LC**

A full line of buckets is offered to meet a wide variety of applications. Digging forces are with power boost. Buckets are equipped with John Deere TK-Series Bucket Teeth standard. Replaceable cutting edges and a variety of teeth are available through John Deere Parts. Optional side cutters add 150 mm (6 in.) to bucket widths. Capacities are SAE heaped ratings.

Type Bucket	Bucket Width		Bucket Capacity		Bucket Weight		Bucket Dig Force		Arm Dig Force		Arm Dig Force		Bucket Tip Radius		Number of Teeth
	mm	in.	m <sup>3</sup>	cu. yd.	kg	lb.	kN	lbf	2.42 m (7 ft. 11 in.)	2.91 m (9 ft. 7 in.)	kN	lbf	mm	in.	
Heavy Duty	914	36	0.69	0.90	704	1,551	164.4	36,948	141.1	31,712	115.1	25,869	1422	56	5
	1067	42	0.83	1.09	768	1,692	164.4	36,948	141.1	31,712	115.1	25,869	1422	56	5
	1219	48	0.99	1.29	850	1,873	164.4	36,948	141.1	31,712	115.1	25,869	1422	56	6
Heavy Duty High Capacity	610	24	0.43	0.56	660	1,453	161.5	36,300	140.1	31,504	114.4	25,719	1448	57	4
	760	30	0.58	0.76	723	1,593	161.5	36,300	140.1	31,504	114.4	25,719	1448	57	4
	914	36	0.74	0.97	829	1,825	161.5	36,300	140.1	31,504	114.4	25,719	1448	57	5
	1067	42	0.91	1.19	924	2,035	161.5	36,300	140.1	31,504	114.4	25,719	1448	57	5

**Bucket Selection Guide\* 210G / 210G LC**

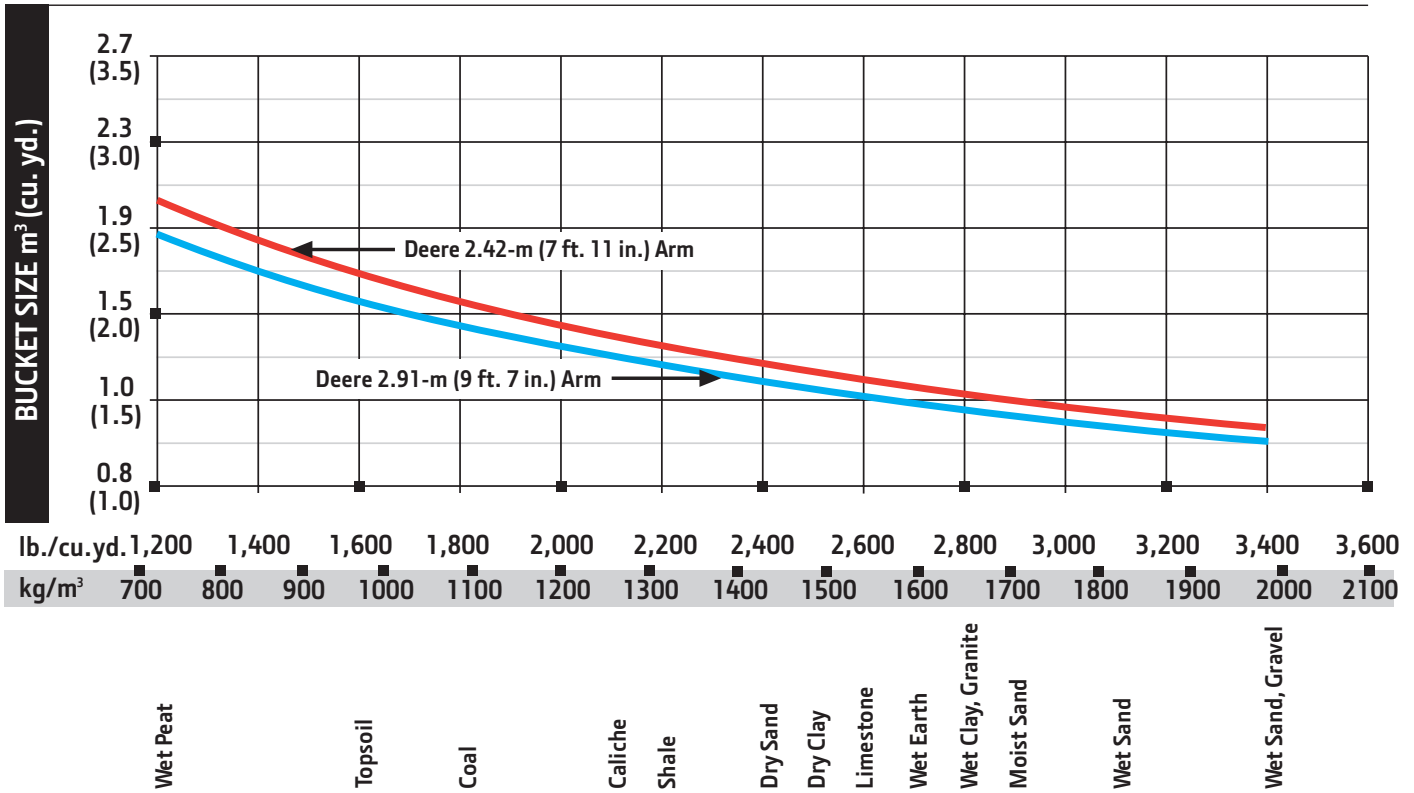

\* Contact your John Deere dealer for optimum bucket and attachment selections. These recommendations are for general conditions and average use. Does not include optional equipment such as thumbs or couplers. Larger buckets may be possible when using light materials, for flat and level operations, less compacted materials, and volume loading applications such as mass-excavation applications in ideal conditions. Smaller buckets are recommended for adverse conditions such as off-level applications, rocks, and uneven surfaces. Bucket capacity indicated is SAE heaped.

# Additional equipment

Key: ● Standard ▲ Optional or special

See your John Deere dealer for further information.

## 210G / 210G LC Engine

- Auto-idle system
- Automatic belt-tension device
- Batteries (2 – 12 volt)
- Coolant recovery tank
- Dual-element dry-type air filter
- Electronic engine control
- Enclosed fan guard (conforms to SAE J1308)
- Engine coolant to –37 deg. C (–34 deg. F)
- Fuel filter with water separator
- Full-flow oil filter
- Turbocharger with charge air cooler
- Cool-on-demand hydraulic-driven fan
- 500-hour engine-oil-change interval
- 70% (35 deg.) off-level capability
- Engine-oil-sampling valve
- Programmable auto shutdown
- ▲ Chrome exhaust stack
- ▲ Severe-duty fuel filter
- ▲ Hydraulic fan reverser
- ▲ Engine coolant heater

### Hydraulic System

- Reduced-drift valve for boom down, arm in
- Auxiliary hydraulic valve section
- Spring-applied, hydraulically released automatic swing brake
- Auxiliary hydraulic-flow adjustments through monitor
- Auto power lift
- 5,000-hour hydraulic-oil-change interval
- Hydraulic-oil-sampling valve
- ▲ Auxiliary hydraulic lines
- ▲ Auxiliary pilot and electric controls
- ▲ Hydraulic filter restriction indicator kit
- ▲ Load-lowering control device
- ▲ Single-pedal propel control
- ▲ Control pattern-change valve

### Undercarriage

- Planetary drive with axial piston motors
- Propel motor shields
- Spring-applied, hydraulically released automatic propel brake
- Track guides, front idler and center
- 2-speed propel with automatic shift
- Upper carrier rollers (2)
- Sealed and lubricated track chain
- ▲ Triple semi-grouser shoes, 600 mm (24 in.)
- ▲ Triple semi-grouser shoes, 700 mm (28 in.)
- ▲ Triple semi-grouser shoes, 800 mm (32 in.)

## 210G / 210G LC Upperstructure

- Right-hand, left-hand, and counterweight mirrors
- Vandal locks with ignition key: Cab door / Service doors / Toolbox
- Debris screen in side panel
- Remote-mounted engine oil and fuel filters
- Service handrails

### Front Attachments

- Centralized lubrication system
- Dirt seals on all bucket pins
- Less boom and arm
- Oil-impregnated bushings
- Reinforced resin thrust plates
- Tungsten carbide thermal coating on arm-to-bucket joint
- ▲ Arm, 2.42 m (7 ft. 11 in.)
- ▲ Arm, 2.91 m (9 ft. 7 in.)
- ▲ Attachment quick-couplers
- ▲ Boom cylinder with plumbing to mainframe for less boom and arm
- ▲ Buckets: Ditching / Heavy duty / Heavy-duty high capacity / Side cutters and teeth
- ▲ Material clamps
- ▲ Super-long fronts

### Operator's Station

- Meets ISO 12117-2 for ROPS
- Adjustable independent-control positions (levers-to-seat, seat-to-pedals)
- AM/FM radio
- Auto climate control/air conditioner/heater/pressurizer
- Built-in Operator's Manual storage compartment and manual
- Cell-phone power outlet, 12 volt, 60 watt, 5 amp
- Coat hook
- Deluxe suspension cloth seat with 100-mm (4 in.) adjustable armrests
- Floor mat
- Front windshield wiper with intermittent speeds
- Gauges (illuminated): Diesel Exhaust Fluid (DEF) / Engine coolant / Fuel
- Horn, electric
- Hour meter, electric
- Hydraulic shutoff lever, all controls
- Hydraulic warm-up control
- Interior light
- Large cup holder
- Machine Information Center (MIC)

## 210G / 210G LC Operator's Station (continued)

- Mode selectors (illuminated): Power modes (3) / Travel modes (2 with automatic shift) / Work mode (1)
- Multifunction, color LCD monitor with: Diagnostic capability / Multiple-language capabilities / Maintenance tracking / Clock / System monitoring with alarm features: Auto-idle indicator, engine air cleaner restriction indicator light, engine check, engine coolant temperature indicator light with audible alarm, engine oil pressure indicator light with audible alarm, low-alternator-charge indicator light, low-fuel indicator light, low DEF indication with audible alarm, fault code alert indicator, fuel-rate display, wiper-mode indicator, work-lights-on indicator, and work-mode indicator
- Motion alarm with cancel switch (conforms to SAE J994)
- Power-boost switch on right console lever
- Auxiliary hydraulic control switches in right console lever
- SAE 2-lever control pattern
- Seat belt, 51 mm (2 in.), retractable
- Tinted glass
- Transparent tinted overhead hatch
- Hot/cold beverage compartment
- ▲ Air-suspension heated seat
- ▲ Hydraulic oil filter restriction indicator light
- ▲ Protection screens for cab front, rear, and side
- ▲ Seat belt, 76 mm (3 in.), non-retractable
- ▲ Window vandal-protection covers

### Electrical

- 100-amp alternator
- Blade-type multi-fused circuits
- Positive-terminal battery covers
- JDLink™ wireless communication system (available in specific countries; see your dealer for details)
- ▲ Rearview camera
- ▲ Cab extension wiring harness

### Lights

- Work lights: Halogen / 1 mounted on boom / 1 mounted on frame
- ▲ 2 lights mounted on cab / 1 mounted on right side of boom / 1 mounted under engine hood

Net engine power is with standard equipment including air cleaner, exhaust system, alternator, and cooling fan, at test conditions specified per ISO 9249. No derating is required up to 3050-m (10,000 ft.) altitude. Specifications and design subject to change without notice. Wherever applicable, specifications are in accordance with SAE standards. Except where otherwise noted, these specifications are based on units with 1065-mm (42 in.), 0.91-m<sup>3</sup> (1.19 cu. yd.), 886-kg (1,951 lb.) general-purpose buckets; 2.91-m (9 ft. 7 in.) arms; 4250-kg (9,370 lb.) counterweights; 800-mm (32 in.) triple semi-grouser shoes; full fuel tanks; and 79-kg (175 lb.) operators.

