



JOHN DEERE

J

BACKHOES

310J | 310SJ | 310SJ TMC | 410J | 410J TMC | 710J



Smart choices.



310J

63 kW (84 hp)
6295-kg (13,880 lb.) operating weight
4.34-m (14 ft. 3 in.) backhoe digging depth
41.6-kN (9,350 lb.) loader breakout force
2996-kg (6,600 lb.) loader lift capacity

410J TMC

73 kW (98 hp)
8626-kg (19,022 lb.) operating weight
4.90-m (16 ft. 1 in.) backhoe digging depth
45.4-kN (10,210 lb.) loader breakout force
3332-kg (7,340 lb.) loader lift capacity

310SJ TMC

69 kW (93 hp)
8171-kg (18,017 lb.) operating weight
4.55-m (14 ft. 11 in.) backhoe digging depth
49.6-kN (11,160 lb.) loader breakout force
3368-kg (7,419 lb.) loader lift capacity

Whether you use them as a “shovel” or your main machine, there’s a J-Series Backhoe Loader to help you get it done. Loaded for bear or barely loaded, you’ll benefit from proven John Deere advantages such as attachment interchangeability, ground-level daily servicing, industry-low maintenance costs, smooth and responsive hydraulics, and unsurpassed

resale value. Enhancements such as an advanced multifunction diagnostic monitor, durable solid-state electronics, and improved cooling system make the J-Series even simpler to run and cheaper to keep. Plus, Total Machine Control (TMC) and tool carrier options raise the bar even higher, offering one-of-a-kind control and versatility.



310SJ

69 kW (93 hp)
 6580-kg (14,510 lb.) operating weight
 4.42-m (14 ft. 6 in.) backhoe digging depth
 49.6-kN (11,160 lb.) loader breakout force
 3368-kg (7,419 lb.) loader lift capacity

710J

94 kW (126 hp)
 10 431-kg (23,000 lb.) operating weight
 5.44-m (17 ft. 10 in.) backhoe digging depth
 69.1-kN (15,540 lb.) loader breakout force
 4212-kg (9,277 lb.) loader lift capacity

410J

73 kW (98 hp)
 6839-kg (15,080 lb.) operating weight
 4.83-m (15 ft. 10 in.) backhoe digging depth
 45.4-kN (10,210 lb.) loader breakout force
 3332-kg (7,340 lb.) loader lift capacity

Enhanced cooling package employs oil-to-water hydraulic and transmission coolers. Fewer stacked cores allow faster cold-weather warm-up, less plugging, and simplified cleanout.

Total Machine Control (TMC) option features industry-exclusive in-the-armrest joysticks for smooth fingertip control, exceptional fatigue-beating comfort, and enhanced productivity.

State-of-the-art multi-function monitor with easy-to-read messaging, large analog gauges, and LED warning lights gives vital operating info at a glance.

PowerTech™ wet-sleeve diesels deliver power without compromise and long-term durability.

Tool carrier with quick-coupler boasts increased lift capability and best-in-class work-tool visibility — plus set-and-forget parallel lift, return-to-carry, and boom height kick-out. It's available on either TMC machine.



Worksite Pro™ top-hook coupler allows quick and easy single-pin bucket changes. Accommodates 305-, 456-, and 610-mm (12, 18, and 24-in.) heavy-duty buckets.



Optional limited-slip mechanical-front-wheel drive delivers 80 percent of available power to the wheel with the best traction. Engage it “on the fly,” for true all-wheel drive when and where you need it.



Curved-knee loader-boom design enhances visibility and provides superior reach, easily dumping to the center of the truck. For fuller loads, faster.

Simply more productive.

Whether you're loading trucks, busting up blacktop, picking pipe, digging deep, or moving materials, J-Series Backhoes are more than up to it. Powerful and quick high-pressure hydraulics deliver generous breakout and lift capacity at both ends, along with impressive backhoe crowd power and swing torque. Excavator-style hydraulics smoothly blend functions,

so your operators won't have to work hard to be more productive. The standard PowerShift™ transmission is also easy to operate, offering smooth, on-the-go clutchless shifting. Delivers faster acceleration, higher transport speed, and better hill-climbing capability, too. No other backhoe lineup offers a similar combination of power, speed, and ability.



Extendable dipperstick adds digging depth, reach, and ability. Outer-box design grasps objects such as concrete slabs between the bucket and gripper teeth while extending or retracting. For easier loading into trucks.



J-Series Backhoes provide the swing-torque, boom, and dipperstick lift capacity needed to crane heavy objects.

All front and rear attachments are interchangeable with those from previous John Deere backhoes.

High-pressure hydraulics deliver smooth response, superior combined-function metering, and low-effort control regardless of the load or application.

Rearward-angled, box-constructed stabilizers and no-drift cylinders ensure rock-solid stability.



Do more without

Armrest-mounted controls enable TMC backhoes to be operated with the seat rotated up to 90 degrees from the rear position. For those times when you need to focus on the action beside you.

Choose the backhoe hydraulic speed you need. *Fast* for up to 20-percent quicker cycle times. *Medium* for normal digging. Or *slow* for craning objects, working in confined spaces, or excavating around existing utilities. Controls deliver the same low-effort, consistent response, regardless of hydraulic speed.

With auto-idle, momentarily releasing the joysticks slows engine speed, reducing fuel consumption and noise. Preset speed automatically resumes when a joystick is activated.

Backlit pushbuttons in the sealed switch module allow fingertip control of various functions such as return-to-dig.

Go from backhoe- to excavator-style controls at the push of a button. Adjusting hydraulic flow when changing attachments is also pushbutton easy.



lifting a finger.

Want maximum productivity with minimal effort? Add the TMC package to a 310SJ or 410J Backhoe. You'll enjoy intuitive, effortless fingertip control—and up to 20-percent faster cycle times. Joysticks respond easily to an operator's touch, for quicker, smoother control of loader and backhoe functions. Controls are conveniently located in the armrests, so you can even operate the backhoe while facing to the side. There's also a unique mini-joystick that lets you run both loader and backhoe simultaneously without removing your hands from the controls.

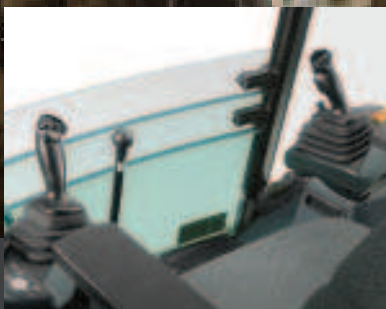

Fatigue-beating joysticks provide smooth, intuitive control of auxiliary loader attachments, extendable dipperstick, backhoe auxiliary attachments, hammer, MFWD, and horn.



Need to reposition quickly or get unstuck? Mini-joystick lets you run the loader and backhoe simultaneously without removing your hands from the joysticks or swiveling the seat.



Joystick switch provides fingertip control of hydraulic-powered attachments. Toggle on and off, or push and hold for momentary control. Armrest-mounted switches operate the stabilizers.



Parallel-lift that's simply unparalleled.

John Deere backhoes are already highly capable machines. Opt for a tool carrier on a TMC-equipped 310SJ or 410J and take versatility to an even higher level. With the most accurate leveling system available on a backhoe loader, you'll have all the finesse you need to get more done. Unlike mechanical loader linkages, exclusive

electrohydraulic parallel-lift employs fewer parts, so you'll spend less time on maintenance. And you won't have to worry about replacing current attachments, either. The quick-coupler lets you hook up to a variety of John Deere E- and G-Series as well as non-Deere loader attachments. For versatility without parallel, opt for a John Deere tool carrier.



One-of-a-kind electro-hydraulic design delivers unsurpassed capability. With true parallel-lift throughout the lift arc, it's perfect for a multitude of material-handling tasks.

Boom height kick-out sets maximum desired dump height, while return-to-carry and return-to-dig predetermine the lowered boom and bucket position. Helps speed production in repetitive loading applications.

Unlike traditional designs, John Deere's tool carrier eliminates the Z-bar linkage, self-leveling rod, and numerous grease zerks.



Low-profile loader knee is narrower through the line of sight, for a better view of the attachment. Visibility to the forks at truck-bed height is best in class.

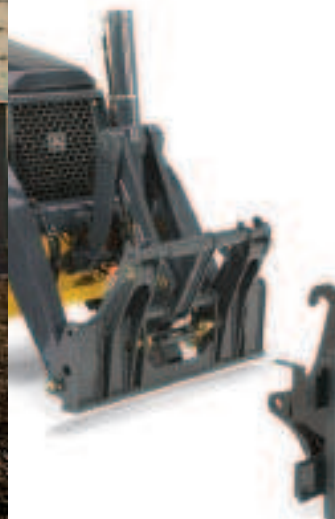

Worksite Pro™ quick-coupler lets you change attachments quickly and easily without leaving your seat. Accommodates a wide variety of attachments.



Backlit pushbuttons give convenient control of boom height kick-out, return-to-dig, and return-to-carry right from the seat.



Choose from joystick, pilot, two-lever, three-lever, four-lever, or SAE excavator-style controls. For smooth, combined-function metering. (Shown with pilot controls.)

Advanced monitor provides:

Vital and general operating information including hours, engine speed, and gear selection.

Industry-exclusive onboard diagnostics of most sensors and switches for quick troubleshooting.

Available machine security system prevents unauthorized machine movement. Requires pass code.

Ride-control option smooths moves over rough terrain, so full loads are more likely to arrive at their destination — instead of somewhere in-between. Reduces operator fatigue, too.

Comfortably ahead of the competition.

Who wouldn't be more productive in the spacious, well-equipped cab of a J-Series Backhoe? Its expansive, curved windshield provides a virtually unobstructed panoramic view of the work at hand and surrounding jobsite. An automatic high-velocity climate-control system and fully adjustable suspension seat ensure year-round comfort. The

state-of-the-art multifunction monitor with easy-to-read messaging, large analog gauges, and LED warning lights gives vital operating info at a glance. Add to these amenities such as an AM/FM radio, 12-volt power ports, and generous storage space for cups and other carry-ons, and it's easy to see why your operators will be more comfortably productive.

Standard PowerShift™ transmission allows no-clutch on-the-go shifting on all machines. It's an industry exclusive on the 310J.

Optional sound-suppression package significantly reduces noise levels and operator fatigue.

With convenient handholds, self-cleaning steps, and wide entryways, getting to work has never been easier. Separate service and park brake systems provide an extra measure of security.

No shortage of storage in here. There are cup holders, a place for a cell phone, and extra room for other carry-ons.

Need to extend your workday? Deluxe lighting package provides unsurpassed 360-degree illumination (optional on 310J).



TMC option (shown) includes a sculpted suspension seat with fully adjustable armrest-mounted joystick controls for all-day comfort. And near-effortless control.

Tilt steering wheel is infinitely adjustable. Angles up and out of the way for swiveling the seat or passing through the cab.

Highly efficient HVAC system with automotive-style directional vents helps keep the view clear and the cab comfortable.

You've got cruise control in your pickup — why not in your backhoes? Industry-exclusive rotary throttle lets you dial-in the speed you need. Engaging the brakes automatically drops engine speed to idle.

Auto-idle automatically reduces engine speed when hydraulics aren't in use. Reduces noise and preserves precious fuel.

12-volt power ports on both sides of the console provide convenient power for cell phones and other devices.



Totally welded mainframe resists torsional stress, absorbs shock loads, and delivers maximum strength. Simplifies service access to major components, too.

Powertrain components are isolated from shock-load stress and individually removable to help speed repairs and downtime.

Solid-state electrical system eliminates numerous relays and connectors for enhanced reliability.

Nothing lasts like a Deere.

Built with state-of-the-art tools and techniques by a quality-conscious workforce at our world-class facility in Dubuque, Iowa, J-Series Backhoes deliver unsurpassed reliability and uptime. Everything about these backhoes — from

their exceptionally durable one-piece, totally welded mainframe to their box-constructed loaders, booms, and dippersticks — is designed for maximum uptime. When you know how they're built, you'll run a John Deere.

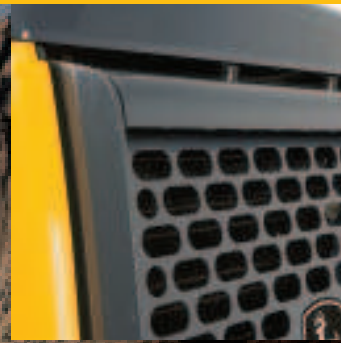

Engine hood is constructed of a resilient composite material that resists impacts and damage. Standard grille extensions further protect the front end.



No more stacked hydraulic and transmission coolers in front of the radiator. With improved airflow, fan speed has been reduced for less debris build-up and noise. Cleanout is easier, too.

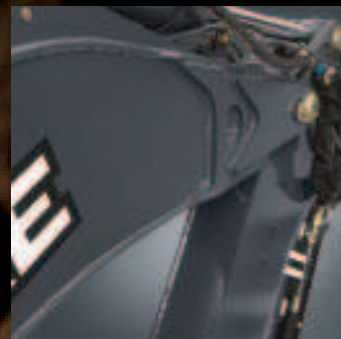

Backhoe boom, dipperstick, stabilizers, and loader are box-constructed of low-alloy steel for maximum strength.

Wet-sleeve liners provide uniform engine cooling and longer durability than cast-in-block designs.

Large pins and replaceable bushings deliver long-term durability, and keep the backhoe and loader tightly secured and digging true.

Sealed front axle and larger kingpins and differentials help ensure drivetrain durability.

Unlike axles that rely on internal augers to direct oil to critical components, Deere's design provides full-time, full-axle lubrication on any angle in any terrain.

Planetary final drives distribute loads over three gears and are sealed in a cooling oil bath for long life and trouble-free service.



Open wide and be awed.

500-hour engine and 2,000-hour hydraulic oil service intervals enable J-Series Backhoes to work longer between changes.

Wide-mouth fuel tank allows fast, ground-level fill-ups. Generous capacity lets you work longer before refueling.

Diagnostic test ports and available fluid-sample ports help speed preventative maintenance and troubleshooting.

Compare routine maintenance costs with other backhoes during their first 3,000 hours. You'll discover what owners already know—it costs less to run a Deere.

Your John Deere dealer has the parts and service you need to stay productive, and offers a wide variety of preventative maintenance and support programs to help control costs.

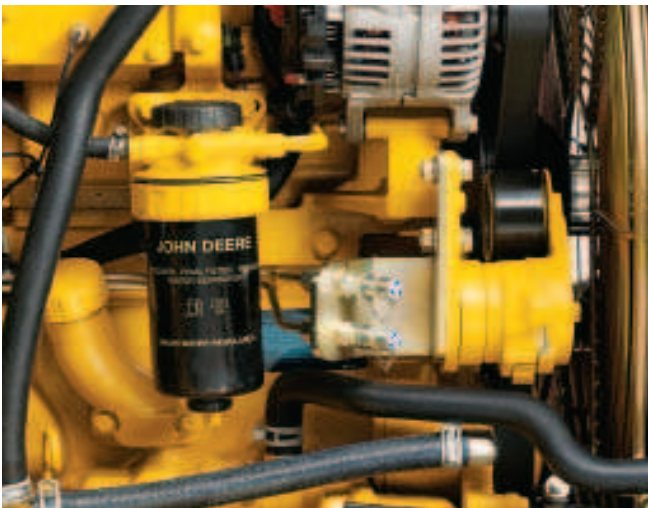

Vertical spin-on engine, transmission, and hydraulic filters and quick-release fuel filters allow quick, no-spill changes.



Convenient lube and periodic maintenance chart ensures that nothing gets overlooked. Synthetic bushings in the loader linkage and extendable dipperstick eliminate numerous grease zerks.

Tilt the hood and discover the many advantages that make J-Series Backhoes the simplest, least expensive to maintain. Same-side ground-level access to checkpoints makes quick work of the daily routine. Service intervals have been extended so you can work longer between changes. And because no maintenance beats low maintenance, self-adjusting serpentine belts, park brake, and wet-disc brakes seldom, if ever, require attention. With the John Deere J-Series, you'll spend less time and expense getting ready for work — and more time getting work done.



If something goes wrong, the monitor displays easy-to-understand diagnostic information to get you back up and running quickly.



Split floor mats and a large removable panel provide convenient, top-side access to internal components.

310J



Engine	310J	
	<i>For use in U.S., Canada, and Europe</i>	<i>For use outside U.S., Canada, and Europe</i>
Manufacturer and Model	John Deere PowerTech™ E 4045HT054 turbocharged, standard	John Deere PowerTech 4045T optional turbocharged
Non-Road Emissions Standard	EPA Tier 3/EU Stage IIIA	EPA Tier 2/EU Stage II
Displacement	4.5 L (276 cu. in.)	4.5 L (276 cu. in.)
Net Peak Power (ISO9249)	63 kW (84 hp) @ 2,000 rpm	59 kW (79 hp) @ 2,000 rpm
Net Peak Torque (ISO9249)	367 Nm (270 lb.-ft.) @ 1,300 rpm	340 Nm (250 lb.-ft.) @ 1,400 rpm
Net Torque Rise	47%	41%
Lubrication	pressure system with spin-on filter and cooler	pressure system with spin-on filter and cooler
Air Cleaner	dual-stage dry type with safety element and evacuator valve	dual-stage dry type with safety element and evacuator valve

Cooling	
Fan Type	suction
Engine Coolant Rating	-37 deg. C (-34 deg. F)
Engine Oil Cooler	oil to water

Powertrain			
Transmission	4-speed, helical-cut gears, full PowerShift™ with hydraulic reverser standard; electric clutch cutoff on loader lever		
Torque Converter	single stage, dual phase with 2.63:1 stall ratio; 280 mm (11 in.)		
Maximum Travel Speeds with Standard			
Engine	<i>Forward</i>	<i>Reverse</i>	
Gear 1	5.7 km/h (3.5 mph)	7.2 km/h (4.5 mph)	
Gear 2	10.4 km/h (6.5 mph)	13.2 km/h (8.2 mph)	
Gear 3	21.4 km/h (13.3 mph)	N/A	
Gear 4	35.9 km/h (22.3 mph)	N/A	
Axles			
Axle Oscillations, Stop to Stop (both axles)	22 deg.		
Axle Ratings	<i>Mechanical-front-wheel drive</i>		
	<i>Standard</i>	<i>Front</i>	<i>Rear</i>
Static	18 000 kg (39,683 lb.)	12 000 kg (26,455 lb.)	13 000 kg (28,660 lb.)
Dynamic	7200 kg (15,873 lb.)	6000 kg (13,228 lb.)	7000 kg (15,432 lb.)
Ultimate	32 950 kg (72,642 lb.)	28 200 kg (62,170 lb.)	30 600 kg (67,461 lb.)
Differentials	hydraulic locking rear, electric, foot actuated; open front		
Steering (ISO5010)	hydrostatic power and emergency steering		
Axle	<i>Mechanical-front-wheel drive</i>		
	<i>Non-powered front</i>		
Curb-Turning Radius			
With Brakes	3.58 m (11 ft. 9 in.)	3.44 m (11 ft. 4 in.)	
Without Brakes	4.08 m (13 ft. 5 in.)	3.94 m (12 ft. 11 in.)	
Bucket Clearance Circle			
With Brakes	10.11 m (33 ft. 2 in.)	9.89 m (32 ft. 5 in.)	
Without Brakes	11.05 m (36 ft. 3 in.)	10.76 m (35 ft. 4 in.)	
Steering Wheel Turns (lock to lock)	2.7	3.3	
Final Drive (mechanical-front wheel and rear axle)	heavy-duty, outboard planetary final drives distribute shock loads over 3 gears		
Brakes (conform to ISO 3450)			
Service	power assisted, hydraulic wet disc, mounted inboard, self-adjusting and self-equalizing		
Parking	spring-applied, hydraulically released, wet, multi disc, independent of service brakes with electric switch control		

Hydraulics 310J

Main Pump	open center, single gear
Pump Flow @ 2,200 rpm	
Backhoe	106 L/m (28 gpm)
Loader	106 L/m (28 gpm)
System Relief Pressure	
Backhoe	24 993 kPa (3,625 psi)
Loader	22 063 kPa (3,200 psi)
Bucket Dump at Maximum Height	1.3 sec.
Boom Lower (power down)	2.5 sec.
Backhoe Controls	two-lever manual standard; pilot controls with pattern select, three-lever manual controls with foot swing, and manual and/or electric auxiliary functions optional
Loader Controls	single-lever control with electric clutch cutoff switch standard; manual auxiliary function optional

Cylinders

Type	heat-treated, chrome-plated, polished rods; hardened-steel (replaceable bushings) pivot pins		
	<i>Bore</i>	<i>Rod Diameter</i>	<i>Stroke</i>
Loader Boom (2)	80 mm (3.15 in.)	50 mm (1.97 in.)	790 mm (31.10 in.)
Loader Bucket (1)	90 mm (3.54 in.)	50 mm (1.97 in.)	744 mm (29.29 in.)
Backhoe Boom (1)	110 mm (4.33 in.)	56 mm (2.20 in.)	821 mm (32.32 in.)
Backhoe Crowd (1)	110 mm (4.33 in.)	63 mm (2.48 in.)	553 mm (21.77 in.)
Backhoe Bucket (1)	80 mm (3.15 in.)	50 mm (1.97 in.)	892 mm (35.12 in.)
Backhoe Swing (2)	80 mm (3.15 in.)	45 mm (1.77 in.)	310 mm (12.20 in.)
Backhoe Extendable Dipperstick (1)	63 mm (2.48 in.)	32 mm (1.26 in.)	1062 mm (41.81 in.)
Backhoe Stabilizer (2)	80 mm (3.15 in.)	50 mm (1.97 in.)	500 mm (19.69 in.)
Non-Powered Axle (1)	70 mm (2.76 in.)	42 mm (1.65 in.)	213 mm (8.39 in.)
Mechanical-Front-Wheel Drive (1)	67 mm (2.64 in.)	42 mm (1.65 in.)	210 mm (8.27 in.)

Electrical

Voltage	12 volt
Alternator Rating	90 amp
Lights	4 halogen: 2 front and 2 rear (32,500 candlepower each); turn signals and flashers 2 front and 2 rear; stop and taillights and 2 rear reflectors

Operator Station

Type (SAE J1040)	canopy, isolation mounted, ROPS/FOPS, left/right access, with molded roof
------------------	---

Tires/Wheels

	<i>Front</i>	<i>Rear</i>
Non-Powered Front Axle	11L-16 SL F-3 (12)	19.5L-24 R-4 (10)
Mechanical-Front-Wheel Drive	12-16.5 NHS SS-1 (8)	19.5L-24 R-4 (10)

Serviceability

Hydraulic Oil Filter, Spin-On Enclosed Replaceable Element, Vertically Mounted	6-micron filtration / 1,000 service hours
Refill Capacities	
Cooling System	25 L (26 qt.)
Rear Axle	18 L (19 qt.)
Engine Oil (including vertical spin-on filter)	13 L (14 qt.)
Torque Converter and Transmission	15 L (16 qt.)
Fuel Tank (with ground-level fueling)	155 L (41 gal.)
Hydraulic System	91 L (24 gal.)
Hydraulic Reservoir	39 L (10.2 gal.)
Mechanical-Front-Wheel-Drive Housing	
Axle	6.5 L (7 qt.)
Planetary (each)	1 L (1 qt.)

Operating Weights

With Full Fuel Tank, 79-kg (175 lb.) Operator, and Standard Equipment	6295 kg (13,880 lb.)
Typical with Cab, Mechanical-Front-Wheel Drive, Extendable Dipperstick, and 454-kg (1,000 lb.) Counterweight	7356 kg (16,220 lb.)
Optional Components	
Cab	263 kg (580 lb.)
Mechanical-Front-Wheel Drive with Tires	168 kg (370 lb.)
Extendable Dipperstick	200 kg (440 lb.)
Front Loader Coupler	286 kg (630 lb.)
Backhoe Bucket Coupler	59 kg (130 lb.)

Overall Dimensions 310J

- A** Ground Clearance (minimum) 305 mm (12 in.)
- B** Overall Length (transport) 7.09 m (23 ft. 3 in.)
- C** Width over Tires 2.18 m (7 ft. 2 in.)
- D** Height to Top of ROPS/Cab 2.74 m (9 ft. 0 in.)
- E** Length from Axle to Axle
 - Non-Powered Front Axle 2.11 m (6 ft. 11 in.)
 - Mechanical-Front-Wheel-Drive Axle 2.14 m (7 ft. 0 in.)

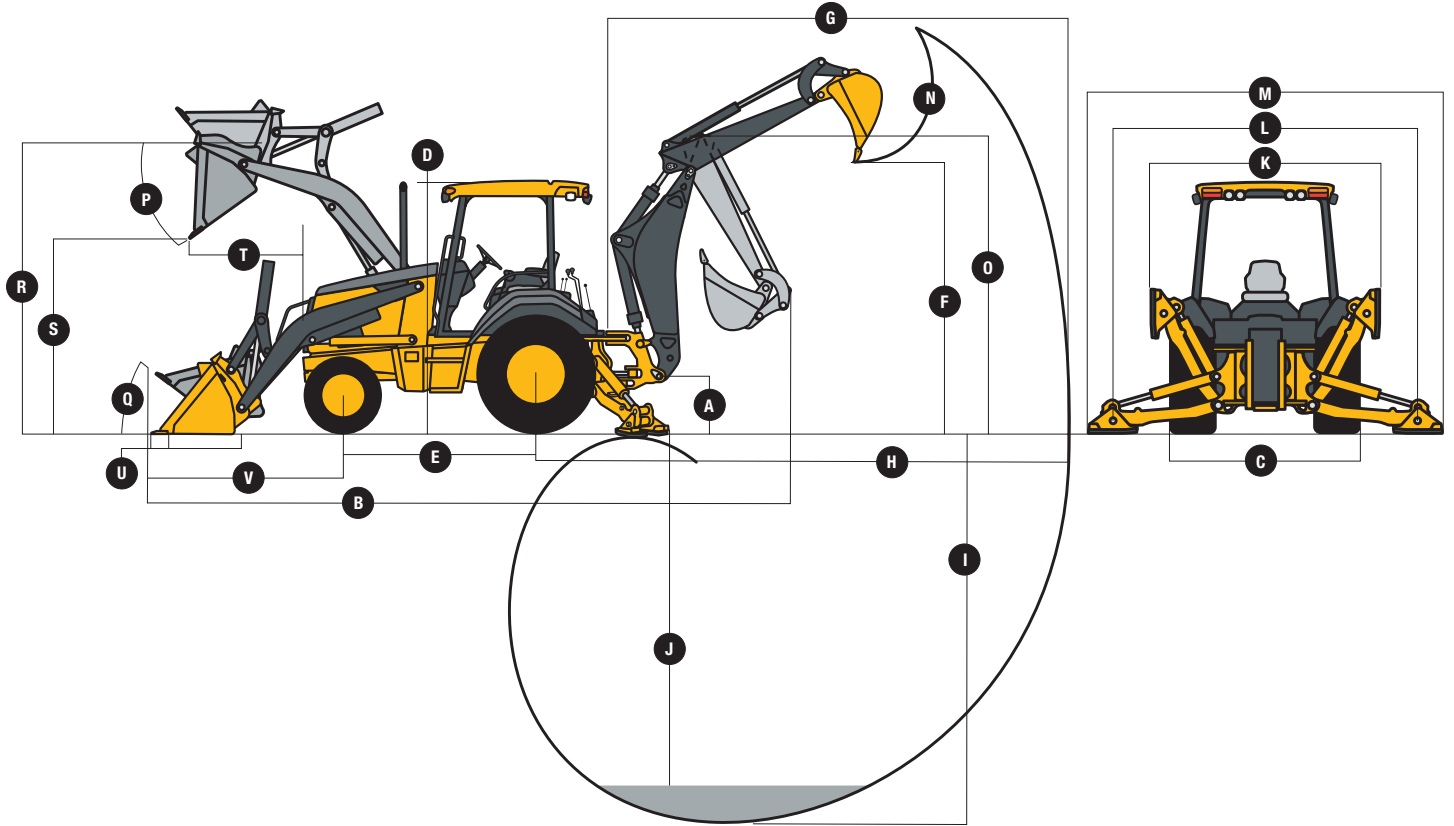

Backhoe Dimensions / Performance 310J

Backhoe specifications are with 610-mm x 0.18-m³ (24 in. x 6.5 cu. ft.) bucket

- Bucket Range 305–762 mm (12–30 in.)
- Digging Force
 - Bucket Cylinder 49.4 kN (11,106 lb.)
 - Crowd Cylinder 31.2 kN (7,006 lb.)
- Swing Arc 180 deg.
- Operator Control two levers
- Leveling Angle 14 deg.
- Stabilizer Angle Rearward 18 deg.

	<i>With Standard Backhoe</i>	<i>With Optional Extendable Dipperstick Retracted</i>	<i>Extended</i>
F Loading Height (truck loading position)	3.33 m (10 ft. 11 in.)	3.38 m (11 ft. 1 in.)	4.24 m (13 ft. 11 in.)
G Reach from Center of Swing Pivot	5.44 m (17 ft. 10 in.)	5.51 m (18 ft. 1 in.)	6.53 m (21 ft. 5 in.)
H Reach from Center of Rear Axle	6.50 m (21 ft. 4 in.)	6.58 m (21 ft. 7 in.)	7.59 m (24 ft. 11 in.)
I Digging Depth (SAE maximum)	4.34 m (14 ft. 3 in.)	4.39 m (14 ft. 5 in.)	5.46 m (17 ft. 11 in.)
J Digging Depth (SAE)			
610-mm (2 ft.) Flat Bottom	4.32 m (14 ft. 2 in.)	4.37 m (14 ft. 4 in.)	5.44 m (17 ft. 10 in.)
2440-mm (8 ft.) Flat Bottom	3.96 m (13 ft. 0 in.)	4.06 m (13 ft. 4 in.)	5.18 m (17 ft. 0 in.)
K Stabilizer Width (transport)	2.18 m (7 ft. 2 in.)	2.18 m (7 ft. 2 in.)	2.18 m (7 ft. 2 in.)
L Stabilizer Spread (operating)	3.10 m (10 ft. 2 in.)	3.10 m (10 ft. 2 in.)	3.10 m (10 ft. 2 in.)
M Stabilizer Overall Width (operating)	3.53 m (11 ft. 7 in.)	3.53 m (11 ft. 7 in.)	3.53 m (11 ft. 7 in.)
N Bucket Rotation	190 deg.	190 deg.	190 deg.
O Transport Height	3.43 m (11 ft. 3 in.)	3.40 m (11 ft. 2 in.)	3.40 m (11 ft. 2 in.)

Loader Dimensions / Performance

310J

P Bucket Dump Angle (maximum)	45 deg.				
Q Rollback Angle at Ground Level	40 deg.				
	<i>Heavy-duty</i>	<i>Heavy-duty</i>	<i>Heavy-duty long lip</i>	<i>Multipurpose</i>	<i>Multipurpose</i>
Bucket Capacity	0.77 m ³ (1.00 cu. yd.)	0.86 m ³ (1.12 cu. yd.)	0.96 m ³ (1.25 cu. yd.)	0.77 m ³ (1.00 cu. yd.)	0.96 m ³ (1.25 cu. yd.)
Width	2184 mm (86 in.)	2184 mm (86 in.)	2184 mm (86 in.)	2083 mm (82 in.)	2184 mm (86 in.)
Weight	363 kg (800 lb.)	390 kg (860 lb.)	405 kg (892 lb.)	771 kg (1,699 lb.)	795 kg (1,750 lb.)
Breakout Force	41.6 kN (9,350 lb.)	42.3 kN (9,500 lb.)	39.9 kN (8,975 lb.)	37.3 kN (8,375 lb.)	36.4 kN (8,175 lb.)
Lift Capacity (full height)	2996 kg (6,600 lb.)	3076 kg (6,775 lb.)	2849 kg (6,275 lb.)	2554 kg (5,625 lb.)	3757 kg (8,275 lb.)
R Height to Bucket Hinge Pin (maximum)	3.38 m (11 ft. 1 in.)	3.38 m (11 ft. 1 in.)	3.38 m (11 ft. 1 in.)	3.38 m (11 ft. 1 in.)	3.38 m (11 ft. 1 in.)
S Dump Clearance (bucket at 45 deg.)	2.69 m (8 ft. 10 in.)	2.69 m (8 ft. 10 in.)	2.48 m (8 ft. 2 in.)	2.59 m (8 ft. 6 in.)	2.59 m (8 ft. 6 in.)
T Reach at Full Height (bucket at 45 deg.)	785 mm (30.9 in.)	767 mm (30.2 in.)	809 mm (31.9 in.)	818 mm (32.2 in.)	818 mm (32.2 in.)
U Digging Depth Below Ground (bucket level)	160 mm (6.3 in.)	175 mm (6.9 in.)	147 mm (5.8 in.)	197 mm (7.8 in.)	197 mm (7.8 in.)
V Length From Front Axle Centerline to Bucket Cutting Edge	2.03 m (6 ft. 8 in.)	2.03 m (6 ft. 8 in.)	2.18 m (7 ft. 2 in.)	2.15 m (7 ft. 1 in.)	2.20 m (7 ft. 3 in.)

Lift Capacity with Quick-Coupler / Forks

Hydraulic Capacity	1219-mm (48 in.) tines	1524-mm (60 in.) tines
A' Maximum Height	1746 kg (3,850 lb.)	1556 kg (3,430 lb.)
B' Maximum Reach	2688 kg (5,925 lb.)	2467 kg (5,438 lb.)
C' At Ground Line	3493 kg (7,700 lb.)	3269 kg (7,207 lb.)
D' Below Ground Line	262 mm (10.3 in.)	262 mm (10.3 in.)

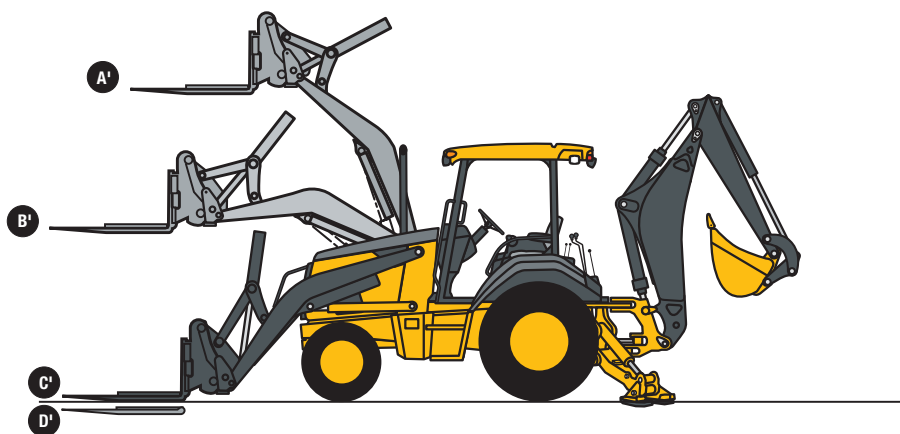

Lift capacities are over-end values in kg (lb.) according to SAE J31. Figures listed are 87% of the maximum lift force available. Base vehicle includes counterweight.

310J Backhoe with Standard Dipperstick

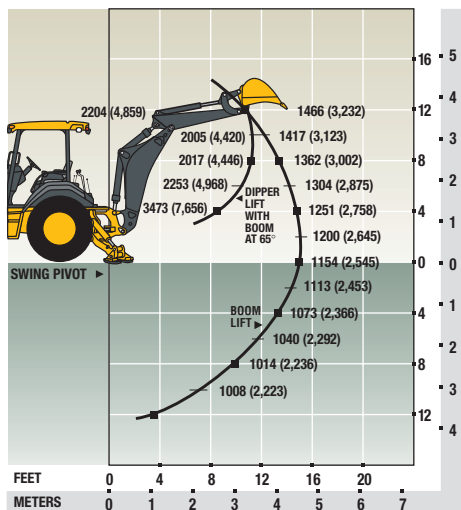

310J Backhoe with 1.07-m (3 ft. 6 in.) Extendable Dipperstick, Retracted

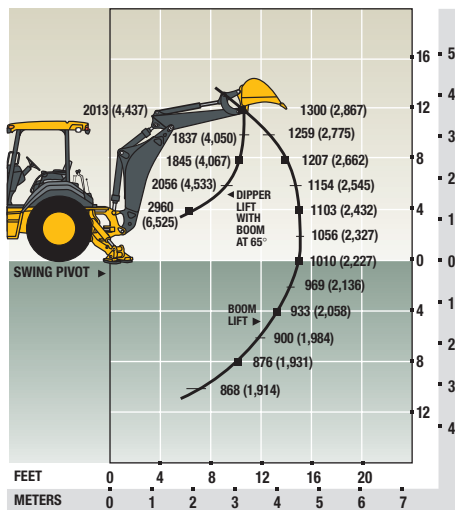

310J Backhoe with 1.07-m (3 ft. 6 in.) Extendable Dipperstick, Extended

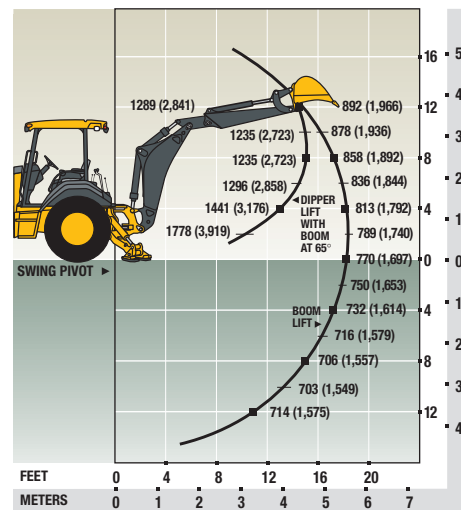

For more detailed spec information and available options, log on to www.JohnDeere.com.

310SJ



Engine

310SJ

	<i>For use in U.S., Canada, and Europe</i>	<i>For use outside U.S., Canada, and Europe</i>
Manufacturer and Model	John Deere PowerTech™ E 4045HT054 turbocharged, standard	John Deere PowerTech 4045T turbocharged, standard*
Non-Road Emissions Standard	EPA Tier 3/EU Stage IIIA	EPA Tier 2/EU Stage II
Displacement	4.5 L (276 cu. in.)	4.5 L (276 cu. in.)
Net Peak Power (ISO9249)	69 kW (93 hp) @ 2,000 rpm	69 kW (92 hp) @ 2,000 rpm
Net Peak Torque (ISO9249)	392 Nm (288 lb.-ft.) @ 1,300 rpm	384 Nm (282 lb.-ft.) @ 1,400 rpm
Net Torque Rise	47%	46%
Lubrication	pressure system with spin-on filter and cooler	pressure system with spin-on filter and cooler
Air Cleaner	dual-stage dry type with safety element and evacuator valve	dual-stage dry type with safety element and evacuator valve

*This engine not available on 310SJ TMC.

Cooling

Fan Type	suction
Engine Coolant Rating	-37 deg. C (-34 deg. F)
Engine Oil Cooler	oil to water

Powertrain

Transmission 4-speed, helical-cut gears, full PowerShift™ with hydraulic reverser standard; electric clutch cutoff on loader lever

Torque Converter single stage, dual phase with 2.63:1 stall ratio; 280 mm (11 in.)

Maximum Travel Speeds with Standard

Engine	<i>Forward</i>	<i>Reverse</i>
Gear 1	5.7 km/h (3.5 mph)	7.2 km/h (4.5 mph)
Gear 2	10.4 km/h (6.5 mph)	13.1 km/h (8.1 mph)
Gear 3	21.4 km/h (13.3 mph)	21.1 km/h (13.1 mph)
Gear 4	36.2 km/h (22.5 mph)	N/A

Axles

Axle Oscillations, Stop to Stop (both axles) 22 deg.

Axle Ratings	<i>Mechanical-</i>		
	<i>Standard</i>	<i>front-wheel drive</i>	<i>Rear</i>
Static	18 000 kg (39,683 lb.)	12 000 kg (26,455 lb.)	13 000 kg (28,660 lb.)
Dynamic	7200 kg (15,873 lb.)	6000 kg (13,228 lb.)	7000 kg (15,432 lb.)
Ultimate	32 950 kg (72,642 lb.)	28 200 kg (62,170 lb.)	30 600 kg (67,461 lb.)

Differentials hydraulic locking rear, electric, foot actuated; limited slip front

Steering (ISO5010) hydrostatic power and emergency steering

Axle	<i>Mechanical-</i>	
	<i>front-wheel drive</i>	<i>Non-powered front</i>
Curb-Turning Radius		
With Brakes	3.58 m (11 ft. 9 in.)	3.44 m (11 ft. 4 in.)
Without Brakes	4.08 m (13 ft. 5 in.)	3.94 m (12 ft. 11 in.)
Bucket Clearance Circle		
With Brakes	10.11 m (33 ft. 2 in.)	9.89 m (32 ft. 5 in.)
Without Brakes	11.05 m (36 ft. 3 in.)	10.76 m (35 ft. 4 in.)
Steering Wheel Turns (lock to lock)	2.7	3.3

Final Drive (mechanical-front wheel and

rear axle) heavy-duty, outboard planetary final drives distribute shock loads over 3 gears

Brakes (conform to ISO 3450)

Service	power assisted, hydraulic wet disc, mounted inboard, self-adjusting and self-equalizing
Parking	spring-applied, hydraulically released, wet, multi disc, independent of service brakes with electric switch control

Hydraulics 310SJ

Main Pump	open center, gear type, tandem with unloader
Pump Flow @ 2,200 rpm	
Backhoe	136 L/m (36 gpm)
Loader	106 L/m (28 gpm)
System Relief Pressure	
Backhoe	24 993 kPa (3,625 psi)
Loader	24 993 kPa (3,625 psi)
Backhoe Controls	two-lever manual standard; pilot controls with pattern select, three-lever manual controls with foot swing, and manual and/or electric auxiliary functions optional
Loader Controls	single-lever control with electric clutch cutoff switch standard; manual auxiliary function optional

Cylinders

Type	heat-treated, chrome-plated, polished rods; hardened-steel (replaceable bushings) pivot pins		
	<i>Bore</i>	<i>Rod Diameter</i>	<i>Stroke</i>
Loader Boom (2)	80 mm (3.15 in.)	50 mm (1.97 in.)	790 mm (31.10 in.)
Loader Bucket (1)	90 mm (3.54 in.)	50 mm (1.97 in.)	744 mm (29.29 in.)
Backhoe Boom (1)	120 mm (4.72 in.)	56 mm (2.20 in.)	795 mm (31.30 in.)
Backhoe Crowd (1)	115 mm (4.53 in.)	63 mm (2.48 in.)	603 mm (23.72 in.)
Backhoe Bucket (1)	90 mm (3.54 in.)	56 mm (2.20 in.)	810 mm (31.89 in.)
Heavy-Duty Option (1)	100 mm (3.94 in.)	63 mm (2.48 in.)	810 mm (31.89 in.)
Backhoe Swing (2)	90 mm (3.54 in.)	50 mm (1.97 in.)	278 mm (10.94 in.)
Backhoe Extendable Dipperstick (1)	70 mm (2.76 in.)	40 mm (1.57 in.)	1067 mm (42.01 in.)
Backhoe Stabilizer			
Standard (2)	90 mm (3.54 in.)	50 mm (1.97 in.)	500 mm (19.69 in.)
Longer Optional (2)	100 mm (3.94 in.)	50 mm (1.97 in.)	500 mm (19.69 in.)
Non-Powered Axle (1)	70 mm (2.76 in.)	42 mm (1.65 in.)	213 mm (8.39 in.)
Mechanical-Front-Wheel Drive (1)	67 mm (2.64 in.)	42 mm (1.65 in.)	210 mm (8.27 in.)

Electrical

Voltage	12 volt
Alternator Rating	90 amp
Lights	4 halogen: 2 front and 2 rear (32,500 candlepower each); turn signals and flashers 2 front and 2 rear; stop and taillights and 2 rear reflectors

Operator Station

Type (SAE J1040)	canopy, isolation mounted, ROPS/FOPS, left/right access, with molded roof
------------------	---

Tires/Wheels

	<i>Front</i>	<i>Rear</i>
Non-Powered Front Axle	11L-16 SL F-3 (12)	19.5L-24 R-4 (10)
Mechanical-Front-Wheel Drive	12.5/80-18 I-3 (10) 340/80R18 XMCL	19.5L-24 R-4 (10) 500/70R24 XMCL

Serviceability

Hydraulic Oil Filter, Spin-On Enclosed Replaceable Element, Vertically Mounted	6-micron filtration / 1,000 service hours
--	---

Refill Capacities

Cooling System	25 L (26 qt.)
Rear Axle	18 L (19 qt.)
Engine Oil (including vertical spin-on filter)	13 L (14 qt.)
Torque Converter and Transmission	15 L (16 qt.)
Fuel Tank (with ground-level fueling)	155 L (41 gal.)
Hydraulic System	91 L (24 gal.)
Hydraulic Reservoir	39 L (10.2 gal.)
Mechanical-Front-Wheel-Drive Housing	
Axle	6.5 L (7 qt.)
Planetary (each)	1 L (1 qt.)

Operating Weights

With Full Fuel Tank, 79-kg (175 lb.) Operator, and Standard Equipment	6580 kg (14,510 lb.)
Typical with Cab, Mechanical-Front-Wheel Drive, Extendable Dipperstick, and 454-kg (1,000 lb.) Counterweight	7728 kg (17,040 lb.)

Optional Components

Cab	263 kg (580 lb.)
Mechanical-Front-Wheel Drive with Tires	220 kg (485 lb.)
Extendable Dipperstick	222 kg (490 lb.)
Front Loader Coupler	286 kg (630 lb.)
Backhoe Bucket Coupler	63 kg (138 lb.)

Overall Dimensions 310SJ

- A** Ground Clearance (minimum) 330 mm (13 in.)
- B** Overall Length (transport) 7.16 m (23 ft. 6 in.)
- C** Width over Tires 2.18 m (7 ft. 2 in.)
- D** Height to Top of ROPS/Cab 2.79 m (9 ft. 2 in.)
- E** Length from Axle to Axle
 - Non-Powered Front Axle 2.11 m (6 ft. 11 in.)
 - Mechanical-Front-Wheel-Drive Axle 2.14 m (7 ft. 0 in.)

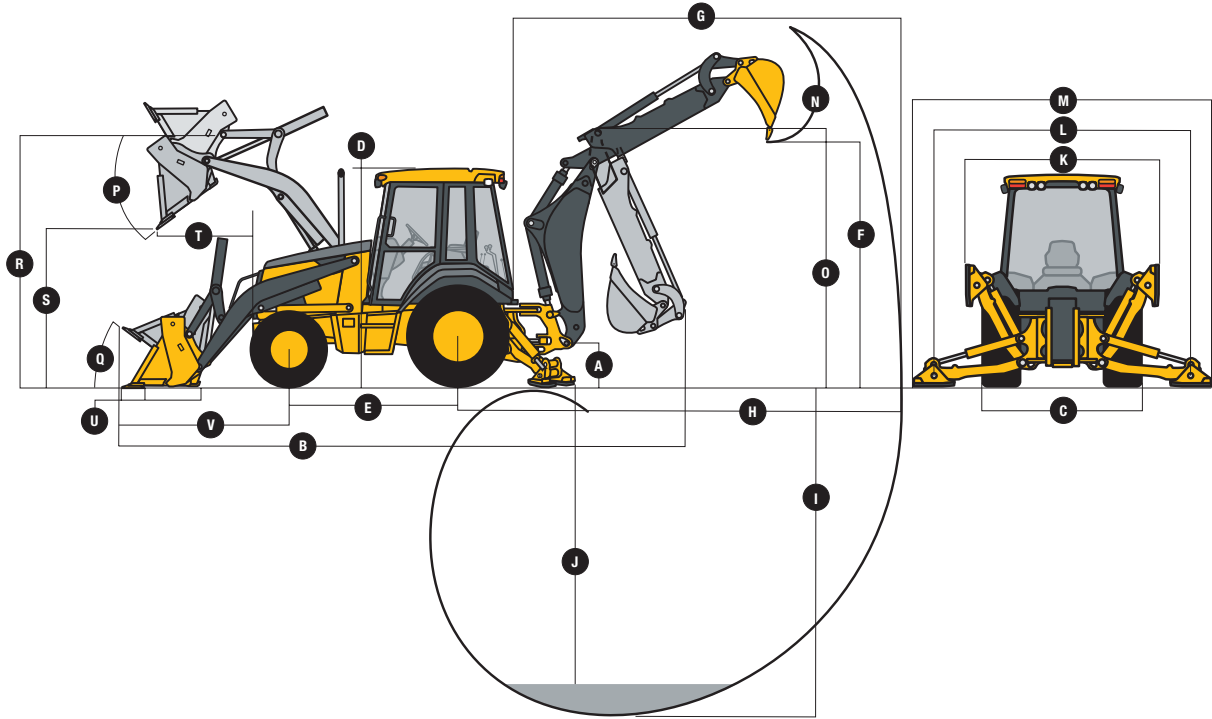

Backhoe Dimensions / Performance 310SJ

Backhoe specifications are with 610-mm x 0.21-m³ (24 in. x 7.5 cu. ft.) bucket

- Bucket Range 305–762 mm (12–30 in.)
- Digging Force
 - Bucket Cylinder 53.3 kN (11,990 lb.)
 - With Heavy-Duty Cylinder Option 67.8 kN (15,236 lb.)
 - Crowd Cylinder 36.0 kN (8,090 lb.)
- Swing Arc 180 deg.
- Operator Control two levers

	<i>With Standard Backhoe</i>	<i>With Optional Extendable Dipperstick</i>	
		<i>Retracted</i>	<i>Extended</i>
F Loading Height (truck loading position)	3.43 m (11 ft. 3 in.)	3.43 m (11 ft. 3 in.)	4.29 m (14 ft. 1 in.)
G Reach from Center of Swing Pivot	5.56 m (18 ft. 3 in.)	5.66 m (18 ft. 7 in.)	6.68 m (21 ft. 11 in.)
H Reach from Center of Rear Axle	6.63 m (21 ft. 9 in.)	6.73 m (22 ft. 1 in.)	7.72 m (25 ft. 4 in.)
I Digging Depth (SAE maximum)	4.42 m (14 ft. 6 in.)	4.55 m (14 ft. 11 in.)	5.61 m (18 ft. 5 in.)
J Digging Depth (SAE)			
610-mm (2 ft.) Flat Bottom	4.37 m (14 ft. 4 in.)	4.50 m (14 ft. 9 in.)	5.56 m (18 ft. 3 in.)
2440-mm (8 ft.) Flat Bottom	4.06 m (13 ft. 4 in.)	4.19 m (13 ft. 9 in.)	5.33 m (17 ft. 6 in.)
K Stabilizer Width (transport)	2.18 m (7 ft. 2 in.)	2.18 m (7 ft. 2 in.)	2.18 m (7 ft. 2 in.)
L Stabilizer Spread (operating)			
Standard Stabilizers	3.10 m (10 ft. 2 in.)	3.10 m (10 ft. 2 in.)	3.10 m (10 ft. 2 in.)
Long Stabilizers	3.45 m (11 ft. 4 in.)	3.45 m (11 ft. 4 in.)	3.45 m (11 ft. 4 in.)
M Stabilizer Overall Width (operating)			
Standard Stabilizers	3.53 m (11 ft. 7 in.)	3.53 m (11 ft. 7 in.)	3.53 m (11 ft. 7 in.)
Long Stabilizers	4.03 m (13 ft. 3 in.)	4.03 m (13 ft. 3 in.)	4.03 m (13 ft. 3 in.)
N Bucket Rotation	190 deg.	190 deg.	190 deg.
O Transport Height	3.51 m (11 ft. 6 in.)	3.48 m (11 ft. 5 in.)	3.48 m (11 ft. 5 in.)

Loader Dimensions / Performance

310SJ

P Bucket Dump Angle (maximum)	45 deg.					
Q Rollback Angle at Ground Level	40 deg.					
Bucket Capacity	<i>Heavy-duty</i>	<i>Heavy-duty</i>	<i>Heavy-duty long lip</i>	<i>Heavy-duty</i>	<i>Multipurpose</i>	<i>Multipurpose</i>
	0.77 m ³ (1.00 cu. yd.)	0.86 m ³ (1.12 cu. yd.)	0.96 m ³ (1.25 cu. yd.)	1.00 m ³ (1.31 cu. yd.)	0.96 m ³ (1.25 cu. yd.)	1.00 m ³ (1.31 cu. yd.)
Width	2184 mm (86 in.)	2184 mm (86 in.)	2184 mm (86 in.)	2337 mm (92 in.)	2184 mm (86 in.)	2337 mm (92 in.)
Weight	363 kg (800 lb.)	390 kg (860 lb.)	405 kg (892 lb.)	521 kg (1,148 lb.)	795 kg (1,750 lb.)	817 kg (1,800 lb.)
Breakout Force	49.6 kN (11,160 lb.)	49.2 kN (11,051 lb.)	45.4 kN (10,210 lb.)	45.8 kN (10,300 lb.)	43.1 kN (9,700 lb.)	42.9 kN (9,650 lb.)
Lift Capacity (full height)	3368 kg (7,419 lb.)	3338 kg (7,353 lb.)	3332 kg (7,340 lb.)	3269 kg (7,200 lb.)	3042 kg (6,700 lb.)	2996 kg (6,600 lb.)
R Height to Bucket Hinge Pin (maximum)	3.40 m (11 ft. 2 in.)	3.40 m (11 ft. 2 in.)	3.40 m (11 ft. 2 in.)	3.40 m (11 ft. 2 in.)	3.40 m (11 ft. 2 in.)	3.40 m (11 ft. 2 in.)
S Dump Clearance (bucket at 45 deg.)	2.69 m (8 ft. 10 in.)	2.69 m (8 ft. 10 in.)	2.48 m (8 ft. 2 in.)	2.64 m (8 ft. 8 in.)	2.62 m (8 ft. 7 in.)	2.62 m (8 ft. 7 in.)
T Reach at Full Height (bucket at 45 deg.)	785 mm (30.9 in.)	767 mm (30.2 in.)	911 mm (35.9 in.)	765 mm (30.1 in.)	818 mm (32.2 in.)	818 mm (32.2 in.)
U Digging Depth Below Ground (bucket level)	160 mm (6.3 in.)	175 mm (6.9 in.)	147 mm (5.8 in.)	206 mm (8.1 in.)	185 mm (7.3 in.)	185 mm (7.3 in.)
V Length From Front Axle Centerline to	Bucket Cutting Edge	2.03 m (6 ft. 8 in.)	2.03 m (6 ft. 8 in.)	2.18 m (7 ft. 2 in.)	2.03 m (6 ft. 8 in.)	2.15 m (7 ft. 1 in.)

Lift Capacity with Quick-Coupler / Forks

Hydraulic Capacity	1219-mm (48 in.) tines	1524-mm (60 in.) tines
A' Maximum Height	2073 kg (4,570 lb.)	1891 kg (4,170 lb.)
B' Maximum Reach	3162 kg (6,971 lb.)	3003 kg (6,621 lb.)
C' At Ground Line	4145 kg (9,138 lb.)	3883 kg (8,561 lb.)
D' Below Ground Line	211 mm (8.3 in.)	211 mm (8.3 in.)

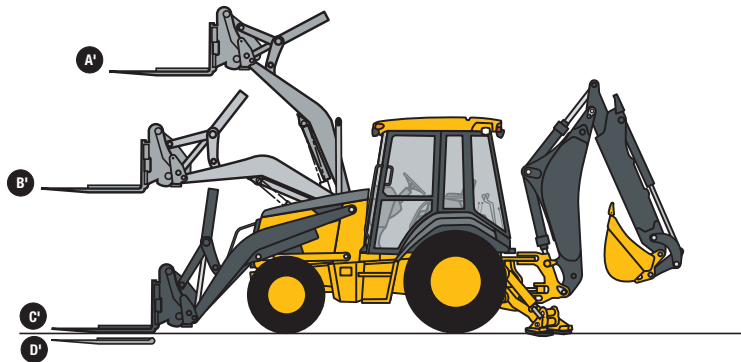

Lift capacities are over-end values in kg (lb.) according to SAE J31. Figures listed are 87% of the maximum lift force available. Base vehicle includes counterweight.

310SJ Backhoe with Standard Dipperstick

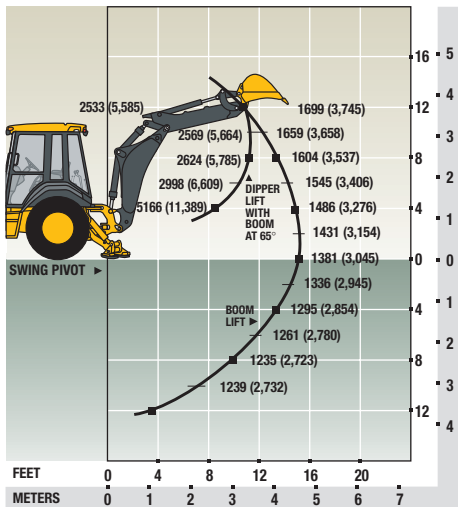

310SJ Backhoe with 1.07-m (3 ft. 6 in.) Extendable Dipperstick, Retracted

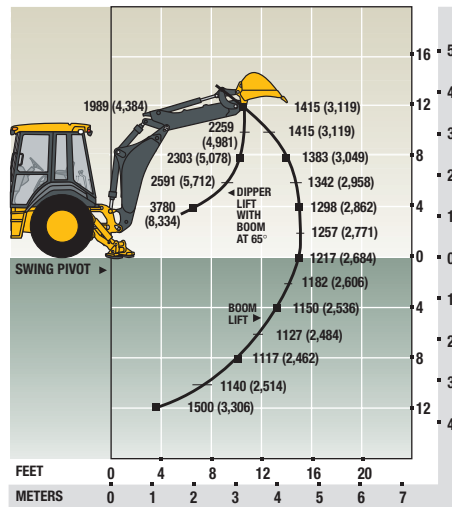

310SJ Backhoe with 1.07-m (3 ft. 6 in.) Extendable Dipperstick, Extended

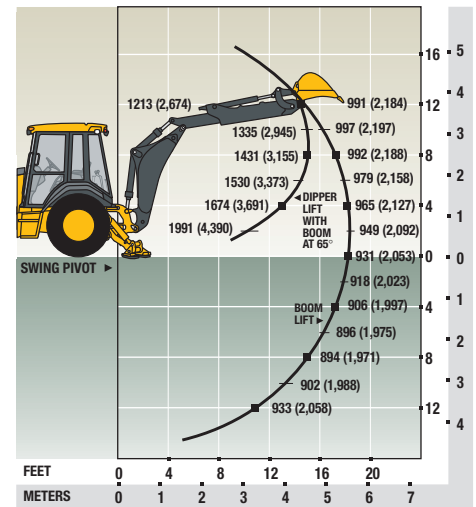

For more detailed spec information and available options, log on to www.JohnDeere.com.

310SJ with Total Machine Control™



See page 20 for Engine, Cooling, and Powertrain information.

Hydraulics

310SJ TMC

Main Pump	pressure-compensated load-sensing (PCLS) axial piston
Pump Flow @ 2,200 rpm	
Backhoe	159 L/m (42 gpm)
Loader	159 L/m (42 gpm)
System Relief Pressure	
Backhoe	24 993 kPa (3,625 psi)
Loader	24 993 kPa (3,625 psi)
Backhoe Controls	TMC electrohydraulic controls standard; auxiliary functions optional
Loader Controls	TMC electrohydraulic controls standard; auxiliary function and TMC tool carrier optional

Cylinders

Type	heat-treated, chrome-plated, polished rods; hardened-steel (replaceable bushings) pivot pins		
	<i>Bore</i>	<i>Rod Diameter</i>	<i>Stroke</i>
Loader Boom (2)	80 mm (3.15 in.)	50 mm (1.97 in.)	790 mm (31.10 in.)
Tool-Carrier Option (2)	90 mm (3.54 in.)	50 mm (1.97 in.)	672.9 mm (26.49 in.)
Loader Bucket (1)	90 mm (3.54 in.)	50 mm (1.97 in.)	744 mm (29.29 in.)
Tool-Carrier Option (1)	100 mm (3.94 in.)	56 mm (2.20 in.)	729.8 mm (28.73 in.)
Backhoe Boom (1)	120 mm (4.72 in.)	56 mm (2.20 in.)	795 mm (31.30 in.)
Backhoe Crowd (1)	115 mm (4.53 in.)	63 mm (2.48 in.)	602.5 mm (23.72 in.)
Backhoe Bucket (1)	100 mm (3.94 in.)	63 mm (2.48 in.)	810 mm (31.89 in.)
Backhoe Swing (2)	90 mm (3.54 in.)	50 mm (1.97 in.)	278 mm (10.94 in.)
Backhoe Extendable Dipperstick (1)	70 mm (2.76 in.)	40 mm (1.57 in.)	1067 mm (42.01 in.)
Backhoe Stabilizer			
Standard (2)	90 mm (3.54 in.)	50 mm (1.97 in.)	500 mm (19.69 in.)
Longer Optional (2)	100 mm (3.94 in.)	50 mm (1.97 in.)	500 mm (19.69 in.)
Non-Powered Axle (1)	70 mm (2.76 in.)	42 mm (1.65 in.)	213 mm (8.39 in.)
Mechanical-Front-Wheel Drive (1)	67 mm (2.64 in.)	42 mm (1.65 in.)	210 mm (8.27 in.)

Electrical

Voltage	12 volt
Alternator Rating	120 amp
Lights	4 halogen: 2 front and 2 rear (32,500 candlepower each); turn signals and flashers 2 front and 2 rear; stop and taillights and 2 rear reflectors

Operator Station

Type (SAE J1040)	canopy, isolation mounted, ROPS/FOPS, left/right access, with molded roof
------------------	---

Tires/Wheels

	<i>Front</i>	<i>Rear</i>
Non-Powered Front Axle	11L-16 SL F-3 (12)	19.5L-24 R-4 (10)
Mechanical-Front-Wheel Drive	12.5/80-18 I-3 (10) 340/80R18 XMCL	19.5L-24 R-4 (10) 500/70R24 XMCL

Serviceability

Hydraulic Oil Filter, Spin-On Enclosed Replaceable Element, Vertically Mounted	6-micron filtration / 1,000 service hours
--	---

Refill Capacities

Cooling System	25 L (26 qt.)
Rear Axle	18 L (19 qt.)
Engine Oil (including vertical spin-on filter)	13 L (14 qt.)
Torque Converter and Transmission	15 L (16 qt.)
Fuel Tank (with ground-level fueling)	155 L (41 gal.)
Hydraulic System	91 L (24 gal.)
Hydraulic Reservoir	39 L (10.2 gal.)
Mechanical-Front-Wheel-Drive Housing	
Axle	6.5 L (7 qt.)
Planetary (each)	1 L (1 qt.)

Operating Weights

310SJ TMC

With Full Fuel Tank, 79-kg (175 lb.) Operator, and Standard Equipment (Cab, Extendable Dipperstick, and 567-kg [1,250 lb.] Counterweight) 8171 kg (18,017 lb.)

Optional Components

Tool Carrier (includes mechanical-front-wheel drive) 482 kg (1,062 lb.)
Backhoe Bucket Coupler 63 kg (138 lb.)

Overall Dimensions

A Ground Clearance (minimum) 330 mm (13 in.)
B Overall Length (transport) 7.16 m (23 ft. 6 in.)
C Width over Tires 2.18 m (7 ft. 2 in.)
D Height to Top of ROPS/Cab 2.79 m (9 ft. 2 in.)
E Length from Axle to Axle
Non-Powered Front Axle 2.11 m (6 ft. 11 in.)
Mechanical-Front-Wheel-Drive Axle 2.14 m (7 ft. 0 in.)

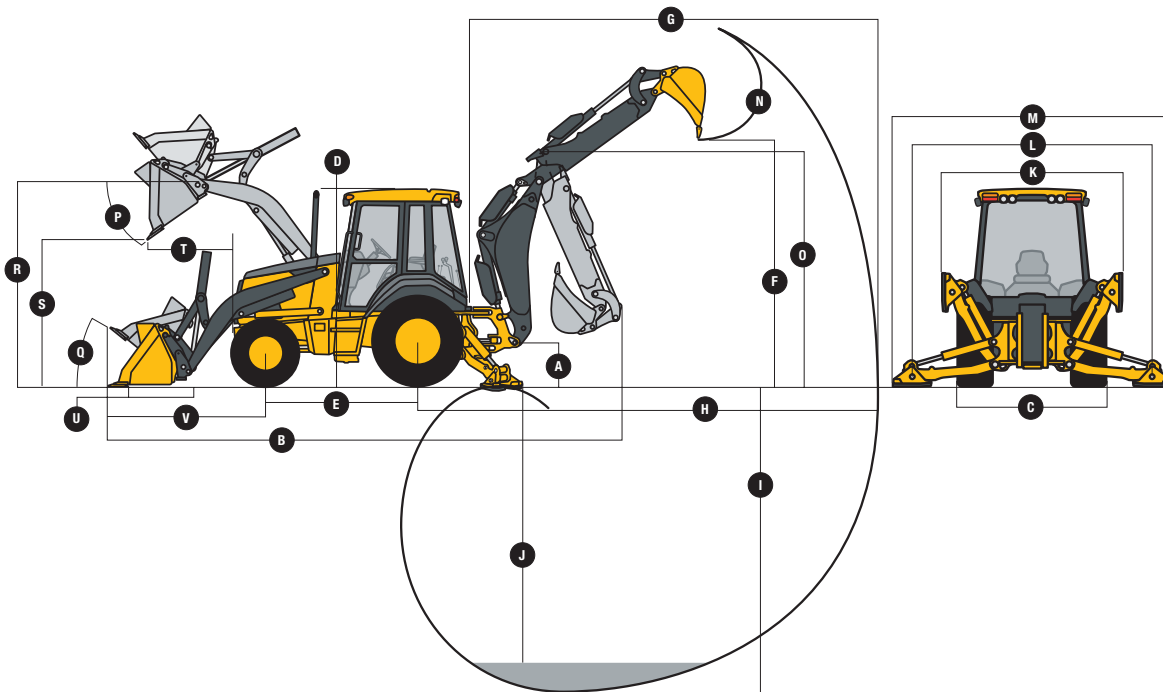

Backhoe Dimensions / Performance

310SJ TMC

Backhoe specifications are with 610-mm x

0.21-m³ (24 in. x 7.5 cu. ft.) bucket

Bucket Range 305–762 mm (12–30 in.)

Digging Force

Bucket Cylinder 67.8 kN (15,236 lb.)

Crowd Cylinder 36.0 kN (8,090 lb.)

Swing Arc 180 deg.

Operator Control two joysticks

With Extendable Dipperstick

Retracted

Extended

F Loading Height (truck loading position) 3.43 m (11 ft. 3 in.) 4.29 m (14 ft. 1 in.)

G Reach from Center of Swing Pivot 5.66 m (18 ft. 7 in.) 6.68 m (21 ft. 11 in.)

H Reach from Center of Rear Axle 6.73 m (22 ft. 1 in.) 7.72 m (25 ft. 4 in.)

I Digging Depth (SAE maximum) 4.55 m (14 ft. 11 in.) 5.61 m (18 ft. 5 in.)

J Digging Depth (SAE)

610-mm (2 ft.) Flat Bottom 4.50 m (14 ft. 9 in.) 5.56 m (18 ft. 3 in.)

2440-mm (8 ft.) Flat Bottom 4.19 m (13 ft. 9 in.) 5.33 m (17 ft. 6 in.)

K Stabilizer Width (transport) 2.18 m (7 ft. 2 in.) 2.18 m (7 ft. 2 in.)

L Stabilizer Spread (operating)

Standard Stabilizers 3.10 m (10 ft. 2 in.) 3.10 m (10 ft. 2 in.)

Long Stabilizers 3.45 m (11 ft. 4 in.) 3.45 m (11 ft. 4 in.)

M Stabilizer Overall Width (operating)

Standard Stabilizers 3.53 m (11 ft. 7 in.) 3.53 m (11 ft. 7 in.)

Long Stabilizers 4.03 m (13 ft. 3 in.) 4.03 m (13 ft. 3 in.)

N Bucket Rotation 190 deg. 190 deg.

O Transport Height 3.48 m (11 ft. 5 in.) 3.48 m (11 ft. 5 in.)

Loader Dimensions / Performance

(See page 25 for line art)

310SJ TMC

P Bucket Dump Angle (maximum)	45 deg.					
Q Rollback Angle at Ground Level	40 deg.					
Bucket Capacity	<i>Heavy-duty</i>	<i>Heavy-duty</i>	<i>Heavy-duty long lip</i>	<i>Heavy-duty</i>	<i>Multipurpose</i>	<i>Multipurpose</i>
	0.77 m ³ (1.00 cu. yd.)	0.86 m ³ (1.12 cu. yd.)	0.96 m ³ (1.25 cu. yd.)	1.00 m ³ (1.31 cu. yd.)	0.96 m ³ (1.25 cu. yd.)	1.00 m ³ (1.31 cu. yd.)
Width	2184 mm (86 in.)	2184 mm (86 in.)	2184 mm (86 in.)	2337 mm (92 in.)	2184 mm (86 in.)	2337 mm (92 in.)
R Height to Bucket Hinge Pin (maximum)	3.40 m (11 ft. 2 in.)					
Standard Loader Option						
Weight	363 kg (800 lb.)	390 kg (860 lb.)	405 kg (892 lb.)	521 kg (1,148 lb.)	795 kg (1,750 lb.)	817 kg (1,800 lb.)
Breakout Force	49.6 kN (11,160 lb.)	49.2 kN (11,051 lb.)	45.4 kN (10,210 lb.)	45.8 kN (10,300 lb.)	43.1 kN (9,700 lb.)	42.9 kN (9,650 lb.)
Lift Capacity (full height)	3368 kg (7,419 lb.)	3338 kg (7,353 lb.)	3332 kg (7,340 lb.)	3269 kg (7,200 lb.)	3042 kg (6,700 lb.)	2996 kg (6,600 lb.)
S Dump Clearance (bucket at 45 deg.)	2.69 m (8 ft. 10 in.)					
T Reach at Full Height (bucket at 45 deg.)	785 mm (30.9 in.)					
U Digging Depth Below Ground (bucket level)	160 mm (6.3 in.)					
V Length From Front Axle Centerline to						
Bucket Cutting Edge	2.03 m (6 ft. 8 in.)	2.03 m (6 ft. 8 in.)	2.18 m (7 ft. 2 in.)	2.03 m (6 ft. 8 in.)	2.20 m (7 ft. 3 in.)	2.15 m (7 ft. 1 in.)
Tool-Carrier Loader Option						
Weight	379 kg (835 lb.)	396 kg (873 lb.)	390 kg (860 lb.)	493 kg (1,085 lb.)	766 kg (1,687 lb.)	789 kg (1,737 lb.)
Breakout Force	50.2 kN (11,287 lb.)	52.9 kN (11,900 lb.)	45.8 kN (10,300 lb.)	50.9 kN (11,450 lb.)	43.3 kN (9,740 lb.)	43.1 kN (9,680 lb.)
Lift Capacity (full height)	3190 kg (7,026 lb.)	3269 kg (7,200 lb.)	3008 kg (6,625 lb.)	3276 kg (7,215 lb.)	2701 kg (5,950 lb.)	2656 kg (5,850 lb.)
S Dump Clearance (bucket at 45 deg.)	2.58 m (8 ft. 6 in.)					
T Reach at Full Height (bucket at 45 deg.)	777 mm (30.6 in.)					
U Digging Depth Below Ground (bucket level)	140 mm (5.5 in.)					
V Length From Front Axle Centerline to						
Bucket Cutting Edge	2.15 m (7 ft. 1 in.)	2.15 m (7 ft. 1 in.)	2.30 m (7 ft. 7 in.)	2.15 m (7 ft. 1 in.)	2.32 m (7 ft. 7 in.)	2.27 m (7 ft. 5 in.)

Lift Capacity with Quick-Coupler / Forks

Hydraulic Capacity	1219-mm (48 in.) tines	1524-mm (60 in.) tines
A' Maximum Height	2211 kg (4,875 lb.)	2053 kg (4,526 lb.)
B' Maximum Reach	3438 kg (7,580 lb.)	3294 kg (7,261 lb.)
C' At Ground Line	4400 kg (9,700 lb.)	4180 kg (9,215 lb.)
D' Below Ground Line	211 mm (8.3 in.)	211 mm (8.3 in.)

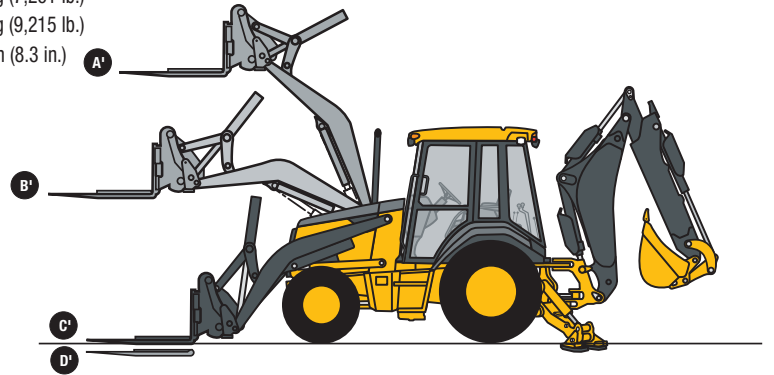

Lift capacities are over-end values in kg (lb.) according to SAE J31. Figures listed are 87% of the maximum lift force available. Base vehicle includes counterweight.

310SJ TMC Backhoe with 1.07-m (3 ft. 6 in.) Extendable Dipperstick, Retracted

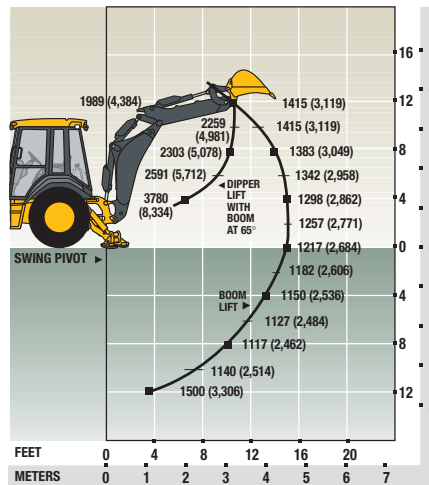

310SJ TMC Backhoe with 1.07-m (3 ft. 6 in.) Extendable Dipperstick, Extended

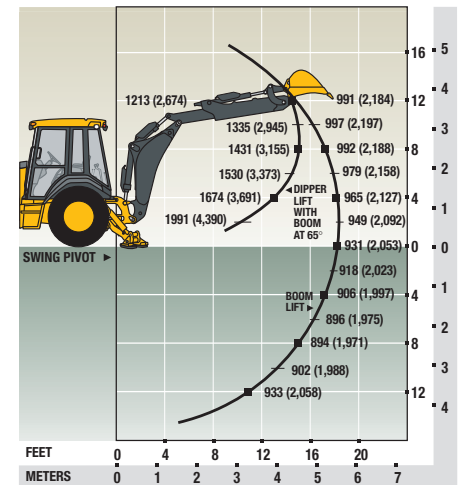

410J

Engine

410J

	<i>For use in U.S., Canada, and Europe</i>	<i>For use outside U.S., Canada, and Europe</i>
Manufacturer and Model	John Deere PowerTech™ E 4045HT054 turbocharged, standard	John Deere 4045T PowerTech turbocharged, standard*
Non-Road Emissions Standard	EPA Tier 3/EU Stage IIIA	EPA Tier 2/EU Stage II
Displacement	4.5 L (276 cu. in.)	4.5 L (276 cu. in.)
Net Peak Power (ISO9249)	73 kW (98 hp) @ 2,000 rpm	72 kW (96 hp) @ 2,100 rpm
Net Peak Torque (ISO9249)	416 Nm (306 lb.-ft.) @ 1,300 rpm	378 Nm (278 lb.-ft.) @ 1,500 rpm
Net Torque Rise	47%	26%
Lubrication	pressure system with spin-on filter and cooler	pressure system with spin-on filter and cooler
Air Cleaner	dual-stage dry type with safety element and evacuator valve	dual-stage dry type with safety element and evacuator valve

*This engine not available on 410J TMC.

Cooling

Fan Type	suction
Engine Coolant Rating	-37 deg. C (-34 deg. F)
Engine Oil Cooler	oil to water

Powertrain

Transmission 4-speed, helical-cut gears, full PowerShift™ with hydraulic reverser standard; electric clutch cutoff on loader lever

Torque Converter single stage, dual phase with 2.63:1 stall ratio; 280 mm (11 in.)

Maximum Travel Speeds with Standard

Engine	<i>Forward</i>	<i>Reverse</i>
Gear 1	5.9 km/h (3.7 mph)	7.4 km/h (4.6 mph)
Gear 2	10.8 km/h (6.7 mph)	13.6 km/h (8.5 mph)
Gear 3	21.9 km/h (13.6 mph)	21.6 km/h (13.4 mph)
Gear 4	37.4 km/h (23.2 mph)	N/A

Axles

Axle Oscillations, Stop to Stop (both axles) 22 deg.

Axle Ratings	<i>Mechanical-</i>		
	<i>Standard</i>	<i>front-wheel drive</i>	<i>Rear</i>
Static	18 000 kg (39,683 lb.)	12 000 kg (26,455 lb.)	13 000 kg (28,660 lb.)
Dynamic	7200 kg (15,873 lb.)	6000 kg (13,228 lb.)	7000 kg (15,432 lb.)
Ultimate	32 950 kg (72,642 lb.)	28 200 kg (62,170 lb.)	30 600 kg (67,461 lb.)

Differentials hydraulic locking rear, electric, foot actuated; limited slip front

Steering (ISO5010) hydrostatic power and emergency steering

Axle *Mechanical-*
front-wheel drive *Non-powered front*

Curb-Turning Radius		
With Brakes	3.58 m (11 ft. 9 in.)	3.44 m (11 ft. 4 in.)
Without Brakes	4.08 m (13 ft. 5 in.)	3.94 m (12 ft. 11 in.)
Bucket Clearance Circle		
With Brakes	10.11 m (33 ft. 2 in.)	9.89 m (32 ft. 5 in.)
Without Brakes	11.05 m (36 ft. 3 in.)	10.76 m (35 ft. 4 in.)
Steering Wheel Turns (lock to lock, flow amplified)	2.6 to 3.6	3.1 to 4.4

Final Drive

Mechanical-Front Wheel heavy-duty, outboard planetary final drives distribute shock loads over 3 gears

Rear Axle heavy-duty, outboard planetary final drives distribute shock loads over 4 gears

Brakes (conform to ISO 3450)

Service power assisted, hydraulic wet disc, mounted inboard, self-adjusting and self-equalizing

Parking spring-applied, hydraulically released, wet, multi disc, independent of service brakes with electric switch control

Hydraulics

410J

Main Pump	pressure-compensated load sensing (PCLS), axial piston
Pump Flow @ 2,200 rpm	
Backhoe	159 L/m (42 gpm)
Loader	159 L/m (42 gpm)
System Relief Pressure	
Backhoe	24 993 kPa (3,625 psi)
Loader	24 993 kPa (3,625 psi)
Backhoe Controls	two-lever manual standard; pilot controls with pattern select, three-lever manual controls with foot swing, and manual and/or electric auxiliary functions optional
Loader Controls	single-lever control with electric clutch cutoff switch standard; manual auxiliary function optional

Cylinders

Type	heat-treated, chrome-plated, polished rods; hardened-steel (replaceable bushings) pivot pins		
	<i>Bore</i>	<i>Rod Diameter</i>	<i>Stroke</i>
Loader Boom (2)	80 mm (3.15 in.)	50 mm (1.97 in.)	790 mm (31.10 in.)
Loader Bucket (1)	90 mm (3.54 in.)	50 mm (1.97 in.)	744 mm (29.29 in.)
Backhoe Boom (1)	125 mm (4.92 in.)	63 mm (2.48 in.)	897 mm (35.31 in.)
Backhoe Crowd (1)	115 mm (4.53 in.)	63 mm (2.48 in.)	698 mm (27.49 in.)
Backhoe Bucket (1)	100 mm (3.94 in.)	63 mm (2.48 in.)	810 mm (31.89 in.)
Backhoe Swing (2)	90 mm (3.54 in.)	50 mm (1.97 in.)	278 mm (10.94 in.)
Backhoe Extendable Dipperstick (1)	70 mm (2.76 in.)	40 mm (1.57 in.)	1214 mm (47.78 in.)
Backhoe Stabilizer, Standard (2)	100 mm (3.94 in.)	50 mm (1.97 in.)	500 mm (19.69 in.)
Non-Powered Axle (1)	70 mm (2.76 in.)	42 mm (1.65 in.)	213 mm (8.39 in.)
Mechanical-Front-Wheel Drive (1)	67 mm (2.64 in.)	42 mm (1.65 in.)	210 mm (8.27 in.)

Electrical

Voltage	12 volt
Alternator Rating	90 amp
Lights	4 halogen: 2 front and 2 rear (32,500 candlepower each); turn signals and flashers 2 front and 2 rear; stop and taillights and 2 rear reflectors

Operator Station

Type (SAE J1040)	canopy, isolation mounted, ROPS/FOPS, left/right access, with molded roof
------------------	---

Tires/Wheels

	<i>Front</i>	<i>Rear</i>
Non-Powered Front Axle	11L-16 SL F-3 (12) 14.5/75-16.1 SL F-3 (10)	19.5L-24 R-4 (10) 21L-24 R-4 (10)
Mechanical-Front-Wheel Drive	12.5/80-18 I-3 (10) 340/80R18 XMCL 12.5/80-18 I-3 (10)	19.5L-24 R-4 (10) 500/70R24 XMCL 21L-24 R-4 (10)

Serviceability

Hydraulic Oil Filter, Spin-On Enclosed Replaceable Element, Vertically Mounted	6-micron filtration / 1,000 service hours
--	---

Refill Capacities

Cooling System	25 L (26 qt.)
Rear Axle	18 L (19 qt.)
Engine Oil (including vertical spin-on filter)	13 L (14 qt.)
Torque Converter and Transmission	15 L (16 qt.)
Fuel Tank (with ground-level fueling)	155 L (41 gal.)
Hydraulic System	95 L (25 gal.)
Hydraulic Reservoir	39 L (10.2 gal.)
Mechanical-Front-Wheel-Drive Housing	
Axle	6.5 L (7 qt.)
Planetary (each)	1 L (1 qt.)

Operating Weights

With Full Fuel Tank, 79-kg (175 lb.) Operator, and Standard Equipment	6839 kg (15,080 lb.)
Typical with Cab, Mechanical-Front-Wheel Drive, Extendable Dipperstick, and 454-kg (1,000 lb.) Counterweight	8426 kg (18,580 lb.)
Optional Components	
Cab	263 kg (580 lb.)
Mechanical-Front-Wheel Drive with Tires	220 kg (485 lb.)
Extendable Dipperstick	289 kg (638 lb.)
Front Loader Coupler	286 kg (630 lb.)
Backhoe Bucket Coupler	63 kg (138 lb.)

Overall Dimensions

410J

- A** Ground Clearance (minimum) 356 mm (14 in.)
- B** Overall Length (transport) 7.29 m (23 ft. 11 in.)
- C** Width over Tires 2.18 m (7 ft. 2 in.)
- D** Height to Top of ROPS/Cab 2.82 m (9 ft. 3 in.)
- E** Length from Axle to Axle
 - Non-Powered Front Axle 2.11 m (6 ft. 11 in.)
 - Mechanical-Front-Wheel-Drive Axle 2.14 m (7 ft. 0 in.)

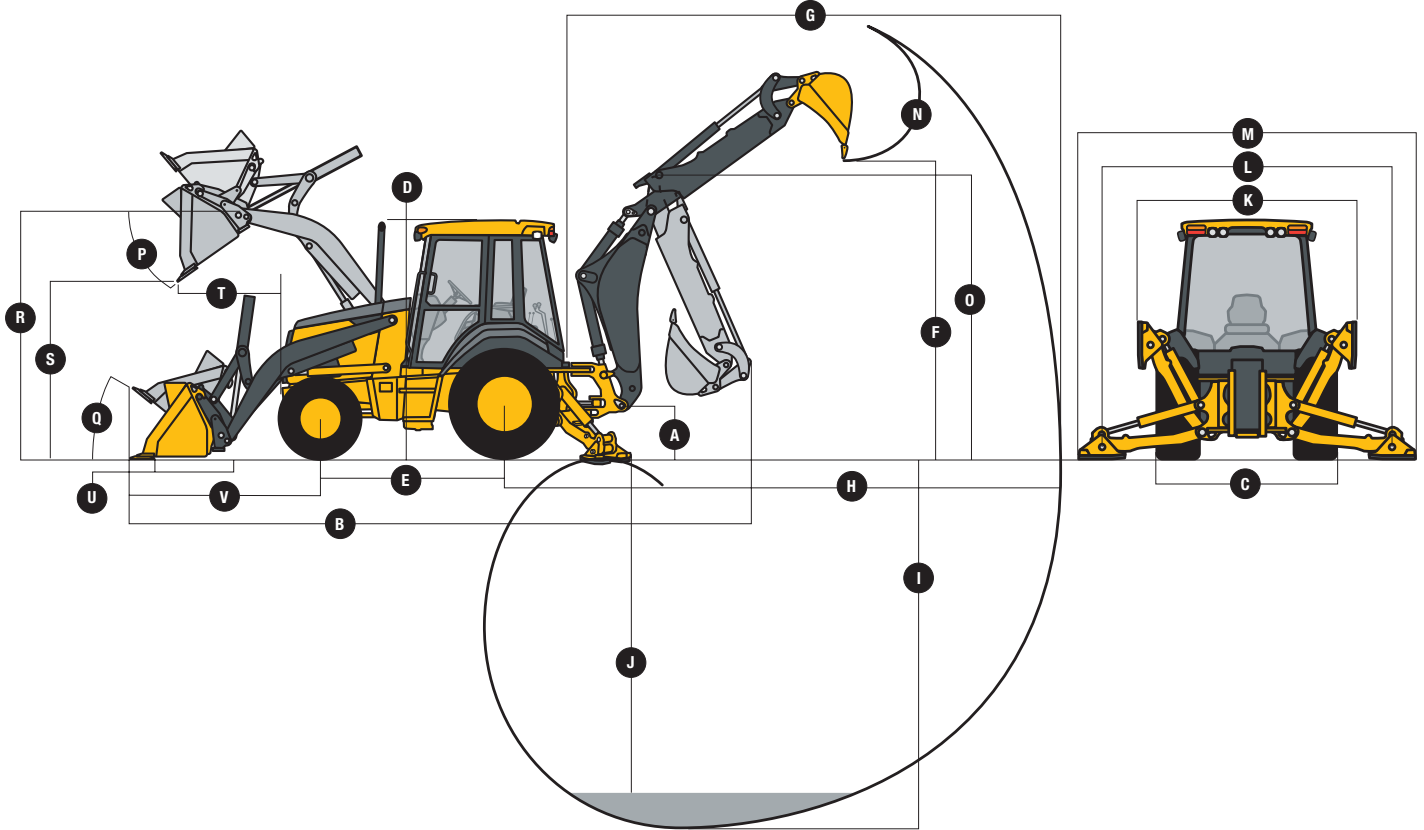

Backhoe Dimensions / Performance

410J

Backhoe specifications are with 610-mm x 0.21 m³ (24 in. x 7.5 cu. ft.) bucket

- Bucket Range 305–762 mm (12–30 in.)
- Digging Force
 - Bucket Cylinder 65.8 kN (14,801 lb.)
 - Crowd Cylinder 38.9 kN (8,741 lb.)
- Swing Arc 180 deg.
- Operator Control two levers

	<i>With Standard Backhoe</i>	<i>With Optional Extendable Dipperstick Retracted</i>	<i>Extended</i>
F Loading Height (truck loading position)	3.81 m (12 ft. 6 in.)	3.86 m (12 ft. 8 in.)	4.72 m (15 ft. 6 in.)
G Reach from Center of Swing Pivot	5.99 m (19 ft. 8 in.)	6.07 m (19 ft. 11 in.)	7.21 m (23 ft. 8 in.)
H Reach from Center of Rear Axle	7.11 m (23 ft. 4 in.)	7.19 m (23 ft. 7 in.)	8.33 m (27 ft. 4 in.)
I Digging Depth (SAE maximum)	4.83 m (15 ft. 10 in.)	4.90 m (16 ft. 1 in.)	6.10 m (20 ft. 0 in.)
J Digging Depth (SAE)			
610-mm (2 ft.) Flat Bottom	4.78 m (15 ft. 8 in.)	4.85 m (15 ft. 11 in.)	6.07 m (19 ft. 11 in.)
2440-mm (8 ft.) Flat Bottom	4.45 m (14 ft. 7 in.)	4.55 m (14 ft. 11 in.)	5.82 m (19 ft. 1 in.)
K Stabilizer Width (transport)	2.30 m (7 ft. 7 in.)	2.30 m (7 ft. 7 in.)	2.30 m (7 ft. 7 in.)
L Stabilizer Spread (operating)	3.45 m (11 ft. 4 in.)	3.45 m (11 ft. 4 in.)	3.45 m (11 ft. 4 in.)
M Stabilizer Overall Width (operating)	4.03 m (13 ft. 3 in.)	4.03 m (13 ft. 3 in.)	4.03 m (13 ft. 3 in.)
N Bucket Rotation	190 deg.	190 deg.	190 deg.
O Transport Height	3.94 m (12 ft. 11 in.)	3.91 m (12 ft. 10 in.)	3.91 m (12 ft. 10 in.)

Loader Dimensions / Performance

(See page 29 for line art)

410J

P Bucket Dump Angle (maximum)	45 deg.			
Q Rollback Angle at Ground Level	40 deg.			
	<i>Heavy-duty long lip</i>	<i>Heavy-duty</i>	<i>Heavy-duty</i>	<i>Multipurpose</i>
Bucket Capacity	0.96 m ³ (1.25 cu. yd.)	1.00 m ³ (1.31 cu. yd.)	1.15 m ³ (1.50 cu. yd.)	1.00 m ³ (1.31 cu. yd.)
Width	2184 mm (86 in.)	2337 mm (92 in.)	2388 mm (94 in.)	2337 mm (92 in.)
Weight	405 kg (892 lb.)	521 kg (1,148 lb.)	548 kg (1,208 lb.)	817 kg (1,800 lb.)
Breakout Force	45.4 kN (10,210 lb.)	45.8 kN (10,300 lb.)	45.2 kN (10,170 lb.)	42.9 kN (9,650 lb.)
Lift Capacity (full height)	3332 kg (7,340 lb.)	3269 kg (7,200 lb.)	3210 kg (7,070 lb.)	2996 kg (6,600 lb.)
R Height to Bucket Hinge Pin (maximum)	3.35 m (11 ft. 0 in.)	3.35 m (11 ft. 0 in.)	3.35 m (11 ft. 0 in.)	3.35 m (11 ft. 0 in.)
S Dump Clearance (bucket at 45 deg.)	2.54 m (8 ft. 4 in.)	2.69 m (8 ft. 10 in.)	2.67 m (8 ft. 9 in.)	2.62 m (8 ft. 7 in.)
T Reach at Full Height (bucket at 45 deg.)	902 mm (35.5 in.)	762 mm (30.0 in.)	787 mm (31.0 in.)	818 mm (32.2 in.)
U Digging Depth Below Ground (bucket level)	107 mm (4.2 in.)	170 mm (6.7 in.)	157 mm (6.2 in.)	182 mm (7.2 in.)
V Length From Front Axle Centerline to Bucket Cutting Edge	2.18 m (7 ft. 2 in.)	2.03 m (6 ft. 8 in.)	2.03 m (6 ft. 8 in.)	2.15 m (7 ft. 1 in.)

Lift Capacity with Quick-Coupler / Forks

Hydraulic Capacity	1219-mm (48 in.) tines	1524-mm (60 in.) tines
A' Maximum Height	2073 kg (4,570 lb.)	1891 kg (4,170 lb.)
B' Maximum Reach	3162 kg (6,971 lb.)	3003 kg (6,621 lb.)
C' At Ground Line	4145 kg (9,138 lb.)	3883 kg (8,561 lb.)
D' Below Ground Line	211 mm (8.3 in.)	211 mm (8.3 in.)

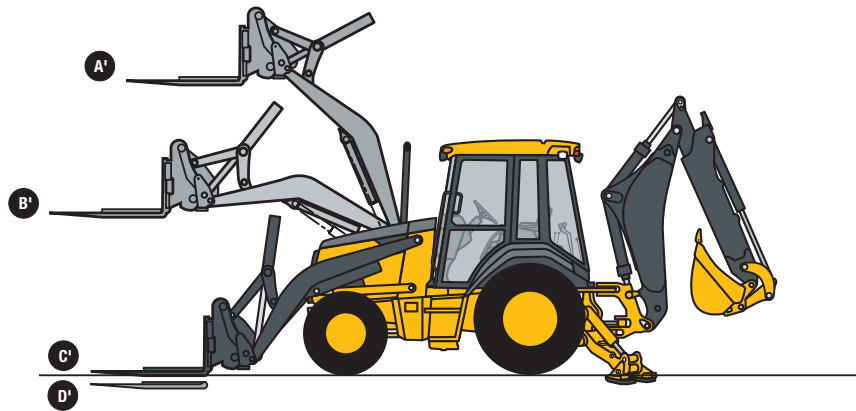

Lift capacities are over-end values in kg (lb.) according to SAE J31. Figures listed are 87% of the maximum lift force available. Base vehicle includes counterweight.

410J Backhoe with Standard Dipperstick

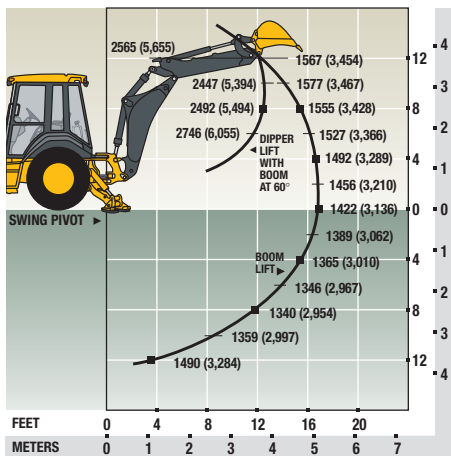

410J Backhoe with 1.22-m (4 ft.) Extendable Dipperstick, Retracted

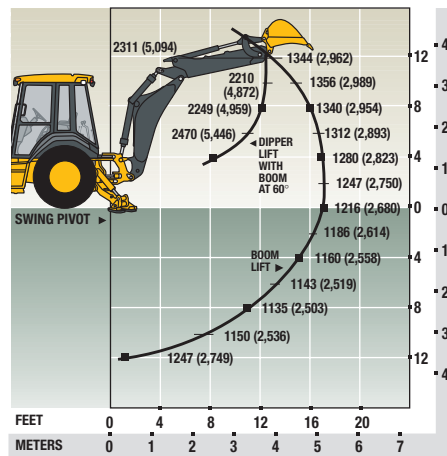

410J Backhoe with 1.22-m (4 ft.) Extendable Dipperstick, Extended

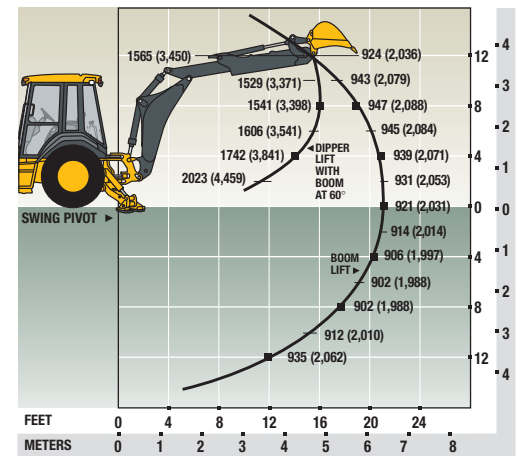

For more detailed spec information and available options, log on to www.JohnDeere.com.

410J with Total Machine Control™

410J.TC

See page 27 for Engine, Cooling, and Powertrain information.

Hydraulics

410J TMC

Main Pump	pressure-compensated load-sensing (PCLS) axial piston
Pump Flow @ 2,200 rpm	
Backhoe	159 L/m (42 gpm)
Loader	159 L/m (42 gpm)
System Relief Pressure	
Backhoe	24 993 kPa (3,625 psi)
Loader	24 993 kPa (3,625 psi)
Backhoe Controls	TMC electrohydraulic controls standard; auxiliary functions optional
Loader Controls	TMC electrohydraulic controls standard; auxiliary function and TMC tool carrier optional

Cylinders

Type	heat-treated, chrome-plated, polished rods; hardened-steel (replaceable bushings) pivot pins		
	<i>Bore</i>	<i>Rod Diameter</i>	<i>Stroke</i>
Loader Boom (2)	80 mm (3.15 in.)	50 mm (1.97 in.)	790 mm (31.10 in.)
Tool-Carrier Option (2)	90 mm (3.54 in.)	50 mm (1.97 in.)	672.9 mm (26.49 in.)
Loader Bucket (1)	90 mm (3.54 in.)	50 mm (1.97 in.)	744 mm (29.29 in.)
Tool-Carrier Option (1)	100 mm (3.94 in.)	56 mm (2.20 in.)	729.8 mm (28.73 in.)
Backhoe Boom (1)	125 mm (4.92 in.)	63 mm (2.48 in.)	897 mm (35.31 in.)
Backhoe Crowd (1)	115 mm (4.53 in.)	63 mm (2.48 in.)	698.2 mm (27.49 in.)
Backhoe Bucket (1)	100 mm (3.94 in.)	63 mm (2.48 in.)	810 mm (31.89 in.)
Backhoe Swing (2)	90 mm (3.54 in.)	50 mm (1.97 in.)	278 mm (10.94 in.)
Backhoe Extendable Dipperstick (1)	70 mm (2.76 in.)	40 mm (1.57 in.)	1214 mm (47.78 in.)
Backhoe Stabilizer, Standard (2)	100 mm (3.94 in.)	50 mm (1.97 in.)	500 mm (19.69 in.)
Non-Powered Axle (1)	70 mm (2.76 in.)	42 mm (1.65 in.)	213 mm (8.39 in.)
Mechanical-Front-Wheel Drive (1)	67 mm (2.64 in.)	42 mm (1.65 in.)	210 mm (8.27 in.)

Electrical

Voltage	12 volt
Alternator Rating	120 amp
Lights	4 halogen: 2 front and 2 rear (32,500 candlepower each); turn signals and flashers 2 front and 2 rear; stop and taillights and 2 rear reflectors

Operator Station

Type (SAE J1040)	canopy, isolation mounted, ROPS/FOPS, left/right access, with molded roof
------------------	---

Tires/Wheels

	<i>Front</i>	<i>Rear</i>
Non-Powered Front Axle	11L-16 SL F-3 (12)	19.5L-24 R-4 (10)
	14.5/75-16.1 SL F-3 (10)	21L-24 R-4 (10)
Mechanical-Front-Wheel Drive	12.5/80-18 I-3 (10)	19.5L-24 R-4 (10)
	340/80R18 XMCL	500/70R24 XMCL
	12.5/80-18 I-3 (10)	21L-24 R-4 (10)

Serviceability

Hydraulic Oil Filter, Spin-On Enclosed Replaceable Element, Vertically Mounted	6-micron filtration / 1,000 service hours
--	---

Refill Capacities

Cooling System	25 L (26 qt.)
Rear Axle	18 L (19 qt.)
Engine Oil (including vertical spin-on filter)	13 L (14 qt.)
Torque Converter and Transmission	15 L (16 qt.)
Fuel Tank (with ground-level fueling)	155 L (41 gal.)
Hydraulic System	95 L (25 gal.)
Hydraulic Reservoir	39 L (10.2 gal.)
Mechanical-Front-Wheel-Drive Housing	
Axle	6.5 L (7 qt.)
Planetary (each)	1 L (1 qt.)

Operating Weights **410J TMC**

With Full Fuel Tank, 79-kg (175 lb.) Operator, and Standard Equipment (Cab, Extendable Dipperstick, and 567-kg [1,250 lb.] Counterweight) 8626 kg (19,022 lb.)

Optional Components

Tool Carrier (includes mechanical-front-wheel drive) 482 kg (1,062 lb.)
 Backhoe Bucket Coupler 63 kg (138 lb.)

Overall Dimensions

- | | |
|--|--|
| A Ground Clearance (minimum) 356 mm (14 in.) | E Length from Axle to Axle |
| B Overall Length (transport) 7.29 m (23 ft. 11 in.) | Non-Powered Front Axle 2.11 m (6 ft. 11 in.) |
| C Width over Tires 2.18 m (7 ft. 2 in.) | Mechanical-Front-Wheel-Drive Axle 2.14 m (7 ft. 0 in.) |
| D Height to Top of ROPS/Cab 2.82 m (9 ft. 3 in.) | |

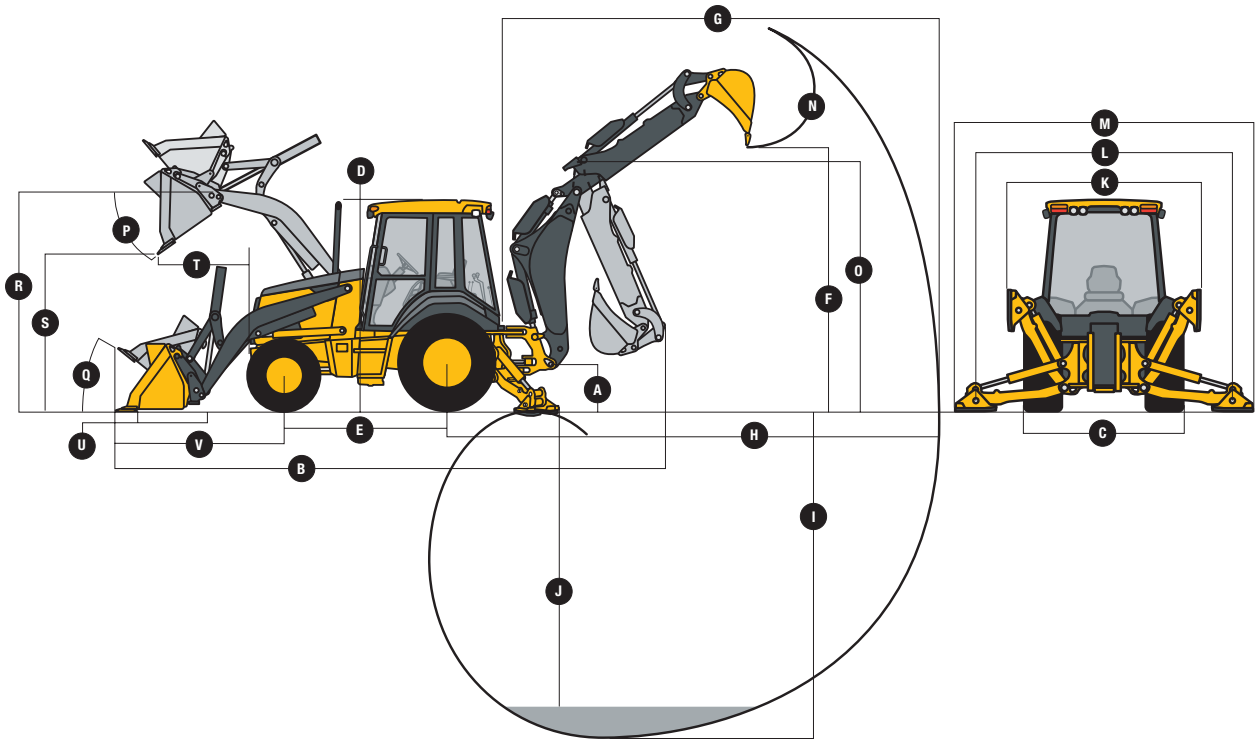

Backhoe Dimensions / Performance **410J TMC**

Backhoe specifications are with 610-mm x 0.21-m³ (24 in. x 7.5 cu. ft.) bucket

- | | |
|--|--|
| Bucket Range 305–762 mm (12–30 in.) | |
| Digging Force | |
| Bucket Cylinder 65.8 kN (14,801 lb.) | |
| Crowd Cylinder 38.9 kN (8,741 lb.) | |
| Swing Arc 180 deg. | |
| Operator Control two joysticks | |
| | <i>With Extendable Dipperstick</i> |
| | <i>Retracted Extended</i> |
| F Loading Height (truck loading position) 3.86 m (12 ft. 8 in.) | 4.72 m (15 ft. 6 in.) |
| G Reach from Center of Swing Pivot 6.07 m (19 ft. 11 in.) | 7.21 m (23 ft. 8 in.) |
| H Reach from Center of Rear Axle 7.19 m (23 ft. 7 in.) | 8.33 m (27 ft. 4 in.) |
| I Digging Depth (SAE maximum) 4.90 m (16 ft. 1 in.) | 6.10 m (20 ft. 0 in.) |
| J Digging Depth (SAE) | |
| 610-mm (2 ft.) Flat Bottom 4.85 m (15 ft. 11 in.) | 6.07 m (19 ft. 11 in.) |
| 2440-mm (8 ft.) Flat Bottom 4.55 m (14 ft. 11 in.) | 5.82 m (19 ft. 1 in.) |
| K Stabilizer Width (transport) 2.30 m (7 ft. 7 in.) | 2.30 m (7 ft. 7 in.) |
| L Stabilizer Spread (operating) 3.45 m (11 ft. 4 in.) | 3.45 m (11 ft. 4 in.) |
| M Stabilizer Overall Width (operating) 4.03 m (13 ft. 3 in.) | 4.03 m (13 ft. 3 in.) |
| N Bucket Rotation 190 deg. | 190 deg. |
| O Transport Height 3.91 m (12 ft. 10 in.) | 3.91 m (12 ft. 10 in.) |

Loader Dimensions / Performance 410J TMC

P Bucket Dump Angle (maximum)	45 deg.			
Q Rollback Angle at Ground Level	40 deg.			
	<i>Heavy-duty long lip</i>	<i>Heavy-duty</i>	<i>Heavy-duty</i>	<i>Multipurpose</i>
Bucket Capacity	0.96 m³ (1.25 cu. yd.)	1.00 m³ (1.31 cu. yd.)	1.15 m³ (1.50 cu. yd.)	1.00 m³ (1.31 cu. yd.)
Width	2184 mm (86 in.)	2337 mm (92 in.)	2388 mm (94 in.)	2337 mm (92 in.)
Standard Loader Option				
Weight	405 kg (892 lb.)	521 kg (1,148 lb.)	548 kg (1,208 lb.)	817 kg (1,800 lb.)
Breakout Force	45.4 kN (10,210 lb.)	45.8 kN (10,300 lb.)	45.2 kN (10,170 lb.)	42.9 kN (9,650 lb.)
Lift Capacity (full height)	3332 kg (7,340 lb.)	3269 kg (7,200 lb.)	3210 kg (7,070 lb.)	2996 kg (6,600 lb.)
R Height to Bucket Hinge Pin (maximum)	3.35 m (11 ft. 0 in.)	3.35 m (11 ft. 0 in.)	3.35 m (11 ft. 0 in.)	3.35 m (11 ft. 0 in.)
S Dump Clearance (bucket at 45 deg.)	2.54 m (8 ft. 4 in.)	2.69 m (8 ft. 10 in.)	2.67 m (8 ft. 9 in.)	2.62 m (8 ft. 7 in.)
T Reach at Full Height (bucket at 45 deg.)	902 mm (35.5 in.)	762 mm (30.0 in.)	787 mm (31.0 in.)	818 mm (32.2 in.)
U Digging Depth Below Ground (bucket level)	107 mm (4.2 in.)	170 mm (6.7 in.)	157 mm (6.2 in.)	182 mm (7.2 in.)
V Length From Front Axle Centerline to Bucket Cutting Edge	2.18 m (7 ft. 2 in.)	2.03 m (6 ft. 8 in.)	2.03 m (6 ft. 8 in.)	2.15 m (7 ft. 1 in.)
Tool-Carrier Loader Option				
Weight	390 kg (860 lb.)	493 kg (1,085 lb.)	520 kg (1,145 lb.)	789 kg (1,737 lb.)
Breakout Force	45.8 kN (10,300 lb.)	50.9 kN (11,450 lb.)	47.3 kN (10,640 lb.)	43.1 kN (9,680 lb.)
Lift Capacity (full height)	3008 kg (6,625 lb.)	3276 kg (7,215 lb.)	3094 kg (6,815 lb.)	2656 kg (5,850 lb.)
R Height to Bucket Hinge Pin (maximum)	3.40 m (11 ft. 2 in.)	3.40 m (11 ft. 2 in.)	3.35 m (11 ft. 0 in.)	3.40 m (11 ft. 2 in.)
S Dump Clearance (bucket at 45 deg.)	2.51 m (8 ft. 3 in.)	2.59 m (8 ft. 6 in.)	2.57 m (8 ft. 5 in.)	2.50 m (8 ft. 2 in.)
T Reach at Full Height (bucket at 45 deg.)	868 mm (34.2 in.)	762 mm (30.0 in.)	787 mm (31.0 in.)	836 mm (32.9 in.)
U Digging Depth Below Ground (bucket level)	122 mm (4.8 in.)	140 mm (5.5 in.)	140 mm (5.5 in.)	152 mm (6.0 in.)
V Length From Front Axle Centerline to Bucket Cutting Edge	2.30 m (7 ft. 7 in.)	2.15 m (7 ft. 1 in.)	2.15 m (7 ft. 1 in.)	2.27 m (7 ft. 5 in.)

Lift Capacity with Quick-Coupler / Forks

Hydraulic Capacity	1219-mm (48 in.) tines	1524-mm (60 in.) tines
A' Maximum Height	2211 kg (4,875 lb.)	2053 kg (4,526 lb.)
B' Maximum Reach	3438 kg (7,580 lb.)	3294 kg (7,261 lb.)
C' At Ground Line	4400 kg (9,700 lb.)	4180 kg (9,215 lb.)
D' Below Ground Line	211 mm (8.3 in.)	211 mm (8.3 in.)

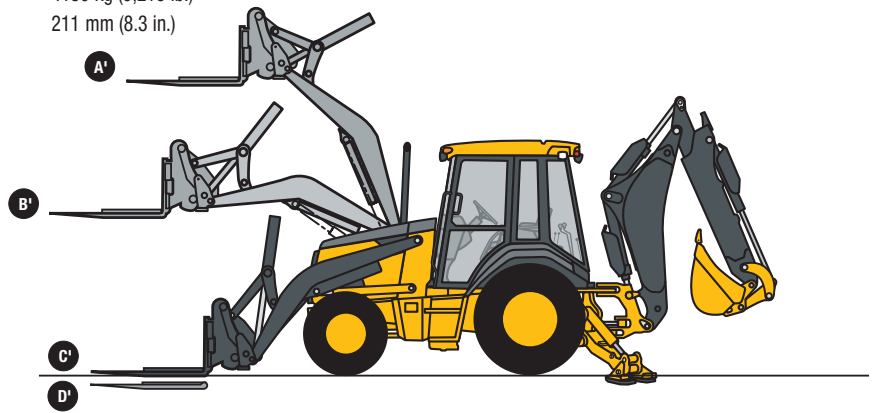

Lift capacities are over-end values in kg (lb.) according to SAE J31. Figures listed are 87% of the maximum lift force available. Base vehicle includes counterweight.

410J TMC Backhoe with 1.22-m (4 ft.) Extendable Dipperstick, Retracted

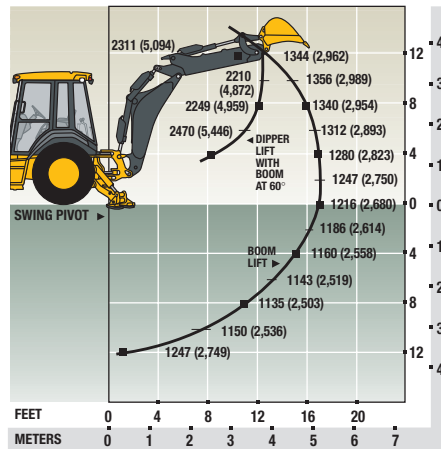

410J TMC Backhoe with 1.22-m (4 ft.) Extendable Dipperstick, Extended

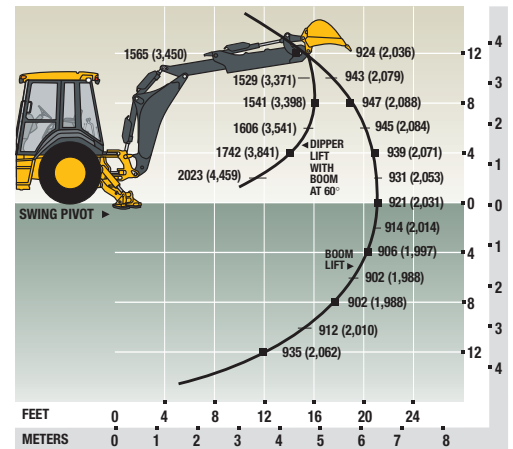

710J



Engine

710J

For use both in and outside U.S., Canada, and Europe

Manufacturer and Model	John Deere PowerTech™ E 6068HT067 turbocharged, standard
Non-Road Emissions Standard	EPA Tier 3/EU Stage IIIA
Displacement	6.8 L (414 cu. in.)
Net Peak Power (ISO9249)	94 kW (126 hp) @ 2,000 rpm
Net Peak Torque (ISO9249)	549 Nm (404 lb.-ft.) @ 1,300 rpm
Net Torque Rise	38%
Lubrication	pressure system with spin-on filter and cooler
Air Cleaner	dual-stage dry type with safety element and evacuator valve

Cooling

Fan Type	suction
Engine Coolant Rating	-37 deg. C (-34 deg. F)
Engine Oil Cooler	oil to water

Powertrain

Transmission	4-speed, helical-cut gears, full PowerShift™ with hydraulic reverser standard; electric clutch cutoff on loader lever
Torque Converter	single stage, dual phase with 1.95:1 stall ratio; 280 mm (11 in.)

Maximum Travel Speeds with Standard

Engine and 21L-28 Rear Tires	Forward	Reverse
With 15-19.5 Front Tires and Mechanical-Front-Wheel Drive		
Gear 1	6.1 km/h (3.8 mph)	6.9 km/h (4.3 mph)
Gear 2	10.3 km/h (6.4 mph)	11.4 km/h (7.1 mph)
Gear 3	24.9 km/h (15.5 mph)	27.5 km/h (17.1 mph)
Gear 4	36.0 km/h (22.4 mph)	N/A
With 14.5/75-16.1 Front Tires		
Gear 1	6.1 km/h (3.8 mph)	6.9 km/h (4.3 mph)
Gear 2	10.3 km/h (6.4 mph)	11.6 km/h (7.2 mph)
Gear 3	24.9 km/h (15.5 mph)	27.7 km/h (17.2 mph)
Gear 4	36.0 km/h (22.4 mph)	N/A

Axles

Axle Oscillations, Stop to Stop (both axles)	22 deg.		
Axle Ratings	<i>Mechanical-front-wheel drive</i>		
	<i>Standard</i>	<i>front-wheel drive</i>	<i>Rear</i>
Static	22 950 kg (50,596 lb.)	18 500 kg (40,786 lb.)	19 700 kg (43,431 lb.)
Dynamic	9200 kg (20,283 lb.)	7700 kg (16,976 lb.)	9800 kg (21,605 lb.)
Ultimate	41 000 kg (90,390 lb.)	43 600 kg (96,122 lb.)	46 400 kg (102,295 lb.)

Differentials hydraulic locking rear, electric, foot-actuated; limited slip front

Steering (ISO5010) hydrostatic power and emergency steering

Axle	<i>Mechanical-front-wheel drive</i>	
	<i>front-wheel drive</i>	<i>Non-powered front</i>
Curb-Turning Radius		
With Brakes	4.05 m (13 ft. 3 in.)	4.07 m (13 ft. 4 in.)
Without Brakes	4.62 m (15 ft. 2 in.)	4.65 m (15 ft. 3 in.)
Bucket Clearance Circle		
With Brakes	11.04 m (36 ft. 3 in.)	11.31 m (37 ft. 1 in.)
Without Brakes	12.07 m (39 ft. 7 in.)	12.31 m (40 ft. 5 in.)
Steering Wheel Turns (lock to lock, flow amplified)	2.7 to 4.4	2.8 to 4.5

Final Drive

Mechanical-Front Wheel	heavy-duty, inboard planetary final drives distribute shock loads over 3 gears
Rear Axle	heavy-duty, inboard planetary final drives distribute shock loads over 4 gears

Powertrain**710J****Brakes** (conform to ISO 3450)

- Service full power, hydraulic wet disc, mounted inboard, self-adjusting and self-equalizing
- Parking spring-applied, hydraulically released, wet, multi disc, independent of service brakes with electric switch control

Hydraulics

- Main Pump pressure-compensated load sensing (PCLS), axial piston
- Pump Flow @ 2,200 rpm
 - Backhoe 197 L/min. (52 gpm)
 - Loader 197 L/min. (52 gpm)
- System Relief Pressure
 - Backhoe 24 993 kPa (3,625 psi)
 - Loader 24 993 kPa (3,625 psi)
- Backhoe Controls** pilot controls with pattern select standard; two-lever manual, three-lever manual controls with foot swing, and manual and/or electric auxiliary functions optional
- Loader Controls** single-lever control with electric clutch cutoff switch standard; manual auxiliary function optional

Cylinders

- Type heat-treated, chrome-plated, polished rods; hardened-steel (replaceable bushings) pivot pins
- | | <i>Bore</i> | <i>Rod Diameter</i> | <i>Stroke</i> |
|---|-------------------|---------------------|---------------------|
| Loader Boom (2) | 100 mm (3.94 in.) | 56 mm (2.20 in.) | 805 mm (31.69 in.) |
| Loader Bucket (1) | 110 mm (4.33 in.) | 56 mm (2.20 in.) | 672 mm (26.44 in.) |
| Backhoe Boom (1) | 160 mm (6.30 in.) | 95 mm (3.74 in.) | 944 mm (37.17 in.) |
| Backhoe Crowd (1) | 140 mm (5.51 in.) | 85 mm (3.35 in.) | 792 mm (31.16 in.) |
| Backhoe Bucket (1) | 110 mm (4.33 in.) | 70 mm (2.76 in.) | 939 mm (36.97 in.) |
| Backhoe Swing (2) | 110 mm (4.33 in.) | 56 mm (2.20 in.) | 308 mm (12.13 in.) |
| Backhoe Extendable Dipperstick (1) | 80 mm (3.15 in.) | 45 mm (1.77 in.) | 1372 mm (54.00 in.) |
| Backhoe Stabilizer, Standard (2) | 115 mm (4.53 in.) | 63 mm (2.48 in.) | 588 mm (23.15 in.) |
| Non-Powered Axle (1) | 75 mm (2.95 in.) | 45 mm (1.77 in.) | 230 mm (9.06 in.) |
| Mechanical-Front-Wheel Drive (1) | 75 mm (2.95 in.) | 50 mm (1.97 in.) | 260 mm (10.24 in.) |

Electrical

- Voltage 12 volt
- Alternator Rating 90 amp
- Lights 4 halogen: 2 front and 2 rear (32,500 candlepower each); turn signals and flashers 2 front and 2 rear; stop and taillights and 2 rear reflectors

Operator Station

- Type (SAE J1040) canopy, isolation mounted, ROPS/FOPS, left/right access, with molded roof

Tires/Wheels

- | | <i>Front</i> | <i>Rear</i> |
|------------------------------------|--------------------------|------------------|
| Non-Powered Front Axle | 14.5/75-16.1 SL F-3 (10) | 21L-28 R-4 (14) |
| | 16.5L-16.1 SL F-3 (10) | 21L-28 R-4 (14) |
| Mechanical-Front-Wheel Drive | 15-19.5 NHS SS-1 (8) | 21L-28 R-4 (14) |
| | 15-19.5 NHS SS-1 (8) | 20.5-25 L-2 (12) |

Serviceability

- Hydraulic Oil Filter, Spin-On Enclosed Replaceable Element, Vertically Mounted 6-micron filtration / 1,000 service hours

Refill Capacities

- Cooling System 23 L (24.7 qt.)
- Rear Axle 16 L (17 qt.)
- Engine Oil (including vertical spin-on filter) 20 L (21.1 qt.)
- Torque Converter and Transmission 15.1 L (16 qt.)
- Fuel Tank (with ground-level fueling) 261 L (69 gal.)
- Hydraulic System 151 L (40 gal.)
- Hydraulic Reservoir 47 L (12.4 gal.)
- Mechanical-Front-Wheel-Drive Housing
 - Axle 9 L (9.5 qt.)
 - Planetary (each) 0.81 L (0.86 qt.)

Operating Weights

- With Full Fuel Tank, 79-kg (175 lb.) Operator, and Standard Equipment 10 431 kg (23,000 lb.)
- Typical with Cab, Mechanical-Front-Wheel Drive, Extendable Dipperstick, and 740-kg (1,630 lb.) Counterweight 11 791 kg (26,000 lb.)

Optional Components

- Cab 293 kg (645 lb.)
- Mechanical-Front-Wheel Drive with Tires 373 kg (822 lb.)
- Extendable Dipperstick 317 kg (700 lb.)
- Front Loader Coupler 363 kg (800 lb.)
- Backhoe Bucket Coupler 299 kg (660 lb.)

Overall Dimensions 710J

- A** Ground Clearance (minimum) 356 mm (14 in.)
- B** Overall Length (transport) 8.15 m (26 ft. 9 in.)
- C** Width over Tires 2.29 m (7 ft. 6 in.)
- D** Height to Top of ROPS/Cab 2.97 m (9 ft. 9 in.)
- E** Length from Axle to Axle
 - Non-Powered Front Axle 2.52 m (8 ft. 3 in.)
 - Mechanical-Front-Wheel-Drive Axle 2.49 m (8 ft. 2 in.)

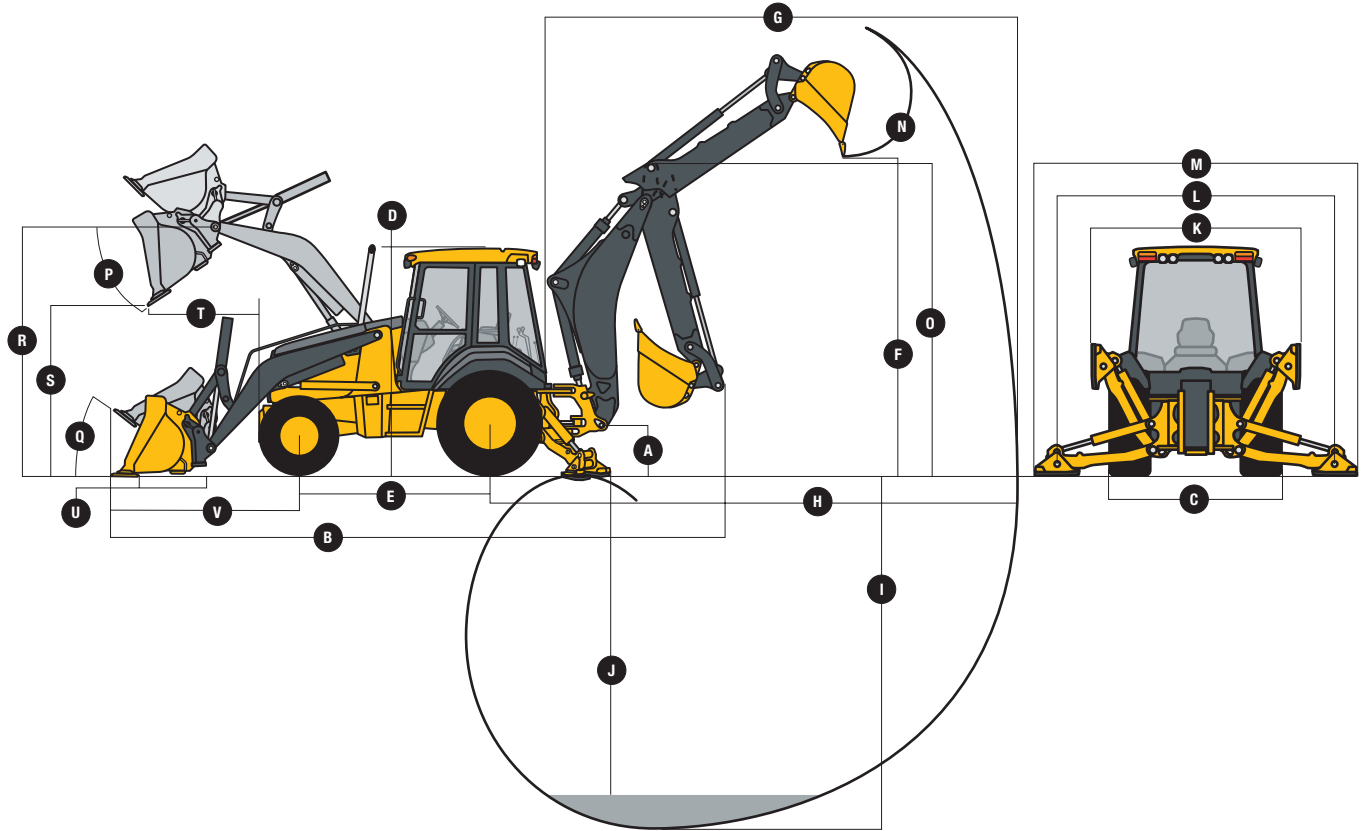

Backhoe Dimensions / Performance 710J

Backhoe specifications are with 610-mm x 0.31-m³ (24 in. x 11.1 cu. ft.) bucket

- Bucket Range 610–914 mm (24–36 in.)
- Digging Force
 - Bucket Cylinder 75.6 kN (17,000 lb.)
 - Crowd Cylinder 52.3 kN (11,750 lb.)
- Swing Arc 180 deg.
- Operator Control pilot control

	<i>With Standard Backhoe</i>	<i>With Optional Extendable Dipperstick Retracted</i>	<i>Extended</i>
F Loading Height (truck loading position)	4.34 m (14 ft. 3 in.)	4.34 m (14 ft. 3 in.)	5.18 m (17 ft. 0 in.)
G Reach from Center of Swing Pivot	6.86 m (22 ft. 6 in.)	6.86 m (22 ft. 6 in.)	8.19 m (26 ft. 10 in.)
H Reach from Center of Rear Axle	8.13 m (26 ft. 8 in.)	8.13 m (26 ft. 8 in.)	9.46 m (31 ft. 0 in.)
I Digging Depth (SAE maximum)	5.44 m (17 ft. 10 in.)	5.44 m (17 ft. 10 in.)	6.81 m (22 ft. 4 in.)
J Digging Depth (SAE)			
610-mm (2 ft.) Flat Bottom	5.41 m (17 ft. 9 in.)	5.41 m (17 ft. 9 in.)	6.83 m (22 ft. 5 in.)
2440-mm (8 ft.) Flat Bottom	5.18 m (17 ft. 0 in.)	5.18 m (17 ft. 0 in.)	6.58 m (21 ft. 7 in.)
K Stabilizer Width (transport)	2.41 m (7 ft. 11 in.)	2.41 m (7 ft. 11 in.)	2.41 m (7 ft. 11 in.)
L Stabilizer Spread (operating)	3.99 m (13 ft. 1 in.)	3.99 m (13 ft. 1 in.)	3.99 m (13 ft. 1 in.)
M Stabilizer Overall Width (operating)	4.65 m (15 ft. 3 in.)	4.65 m (15 ft. 3 in.)	4.65 m (15 ft. 3 in.)
N Bucket Rotation	190 deg.	190 deg.	190 deg.
O Transport Height	4.17 m (13 ft. 8 in.)	4.22 m (13 ft. 10 in.)	4.22 m (13 ft. 10 in.)

Loader Dimensions / Performance 710J

P Bucket Dump Angle (maximum)	45 deg.		
Q Rollback Angle at Ground Level	40 deg.		
	<i>Standard-duty</i>	<i>Standard-duty</i>	<i>Multipurpose</i>
Bucket Capacity	1.24 m ³ (1.62 cu. yd.)	1.43 m ³ (1.87 cu. yd.)	1.05 m ³ (1.375 cu. yd.)
Width	2464 mm (97 in.)	2464 mm (97 in.)	2451 mm (96.5 in.)
Weight	831 kg (1,830 lb.)	867 kg (1,909 lb.)	970 kg (2,136 lb.)
Breakout Force	69.1 kN (15,540 lb.)	65.8 kN (14,800 lb.)	69.8 kN (15,690 lb.)
Lift Capacity (full height)	4212 kg (9,277 lb.)	3947 kg (8,693 lb.)	3964 kg (8,732 lb.)
R Height to Bucket Hinge Pin (maximum)	3.78 m (12 ft. 5 in.)	3.78 m (12 ft. 5 in.)	3.78 m (12 ft. 5 in.)
S Dump Clearance (bucket at 45 deg.)	2.92 m (9 ft. 7 in.)	2.84 m (9 ft. 4 in.)	2.95 m (9 ft. 8 in.)
T Reach at Full Height (bucket at 45 deg.)	691 mm (27.2 in.)	770 mm (30.3 in.)	683 mm (26.9 in.)
U Digging Depth Below Ground (bucket level)	104 mm (4.1 in.)	104 mm (4.1 in.)	81 mm (3.2 in.)
V Length From Front Axle Centerline to Bucket Cutting Edge	2.10 m (6 ft. 11 in.)	2.21 m (7 ft. 3 in.)	2.06 m (6 ft. 9 in.)

Lift Capacity with Quick-Coupler / Forks

Hydraulic Capacity	1219-mm (48 in.) tines
A' Maximum Height	2632 kg (5,803 lb.)
B' Maximum Reach	4378 kg (9,651 lb.)
C' At Ground Line	6057 kg (13,353 lb.)
D' Below Ground Line	140 mm (5.5 in.)

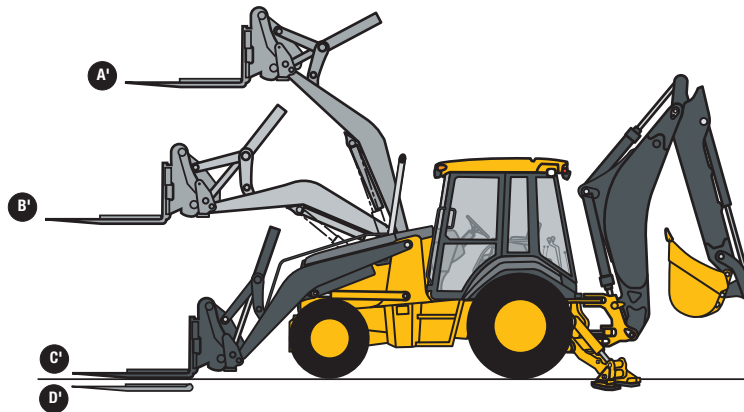

Lift capacities are over-end values in kg (lb.) according to SAE J31. Figures listed are 87% of the maximum lift force available. Base vehicle includes counterweight.

710J Backhoe with Standard Dipperstick

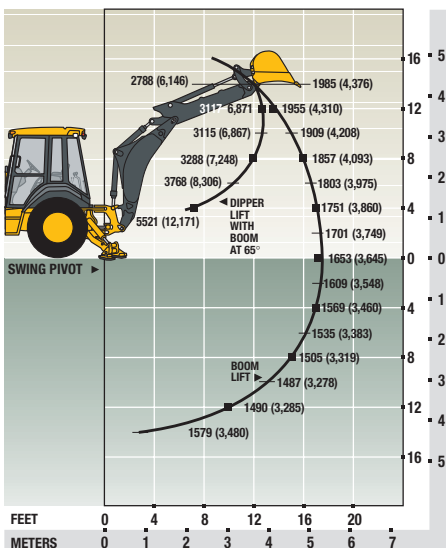

710J Backhoe with 1.37-m (4 ft. 6 in.) Extendable Dipperstick, Retracted

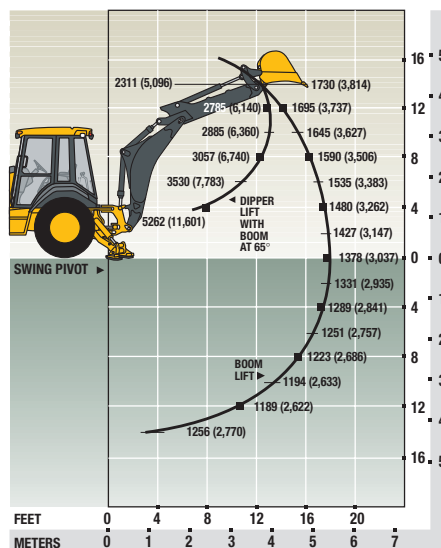

710J Backhoe with 1.37-m (4 ft. 6 in.) Extendable Dipperstick, Extended

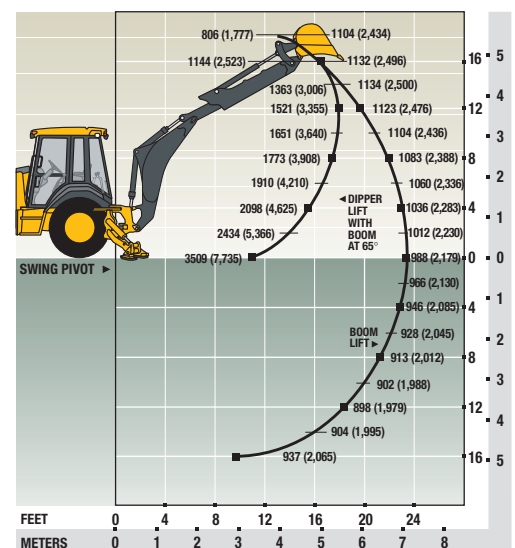

For more detailed spec information and available options, log on to www.JohnDeere.com.

310J / 310SJ / 410J / 710J BACKHOE LOADERS

Key: ● Standard equipment ▲ Optional equipment

*See your John Deere dealer for further information.

310J 310SJ 410J 710J Engine

- ● ● ● Meets EPA Tier 3/EU Stage IIIA emissions
- John Deere Model 4045HT054 – 4.5 liter, 63 kW (84 net peak hp) turbocharged, isolation mounted
- John Deere Model 4045HT054 – 4.5 liter, 69 kW (93 net peak hp) turbocharged, isolation mounted
- John Deere Model 4045HT054 – 4.5 liter, 73 kW (98 net peak hp) turbocharged, isolation mounted
- John Deere Model 6068HT067 – 6.8 liter, 94 kW (126 net peak hp) turbocharged, isolation mounted
- Vertical spin-on engine oil filter
- Vertical spin-on fuel filter with water separator
- Oil-to-water engine oil cooler
- Antifreeze, -37°C (-34°F)
- Coolant recovery tank
- Serpentine belt with automatic belt tensioner
- Suction-type cooling fan
- Enclosed safety fan guard
- ▲ ▲ ▲ High ambient temperature engine cooling
- Dual-element dry-type air cleaner
- Muffler, under hood with curved-end exhaust stack
- ▲ ▲ ▲ Chrome exhaust extension
- ▲ ▲ ▲ Cold-start package – electric ether starting aid and engine coolant heater, 1,000 watts

Powertrain

- ● ● ● PowerShift™ transmission: Torque converter with electrically actuated twist grip F-N-R with neutral safety switch interlock (1st through 4th gears)
- Transmission oil cooler
- Vertical spin-on transmission filter
- ▲ ▲ ▲ Transmission remote oil-sampling port
- Differential lock, electric foot-actuated
- Planetary final drives
- Power-assisted hydraulic service brakes (conform to ISO 3450): Inboard, wet multi-disc, self-adjusting and self-equalizing
- Full-power hydraulic service brakes (conform to ISO 3450): Inboard, wet multi-disc, self-adjusting and self-equalizing
- Parking/emergency brake with electric switch control (conforms to ISO 3450): Spring applied, hydraulically released wet multi-disc / Independent of service brakes
- Hydrostatic power steering with emergency manual mode
- ▲ ▲ ▲ Non-powered front axle
- Mechanical-front-wheel drive with open differential: Electric on/off control / Sealed axle
- Mechanical-front-wheel drive with traction control limited-slip differential: Electric on/off control / Sealed axle
- ▲ ▲ ▲ Rear wheel spacers for use with chains
- ▲ ▲ ▲ MFWD driveshaft guard

Backhoe

- Standard dipperstick, 4.34-m (14 ft. 3 in.) digging depth
- Standard dipperstick, 4.42-m (14 ft. 6 in.) digging depth
- Standard dipperstick, 4.83-m (15 ft. 10 in.) digging depth
- Standard dipperstick, 5.44-m (17 ft. 10 in.) digging depth
- ▲ ▲ Extendable dipperstick, 1.07-m (3 ft. 6 in.) extension
- ▲ Extendable dipperstick, 1.22-m (4 ft.) extension
- ▲ Extendable dipperstick, 1.37-m (4 ft. 6 in.) extension
- Heavy-duty backhoe bucket cylinder option
- ▲ 2-lever (Deere) backhoe controls
- ▲ 2-lever pilot controls with pattern-selection feature
- Backhoe transport lock lever
- Swing lock pin stored in operator's station
- Stabilizers with 2-direction anti-drift valves
- Pivoting stabilizers with reversible pads
- ▲ Extended (long) stabilizers with reversible pads
- Less bucket, with bucket pins
- ▲ ▲ ▲ Standard-duty backhoe bucket with lift loops

310J 310SJ 410J 710J Backhoe (continued)

- ▲ ▲ ▲ Heavy-duty backhoe bucket with lift loops
- ▲ ▲ ▲ Severe-duty backhoe bucket with lift loops
- ▲ ▲ ▲ Backhoe coupler for "C," "D," "E," "G," and "J" Series John Deere, Case, and Cat buckets
- ▲ ▲ ▲ Auxiliary backhoe valve for swingers, thumbs, etc. with auxiliary plumbing
- ▲ ▲ ▲ Auxiliary backhoe valve for hammers and compactors with auxiliary plumbing
- ▲ ▲ ▲ Hydraulic thumb

Loader†

- Loader bucket anti-spill (rollback)
- Return-to-dig feature
- Single-lever control with electric clutch cutoff switch
- Bucket-level indicator
- Loader boom service lock
- ▲ ▲ ▲ Auxiliary loader hydraulics with 2-lever control
- ▲ ▲ ▲ Hydraulic coupler for buckets, forks, etc.
- Less bucket, with bucket pins
- High-visibility loader arms

Hydraulic System

- 106-L/min. (28 gpm) gear pump, open center system
- 136-L/min. (36 gpm) tandem gear pump, open-center system
- 159-L/min. (42 gpm) axial piston pump, PCLS system
- 197-L/min. (52 gpm) axial piston pump, PCLS system
- Independent hydraulic reservoir
- "O"-ring face seal connectors
- 6-micron vertical spin-on filter

Electrical System

- 12-volt system
- 90-amp alternator
- Single battery with 190-min. reserve capacity and 950 CCA
- ▲ ▲ ▲ Dual batteries with 380-min. reserve capacity and 1,900 CCA
- Positive terminal battery cover
- Blade-type multi-fused circuits
- By-pass start safety cover on starter
- ▲ ▲ ▲ Master disconnect switch
- Jump/auxiliary start terminal

Lights

- ● ● Halogen lights (4), 32,500 candlepower each (2 front driving/working and 2 rear working)
- Turn signal/flashing (2 front and 2 rear)
- Rear stop and tail (2)
- Rear reflectors (2)

Operator's Station

- ● ● Modular-design ROPS/FOPS canopy with molded roof (conforms to SAE J1040): Isolation mounted
- Left and right access
- Slip-resistant steps and ergonomically located handholds (conform to SAE J185)
- Molded floor mats
- Headliner
- Coat hook
- 12-volt outlets (2 cab, 1 canopy)
- Built-in beverage and Thermo bottle holders
- Built-in Operator's Manual storage compartment with manual
- Interior rearview mirror
- Interior front-view mirror
- Outside rearview mirrors
- Rotary hand throttle
- Suspended foot throttle
- Horn
- Seat belt, 76-mm (3 in.), with retractor
- Key start switch with electric fuel shutoff
- ▲ ▲ ▲ Electronic anti-theft enabled through monitor
- Engine coolant temperature gauge, illuminated electronic, with audible warning
- Oil temperature gauge, illuminated electronic, with audible warning

310J 310SJ 410J 710J Operator's Station (continued)

- ● ● Fuel gauge, illuminated electronic
- ● ● Digital display of engine hours, engine rpm, and system voltage
- ● ● Monitor system with audible and visual warnings: Engine air restriction indicator / Low alternator voltage indicator / Engine oil pressure indicator with audible warning / Hydraulic filter restriction indicator / Parking brake on/off indicator with audible warning / Seat belt indicator / Low brake pressure / Machine diagnostic information via 4-push-button/LCD operator interface
- ● ● **Basic Canopy:** Mechanical suspension deluxe vinyl swivel seat with lumbar adjustment and armrests (fully adjustable)
- ● ● **Canopy:** Mechanical suspension deluxe vinyl swivel seat with lumbar adjustment and armrests (fully adjustable) / Tilt steering, infinitely adjustable / Additional halogen work lights (6), 32,500 candlepower each (2 front, 2 rear, and 2 side docking)
- ● ● **Basic Cab:** Air-suspension deluxe fabric swivel seat with lumbar adjustment / Air conditioner (7.6-kW [26,000 Btu/hr.] output and CFC-free R134a refrigerant)
- ● ● **Premium Cab:** Air-suspension deluxe fabric swivel seat with lumbar adjustment / Tilt steering, infinitely adjustable / AM/FM/weather-band radio / Sun visor / Headliner, dome light, left and right cab doors, tinted safety glass, windshield wiper (1 rear and 1 front), front windshield washer, fresh-air intake, and heater/defroster/pressurizer (11.7-kW [40,000 Btu/hr.] heater) / Additional halogen work lights (6), 32,500 candlepower each (2 front, 2 rear, and 2 side docking)
- ● ● **Ultimate Cab:** Air-suspension deluxe fabric swivel seat with lumbar adjustment / Tilt steering, infinitely adjustable / AM/FM/weather-band radio with CD player / Sun visor / Headliner, dome light, left and right cab doors, tinted safety glass, windshield wiper (1 rear and 1 front), front windshield washer, fresh-air intake, and heater/defroster/pressurizer (11.7-kW [40,000 Btu/hr.] heater) / Additional halogen work lights (6), 32,500 candlepower each (2 front, 2 rear, and 2 side docking) / Air conditioner (7.6-kW [26,000 Btu/hr.] output and CFC-free R134a refrigerant) / Ride control

Overall Vehicle

- ● ● 1-piece unitized construction mainframe
- ● ● Vehicle tie-downs (2 front and 2 rear)
- Remote grease bank for front axle
- Front cover
- ▲ ▲ ▲ Heavy-duty front bumper
- ▲ ▲ ▲ 204-kg (450 lb.) front counterweight
- ▲ ▲ ▲ 317-kg (700 lb.) front counterweight
- ▲ ▲ ▲ 454-kg (1,000 lb.) front counterweight
- ▲ ▲ ▲ 567-kg (1,250 lb.) front counterweight
- ▲ ▲ ▲ 657-kg (1,450 lb.) front counterweight
- 422-kg (930 lb.) front counterweight
- ▲ 740-kg (1,630 lb.) front counterweight
- Rubber grille bumpers
- Fuel tank, 155 L (41 gal.), ground-level fueling
- Fuel tank, 261 L (69 gal.), ground-level fueling
- 2-position easy-tilt hood
- Extended grille frame
- Removable toolbox with padlock hasp
- Vandal protection for locking monitor, engine hood, toolbox, hydraulic reservoir, and fuel tank
- Reverse warning alarm
- Sound-reduction package
- Dent-resistant full-coverage rear fenders
- Boom-protection plate
- ▲ ▲ ▲ JDLink™ wireless communication system (available in specific countries; see your dealer for details)

†See dealer for range of heavy-duty, multipurpose, and coupler buckets and forks.

Net engine power is with standard equipment including air cleaner, exhaust system, alternator, and cooling fan at test conditions specified per ISO9249. No derating is required up to 1500-m (5,000 ft.) altitude for the 310J and up to 3050-m (10,000 ft.) for the 310J with optional altitude-compensating turbocharger, the 310SJ, the 410J, and the 710J.

Specifications and design are subject to change without notice. Wherever applicable, specifications are in accordance with ISO standards. Except where otherwise noted, these specifications are based on a 310J unit with 19.5L-24-in. 10PR (R4) tubeless rear and 11L-16-in. 12PR (F3) front tires, 0.76-m³ (1.00 cu. yd.) loader bucket, and 610-mm x 0.18-m² (24 in. x 6.5 cu. ft.) backhoe bucket; a 310SJ unit with 19.5L-24-in. 10PR (R4) tubeless rear and 11L-16-in. 12PR (F3) front tires, 0.86-m³ (1.12 cu. yd.) loader bucket, and 610-mm x 0.21-m² (24 in. x 7.5 cu. ft.) backhoe bucket; a 410J unit with 19.5L-24-in. 10PR (R4) tubeless rear and 11L-16-in. 12PR (F3) front tires, 1.00-m³ (1.30 cu. yd.) loader bucket, and 610-mm x 0.21-m² (24 in. x 7.5 cu. ft.) backhoe bucket; and a 710J unit with 21L-28 R-4 (14) rear and 14.5/75-16.1 SL F-3 (10) front tires, 1.24-m³ (1.62 cu. yd.) loader bucket, and 610-mm x 0.31-m² (24 in. x 11.1 cu. ft.) backhoe bucket.

310SJ / 410J WITH TOTAL MACHINE CONTROL™

Key: ● Standard equipment ▲ Optional equipment

*See your John Deere dealer for further information.

310SJ 410J TMC TMC Engine

- ● Meets EPA Tier 3/EU Stage IIIA emissions
- ● John Deere Model 4045HT054 – 4.5 liter, 70 kW (94 net peak hp) turbocharged, isolation mounted
- ● John Deere Model 4045HT054 – 4.5 liter, 73 kW (98 net peak hp) turbocharged, isolation mounted
- ● Vertical spin-on engine oil filter
- ● Vertical spin-on fuel filter with water separator
- ● Oil-to-water engine oil cooler
- ● Antifreeze, -37°C (-34°F)
- ● Coolant recovery tank
- ● Serpentine belt with automatic belt tensioner
- ● Suction-type cooling fan
- ● Enclosed safety fan guard
- ▲ ▲ High ambient temperature engine cooling
- ● Dual-element dry-type air cleaner
- ● Muffler, under hood with curved-end exhaust stack
- ▲ ▲ Chrome exhaust extension
- ▲ ▲ Cold-start package – electric ether starting aid and engine coolant heater, 1,000 watts

Powertrain

- ● PowerShift™ transmission: Torque converter with electrically actuated twist grip F-N-R with neutral safety switch interlock (1st through 4th gears)
- ● Transmission oil cooler
- ● Vertical spin-on transmission filter
- ● Transmission remote oil-sampling port
- ● Differential lock, electric foot-actuated
- ● Planetary final drives
- ● Power-assisted hydraulic service brakes (conform to ISO 3450): Inboard, wet multi-disc, self-adjusting and self-equalizing
- ● Parking/emergency brake with electric switch control (conforms to ISO 3450): Spring applied, hydraulically released wet multi-disc / Independent of service brakes
- ● Hydrostatic power steering with emergency manual mode
- ● Mechanical-front-wheel drive with traction control limited-slip differential: Electric on/off control / Sealed axle
- ▲ ▲ Rear wheel spacers for use with chains
- ▲ ▲ MFWD driveshaft guard

Backhoe

- ● Extendable dipperstick, 1.07-m (3 ft. 6 in.) extension
- ● Extendable dipperstick, 1.22-m (4 ft.) extension
- ● Heavy-duty backhoe bucket cylinder
- ● Backhoe transport lock lever
- ● Swing lock pin stored in operator's station
- ● Stabilizers with 2-direction anti-drift valves
- ● Pivoting stabilizers with reversible pads
- ● Extended (long) stabilizers with reversible pads
- ● Less bucket, with bucket pins
- ▲ ▲ Standard-duty backhoe bucket with lift loops
- ▲ ▲ Heavy-duty backhoe bucket with lift loops
- ▲ ▲ Severe-duty backhoe bucket with lift loops
- ▲ ▲ Backhoe coupler for "C," "D," "E," "G," and "J" Series John Deere, Case, and Cat buckets
- ● Auxiliary backhoe valve for swingers, thumbs, etc. with auxiliary plumbing
- ● Auxiliary backhoe valve for hammers and compactors with auxiliary plumbing

310SJ 410J TMC TMC Backhoe (continued)

- ▲ ▲ Hydraulic thumb
- ● Loader[†]
- ● Loader bucket anti-spill (settable height)
- ● Return-to-dig feature (settable / activates from curled or dumped bucket position)
- ● Armrest-mounted joysticks with electric clutch cutoff, auxiliary loader control, extendible dipperstick control, MFWD control (momentary), MFWD control (permanent), proportional auxiliary backhoe control, and horn
- ● Auxiliary loader hydraulics with thumb-switch control
- ● Mini joystick for simultaneous control of loader and backhoe
- ● Electric bucket-level indicator
- ● Loader boom service lock
- ● Ride control
- ● Less bucket, with bucket pins
- ● High-visibility loader arms
- ● Tool-carrier loader: Front loader hydraulic quick-coupler / Parallel lift (selectable) / Return-to-carry (selectable / height set) / Boom-height kickout

Hydraulic System

- ● 159-L/min. (42 gpm) axial piston pump
- ● Independent hydraulic reservoir
- ● "O"-ring face seal connectors
- ● 6-micron vertical spin-on filter

Electrical System

- ● 12-volt system
- ● 120-amp alternator
- ● Dual batteries with 380-min. reserve capacity and 1,900 CCA
- ● Dual battery master-disconnect switch
- ● Positive terminal battery cover
- ● Blade-type multi-fused circuits
- ● By-pass start safety cover on starter
- ● Jump/auxiliary start terminal

Lights

- ● Turn signal/flashing (2 front and 2 rear)
- ● Rear stop and tail (2)
- ● Rear reflectors (2)

Operator's Station

- ● Modular-design ROPS/FOPS cab with molded roof (conforms to SAE J1040): Isolation mounted
- ● Left and right access
- ● Slip-resistant steps and ergonomically located handholds (conform to SAE J185)
- ● Molded floor mats
- ● Headliner
- ● Coat hook
- ● 12-volt outlets (2)
- ● Built-in beverage and Thermos bottle holders
- ● Built-in Operator's Manual storage compartment with manual
- ● Auto-idle
- ● Interior rearview mirror
- ● Interior front-view mirror
- ▲ ▲ Outside rearview mirrors
- ● Stabilizer controls in the left armrest
- ● Rotary-dial hand throttle
- ● Suspended foot throttle
- ● Tilt steering, infinitely adjustable

310SJ 410J TMC TMC Operator's Station (continued)

- ● Horn in side console
- ● Seat belt, 76-mm (3 in.), with retractors
- ● Key start switch with electric fuel shutoff
- ● Electronic anti-theft enabled through monitor
- ● Engine coolant temperature gauge, illuminated electronic, with audible warning
- ● Oil temperature gauge, illuminated electronic, with audible warning
- ● Fuel gauge, illuminated electronic
- ● Digital display of engine hours, engine rpm, and system voltage
- ● Monitor system with audible and visual warnings: Engine air restriction indicator / Low alternator voltage indicator / Engine oil pressure indicator with audible warning / Hydraulic filter restriction indicator / Parking brake on/off indicator with audible warning / Seat belt indicator / Low brake pressure / Machine diagnostic information via 4-pushbutton/LCD operator interface
- ● **TMC Canopy:** Air-suspension deluxe vinyl swivel seat with lumbar adjustment and armrests (fully adjustable) / Tilt steering, infinitely adjustable / Additional halogen work lights (6), 32,500 candlepower each (2 front, 2 rear, and 2 side docking)
- ● **Ultimate Cab:** Air-suspension deluxe fabric swivel seat with lumbar adjustment / Tilt steering / AM/FM/weather-band radio with CD player / Sun visor / Headliner, dome light, left and right cab doors, tinted safety glass, windshield wiper (1 rear and 1 front), front windshield wiper, fresh-air intake, and heater/defroster/pressurizer (11.7-kW [40,000 Btu/hr.] heater) / Additional halogen work lights (6), 32,500 candlepower each (2 front, 2 rear, and 2 side docking) / Air conditioner (7.6-kW [26,000 Btu/hr.] output and CFC-free R134a refrigerant)

Overall Vehicle

- ● 1-piece unitized construction mainframe
- ● Vehicle tie-downs (2 front and 2 rear)
- ● Remote grease bank for front axle
- ● Heavy-duty front bumper
- ▲ ▲ 204-kg (450 lb.) front counterweight
- ▲ ▲ 317-kg (700 lb.) front counterweight
- ▲ ▲ 454-kg (1,000 lb.) front counterweight
- ▲ ▲ 567-kg (1,250 lb.) front counterweight
- ▲ ▲ 657-kg (1,450 lb.) front counterweight
- ▲ ▲ Rubber grille bumpers
- ● Fuel tank, 155 L (41 gal.), ground-level fueling
- ● 2-position easy-tilt hood
- ● Extended grille frame
- ● Removable toolbox with padlock hasp
- ● Vandal protection for locking engine hood, toolbox, hydraulic reservoir, and fuel tank
- ● Reverse warning alarm
- ▲ ▲ Sound-reduction package
- ● Dent-resistant full-coverage rear fenders
- ▲ ▲ JDLink™ wireless communication system (available in specific countries; see your dealer for details)

[†]See dealer for range of heavy-duty, multipurpose, and coupler buckets and forks.

Net engine power is with standard equipment including air cleaner, exhaust system, alternator, and cooling fan at test conditions specified per ISO9249. No derating is required up to 10,000-ft. (3050 m).

Specifications and design are subject to change without notice. Wherever applicable, specifications are in accordance with ISO standards. Except where otherwise noted, these specifications are based on a 310SJ TMC unit with 19.5L-24-in. 10PR (R4) tubeless rear and 11L-16-in. 12PR (F3) front tires, 1.12-cu.-yd. (0.86 m³) loader bucket, and 24-in. x 7.5-cu.-ft. (610 mm x 0.21 m³) backhoe bucket; and a 410J TMC unit with 19.5L-24-in. 10PR (R4) tubeless rear and 11L-16-in. 12PR (F3) front tires, 1.30-cu.-yd. (1.00 m³) loader bucket, and 24-in. x 7.5-cu.-ft. (610 mm x 0.21 m³) backhoe bucket.



JOHN DEERE

www.JohnDeere.com

