

7 0 - 9 9 N E T H O R S E P O W E R



JOHN DEERE

J

DOZERS

450J | 550J | 650J





650J

90 hp LT and XLT
99 hp LGP
18,560 lb. LT
18,600 lb. XLT
19,750 lb. LGP
18-, 20-, 24-, and 28-in. grousers
105-, 115-, and 128-in. blades

Push productivity

Often imitated but never duplicated, John Deere dozers continue to set the standard for operator control and productivity. Backed by 30 years of hydrostatic experience, their unique state-of-the-art Total Machine Control (TMC) enables an operator to customize machine operation and response to

personal preferences. Coupled with an uncommonly smooth full-featured hydrostatic transmission, the J-Series deliver unsurpassed productivity, uptime, and daily operating costs. That's for starters. Read on and learn more about all of the J-Series Dozers' many productivity- and uptime-boosting advantages.

550J

80 hp LT
84 hp LGP
17,016 lb. LT
18,252 lb. LGP
18- and 24-in. grousers
105-, 115-, and 128-in. blades

450J

70 hp LT; 74 hp LGP
16,283 lb. LT
17,525 lb. LGP
16-, and 24-in. grousers
97-, 115-, and 124-in. blades



to the next level.

Operator-favorite speed-in-grip steering and transmission control lever and rotary throttle are standard equipment.

Decelerator lets you choose between slowing travel speed and engine rpm, or travel speed only. For unparalleled low-effort toe-tip control.

Deere's unique TMC lets an operator customize the crawler's operating characteristics and response, and even records machine usage.

Extended service intervals, larger fuel tanks, remote test ports, and diagnostic messaging help maximize uptime and productivity.

Screw-type blade pitch link can be adjusted quickly and easily for top production in varying materials and applications.



Counterrotation is a productivity-boosting feature that enables the operator to overcome heavy corner loads and to quickly reposition the blade on the go. Provides space-saving spot turns, too.



With optional Integrated Grade Control (IGC), your 650J Dozer arrives from the factory "plug and play" ready. Its open architecture design lets you employ the electronic grade-control system that's right for you.



These dozers steer the same and maintain their preset speed whether they're on level ground or a 2-to-1 slope. For total control regardless of the terrain.

Uncommon control, uncompromising results.

Others may offer hydrostatic drivetrains in their dozers. But no other dozer even comes close to delivering the proven performance and exceptionally smooth control you get with the 450J, 550J, or 650J. Power turns, counterrotation, infinitely variable travel speeds – the J-Series'

enhanced state-of-the-art controls put you in complete command of a whole arsenal of highly productive hydrostatic advantages. No wonder John Deere finish dozers have become owner and operator favorites. And why they continue to deliver industry-leading resale value.

State-of-the-art controls command the full-featured hydrostatic drivetrain and six-way blade, ensuring predictable response at all times, in all conditions.

Power management takes the guesswork out of efficient operation. Simply set maximum desired ground speed and the system maintains peak engine and power efficiency without stalling or shifting.

Infinitely variable travel speeds from standstill to five mph let an operator choose the right speed for the job. Travel-speed range can also be modified for specific applications or terrain conditions, and even limited to maximize undercarriage life.

Blade ratio and center of gravity are optimized, giving these dozers the balance needed for superior grade work.

TMC allows maximum flexibility and control, letting you customize machine operation to personal preferences.



Infinitely variable control lets an operator speed up or slow power to each track, for smooth, full-power turns.

The fully modulated drivetrain ensures smooth starts and direction changes—virtually eliminating jerky and abrupt movements.



Get more done within our comfort zone.

Generous hydraulic flow and precise metering deliver a natural "feel" to the T-bar control that will enhance any operator's grading skills. Blade response is powerful and quick.

Retractable seat belt, slip-resistant floor mat, convenient grab bars, neutral-start lever, and automatic park brake help keep the operator out of harm's way.

Deluxe-suspension armchair adjusts seven ways for daylong comfort and support. Adjustable armrests and footrests are standard.

Single lever provides low-effort control of steering, forward/reverse travel, and ground speed. It's also detented so it doesn't require an operator's constant touch or attention and employs a thumb-actuated travel-speed switch.

Convenient 12-volt port provides power for cell phones and other accessories.

Want your operators to be more productive? Put them in the seat of this spacious air-conditioned cab. From their ergonomically designed fully customizable controls to best-in-class visibility, J-Series Dozers are loaded with everything you need to keep your operators calm, cool, productive – and on the payroll.



Cab-forward design positions the operator for a more stable ride and a commanding view behind, below, and beyond the blade. Monitor keeps a vigilant watch on vital functions and issues visual or audible warnings.



Exclusive TMC lets you customize decelerator mode and response, forward/reverse ground-speed ranges, steering modulation, FNR shift rate, and forward/reverse speed ratios, for unsurpassed control.



Choose the decelerator function that's right for the job. Slow both ground speed and engine rpm, or ground speed only to help maintain traction without affecting engine power and hydraulic response. Fully depressing the pedal applies the brakes.



Automotive-type directional vents deliver warm or cool air with quiet efficiency. Air conditioning is standard in all cabs. For non-cab crawlers, an optional under-seat heater warms the operator.



High-intensity halogen driving lights are standard. Or opt for the factory-installed 360-degree light package that delivers superior illumination.

Engine, hydrostatic pumps, and hydraulic pump are bolted to a subframe, forming an easy-to-remove powertrain package. It's attached to the mainframe on rubber mounts to isolate vibration and reduce noise.

One-piece robot-welded mainframe resists torsional stress, absorbs shock loads, and delivers maximum strength while providing easy service access to major drivetrain components.

Wet sleeve liners provide uniform engine cooling and longer durability than cast-in-block designs.

Heavy-duty high-pressure hoses connect the pumps and motors that form the drivetrain. O-ring face-seal couplings virtually eliminate leaks.

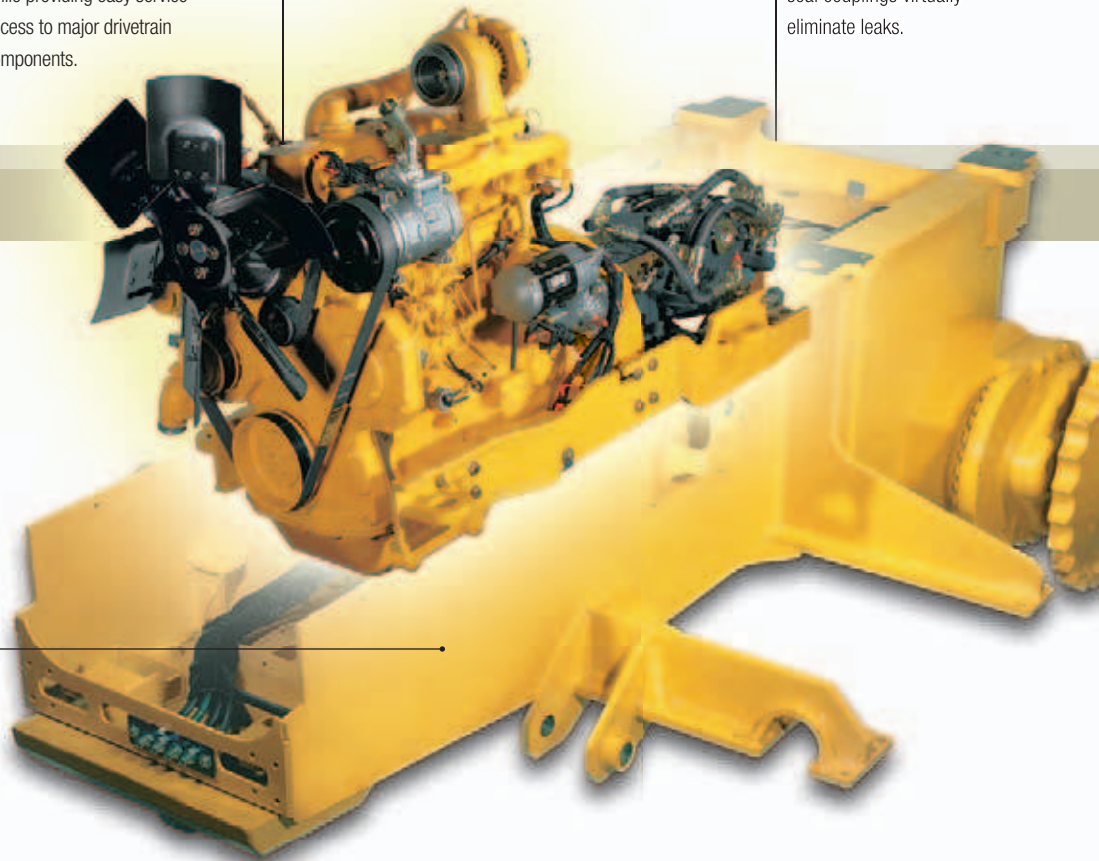

Nothing runs like a Deere, because nothing is built like one.

Designed and built with state-of-the-art tools and techniques by a quality-conscious workforce at our world-class facility in Dubuque, Iowa, Deere dozers deliver unsurpassed reliability and uptime.

But don't just take our word for it. Perhaps the best way to know what you can expect out of one is to see what goes into it. When you learn how they're built, you'll run a Deere.

Heavy-duty triple-reduction final drives are attached to the mainframe, isolating them from track-imposed shock loads. Seal guards are built in, not extra cost.

Sealed transmission electrical connectors with gold-plated pins prevent moisture and contaminants from entering terminals for increased reliability.

Heavy-duty undercarriage is sealed, lubricated, and built to last. Available extended life undercarriage delivers twice the bushing life, even in extremely abrasive conditions. If you're looking to further reduce maintenance and operating costs, the SC-2™ option is for you.

Standard features such as bypass start protection, automatic park brake, convenient handholds, and slip-resistant steps help keep the operator out of harm's way.

Closed-cell blade design and robot-welded, fabricated, box-section C-frame is strong and durable. Heavy-duty ball-and-socket joint resists material build-up for long-term grading precision.



Large fuel tanks and 500-hour engine oil service intervals let you run longer between fill-ups and maintenance.

The bucks stop here.

Hinged side shields open wide and provide ground-level access to batteries; master electrical switch; cold-weather-start aid; and vertical transmission, hydraulic, and fuel filters.



Unlike other crawlers that require a laptop computer, an advanced diagnostic monitor gives easy-to-understand messages.



Serpentine belt never needs adjusting. 500-hour service interval lets you go longer between engine oil changes.



Conveniently located easy-to-read sight gauge lets you check hydraulic-fluid levels at a glance.



Remote drive system test ports help speed troubleshooting for increased uptime and productivity.

If there's a way to reduce your daily operating costs and simplify maintenance, we've incorporated it into the J-Series Dozers. Service intervals have been extended, and same-side service points help make quick work of the daily routine. Lockable doors swing open wide, providing quick

and ample access to dipsticks, vertical spin-on filters, sight gauges, and maintenance-free batteries. These and other timesaving features such as an easy-to-clean undercarriage, quick-to-replace hydraulic hoses, and designed-in diagnostics minimize downtime and expense.



With JDLink™, you'll know exactly where your dozer is and how it's performing. This optional wireless communication system delivers location, utilization, performance, and maintenance data to your computer. Helps increase productivity and uptime, and lower operating costs.

Hydraulic and hydrostatic reservoirs are completely separated, eliminating any possibility of cross-contamination.

Check or add to engine oil and coolant levels or change the air filter through a large door atop the hood.

Vertical filters allow quick, no-spill changes. Engine, hydraulics, and transmission utilize a common oil, further simplifying service.

Lube bank puts difficult-to-grease C-frame pivots within easy reach. Periodic maintenance and lube chart ensures that nothing gets overlooked.



Specifications

Engine	450J LT	450J LGP
Manufacturer and Model	John Deere 4045T	John Deere 4045T
Non-Road Emission Standards	certified to EPA Tier 2 emissions	certified to EPA Tier 2 emissions
Cylinders	4	4
Displacement	276 cu. in. (4.5 L)	276 cu. in. (4.5 L)
Net Peak Power (ISO9249)	70 hp (52 kW) @ 2,200 rpm	74 hp (55 kW) @ 2,200 rpm
Net Peak Torque (ISO9249)	234 lb.-ft. (318 Nm) @ 1,200 rpm	251 lb.-ft. (341 Nm) @ 1,200 rpm
Aspiration	altitude-compensating turbocharger	altitude-compensating turbocharger
Lubrication	pressure system with full-flow spin-on filter and oil-to-water cooler	pressure system with full-flow spin-on filter and oil-to-water cooler
Air Cleaner	dual safety element dry type, evacuator valve	dual safety element dry type, evacuator valve
Slope Operation (maximum angle)	45 deg.	45 deg.

Cooling	450J LT / 450J LGP
Blower-type cooling fan	
Engine Coolant Rating	-34 deg. F (-37 deg. C)

Powertrain	
Transmission	dual-path, electronic-controlled, hydrostatic drive; load-sensing, automatically adjusts speed and power to match changing load conditions; each track is powered by a variable-displacement piston pump and two-speed motor combination; decelerator controls speed
Travel Speeds (forward and reverse)	5.0 mph (8.0 km/h)
Steering	single-lever steering, direction control, and counterrotation; full power turns and infinitely variable track speeds provide unlimited maneuverability and optimum control; hydrostatic steering eliminates steering clutches and brakes
Final Drives	heavy-duty triple-reduction final drives attach directly to the mainframe; isolated from track and dozer frame loads
Brakes	hydrostatic (dynamic) braking stops the machine whenever the direction-control lever is moved to neutral or whenever the decelerator is depressed to the detent
Service Brakes	hydrostatic braking when direction-control lever is moved to neutral or when the decelerator is depressed to the detent
Parking Brakes	wet, multi-disc applied automatically when engine stops, when decelerator pedal depressed to brake position, when unit is in neutral for three seconds with detected motion, or when the park lock lever is in park position; machine cannot be driven with brake applied

Hydraulics	
Open-center hydraulic system with gear pump	
Pump Flow	15 gpm (56.8 L/min.) @ 2,200 rpm
System Relief Pressure	3,000 psi (20 684 kPa)
Controls	three-function hydraulic valve with low-effort single-lever T-bar

Electrical	
Voltage	12 volt
Battery Capacity	950 CCA
Reserve Capacity	190 min.
Alternator Rating	65 amp
Lights	3 total: grille mounted (2) and rear mounted (1), and rear reflectors (2)

Undercarriage	450J LT	450J LGP
Tracks	John Deere Dura-Trax™, deep-heat-treated, pins and bushings sealed for life; rollers and idlers permanently sealed and lubricated	John Deere Dura-Trax, deep-heat-treated, pins and bushings sealed for life; rollers and idlers permanently sealed and lubricated
Track Gauge (standard)	4 ft. 9 in. (1448 mm)	5 ft. 5 in. (1651 mm)
Grouser Width (closed center, single bar)	16 in. (406 mm)	24 in. (610 mm)
Chain	sealed and lubricated	sealed and lubricated
Shoes (each side)	40	40
Track Rollers (single flange, each side)	6	6
Track Length on Ground	7 ft. 2 in. (2184 mm)	7 ft. 2 in. (2184 mm)
Ground Contact Area	2,752 sq. in. (17 755 cm ²)	4,128 sq. in. (26 632 cm ²)
Ground Pressure	5.9 psi (40.7 kPa)	4.3 psi (29.3 kPa)
Ground Clearance with Single-Bar Grouser (excluding grouser height)	13.6 in. (345 mm)	13.6 in. (345 mm)
Track Pitch	6.29 in. (160 mm)	6.29 in. (160 mm)

Serviceability	450J LT / 450J LGP
Refill Capacities*	
Fuel Tank	47 gal. (178 L)
Cooling System with Recovery Tank	17 qt. (16 L)
Engine Oil with Filter	15 qt. (14 L)
Transmission Reservoir with Filter	11.3 gal. (43 L)
Final Drive (each)	7 qt. (6.6 L)
Hydraulic Reservoir and Filter	8.5 gal. (32.2 L)
<i>*Please follow drain and refill procedures and volumes listed in the operator's manual.</i>	

Operating Weights	450J LT	450J LGP
With Standard Equipment, ROPS, Full Fuel Tank, and 175-lb. (79 kg) Operator		
97-in. (2464 mm) Blade and 16-in. (406 mm) Track Shoes	16,283 lb. (7386 kg)	
124-in. (3150 mm) Blade and 24-in. (610 mm) Track Shoes		17,525 lb. (7949 kg)
Optional Components		
Rock Guards (4)	257 lb. (117 kg)	288 lb. (131 kg)
Cab	675 lb. (306 kg)	675 lb. (306 kg)
Counterweight		
Rear (each)	330 lb. (150 kg)	330 lb. (150 kg)
Front (each)	240 lb. (109 kg)	240 lb. (109 kg)
Retrieval Hitch	50 lb. (23 kg)	50 lb. (23 kg)
Extended Drawbar	72 lb. (33 kg)	72 lb. (33 kg)
Limb Risers	229 lb. (104 kg)	229 lb. (104 kg)
Screens		
Rear	76 lb. (34 kg)	76 lb. (34 kg)
Side	94 lb. (43 kg)	94 lb. (43 kg)
Front and Doors	179 lb. (81 kg)	179 lb. (81 kg)
Winch		
4000S	1,437 lb. (652 kg)	1,437 lb. (652 kg)
Fairlead, Four Roller	187 lb. (85 kg)	187 lb. (85 kg)
Ripper, Parallelogram	850 lb. (386 kg)	850 lb. (386 kg)
97-in. (2464 mm) Blade, All-Hydraulic Heavy-Duty C Frame	96 lb. (44 kg)	
115-in. (2921 mm) Blade, All-Hydraulic Heavy-Duty C Frame (adjust to base weight)		5 lb. (2 kg)
All-Hydraulic Heavy-Duty C Frame (less blade, adjust to base weight)	- 1,063 lb. (- 482 kg)	- 1,063 lb. (- 482 kg)

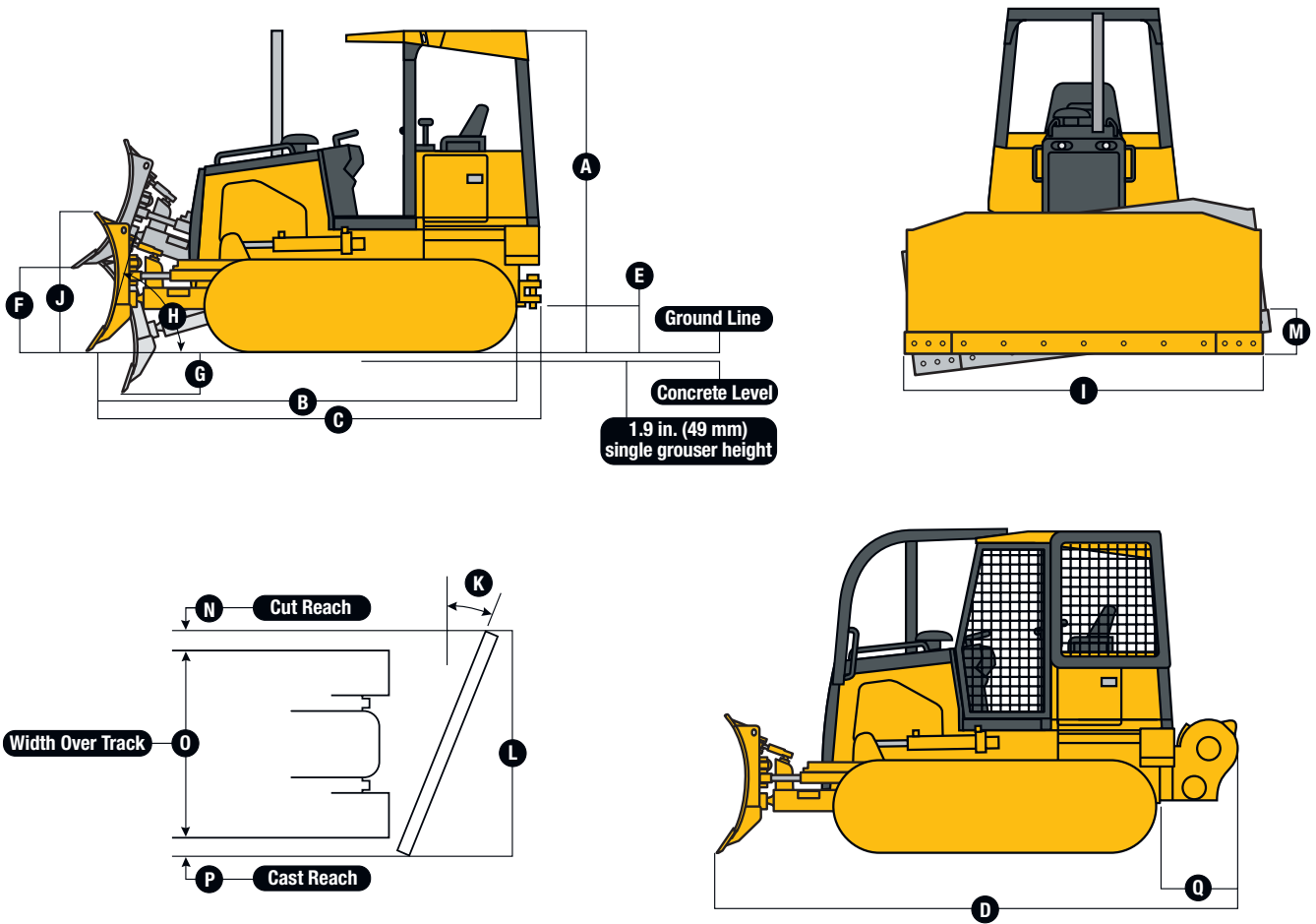

Machine Dimensions

450J LT

450J LGP

A Overall Height (ROPS or cab)	9 ft. 0 in. (2.74 m)	9 ft. 0 in. (2.74 m)
Height of Grousers	1.9 in. (48.3 mm)	1.9 in. (48 mm)
B Overall Length	12 ft. 11 in. (3.94 m)	13 ft. 2 in. (4013 mm)
C Overall Length with Extended Drawbar	13 ft. 6 in. (4.11 m)	13 ft. 4 in. (4064 mm)
D Overall Length with Winch	14 ft. 9 in. (4.50 m)	14 ft. 9 in. (4496 mm)
E Minimum Ground Clearance	13.6 in. (345 mm)	13.6 in. (345 mm)
F Blade Lift Height	30.4 in. (772 mm)	30.4 in. (772 mm)
G Blade Digging Depth	20.8 in. (528 mm)	20.8 in. (528 mm)
H Blade Cutting Edge Angle, Adjustable	52 to 60 deg.	52 to 60 deg.

Forestry Application

450J LT / 450J LGP

Available limb risers and screens for the rollover protective structure, John Deere-built, self-contained 4000S Winch* for versatile skidding and clearing operations

D Overall Length with Winch**	14 ft. 9 in. (4496 mm)
Q 4000S Winch Length	30 in. (752 mm)

*Reference 4000S Winch spec sheet.
**See above for related dimensions.

Blade Specs

450J LT

450J LGP

I Width	97 in. (2464 mm)
J Height	3 ft. 2 in. (955 mm)
SAE Capacity	2.14 cu. yd. (1.64 m ³)
K Blade Angle	25.4 deg.
L Angled Width	7 ft. 4 in. (2225 mm)
M Tilt	13.3 in. (338 mm)
N Cut Reach	2.2 in. (56 mm)
O Width Over Track	6 ft. 1 in. (1854 mm)
P Cast Reach	12.5 in. (318 mm)

115 in. (2921 mm)
3 ft. 2 in. (955 mm)
2.57 cu. yd. (1.96 m ³)
25.4 deg.
8 ft. 8 in. (2639 mm)
15.7 in. (399 mm)
2.3 in. (58.4 mm)
7 ft. 5 in. (2261 mm)
12.6 in. (320 mm)

I Width	115 in. (2921 mm)
J Height	3 ft. 2 in. (955 mm)
SAE Capacity	2.57 cu. yd. (1.96 m ³)
K Blade Angle	25.4 deg.
L Angled Width	8 ft. 8 in. (2639 mm)
M Tilt	15.7 in. (399 mm)
N Cut Reach	10.3 in. (262 mm)
O Width Over Track	6 ft. 1 in. (1854 mm)
P Cast Reach	20.6 in. (523 mm)

124 in. (3150 mm)
2 ft. 11 in. (894.1 mm)
2.46 cu. yd. (1.88 m ³)
25.4 deg.
9 ft. 4 in. (2845 mm)
16.9 in. (429 mm)
6.4 in. (163 mm)
7 ft. 5 in. (2261 mm)
17 in. (424 mm)

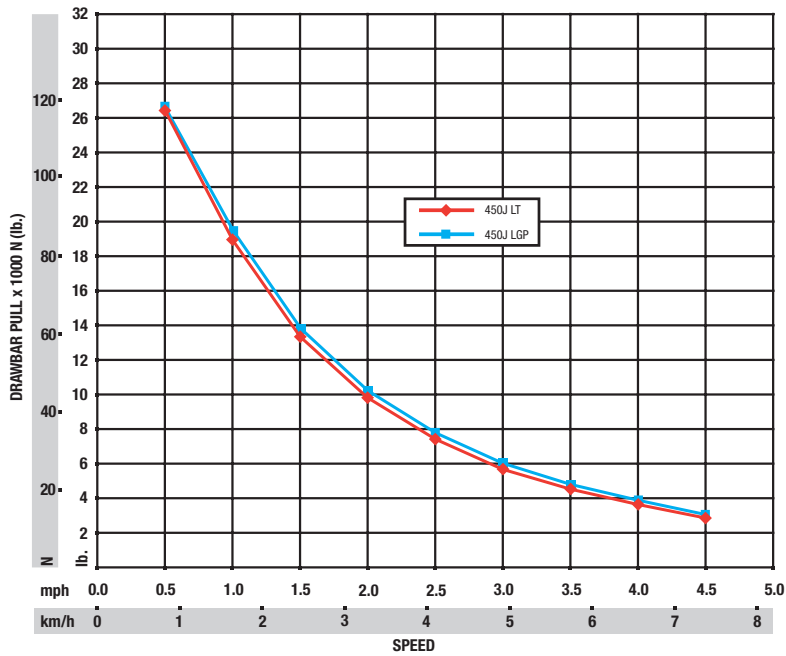

Specifications

Engine	550J LT	550J LGP
Manufacturer and Model	John Deere 4045T	John Deere 4045T
Non-Road Emission Standards	certified to EPA Tier 2 emissions	certified to EPA Tier 2 emissions
Cylinders	4	4
Displacement	276 cu. in. (4.5 L)	276 cu. in. (4.5 L)
Net Peak Power (ISO9249)	80 hp (60 kW) @ 2,200 rpm	84 hp (63 kW) @ 2,200 rpm
Net Peak Torque (ISO9249)	263 lb.-ft. (358 Nm) @ 1,200 rpm	276 lb.-ft. (375 Nm) @ 1,200 rpm
Aspiration	altitude-compensating turbocharger	altitude-compensating turbocharger
Lubrication	pressure system with full-flow spin-on filter and oil-to-water cooler	pressure system with full-flow spin-on filter and oil-to-water cooler
Air Cleaner	dual safety element dry type, evacuator valve	dual safety element dry type, evacuator valve
Slope Operation (maximum angle)	45 deg.	45 deg.

Cooling	550J LT / 550J LGP
Blower-type cooling fan	
Engine Coolant Rating	-34 deg. F (-37 deg. C)

Powertrain	
Transmission	dual-path, electronic-controlled, hydrostatic drive; load-sensing, automatically adjusts speed and power to match changing load conditions; each track is powered by a variable-displacement piston pump and two-speed motor combination; decelerator controls speed
Travel Speeds (forward and reverse)	5.0 mph (8.0 km/h)
Steering	single-lever steering, direction control, and counterrotation; full power turns and infinitely variable track speeds provide unlimited maneuverability and optimum control; hydrostatic steering eliminates steering clutches and brakes
Final Drives	heavy-duty triple-reduction final drives attach directly to the mainframe; isolated from track and dozer frame loads
Brakes	hydrostatic (dynamic) braking stops the machine whenever the direction-control lever is moved to neutral or whenever the decelerator is depressed to the detent
Service Brakes	hydrostatic braking when direction-control lever is moved to neutral or when the decelerator is depressed to the detent
Parking Brakes	wet, multi-disc applied automatically when engine stops, when decelerator pedal depressed to brake position, when unit is in neutral for three seconds with detected motion, or when the park lock lever is in park position; machine cannot be driven with brake applied

Hydraulics	
Open-center hydraulic system with gear pump	
Pump Flow	15 gpm (56.8 L/min.) @ 2,200 rpm
System Relief Pressure	3,000 psi (20 684 kPa)
Controls	three-function hydraulic valve with low-effort single-lever T-bar

Electrical	
Voltage	12 volt
Battery Capacity	950 CCA
Reserve Capacity	190 min.
Alternator Rating	65 amp
Lights	3 total: grille mounted (2) and rear mounted (1), and rear reflectors (2)

Undercarriage	550J LT	550J LGP
Tracks	John Deere Dura-Trax, deep-heat-treated, pins and bushings sealed for life; rollers and idlers permanently sealed and lubricated	John Deere Dura-Trax, deep-heat-treated, pins and bushings sealed for life; rollers and idlers permanently sealed and lubricated
Track Gauge (standard)	5 ft. 1 in. (1549 mm)	5 ft. 9 in. (1753 mm)
Grouser Width (closed center, single bar)	18 in. (457 mm)	24 in. (610 mm)
Chain	sealed and lubricated	sealed and lubricated
Shoes (each side)	40	40
Track Rollers (single flange, each side)	6	6
Track Length on Ground	7 ft. 2 in. (2184 mm)	7 ft. 2 in. (2184 mm)
Ground Contact Area	3,096 sq. in. (19 974 cm ²)	4,128 sq. in. (26 632 cm ²)
Ground Pressure	5.5 psi (37.9 kPa)	4.2 psi (29.0 kPa)
Ground Clearance with Single-Bar Grouser (excluding grouser height)	13.6 in. (345 mm)	13.6 in. (345 mm)
Track Pitch	6.29 in. (160 mm)	6.29 in. (160 mm)

Serviceability	550J LT / 550J LGP
Refill Capacities*	
Fuel Tank	47 gal. (178 L)
Cooling System with Recovery Tank	17 qt. (16 L)
Engine Oil with Filter	15 qt. (14 L)
Transmission Reservoir with Filter	11.3 gal. (43 L)
Final Drive (each)	7 qt. (6.6 L)
Hydraulic Reservoir and Filter	8.5 gal. (32.2 L)
<i>*Please follow drain and refill procedures and volumes listed in the operator's manual.</i>	

Operating Weights	550J LT	550J LGP
With Standard Equipment, ROPS, Full Fuel Tank, and 175-lb. (79 kg) Operator		
105-in. (2667 mm) Blade and 18-in. (457 mm) Track Shoes	17,016 lb. (7718 kg)	
128-in. (3251 mm) Blade and 24-in. (610 mm) Track Shoes		18,252 lb. (8279 kg)
Optional Components		
Rock Guards (4)	288 lb. (131 kg)	288 lb. (131 kg)
Cab	675 lb. (306 kg)	675 lb. (306 kg)
Counterweight		
Rear (each)	330 lb. (150 kg)	330 lb. (150 kg)
Front (each)	240 lb. (109 kg)	240 lb. (109 kg)
Retrieval Hitch	50 lb. (23 kg)	50 lb. (23 kg)
Extended Drawbar	72 lb. (33 kg)	72 lb. (33 kg)
Limb Risers	229 lb. (104 kg)	229 lb. (104 kg)
Screens		
Rear	76 lb. (34 kg)	76 lb. (34 kg)
Side	94 lb. (43 kg)	94 lb. (43 kg)
Front and Doors	179 lb. (81 kg)	179 lb. (81 kg)
Winch		
4000S	1,437 lb. (652 kg)	1,437 lb. (652 kg)
Fairlead, Four Roller	187 lb. (85 kg)	187 lb. (85 kg)
Ripper, Parallelogram	850 lb. (386 kg)	850 lb. (386 kg)
97-in. (2464 mm) Blade, All-Hydraulic Heavy-Duty C Frame	- 151 lb. (- 68 kg)	
115-in. (2921 mm) Blade, All-Hydraulic Heavy-Duty C Frame (adjust to base weight)		- 38 lb. (- 17 kg)
121-in. (3073 mm) Blade, All-Hydraulic Heavy-Duty C Frame (adjust to base weight)		22 lb. (10 kg)
All-Hydraulic Heavy-Duty C Frame (less blade, adjust to base weight)	- 1,212 lb. (- 550 kg)	- 1,373 lb. (- 623 kg)

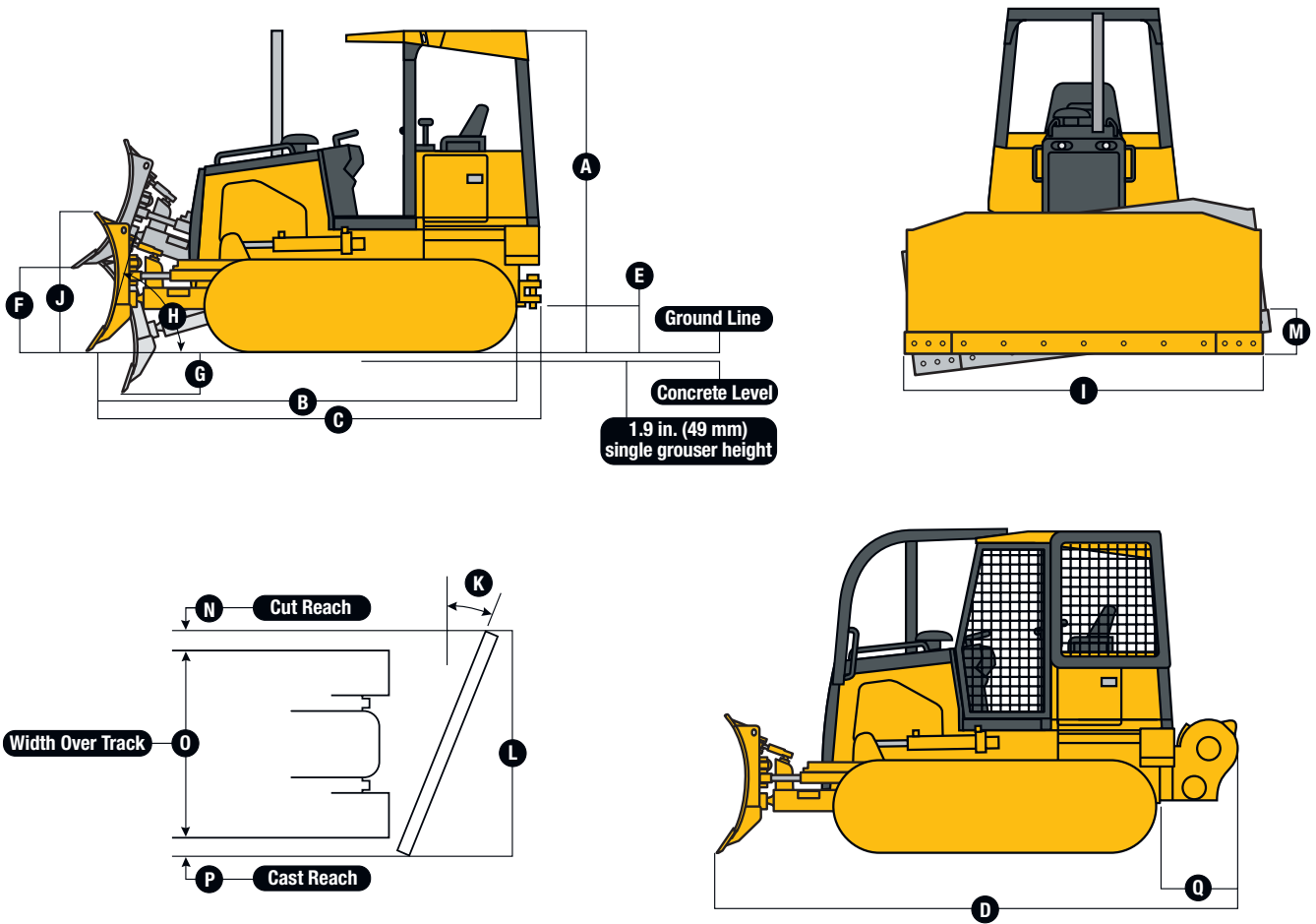

Machine Dimensions

550J LT

550J LGP

A Overall Height (ROPS or cab)	9 ft. 0 in. (2743 mm)	9 ft. 0 in. (2743 mm)
Height of Grousers	1.9 in. (48 mm)	1.9 in. (48 mm)
B Overall Length	13 ft. 3 in. (4039 mm)	13 ft. 3 in. (4039 mm)
C Overall Length with Extended Drawbar	13 ft. 5 in. (4089 mm)	13 ft. 5 in. (4089 mm)
D Overall Length with Winch	14 ft. 11 in. (4547 mm)	14 ft. 11 in. (4547 mm)
E Minimum Ground Clearance	14 in. (345 mm)	14 in. (345 mm)
F Blade Lift Height	31 in. (798 mm)	31 in. (798 mm)
G Blade Digging Depth	21 in. (523 mm)	20.6 in. (523 mm)
H Blade Cutting Edge Angle, Adjustable	52 to 60 deg.	52 to 60 deg.

Forestry Application

550J LT / 550J LGP

Available limb risers and screens for the rollover protective structure, John Deere-built, self-contained 4000S Winch* for versatile skidding and clearing operations

D Overall Length with Winch**	14 ft. 11 in. (4547 mm)
Q 4000S Winch Length	30 in. (752 mm)

*Reference 4000S Winch spec sheet.
**See above for related dimensions.

Blade Specs

550J LT

550J LGP

I Width 105 in. (2667 mm)
J Height 3 ft. 2 in. (955 mm)
 SAE Capacity 2.35 cu. yd. (1.80 m³)
K Blade Angle 22.2 deg.
L Angled Width 8 ft. 1 in. (2469 mm)
M Tilt 14.3 in. (363 mm)
N Cut Reach 4.6 in. (116.84 mm)
O Width Over Track 6 ft. 7 in. (2007 mm)
P Cast Reach 13.6 in. (345 mm)

115 in. (2921 mm)
 3 ft. 2 in. (955 mm)
 2.57 cu. yd. (1.96 m³)
 22.2 deg.
 8 ft. 11 in. (2705 mm)
 15.7 in. (399 mm)
 2.2 in. (56 mm)
 7 ft. 9 in. (2362 mm)
 11 in. (287 mm)

I Width 115 in. (2921 mm)
J Height 3 ft. 2 in. (955 mm)
 SAE Capacity 2.57 cu. yd. (1.96 m³)
K Blade Angle 22.2 deg.
L Angled Width 8 ft. 11 in. (2705 mm)
M Tilt 15.7 in. (399 mm)
N Cut Reach 9.2 in. (233.68 mm)
O Width Over Track 6 ft. 7 in. (2007 mm)
P Cast Reach 18.3 in. (465 mm)

124 in. (3150 mm)
 2 ft. 11 in. (894 mm)
 2.46 cu. yd. (1.88 m³)
 22.2 deg.
 9 ft. 7 in. (2916 mm)
 16.9 in. (429 mm)
 6.4 in. (163 mm)
 7 ft. 9 in. (2362 mm)
 15.4 in. (391 mm)

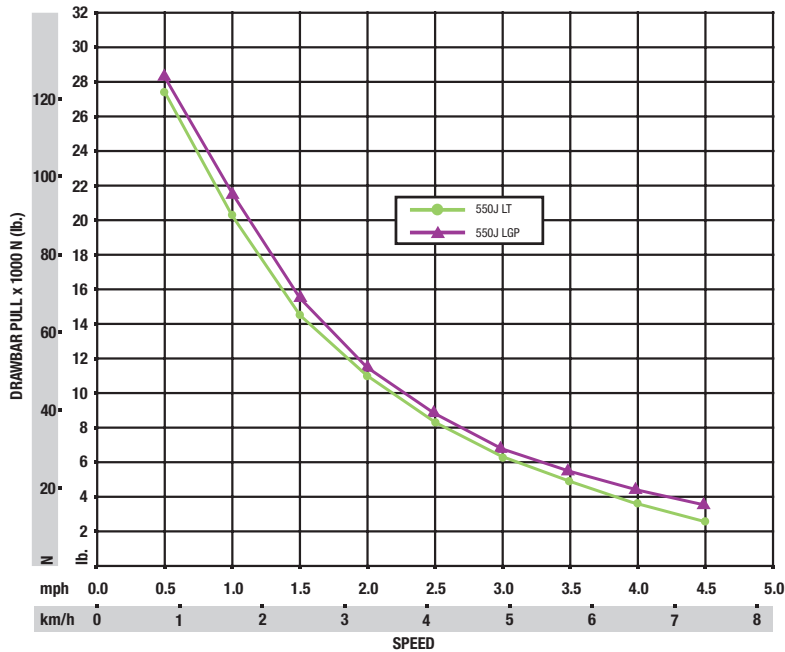

Specifications

Engine	650J LT	650J XLT	650J LGP
Manufacturer and Model	John Deere 4045H	John Deere 4045H	John Deere 4045H
Non-Road Emission Standards	certified to EPA Tier 2 emissions	certified to EPA Tier 2 emissions	certified to EPA Tier 2 emissions
Cylinders	4	4	4
Displacement	276 cu. in. (4.5 L)	276 cu. in. (4.5 L)	276 cu. in. (4.5 L)
Net Peak Power (ISO9249)	90 hp (67 kW) @ 2,200 rpm	90 hp (67 kW) @ 2,200 rpm	99 hp (74 kW) @ 2,200 rpm
Net Peak Torque (ISO9249)	306 lb.-ft. (416 Nm) @ 1,200 rpm	306 lb.-ft. (414 Nm) @ 1,200 rpm	329 lb.-ft. (447 Nm) @ 1,200 rpm
Aspiration	altitude-compensating turbocharger and air-to-air intercooler	altitude-compensating turbocharger and air-to-air intercooler	altitude-compensating turbocharger and air-to-air intercooler
Lubrication	pressure system with full-flow spin-on filter and oil-to-water cooler	pressure system with full-flow spin-on filter and oil-to-water cooler	pressure system with full-flow spin-on filter and oil-to-water cooler
Air Cleaner	dual safety element dry type, evacuator valve	dual safety element dry type, evacuator valve	dual safety element dry type, evacuator valve
Slope Operation (maximum angle)	45 deg.	45 deg.	45 deg.

Cooling	650J LT / 650J XLT / 650J LGP
Blower-type cooling fan	
Engine Coolant Rating	-34 deg. F (-37 deg. C)

Powertrain	
Transmission	dual-path, electronic-controlled, hydrostatic drive; load-sensing, automatically adjusts speed and power to match changing load conditions; each track is powered by a variable-displacement piston pump and two-speed motor combination; decelerator controls speed
Travel Speeds (forward and reverse)	5.0 mph (8.0 km/h)
Steering	single-lever steering, direction control, and counterrotation; full power turns and infinitely variable track speeds provide unlimited maneuverability and optimum control; hydrostatic steering eliminates steering clutches and brakes
Final Drives	heavy-duty triple-reduction final drives attach directly to the mainframe; isolated from track and dozer frame loads
Brakes	hydrostatic (dynamic) braking stops the machine whenever the direction-control lever is moved to neutral or whenever the decelerator is depressed to the detent
Service Brakes	hydrostatic braking when direction-control lever is moved to neutral or when the decelerator is depressed to the detent
Parking Brakes	exclusive safety feature engaged wet, multiple-disc brakes automatically whenever the engine stops, whenever the operator depresses the decelerator pedal to the brake position, whenever the unit is in neutral for three seconds (with detected motion), or whenever the park lock lever is in the park position; machine cannot be driven with brake applied, reducing wear-out or need for adjustment

Hydraulics	
Open-center hydraulic system with gear pump	
Pump Flow	15 gpm (56.8 L/min.) @ 2,200 rpm
System Relief Pressure	3,000 psi (20 684 kPa)
Controls	three-function hydraulic valve with low-effort single-lever T-bar

Electrical	
Voltage	12 volt
Battery Capacity	950 CCA
Reserve Capacity	190 min.
Alternator Rating	65 amp
Lights	3 total: grille mounted (2) and rear mounted (1), and rear reflectors (2)

Undercarriage	650J LT	650J XLT	650J LGP
Tracks	John Deere Dura-Trax, deep-heat-treated, pins and bushings sealed for life; rollers and idlers permanently sealed and lubricated	John Deere Dura-Trax, deep-heat-treated, pins and bushings sealed for life; rollers and idlers permanently sealed and lubricated	John Deere Dura-Trax, deep-heat-treated, pins and bushings sealed for life; rollers and idlers permanently sealed and lubricated
Track Gauge (standard)	5 ft. 1 in. (1549 mm)	5 ft. 1 in. (1549 mm)	5 ft. 9 in. (1753 mm)
Grouser Width (closed center, single bar)	18 in. (457 mm)	18 in. (457 mm)	28 in. (711 mm)
Chain	sealed and lubricated	sealed and lubricated	sealed and lubricated
Shoes (each side)	38	40	40
Track Rollers (single flange, each side)	6	7	7
Track Length on Ground	7 ft. 3 in. (2210 mm)	7 ft. 8 in. (2337 mm)	7 ft. 8 in. (2337 mm)
Ground Contact Area	3,132 sq. in. (20 206 cm ²)	3,312 sq. in. (21 368 cm ²)	5,152 sq. in. (33 239 cm ²)
Ground Pressure	5.9 psi (40.6 kPa)	5.6 psi (38.6 kPa)	3.8 psi (26.2 kPa)
Ground Clearance with Single-Bar Grouser (excluding grouser height)	14.3 in. (363 mm)	14.3 in. (363 mm)	14.3 in. (363 mm)
Track Pitch	6.73 in. (171 mm)	6.73 in. (171 mm)	6.73 in. (171 mm)

Serviceability

Refill Capacities*

Fuel Tank	47 gal. (178 L)
Cooling System with Recovery Tank	17 qt. (16 L)
Engine Oil with Filter	15 qt. (14 L)
Transmission Reservoir with Filter	11.3 gal. (43 L)
Final Drive (each)	7 qt. (6.6 L)
Hydraulic Reservoir and Filter	8.5 gal. (32.2 L)

*Please follow drain and refill procedures and volumes listed in the operator's manual.

Operating Weights

With Standard Equipment, ROPS, Full Fuel Tank, and 175-lb. (79 kg) Operator			
105-in. (2667 mm) Blade and 18-in. (457 mm) Track Shoes	18,560 lb. (8419 kg)	18,600 lb. (8455 kg)	
128-in. (3251 mm) Blade and 28-in. (711 mm) Track Shoes			19,750 lb. (8977 kg)
Optional Components			
Rock Guards (4)	260 lb. (118 kg)	295 lb. (134 kg)	260 lb. (118 kg)
20-in. (508 mm) Track Shoes	174 lb. (79 kg)	183 lb. (83 kg)	- 980 lb. (- 445 kg)
24-in. (610 mm) Track Shoes (adjust to base weight)			- 380 lb. (- 172 kg)
Cab	675 lb. (306 kg)	675 lb. (306 kg)	675 lb. (306 kg)
Counterweight			
Rear (each)	in base	330 lb. (150 kg)	330 lb. (150 kg)
Front (each)	in base	240 lb. (209 kg)	240 lb. (209 kg)
Front Tow Hook	in base	in base	in base
Retrieval Hitch	50 lb. (23 kg)	50 lb. (23 kg)	50 lb. (23 kg)
Extended Drawbar	72 lb. (33 kg)	72 lb. (33 kg)	72 lb. (33 kg)
Limb Risers	229 lb. (104 kg)	229 lb. (104 kg)	229 lb. (104 kg)
Screens			
Rear	76 lb. (34 kg)	76 lb. (34 kg)	76 lb. (34 kg)
Side	94 lb. (43 kg)	94 lb. (43 kg)	94 lb. (43 kg)
Front and Doors	179 lb. (81 kg)	179 lb. (81 kg)	179 lb. (81 kg)
Winch			
4000S	1,437 lb. (652 kg)	1,437 lb. (652 kg)	1,437 lb. (652 kg)
Fairlead, Four Roller	187 lb. (85 kg)	187 lb. (85 kg)	187 lb. (85 kg)
Ripper, Parallelogram	1,306 lb. (592 kg)	1,306 lb. (592 kg)	1,306 lb. (592 kg)
All-Hydraulic Heavy-Duty C Frame (less blade)	- 1,384 lb. (- 628 kg)	- 1,384 lb. (- 628 kg)	- 1,470 lb. (- 667 kg)
115-in. (2921 mm) Blade, All-Hydraulic Heavy-Duty C Frame (adjust to base weight)			- 134 lb. (- 61 kg)
121-in. (3073 mm) Blade, All-Hydraulic Heavy-Duty C Frame (adjust to base weight)			- 74 lb. (- 33 kg)

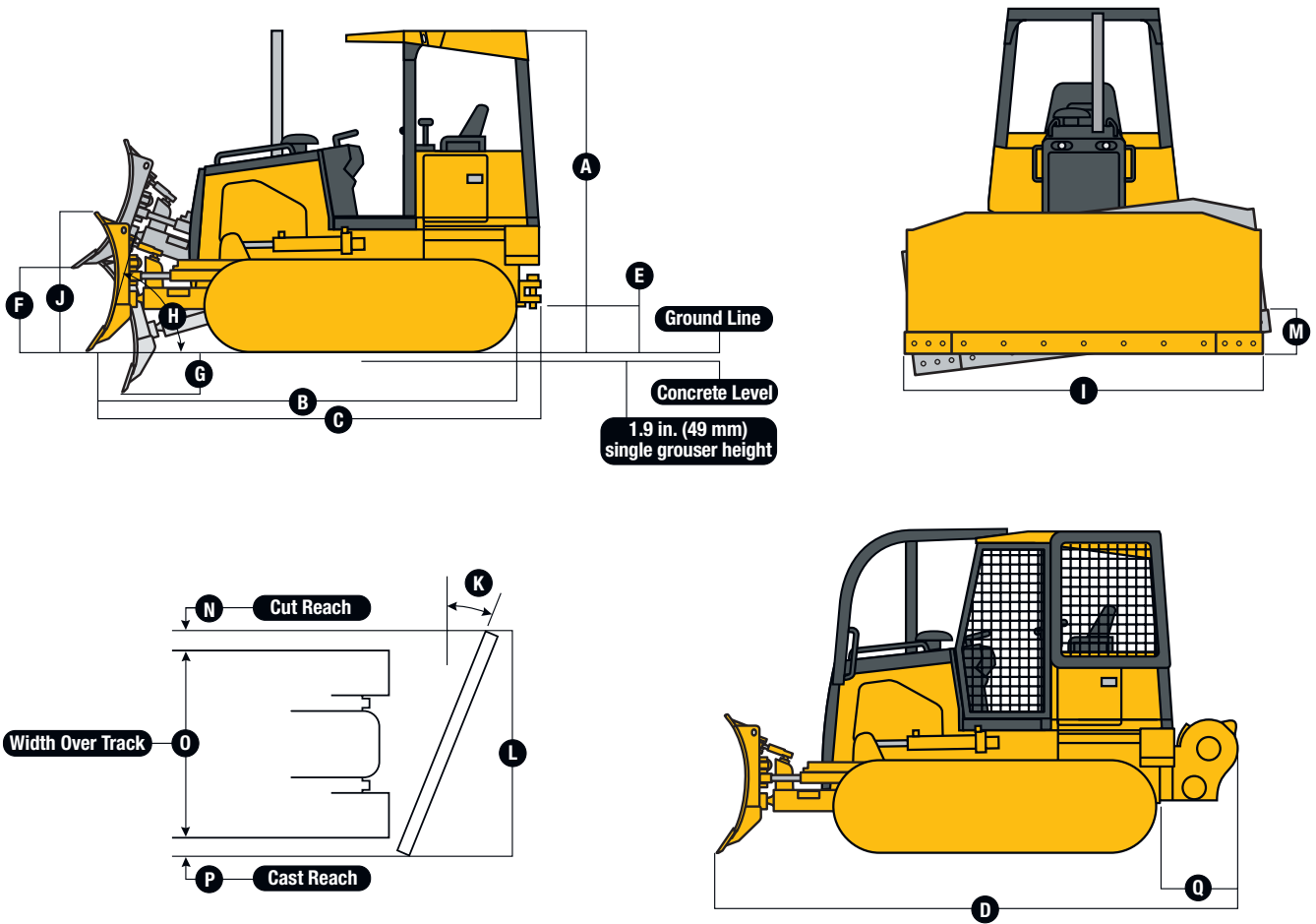

Machine Dimensions

	650J LT	650J XLT	650J LGP
A Overall Height (ROPS or cab)	9 ft. 1 in. (2769 mm)	9 ft. 1 in. (2769 mm)	9 ft. 1 in. (2769 mm)
Height of Grousers	1.9 in. (48 mm)	1.9 in. (48 mm)	1.9 in. (48.3 mm)
B Overall Length	13 ft. 5 in. (4089 mm)	13 ft. 11 in. (4242 mm)	13 ft. 11 in. (4242 mm)
C Overall Length with Extended Drawbar	13 ft. 10 in. (4216 mm)	14 ft. 1 in. (4293 mm)	14 ft. 1 in. (4293 mm)
D Overall Length with Winch	14 ft. 11 in. (4547 mm)	15 ft. 6 in. (4724 mm)	14 ft. 11 in. (4547 mm)
E Minimum Ground Clearance	14 in. (363 mm)	14.3 in. (363 mm)	14.3 in. (363 mm)
F Blade Lift Height	32 in. (818 mm)	32.2 in. (818 mm)	32.2 in. (818 mm)
G Blade Digging Depth	20 in. (500 mm)	19.7 in. (500 mm)	19.7 in. (500 mm)
H Blade Cutting Edge Angle, Adjustable	52 to 60 deg.	52 to 60 deg.	52 to 60 deg.

Forestry Application

Available limb risers and screens for the rollover protective structure, John Deere-built, self-contained 4000S Winch* for versatile skidding and clearing operations

D Overall Length with Winch**	14 ft. 11 in. (4547 mm)	15 ft. 6 in. (4737 mm)	14 ft. 11 in. (4547 mm)
Q 4000S Winch Length	30 in. (752 mm)	30 in. (752 mm)	30 in. (752 mm)

*Reference 4000S Winch spec sheet.
 **See above for related dimensions.

Blade Specs	650J LT	650J XLT	650J LGP
I Width	105 in. (2667 mm)	105 in. (2667 mm)	115 in. (2921 mm)
J Height	3 ft. 6 in. (1067 mm)	3 ft. 6 in. (1067 mm)	3 ft. 2 in. (955 mm)
SAE Capacity	2.91 cu. yd. (2.22 m ³)	2.9 cu. yd. (2.22 m ³)	2.57 cu. yd. (1.96 m ³)
K Blade Angle	22.2 deg.	22.2 deg.	22.2 deg.
L Angled Width	8 ft. 1 in. (2469 mm)	8 ft. 1 in. (2469 mm)	8 ft. 11 in. (2705 mm)
M Tilt	14.3 in. (363 mm)	14.3 in. (363 mm)	15.7 in. (399 mm)
N Cut Reach	4.6 in. (117 mm)	4.6 in. (117 mm)	0.2 in. (5 mm)
O Width Over Track	6 ft. 7 in. (2007 mm)	6 ft. 7 in. (2007 mm)	8 ft. 1 in. (2464 mm)
P Cast Reach	13.6 in. (345 mm)	13.6 in. (345 mm)	9.3 in. (236 mm)
I Width	115 in. (2921 mm)	115 in. (2921 mm)	124 in. (3150 mm)
J Height	3 ft. 2 in. (955 mm)	3 ft. 2 in. (955 mm)	2 ft. 11 in. (894 mm)
SAE Capacity	2.57 cu. yd. (1.96 m ³)	2.57 cu. yd. (1.96 m ³)	2.46 cu. yd. (1.88 m ³)
K Blade Angle	22.2 deg.	22.2 deg.	22.2 deg.
L Angled Width	8 ft. 11 in. (2705 mm)	8 ft. 11 in. (2705 mm)	9 ft. 7 in. (2916 mm)
M Tilt	15.7 in. (399 mm)	15.7 in. (399 mm)	16.9 in. (429 mm)
N Cut Reach	9.2 in. (233.68 mm)	9.2 in. (234 mm)	4.4 in. (112 mm)
O Width Over Track	6 ft. 7 in. (2007 mm)	6 ft. 7 in. (2007 mm)	8 ft. 1 in. (2464 mm)
P Cast Reach	18.3 in. (465 mm)	18.3 in. (465 mm)	13.4 in. (340 mm)
I Width	124 in. (3150 mm)	124 in. (3150 mm)	128 in. (3251 mm)
J Height	2 ft. 11 in. (894 mm)	2 ft. 11 in. (894 mm)	3 ft. 2 in. (955 mm)
SAE Capacity	2.46 cu. yd. (1.88 m ³)	2.46 cu. yd. (2.0 m ³)	2.91 cu. yd. (2.22 m ³)
K Blade Angle	22.2 deg.	22.2 deg.	22.2 deg.
L Angled Width	9 ft. 7 in. (2916 mm)	9 ft. 7 in. (2916 mm)	9 ft. 11 in. (3010 mm)
M Tilt	16.9 in. (429 mm)	16.9 in. (429 mm)	17.5 in. (445 mm)
N Cut Reach	13.4 in. (340.36 mm)	13.4 in. (340 mm)	6.2 in. (157 mm)
O Width Over Track	6 ft. 7 in. (2007 mm)	6 ft. 7 in. (2007 mm)	8 ft. 1 in. (2464 mm)
P Cast Reach	22.4 in. (569 mm)	22.4 in. (569 mm)	15.3 in. (389 mm)

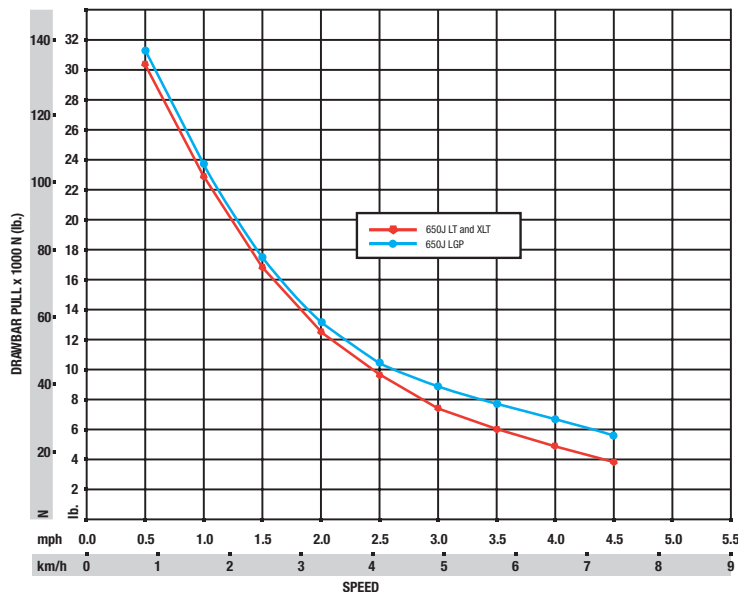

450J / 550J / 650J CRAWLER DOZERS

Key: ● Standard equipment ▲ Optional or special equipment

See your John Deere dealer for further information.

450 550 650 Engine

- ● ● Certified to EPA Tier 2 emissions
- ● ● Electronic control with automatic engine protection
- ● ● Dual safety element dry-type air cleaner, evacuator valve
- ● ● Muffler, self draining, under hood, with vertical stack
- ▲ ▲ ▲ Environmental service drains
- ▲ ▲ ▲ Ether start aid
- ▲ ▲ ▲ Engine coolant heater, 110 volts
- ▲ ▲ ▲ Engine coolant heater, fuel fired
- ▲ ▲ ▲ Chrome exhaust
- ▲ ▲ ▲ Fuel filter heater

Cooling

- ● ● Cooling fan, blower type
- ● ● Engine coolant radiator (10 fins per in.)
- ● ● Hydrostatic cooler (oil/air – 10 fins per in.)
- ● ● Turbo intercooler (air/air – 7 fins per in.)
- ● ● Enclosed safety fan guard (conforms to SAE J1308 and ISO3457)
- ● ● Perforated engine side shields
- ● ● Heavy-duty grille
- ▲ ▲ ▲ Extreme-duty grille
- ▲ ▲ ▲ Radiator sand screens

Transmission

- ● ● Remote diagnostic test ports
- ▲ ▲ ▲ Environmental service drains

Hydraulic System

- ● ● Three-function hydraulics
- ▲ ▲ ▲ Four-function hydraulics with rear plumbing
- ▲ ▲ ▲ Drive-through hydraulic pump for use with winch
- ▲ Integrated Grade Control (IGC)

Mainframe, Access Panels

- ● ● Front tow loop (bolt-on)
- ● ● Reinforced engine and mid-frame bottom guards
- ● ● Integral transmission guard
- ● ● Vandal protection: Engine access door / Side tank access doors / Fuel tank / Instrument panel / Transmission reservoir / Hydraulic reservoir

Attachments

- ▲ ▲ ▲ Retrieval hitch with pin
- ▲ ▲ ▲ Extended rigid drawbar with pin for pull-type implements
- ▲ ▲ ▲ Drawbar, extended for winch (with or without Fairlead)
- ▲ ▲ ▲ Ripper, parallelogram with five shank pockets and three teeth

450 550 650 Attachments (continued)

- ▲ ▲ ▲ Winch, John Deere, power in/free spool out OR power out
- ▲ ▲ ▲ Four-roller fairlead for winch
- ▲ ▲ ▲ Root-rake blade attachment
- ▲ ▲ ▲ Rear-mounted toolbox

Undercarriage

- ● ● Full-length, smooth-surface track frame covers
- ● ● Chain guides, front and rear
- ● ● Single-flange roller
- ▲ ▲ ● Double-flange rollers
- ▲ ▲ ▲ Extended life undercarriage with SC-2™ bushings
- ▲ ▲ ▲ Full-length rock guards
- ▲ Center track chain guide

Canopy Cab Operator's Station / Electrical

- ● Retractable seat belts, 2 in. (51 mm) (conform to SAE J386)
- ▲ ▲ Retractable seat belts, 3 in. (76 mm) (conform to SAE J386)
- ▲ Accessories: Convex wide-angle interior rearview mirror / Thigh cushions (2) / Seat-side lockable storage box/lunch box/cup holder
- ● Power port, 12 volts
- ▲ ▲ Lockable side-seat storage compartment
- ● Air conditioner, 24,000 Btu
- ● Tinted glass
- ● Dome light
- ● Heater (roof mount)
- ● Front and door wipers
- Mechanical suspension vinyl seat
- Mechanical suspension fabric seat
- ▲ Air suspension vinyl seat
- ▲ Air suspension fabric seat
- ▲ Under-seat heater
- ▲ Rear wiper
- ▲ AM/FM, weather-band radio, clock
- ▲ External-mounted attachment mirror
- ● Sealed alternator, 65 amps
- ● Master electrical disconnect switch
- ● Lights, grille mounted (2), rear mounted (1)
- ▲ Work lights, roof mounted
- ● Battery, single, 12 volts
- ▲ ▲ Battery, dual, 12 volts
- ▲ ▲ JDLink™

CONTROL OWNING AND OPERATING COSTS

Customer Personal Service (CPS) is part of John Deere's proactive, fix-before-fail strategy on machine maintenance that will help control costs, increase profits, and reduce stress. Included in this comprehensive lineup of ongoing programs and services are:

Fluid analysis program – tells you what's going on inside *all* of your machine's major components so you'll know if there's a problem *before* you see a decline in performance. Fluid analysis is included in most extended coverage and preventive-maintenance agreements.

Component life-cycle data – gives you vital information on the projected life span of components and lets you make informed decisions on machine maintenance by telling you approximately how many hours of use you can expect from an engine, transmission, or hydraulic pump. This information can be used to preempt catastrophic downtime by servicing major components at about 80 percent of their life cycle.

Preventive Maintenance (PM) agreements – give you a fixed cost for maintaining a machine for a given period of time. They also help you avoid downtime by

ensuring that critical maintenance work gets done right and on schedule. On-site preventive maintenance service performed where and when you need it helps protect you from the expense of catastrophic failures and lets you avoid waste-disposal hassles.

Extended coverage – gives you a fixed cost for machine repairs for a given period of time so you can effectively manage costs. Whether you work in a severe-service setting or just want to spread the risk of doing business, this is a great way to custom-fit coverage for your operation. And an extended coverage contract also travels well because it's backed by John Deere and is honored by *all* Deere construction dealers.

Customer Support Advisors (CSAs) – Deere believes the CSA program lends a *personal* quality to Customer Personal Service (CPS). Certified CSAs have the knowledge and skills for helping make important decisions on machine maintenance and repair. Their mission is to help you implement a plan that's right for *your* business and take the burden of machine maintenance off your shoulders.



JOHN DEERE

DKAJUDZR Litho in U.S.A. (07-04)

Net engine power is with standard equipment including air cleaner, exhaust system, alternator, and cooling fan at test conditions specified per ISO9249.

Specifications and design subject to change without notice. Wherever applicable, specifications are in accordance with SAE standards. Except where otherwise noted, these specifications are based on units with standard equipment, rollover protective structures, full fuel tanks, and 175-lb. (79 kg) operators.



Courtesy of Machine.Market