

524K-II/544K-II/ 624K-II LOADERS

97–139 kW (130–186 net hp)



JOHN DEERE





Powerful. And proven.

Got a material-handling app that demands extra agility and ability? There's a John Deere K Series-II Loader for that. Built on the highly reliable platform of their predecessors, these models are loaded with even more customer-inspired productivity- and uptime-increasing features. John Deere PowerTech™ EPA Final Tier 4 (FT4)/EU Stage IV diesels provide generous displacement, power, and lugging ability. Daily checks and maintenance access are even easier. And all new K Series-II Loaders come with a standard five-speed transmission, a new adaptive clutch cutoff, and new axles with brake retractors that will improve productivity while providing up to 10-percent fuel savings compared to previous K-Series models. Get more in a K Series-II.



| K-Series Specifications | 524K-II | 544K-II | 624K-II |
|---|--|--|---|
| Net Peak Power | 97 kW (130 hp) | 121 kW (163 hp) | 139 kW (186 hp) |
| Bucket Capacity | 1.9–3.4 m ³ (2.5–4.5 cu. yd.) | 2.1–4.0 m ³ (2.75–5.25 cu. yd.) | 2.7–4.0 m ³ (3.5–5.25 cu. yd.) |
| Z-Bar: Tipping Load (40-deg. full turn, no tire deflection, with pin-on bucket) | 9168 kg (20,212 lb.) | 9637 kg (21,246 lb.) | 12 006 kg (26,469 lb.) |
| Breakout Force | 9060 kg (19,974 lb.) | 10 115 kg (22,300 lb.) | 12 821 kg (28,266 lb.) |
| Operating Weight | 12 668 kg (27,928 lb.) | 13 217 kg (29,138 lb.) | 15 747 kg (34,717 lb.) |
| Powerllel™: Tipping Load (40-deg. full turn, no tire deflection, with coupler) | N/A | 7788 kg (17,170 lb.) | 9312 kg (20,530 lb.) |
| Breakout Force | N/A | 8604 kg (18,968 lb.) | 10 759 kg (23,719 lb.) |
| Operating Weight | N/A | 14 327 kg (31,586 lb.) | 17 167 kg (37,847 lb.) |
| Tool Carrier: Tipping Load (40-deg. full turn, no tire deflection, with coupler) | N/A | N/A | 10 253 kg (22,605 lb.) |
| Breakout Force | N/A | N/A | 10 978 kg (24,202 lb.) |
| Operating Weight | N/A | N/A | 16 166 kg (35,640 lb.) |

Easy rider.

Long days seem shorter when you're getting things done. And what operator wouldn't be more productive in the high-back air-ride seat of a K Series-II Loader? Up-front, an enhanced multifunction monitor displays operating, diagnostic, and maintenance info on a color LCD screen with easy-on-the-eyes clarity. Generous tinted glass and a low-profile console allow a commanding view of the work ahead. Spacious and quiet cab boasts plenty of legroom and fatigue-beating ergonomics, including convenience features such as seat-mounted loader controls. And sealed-switch module (SSM) with keyless start and effortless push-button operation of numerous machine functions. So you can work harder with less effort.

Adjustable automotive-style louvers provide effective airflow to keep the glass clear and the pressurized cab comfortable.

Available premium heated air-ride armchair seat adjusts multiple ways for extra comfort and cushioning.

To help prevent unauthorized machine operation, the keyless-start security system requires a numeric pass code (when activated).



Multi-language color LCD monitor provides push-button access to a wealth of machine data and functions:

- A. Vital and general operating info**, including transmission mode, gear, engine rpm, ground speed, fuel and diesel exhaust fluid (DEF) levels, and fluid temps.
- B. Enhanced onboard diagnostics** with speed, pressure, and temperature readings and real-time switch status.
- C. Customized machine settings** such as Quick Shift, Auto-to-1st, and optional Ride Control let you match operating characteristics to specific jobs and conditions.
- D. Optional embedded payload scale** weighs each bucket load, helping fill trucks to the max.





1. Cooler compartment and beverage holder make it handy to stow your lunch.

2. Optional rearview camera and radar object-detection system or rearview camera only displays the activity behind the machine on the LCD screen. Emits an audible alert for extra awareness in tight quarters and high-traffic areas.

3. Backlit touchpad in the SSM controls keyless start and 24 other machine functions, allowing the operator to activate boom-height kick-out, return-to-carry, and return-to-dig from the seat.



Control your productivity.

If you want maximum productivity, a K Series-II Loader should be on your jobsite. It's not just their big torque reserves that make them such impressive performers. Single-lever joystick or two-lever fingertip controls provide smooth effortless control. Excavator-style hydraulics sense the load and deliver the flow needed for smooth combined functions and fast work cycles. PowerShift™ torque-converter transmission on the 524K-II employs smart shift technology to continuously evaluate speed and load conditions, and adjusts clutch-pack engagement to suit. 544K-II and 624K-II feature standard five-speed transmission with lockup torque converter in gears 2–5, to increase acceleration, speed cycles, and optimize power and fuel efficiency during transport, roading, and ramp climbing. You won't find a smoother-shifting loader.

Boom-height kick-out and return-to-carry functions help speed production in repetitive loading applications. On 544K-II and 624K-II Powerllec-equipped models, the touchpad has two presets for added convenience when frequent attachment change-over is required.

Engine/hydraulic match maintains good boom and bucket power into and out of the pile. For big loads, even in wet or packed materials.

Responsive steering and full 80-deg. articulation increase maneuverability in tight quarters, for faster cycle times and fewer three-point turns.

Optional wheel-spin control boosts productivity by improving traction in troublesome material or underfoot conditions. Reduces tire wear, fuel costs, and operator fatigue, too.



Courtesy of Machine.Market



1. Choose single-lever joystick or two-lever fingertip pilot-operated hydraulic controls. Joystick F-N-R selector provides convenient direction and full-range gear changes. Both include innovative Quick-Shift feature for push-button gear changes, one gear at a time.
2. Hinged panel tilts away for quick ground-level access to both the fuel and diesel exhaust fluid (DEF) tanks, making refills convenient and easy.
3. New adaptive clutch cutoff automatically provides more power to the hydraulic system, ensures smooth control at high engine rpms and low speeds, and allows for better machine handling in all terrain without the operator having to change settings.



Get unparalleled Powerllec lift.

544K-II and 624K-II Powerllec Loaders deliver both powerful digging forces and parallel lift. Their innovative design allows load forces to work with, not against, the boom. For big breakout force, even in difficult digging. Impressive torque throughout the entire dump and rollback range enables Powerllec's to excel at a wide variety of material-handling tasks. But don't just look for these John Deere advantages in the numbers on a spec sheet. The best way to fully appreciate them is on your jobsite. Whatever the task, whatever the load, you'll discover parallel lift that's without parallel.



1. 544K-II and 624K-II Powerllel Loaders power outstanding breakout throughout the entire bucket and angle range to conquer tough tasks such as loading logs.

2. John Deere Worksite Pro™ couplers increase versatility and make attachment switchover push-button easy. Hi-Vis coupler picks up a broad range of Deere and other attachments so you can do more with one machine.



Bell crank is attached to the loader frame via a Y-shaped link, separating it from the cross tube. “Free-floating” bell-crank design allows load forces to work with, not against, the boom, for powerful breakout in tough digging.

Hi-Vis coupler fastens the attachment close to the machine for stability with heavy loads.

Tire and axle options let you equip your 544K-II or 624K-II Powerllel for material handling on a wide range of terrain.

Designed to hit deadlines — and new heights.

K Series-II Loaders come equipped with plenty of production-boosting features to help you handle almost anything you throw their way. But if yours isn't just any application, we've got you covered with a wide variety of factory- or dealer-installed options. So you can equip your loader with exactly what you need to maximize your efforts and expand your opportunities. Not all options are available on all loaders, so see your dealer for specific details.

1. With optional ride control, the lift cylinders act as shock absorbers, cushioning bumps to enable quick and easy navigation over rough ground without losing the load. Auto-actuation travel speed is adjustable from 1.5 to 24.0 km/h (1.0 to 15.0 mph) in increments of 0.5 units.
2. Embedded payload scale enables you to fill each truck to its legal limit, for maximum productivity. It's available on Z-Bar and High-Lift models.



Full-tire front and rear fenders and flaps help keep the machine free of mud and debris.

Heated mirrors prevent fog and ice from obstructing visibility and impacting productivity.

Courtesy of Machine.Market



General-purpose or excavating buckets are available in pin-on or coupler configurations from 1.9–2.7 m³ (2.5–3.5 cu. yd.). Or opt for forks with 1.22- and 1.52-m (48 and 60 in.) tines, depending on model.

Mine Safety and Health Administration (MSHA)-compliant self-cleaning steps and convenient handrails provide right-side access to the skid-resistant platform for cleaning windows.

Optional corrosion package shields electrical components and connections to help prevent corrosive materials from short-circuiting productivity.

Built to tackle whatever you've got.

It's all about uptime. So we gave the K Series-II plenty of resources to help you succeed. All three loaders come loaded with traditional John Deere durability features such as heavy-duty wet-sleeve diesels, Quad-Cool, and solid-state electrical systems. Reinforced articulation joints with double-tapered roller bearings. Plus, booms and mainframes so tough they're warranted for three years or 10,000 hours. When you know how they're built, you'll run a Deere.





Auto-idle applies the brakes and automatically reduces engine speed to help conserve fuel after an operator-determined period of inactivity. Auto shutdown turns off the engine after extended idleness.

Standard starter protection limits cranking time and requires cool-down periods between attempts.

Hydraulically driven fan runs only as needed for efficient cooling. Helps conserve precious fuel, too.

Electrical-distribution center employs highly reliable circuit-board technology and solid-state switches that eliminate numerous wiring harnesses, fuses, relays, and connectors. Sealed gold-pin electrical connectors resist corrosion, for superior long-term integrity.

1. Planetary final drives are mounted inboard. Hydraulic wet-disc brakes on all models self-adjust.

2. Optional programmable fan automatically reverses at predetermined intervals, ejecting debris from the radiator and cooler cores. Or set individual cleaning cycles through the monitor.

3. Quad-Cool places the radiator, air-conditioner condenser, intercooler, and hydraulic, transmission, and axle coolers (standard on the 624K-II, optional on the 524K-II and 544K-II) in a unique boxed configuration that's isolated from engine heat, boosting efficiency and durability.

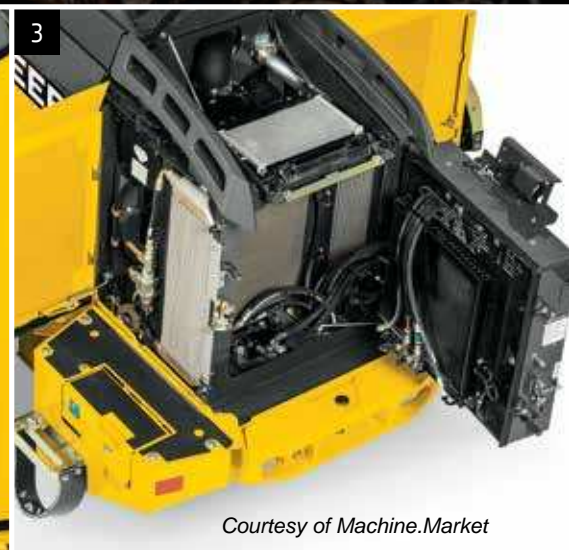

Save time — and your bottom line.

Controlling daily owning and operating costs shouldn't stretch your resources — and it doesn't on a K Series-II Loader. Same-side ground-level service points make quick work of the daily routine. Unique Quad-Cool system provides wide-open access to both sides of the coolers, easing cleanout. Extended service intervals let you work longer between changes. And because no maintenance beats low maintenance, standard self-adjusting serpentine engine belts and wet-disc brakes seldom, if ever, require attention. The list of maintenance-minimizing features — and the owning and operating savings — goes on and on.

1. Vertical spin-on filters allow quick, no-spill changes. 500-, 2,000-, and 4,000-hour engine, transmission, and hydraulic oil-change intervals help reduce operating costs.
2. Easy-to-navigate LCD monitor displays diagnostic messages if problems occur, and even offers possible solutions to help get you back up and running quickly.
3. Color-coded fluid-sample and diagnostic test ports help speed preventative maintenance and troubleshooting. Noninvasive design helps keep out contaminants.
4. Conveniently located, easy-to-read sight gauges and see-through reservoirs let you check transmission, hydraulic, coolant, and windshield washer fluid levels at a glance.
5. Lockable master electrical-disconnect switch, cab circuit breaker, and remote-start terminals are enclosed beneath the right-side step, for ground-level convenience.





3-mm (0.12 in.) side-shield perforations block most airborne debris. Unlike stacked coolers, Quad-Cool cores resist plugging and are easily accessible from either side, for quick and easy cleanout.

All daily service points including fuel are conveniently grouped on the left side of the machine.

Greasing is less messy, with centralized lube banks providing easy access to difficult-to-reach zerk. Periodic lube and maintenance chart conveniently ensures that nothing gets overlooked.

John Deere WorkSight™ is an exclusive suite of telematics solutions that increases uptime while lowering operating costs. At its heart, JDLink™ Ultimate machine monitoring provides real-time utilization data and alerts to help you maximize productivity and efficiency while minimizing downtime. Remote diagnostics enable your dealer to read codes, record performance data, and even update software without a trip to the jobsite.

Ultimate Uptime, featuring John Deere WorkSight, is a customizable support solution available exclusively from your Deere dealer. This flexible offering maximizes equipment availability with standard John Deere WorkSight capabilities that can help prevent future downtime and speed repairs when needed. In addition to the base John Deere WorkSight features, our dealers work with you to build an uptime package that meets the specific needs of your machine, fleet, project, and business, including customized maintenance and repair agreements, onsite parts availability, extended warranties, fluid sampling, response-time guarantees, and more.



524K-II

| | | |
|---|--|-------------------------|
| Engine | 524K-II Z-BAR / HIGH-LIFT | |
| Manufacturer and Model | John Deere PowerTech™ PVS 6068 | |
| Non-Road Emission Standard | EPA Final Tier 4/EU Stage IV | |
| Cylinders | 6 | |
| Valves Per Cylinder | 4 | |
| Displacement | 6.8 L (414 cu. in.) | |
| Net Peak Power (ISO 9249) | 97 kW (130 hp) at 1,700 rpm | |
| Net Peak Torque (ISO 9249) | 640 Nm (472 lb.-ft.) at 1,100 rpm | |
| Net Torque Rise | 65% | |
| Fuel System (electronically controlled) | High-pressure common rail | |
| Lubrication | Full-flow spin-on filter and integral cooler | |
| Aspiration | Turbocharged, charge air cooled | |
| Air Cleaner | Under-hood, dual-element dry type, restriction indicator in cab monitor for service | |
| Cooling | | |
| Fan Drive | Hydraulically driven, proportionally controlled, fan aft of coolers | |
| Electrical | | |
| Electrical System | 24 volt with 100-amp (130-amp optional) alternator | |
| Batteries (2 – 12 volt) | 950 CCA (each) | |
| Transmission System | | |
| Type | Countershaft-type PowerShift™ | |
| Torque Converter | Single stage, single phase | |
| Shift Control | Electronically modulated, adaptive, load and speed dependent | |
| Operator Interface | Steering-column or joystick-mounted F-N-R and gear-select lever; Quick-Shift button on hydraulic lever | |
| Shift Modes | Manual/auto (1st–D or 2nd–D); Quick-Shift button with 2 selectable modes: kick-down or kick-up/down; and adaptive clutch cutoff | |
| Maximum Travel Speeds (with 20.5 R 25 tires) | <i>Forward</i> | <i>Reverse</i> |
| Range 1 | 5.5 km/h (3.4 mph) | 5.8 km/h (3.6 mph) |
| Range 2 | 11.7 km/h (7.3 mph) | 12.3 km/h (7.6 mph) |
| Range 3 | 17.9 km/h (11.1 mph) | 27.6 km/h (17.1 mph) |
| Range 4 | 25.8 km/h (16.0 mph) | N/A |
| Range 5 | 38.5 km/h (23.9 mph) | N/A |
| Axles/Brakes | | |
| Final Drives | Heavy-duty inboard-mounted planetary | |
| Differentials | Hydraulic locking front with conventional rear – standard; dual locking front and rear – optional | |
| Rear Axle Oscillation, Stop to Stop (with 20.5 R 25 tires) | 24 deg. (12 deg. each direction) | |
| Service Brakes (conform to ISO 3450) | Hydraulically actuated, spring-retracted, self-adjusting inboard sun-shaft mounted, oil cooled, single disc | |
| Parking Brakes (conform to ISO 3450) | Automatic spring applied, hydraulically released, driveline mounted, sealed wet multi disc | |
| Tires/Wheels (see page 20 for complete tire adjustments) | | |
| | <i>Tread Width</i> | <i>Width Over Tires</i> |
| Michelin 20.5 R 25, 1 Star L-3 | 1950 mm (76.8 in.) | 2546 mm (100.2 in.) |
| Serviceability | | |
| Refill Capacities | | |
| Fuel Tank (with lockable cap) | 220 L (58 gal.) | |
| Cooling System | 23.5 L (24.8 qt.) | |
| Diesel Exhaust Fluid (DEF) | 19 L (20 qt.) | |
| Engine Oil with Vertical Spin-On Filter | 19.5 L (20.6 qt.) | |
| Transmission Reservoir with Vertical Filter | 21.5 L (22.7 qt.) | |
| Axle Oil (front and rear, each) | 18 L (19 qt.) | |
| Hydraulic Reservoir and Filter | 118.7 L (31.35 gal.) | |
| Park Brake Oil (wet disc) | 0.3 L (10 oz.) | |
| Hydraulic System/Steering | | |
| Pump (loader and steering) | Variable-displacement, axial-piston pump; closed-center, pressure-compensating system | |
| Maximum Rated Flow at 6895 kPa (1,000 psi) and 2,350 rpm | 165 L/m (44 gpm) | |
| System Relief Pressure (loader and steering) | 24 994 kPa (3,625 psi) | |
| Loader Controls | 2-function valve; joystick control or fingertip controls; hydraulic-function enable/disable; optional 3rd- and 4th-function valve with auxiliary lever | |
| Steering (conforms to ISO 5010) | Steering-column-mounted, twist-grip shift lever; Quick-Shift button on hydraulic lever | |
| Type | Power, fully hydraulic | |
| Articulation Angle | 80-deg. arc (40 deg. each direction) | |
| Turning Radius (measured to centerline of outside tire) | 5.0 m (16 ft. 5 in.) | |

524K-II



Hydraulic System/Steering *(continued)*

524K-II Z-BAR / HIGH-LIFT

Hydraulic Cycle Times

| | |
|--------------------|-----------|
| Raise | 5.7 sec. |
| Dump | 1.3 sec. |
| Lower (float down) | 3.0 sec. |
| Total | 10.0 sec. |

Dimensions and Specifications with Pin-On Bucket

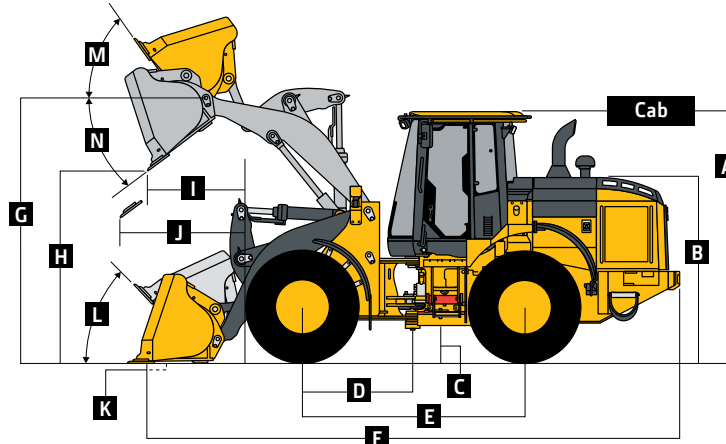

524K-II Z-BAR AND HIGH-LIFT LOADERS WITH PIN-ON BUCKET

| | Z-Bar | High-Lift |
|---|---|---|
| Dimensions with Bucket | 2.1-m ³ (2.75 cu. yd.) general-purpose with bolt-on edge | 2.1-m ³ (2.75 cu. yd.) general-purpose with bolt-on edge |
| A Height to Top of Cab | 3.25 m (10 ft. 8 in.) | 3.25 m (10 ft. 8 in.) |
| B Hood Height | 2.375 m (7 ft. 9 in.) | 2.375 m (7 ft. 9 in.) |
| C Ground Clearance | 0.40 m (15.7 in.) | 0.40 m (15.7 in.) |
| D Length from Centerline to Front Axle | 1.45 m (4 ft. 9 in.) | 1.45 m (4 ft. 9 in.) |
| E Wheelbase | 2.93 m (9 ft. 7 in.) | 2.93 m (9 ft. 7 in.) |
| F Overall Length, Bucket on Ground | 7.34 m (24 ft. 1 in.) | 7.67 m (25 ft. 2 in.) |
| G Height to Hinge Pin, Fully Raised | 3.77 m (12 ft. 5 in.) | 4.12 m (13 ft. 6 in.) |
| H Dump Clearance, 45 deg., Full Height | 2.77 m (9 ft. 1 in.) | 3.12 m (10 ft. 3 in.) |
| I Reach, 45-deg. Dump, Full Height | 0.98 m (3 ft. 2 in.) | 0.99 m (3 ft. 3 in.) |
| J Reach, 45-deg. Dump, 2.13-m (7 ft. 0 in.) Clearance | 1.44 m (4 ft. 9 in.) | 1.73 m (5 ft. 8 in.) |
| K Maximum Digging Depth | 97 mm (3.8 in.) | 222 mm (8.7 in.) |
| L Maximum Rollback at Ground Level | 41 deg. | 41 deg. |
| M Maximum Rollback, Boom Fully Raised | 55 deg. | 50 deg. |
| N Maximum Bucket Dump Angle, Fully Raised | 51 deg. | 47 deg. |
| Loader Clearance Circle, Bucket Carry Position | 11.60 m (38 ft. 1 in.) | 11.90 m (39 ft. 1 in.) |
| Specifications with Bucket | | |
| Capacity, Heaped | 2.1 m ³ (2.75 cu. yd.) | 2.1 m ³ (2.75 cu. yd.) |
| Capacity, Struck | 1.7 m ³ (2.27 cu. yd.) | 1.7 m ³ (2.27 cu. yd.) |
| Bucket Weight with Bolt-On Cutting Edge | 1013 kg (2,233 lb.) | 1013 kg (2,233 lb.) |
| Bucket Width | 2.54 m (8 ft. 4 in.) | 2.54 m (8 ft. 4 in.) |
| Breakout Force | 9060 kg (19,974 lb.) | 8371 kg (18,455 lb.) |
| Tipping Load, Straight, No Tire Deflection | 10 540 kg (23,237 lb.) | 9071 kg (19,998 lb.) |
| Tipping Load, Straight, with Tire Deflection | 10 014 kg (22,077 lb.) | 8664 kg (19,101 lb.) |
| Tipping Load, 40-deg. Full Turn, No Tire Deflection | 9168 kg (20,212 lb.) | 7862 kg (17,333 lb.) |
| Tipping Load, 40-deg. Full Turn, with Tire Deflection | 8496 kg (18,730 lb.) | 7335 kg (16,171 lb.) |
| Rated Operating Load, 50% Full-Turn Tipping Load, No Tire Deflection (conforms to ISO 14397-1)* | 4584 kg (10,106 lb.) | 3931 kg (8,666 lb.) |
| Rated Operating Load, 50% Full-Turn Tipping Load, with Tire Deflection (conforms to ISO 14397-1)* | 4248 kg (9,365 lb.) | 3667 kg (8,084 lb.) |
| Operating Weight | 12 668 kg (27,928 lb.) | 12 877 kg (28,389 lb.) |

Loader operating information is based on machine with identified linkage and standard equipment, PowerTech PVS 6068 (EPA Final Tier 4/EU Stage IV) engine, ROPS cab, rear cast bumper/counterweight, transmission side-frame guards, bottom guards, standard tires, full fuel tank, and 79-kg (175 lb.) operator. This information is affected by changes in tires, ballast, and different attachments.

*Rated operating capacity based on Deere attachments only.

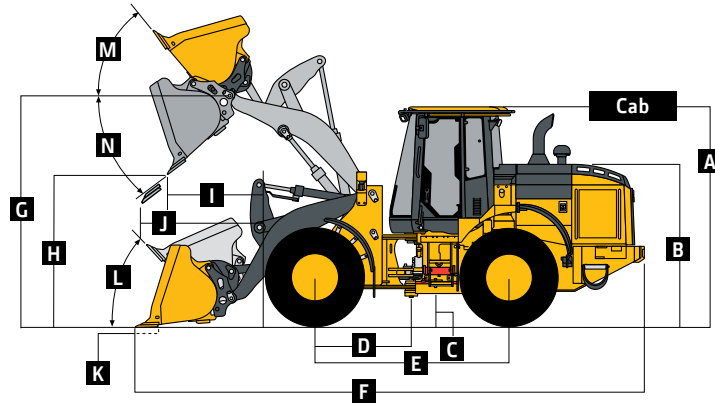

524K-II Z-BAR AND HIGH-LIFT LOADERS WITH QUICK-COUPLER AND HOOK-ON BUCKET

| | Z-Bar | Z-Bar | High-Lift | High-Lift |
|---|---|---|---|---|
| Dimensions with Bucket | <i>2.1-m³ (2.75 cu. yd.) general-purpose with bolt-on edge</i> | <i>3.1-m³ (4.0 cu. yd.) light-material with bolt-on edge</i> | <i>2.1-m³ (2.75 cu. yd.) general-purpose with bolt-on edge</i> | <i>3.1-m³ (4.0 cu. yd.) light-material with bolt-on edge</i> |
| A Height to Top of Cab | 3.25 m (10 ft. 8 in.) | 3.25 m (10 ft. 8 in.) | 3.25 m (10 ft. 8 in.) | 3.25 m (10 ft. 8 in.) |
| B Hood Height | 2.375 m (7 ft. 9 in.) | 2.375 m (7 ft. 9 in.) | 2.375 m (7 ft. 9 in.) | 2.375 m (7 ft. 9 in.) |
| C Ground Clearance | 0.40 m (15.7 in.) | 0.40 m (15.7 in.) | 0.40 m (15.7 in.) | 0.40 m (15.7 in.) |
| D Length from Centerline to Front Axle | 1.45 m (4 ft. 9 in.) | 1.45 m (4 ft. 9 in.) | 1.45 m (4 ft. 9 in.) | 1.45 m (4 ft. 9 in.) |
| E Wheelbase | 2.93 m (9 ft. 7 in.) | 2.93 m (9 ft. 7 in.) | 2.93 m (9 ft. 7 in.) | 2.93 m (9 ft. 7 in.) |
| F Overall Length, Bucket on Ground | 7.57 m (24 ft. 10 in.) | 7.73 m (24 ft. 6 in.) | 7.90 m (25 ft. 11 in.) | 8.05 m (25 ft. 7 in.) |
| G Height to Hinge Pin, Fully Raised | 3.77 m (12 ft. 5 in.) | 3.77 m (12 ft. 5 in.) | 4.12 m (13 ft. 6 in.) | 4.12 m (13 ft. 6 in.) |
| H Dump Clearance, 45 deg., Full Height | 2.61 m (8 ft. 7 in.) | 2.50 m (8 ft. 2 in.) | 2.96 m (9 ft. 8 in.) | 2.80 m (9 ft. 2 in.) |
| I Reach, 45-deg. Dump, Full Height | 1.10 m (3 ft. 7 in.) | 1.11 m (3 ft. 8 in.) | 1.11 m (3 ft. 8 in.) | 1.13 m (3 ft. 8 in.) |
| J Reach, 45-deg. Dump, 2.13-m (7 ft. 0 in.) Clearance | 1.47 m (4 ft. 10 in.) | 1.40 m (4 ft. 7 in.) | 1.77 m (5 ft. 10 in.) | 1.71 m (5 ft. 7 in.) |
| K Maximum Digging Depth | 146 mm (5.7 in.) | 225 mm (8.8 in.) | 226 mm (10.3 in.) | 307 mm (12.08 in.) |
| L Maximum Rollback at Ground Level | 40 deg. | 41 deg. | 45 deg. | 41 deg. |
| M Maximum Rollback, Boom Fully Raised | 54 deg. | 55 deg. | 48 deg. | 48 deg. |
| N Maximum Bucket Dump Angle, Fully Raised | 48 deg. | 51 deg. | 48 deg. | 47 deg. |
| Loader Clearance Circle, Bucket Carry Position | 11.77 m (38 ft. 7 in.) | 12.13 m (39 ft. 9 in.) | 12.08 m (39 ft. 8 in.) | 12.47 m (40 ft. 11 in.) |
| Specifications with Bucket | | | | |
| Capacity, Heaped | 2.1 m ³ (2.75 cu. yd.) | 3.1 m ³ (4.0 cu. yd.) | 2.1 m ³ (2.75 cu. yd.) | 3.1 m ³ (4.0 cu. yd.) |
| Capacity, Struck | 1.7 m ³ (2.27 cu. yd.) | 2.59 m ³ (3.4 cu. yd.) | 1.7 m ³ (2.27 cu. yd.) | 2.59 m ³ (3.4 cu. yd.) |
| Bucket Weight with Bolt-On Cutting Edge | 1421 kg (3,133 lb.) | 1693 kg (3,732 lb.) | 1421 kg (3,133 lb.) | 1693 kg (3,732 lb.) |
| Bucket Width | 2.54 m (8 ft. 4 in.) | 2.89 m (9 ft. 6 in.) | 2.54 m (8 ft. 4 in.) | 2.89 m (9 ft. 6 in.) |
| Breakout Force | 7446 kg (16,415 lb.) | 6708 kg (14,789 lb.) | 6861 kg (15,126 lb.) | 6219 kg (13,710 lb.) |
| Tipping Load, Straight, No Tire Deflection | 9281 kg (20,461 lb.) | 8838 kg (19,484 lb.) | 8000 kg (17,637 lb.) | 7582 kg (16,715 lb.) |
| Tipping Load, Straight, with Tire Deflection | 8823 kg (19,451 lb.) | 8382 kg (18,479 lb.) | 7635 kg (16,832 lb.) | 7221 kg (15,919 lb.) |
| Tipping Load, 40-deg. Full Turn, No Tire Deflection | 8020 kg (17,681 lb.) | 7597 kg (16,748 lb.) | 6880 kg (15,168 lb.) | 6480 kg (14,286 lb.) |
| Tipping Load, 40-deg. Full Turn, with Tire Deflection | 7434 kg (16,389 lb.) | 7014 kg (15,463 lb.) | 6408 kg (14,127 lb.) | 6006 kg (13,241 lb.) |
| Rated Operating Load, 50% Full-Turn Tipping Load, No Tire Deflection (conforms to ISO 14397-1)* | 4010 kg (8,840 lb.) | 3798 kg (8,373 lb.) | 3440 kg (7,583 lb.) | 3240 kg (7,143 lb.) |
| Rated Operating Load, 50% Full-Turn Tipping Load, with Tire Deflection (conforms to ISO 14397-1)* | 3717 kg (8,195 lb.) | 3507 kg (7,732 lb.) | 3204 kg (7,064 lb.) | 3003 kg (6,620 lb.) |
| Operating Weight | 13 077 kg (28,830 lb.) | 13 349 kg (29,429 lb.) | 13 286 kg (29,291 lb.) | 13 557 kg (29,888 lb.) |

Loader operating information is based on machine with identified linkage and standard equipment, PowerTech PVS 6068 (EPA Final Tier 4/EU Stage IV) engine, ROPS cab, rear cast bumper/counterweight, transmission side-frame guards, bottom guards, standard tires, full fuel tank, and 79-kg (175 lb.) operator. This information is affected by changes in tires, ballast, and different attachments.

*Rated operating capacity based on Deere attachments only.

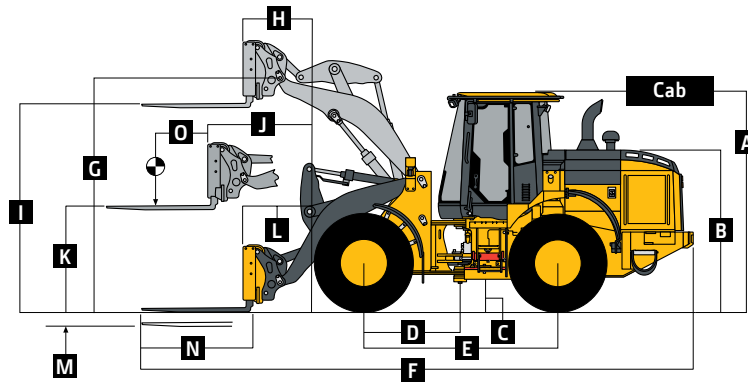

524K-II Z-BAR AND HIGH-LIFT LOADERS WITH QUICK-COUPLER AND HOOK-ON CONSTRUCTION FORKS

| | Z-Bar | Z-Bar | High-Lift | High-Lift |
|--|-----------------------------|-----------------------------|-----------------------------|-----------------------------|
| | 1.22-m (48 in.) tine length | 1.52-m (60 in.) tine length | 1.22-m (48 in.) tine length | 1.52-m (60 in.) tine length |
| Dimensions with Forks | | | | |
| A Height to Top of Cab | 3.25 m (10 ft. 8 in.) | 3.25 m (10 ft. 8 in.) | 3.25 m (10 ft. 8 in.) | 3.25 m (10 ft. 8 in.) |
| B Hood Height | 2.30 m (7 ft. 7 in.) | 2.30 m (7 ft. 7 in.) | 2.30 m (7 ft. 7 in.) | 2.30 m (7 ft. 7 in.) |
| C Ground Clearance | 0.40 m (15.7 in.) | 0.40 m (15.7 in.) | 0.40 m (15.7 in.) | 0.40 m (15.7 in.) |
| D Length from Centerline to Front Axle | 1.45 m (4 ft. 9 in.) | 1.45 m (4 ft. 9 in.) | 1.45 m (4 ft. 9 in.) | 1.45 m (4 ft. 9 in.) |
| E Wheelbase | 2.93 m (9 ft. 7 in.) | 2.93 m (9 ft. 7 in.) | 2.93 m (9 ft. 7 in.) | 2.93 m (9 ft. 7 in.) |
| F Overall Length, Forks on Ground | 7.88 m (25 ft. 10 in.) | 8.18 m (26 ft. 10 in.) | 8.21 m (26 ft. 11 in.) | 8.51 m (27 ft. 11 in.) |
| G Height to Hinge Pin, Fully Raised | 3.77 m (12 ft. 5 in.) | 3.77 m (12 ft. 5 in.) | 4.12 m (13 ft. 6 in.) | 4.12 m (13 ft. 6 in.) |
| H Reach, Fully Raised | 0.80 m (31.3 in.) | 0.80 m (31.3 in.) | 0.81 m (31.9 in.) | 0.81 m (31.9 in.) |
| I Fork Height, Fully Raised | 3.55 m (11 ft. 8 in.) | 3.55 m (11 ft. 8 in.) | 3.90 m (12 ft. 9 in.) | 3.90 m (12 ft. 9 in.) |
| J Maximum Reach, Fork Level | 1.54 m (5 ft. 1 in.) | 1.54 m (5 ft. 1 in.) | 1.80 m (5 ft. 11 in.) | 1.80 m (5 ft. 11 in.) |
| K Fork Height, Maximum Reach | 1.72 m (5 ft. 8 in.) | 1.72 m (5 ft. 8 in.) | 1.72 m (5 ft. 8 in.) | 1.72 m (5 ft. 8 in.) |
| L Reach, Ground Level | 0.94 m (3 ft. 1 in.) | 0.94 m (3 ft. 1 in.) | 1.27 m (4 ft. 2 in.) | 1.27 m (4 ft. 2 in.) |
| M Depth Below Ground | 16 mm (0.6 in.) | 16 mm (0.6 in.) | 95 mm (3.7 in.) | 95 mm (3.7 in.) |
| N Tine Length | 1.22 m (48 in.) | 1.52 m (60 in.) | 1.22 m (48 in.) | 1.52 m (60 in.) |
| O Load Position, 50% Tine Length | 0.61 m (24 in.) | 0.76 m (30 in.) | 0.61 m (24 in.) | 0.76 m (30 in.) |
| Specifications with Forks | | | | |
| Tipping Load, Straight, No Tire Deflection | 7256 kg (15,997 lb.) | 6849 kg (15,099 lb.) | 6574 kg (14,493 lb.) | 6227 kg (13,728 lb.) |
| Tipping Load, Straight, with Tire Deflection | 7068 kg (15,582 lb.) | 6681 kg (14,729 lb.) | 6414 kg (14,140 lb.) | 6081 kg (13,406 lb.) |
| Tipping Load, 40-deg. Full Turn, No Tire Deflection | 6303 kg (13,896 lb.) | 5943 kg (13,102 lb.) | 5690 kg (12,544 lb.) | 5383 kg (11,867 lb.) |
| Tipping Load, 40-deg. Full Turn, with Tire Deflection | 6054 kg (13,347 lb.) | 5718 kg (12,606 lb.) | 5472 kg (12,064 lb.) | 5175 kg (11,409 lb.) |
| Rated Operating Load, 50% Full-Turn Tipping Load, with Tire Deflection (conforms to ISO 14397-1 and SAE J1197)* | 3027 kg (6,673 lb.) | 2859 kg (6,303 lb.) | 2736 kg (6,032 lb.) | 2587 kg (5,703 lb.) |
| Rated Operating Load, Rough Terrain, 60% Full-Turn Tipping Load, with Tire Deflection (conforms to EN474-3)* | 3632 kg (8,007 lb.) | 3431 kg (7,564 lb.) | 3283 kg (7,238 lb.) | 3105 kg (6,845 lb.) |
| Rated Operating Load, Firm and Level Ground, 80% Full-Turn Tipping Load, with Tire Deflection (conforms to EN474-3)* | 4843 kg (10,677 lb.) | 4574 kg (10,084 lb.) | 4378 kg (9,652 lb.) | 4140 kg (9,127 lb.) |
| Operating Weight | 12 710 kg (28,021 lb.) | 12 753 kg (28,115 lb.) | 12 918 kg (28,479 lb.) | 12 961 kg (28,574 lb.) |
| <i>Loader operating information is based on machine with identified linkage and standard equipment, PowerTech PVS 6068 (EPA Final Tier 4/EU Stage IV) engine, ROPS cab, rear cast bumper/counterweight, transmission side-frame guards, bottom guards, standard tires, full fuel tank, and 79-kg (175 lb.) operator. This information is affected by changes in tires, ballast, and different attachments.</i> | | | | |
| <i>*Rated operating capacity based on Deere attachments only.</i> | | | | |

Adjustments to Operating Weights and Tipping Loads with Buckets

524K-II Z-BAR / HIGH-LIFT

Adjustments to operating weights, tipping loads, and tires are based on Z-Bar machine with pin-on 2.1-m³ (2.75 cu. yd.) general-purpose bucket with bolt-on cutting edge, ROPS cab, rear cast bumper/counterweight, transmission side-frame guards, bottom guards, standard tires, full fuel tank, and 79-kg (175 lb.) operator*

| Add (+) or deduct (-) kg (lb.) as indicated for loaders with 3-piece rims | Operating Weight | Tipping Load, Straight | Tipping Load, 40-deg. Full Turn | Tread Width | Width Over Tires | Vertical Height |
|---|-------------------------|--------------------------|---------------------------------|--------------------|-------------------|--------------------|
| John Deere PowerTech PVS 6068 | 0 kg (0 lb.) | 0 kg (0 lb.) | 0 kg (0 lb.) | N/A | N/A | N/A |
| John Deere PowerTech E 6068H | | | | | | |
| Z-Bar | -1 kg (-2.2 lb.) | +147 kg (+324 lb.) | +113 kg (+249 lb.) | N/A | N/A | N/A |
| High-Lift | -41 kg (-90 lb.) | +40 kg (+88 lb.) | +25 kg (+55 lb.) | N/A | N/A | N/A |
| Michelin 20.5 R 25, 1 Star L-3 | 0 kg (0 lb.) | 0 kg (0 lb.) | 0 kg (0 lb.) | 0 mm (0 in.) | 0 mm (0 in.) | 0 mm (0 in.) |
| Bridgestone 20.5 R 25, 1 Star L-3 | +44 kg (+97 lb.) | +32 kg (+70 lb.) | +28 kg (+62 lb.) | 0 mm (0 in.) | -5 mm (-0.2 in.) | -5 mm (-0.2 in.) |
| Titan 20.5 R 25, 1 Star L-3 | -4 kg (-9 lb.) | -3 kg (-6 lb.) | -2 kg (-5 lb.) | 0 mm (0 in.) | -5 mm (-0.2 in.) | -5 mm (-0.2 in.) |
| Michelin 20.5 R 25, 1 Star L-2 | -172 kg (-379 lb.) | -125 kg (-275 lb.) | -110 kg (-242 lb.) | 0 mm (0 in.) | -5 mm (-0.2 in.) | -5 mm (-0.2 in.) |
| Bridgestone 20.5 R 25, 1 Star L-2 | -80 kg (-176 lb.) | -58 kg (-128 lb.) | -51 kg (-112 lb.) | 0 mm (0 in.) | -5 mm (-0.2 in.) | -5 mm (-0.2 in.) |
| Titan 20.5 R 25, 1 Star L-2 | -100 kg (-220 lb.) | -73 kg (-161 lb.) | -64 kg (-141 lb.) | 0 mm (0 in.) | -5 mm (-0.2 in.) | -5 mm (-0.2 in.) |
| Titan 20.5-25, 16 PR L-2 | -260 kg (-573 lb.) | -190 kg (-419 lb.) | -167 kg (-368 lb.) | 0 mm (0 in.) | -2 mm (-0.1 in.) | +3 mm (+0.1 in.) |
| Firestone 20.5-25, 16 PR L-2 | -280 kg (-617 lb.) | -204 kg (-450 lb.) | -180 kg (-397 lb.) | 0 mm (0 in.) | -2 mm (-0.1 in.) | +3 mm (+0.1 in.) |
| Firestone 20.5-25, 12 PR L-2 | -316 kg (-697 lb.) | -231 kg (-509 lb.) | -203 kg (-448 lb.) | 0 mm (0 in.) | -2 mm (-0.1 in.) | +3 mm (+0.1 in.) |
| Titan 20.5-25, 12 PR L-2 | -280 kg (-617 lb.) | -204 kg (-450 lb.) | -180 kg (-397 lb.) | 0 mm (0 in.) | -2 mm (-0.1 in.) | +3 mm (+0.1 in.) |
| Firestone 20.5-25, 16 PR L-3 | -252 kg (-556 lb.) | -184 kg (-405 lb.) | -162 kg (-357 lb.) | 0 mm (0 in.) | -2 mm (-0.1 in.) | +9 mm (+0.4 in.) |
| Michelin 20.5 R 25 L2 Sno-Plus | -100 kg (-220 lb.) | -73 kg (-161 lb.) | -64 kg (-141 lb.) | 0 mm (0 in.) | +7 mm (+0.28 in.) | -16 mm (-0.6 in.) |
| 620/75R26 MegaXbib ^{6B} | -200 kg (-441 lb.) | -146 kg (-322 lb.) | -129 kg (-284 lb.) | +189 mm (+7.4 in.) | +61 mm (+2.4 in.) | +22 mm (+0.86 in.) |
| CaCl ₂ in 20.5-25, L-3 Rear Tires, 75% Fill | +825 kg (+1,820 lb.) | +1010 kg (+2,227 lb.) | +891 kg (+1,964 lb.) | N/A | N/A | N/A |

*May change based on vehicle configuration, weight, or tire-pressure adjustments.

⁵Equipped with 1-piece rims.

^{6B}Requires 8-deg. rear axle stops.

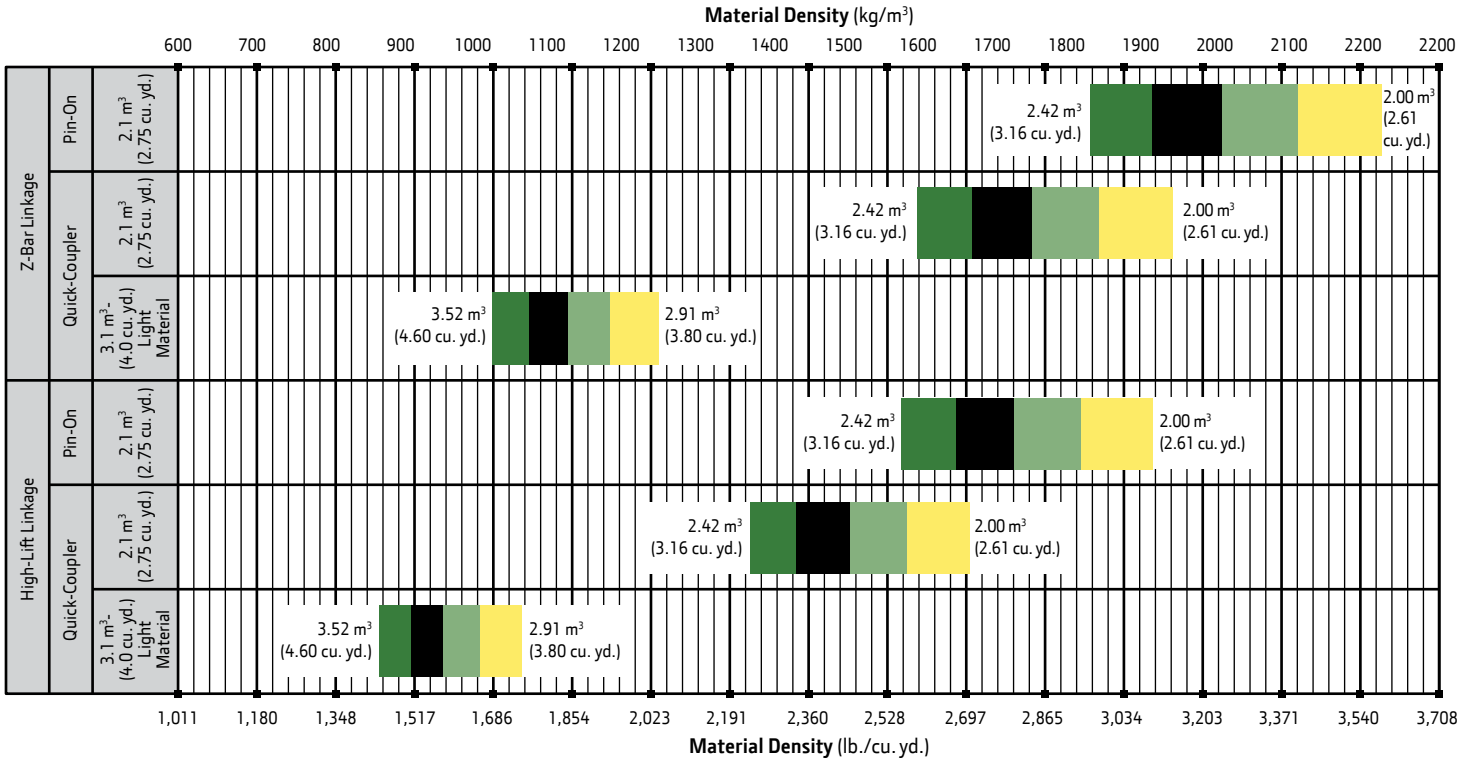

| LOOSE MATERIALS | | kg/m³ | lb./cu. yd. | LOOSE MATERIALS | | kg/m³ | lb./cu. yd. |
|----------------------------------|------|-------|---|-----------------|-------|-------|-------------|
| Chips, pulpwood | 288 | 486 | Limestone, coarse, sized | 1570 | 2,646 | | |
| Cinders (coal, ashes, clinkers) | 673 | 1,134 | Limestone, mixed sizes | 1682 | 2,835 | | |
| Clay and gravel, dry | 1602 | 2,700 | Limestone, pulverized or crushed | 1362 | 2,295 | | |
| Clay, compact, solid | 1746 | 2,943 | Sand, damp | 2083 | 3,510 | | |
| Clay, dry in lump loose | 1009 | 1,701 | Sand, dry | 1762 | 2,970 | | |
| Clay, excavated in water | 1282 | 2,160 | Sand, voids, full of water | 2083 | 3,510 | | |
| Coal, anthracite, broken, loose | 865 | 1,458 | Sandstone, quarried | 1314 | 2,214 | | |
| Coal, bituminous, moderately wet | 801 | 1,350 | Shale, broken crushed | 1362 | 2,295 | | |
| Earth, common loam, dry | 1218 | 2,052 | Slag, furnace granulated | 1955 | 3,294 | | |
| Earth, mud, packed | 1843 | 3,105 | Stone or gravel, 37.5 to 87.5-mm (1.5 to 3.5") size | 1442 | 2,430 | | |
| Granite, broken | 1538 | 2,592 | Stone or gravel, 18.75-mm (3/4") size | 1602 | 2,700 | | |
| Gypsum | 2275 | 3,834 | | | | | |

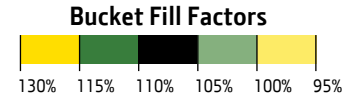

544K-II

| | | | | |
|---|--|---|---|----------------------|
| Engine | | 544K-II Z-BAR / HIGH-LIFT / POWERLLEL™ | | |
| Manufacturer and Model | John Deere PowerTech™ PVS 6068 | | | |
| Non-Road Emission Standard | EPA Final Tier 4/EU Stage IV | | | |
| Cylinders | 6 | | | |
| Valves Per Cylinder | 4 | | | |
| Displacement | 6.8 L (414 cu. in.) | | | |
| Net Peak Power (ISO 9249) | 121 kW (163 hp) at 1,800 rpm | | | |
| Net Peak Torque (ISO 9249) | 683 Nm (504 lb.-ft.) at 1,100 rpm | | | |
| Net Torque Rise | 45% | | | |
| Fuel System (electronically controlled) | High-pressure common rail | | | |
| Lubrication | Full-flow spin-on filter and integral cooler | | | |
| Aspiration | Turbocharged, charge air cooled | | | |
| Air Cleaner | Under-hood, dual-element dry type, restriction indicator in cab monitor for service | | | |
| Cooling | | | | |
| Fan Drive | Hydraulically driven, proportionally controlled, fan aft of coolers | | | |
| Electrical | | | | |
| Electrical System | 24 volt with 100-amp (130-amp optional) alternator | | | |
| Batteries (2 – 12 volt) | 950 CCA (each) | | | |
| Transmission System | | | | |
| Type | Countershaft-type PowerShift™ | | | |
| Torque Converter | Single stage, single phase | | | |
| Shift Control | Electronically modulated, adaptive, load and speed dependent | | | |
| Operator Interface | Steering-column or joystick-mounted F-N-R and gear-select lever; kick-down button on hydraulic lever | | | |
| Shift Modes | Manual/auto (1st–D or 2nd–D); Quick-Shift button with 2 selectable modes: kick-down or kick-up/down; and adaptive clutch cutoff | | | |
| | <i>Standard 5-Speed with Lockup Torque Converter</i> | | <i>Optional 5-Speed without Lockup Torque Converter</i> | |
| Maximum Travel Speeds (with 20.5 R 25 tires) | <i>Forward</i> | <i>Reverse</i> | <i>Forward</i> | <i>Reverse</i> |
| Range 1 | 5.8 km/h (3.6 mph) | 6.3 km/h (3.9 mph) | 5.2 km/h (3.2 mph) | 5.5 km/h (3.4 mph) |
| Range 2 | 12.0 km/h (7.5 mph) | 12.7 km/h (7.9 mph) | 10.9 km/h (6.8 mph) | 11.5 km/h (7.2 mph) |
| Range 3 | 18.6 km/h (11.6 mph) | 29.1 km/h (18.1 mph) | 16.6 km/h (10.3 mph) | 25.3 km/h (15.7 mph) |
| Range 4 | 27.7 km/h (17.2 mph) | N/A | 23.8 km/h (14.8 mph) | N/A |
| Range 5 | 40.0 km/h (24.9 mph) | N/A | 37.6 km/h (23.4 mph) | N/A |
| Axles/Brakes | | | | |
| Final Drives | Heavy-duty inboard-mounted planetary | | | |
| Differentials | Hydraulic locking front with conventional rear – standard; dual locking front and rear – optional | | | |
| Rear Axle Oscillation, Stop to Stop (with 20.5 R 25 tires) | 24 deg. (12 deg. each direction) | | | |
| Service Brakes (conform to ISO 3450) | Hydraulically actuated, spring-retracted, self-adjusting inboard sun-shaft mounted, oil cooled, single disc | | | |
| Parking Brakes (conform to ISO 3450) | Automatic spring applied, hydraulically released, driveline mounted, sealed wet multi disc | | | |
| Tires/Wheels (see page 26 for complete tire adjustments) | | | | |
| | <i>Tread Width</i> | <i>Width Over Tires</i> | | |
| Michelin 20.5 R 25, 1 Star L-3 | 1950 mm (76.8 in.) | 2546 mm (100.2 in.) | | |
| Serviceability | | | | |
| Refill Capacities | | | | |
| Fuel Tank (with lockable cap) | 298 L (79 gal.) | | | |
| Cooling System | 23.5 L (24.8 qt.) | | | |
| Diesel Exhaust Fluid (DEF) | 19 L (20 qt.) | | | |
| Engine Oil with Vertical Spin-On Filter | 19.5 L (20.6 qt.) | | | |
| Transmission Reservoir with Vertical Filter | 21.5 L (22.7 qt.) | | | |
| Axle Oil (front and rear, each) | 18 L (19 qt.) | | | |
| Hydraulic Reservoir and Filter | 118.7 L (31.35 gal.) | | | |
| Park Brake Oil (wet disc) | 0.3 L (10 oz.) | | | |
| Hydraulic System/Steering | | | | |
| Pump (loader and steering) | Variable-displacement, axial-piston pump; closed-center, pressure-compensating system | | | |
| Maximum Rated Flow at 6895 kPa (1,000 psi) and 2,350 rpm | 189 L/m (50 gpm) | | | |
| System Relief Pressure (loader and steering) | 25 166 kPa (3,650 psi) | | | |
| Loader Controls | 2-function valve; joystick control or fingertip controls; hydraulic-function enable/disable; optional 3rd- and 4th-function valve with auxiliary lever | | | |
| Steering (conforms to ISO 5010) | Steering-column-mounted, twist-grip shift lever; Quick-Shift button on hydraulic lever | | | |
| Type | Power, fully hydraulic | | | |
| Articulation Angle | 80-deg. arc (40 deg. each direction) | | | |
| Turning Radius (measured to centerline of outside tire) | 5.0 m (16 ft. 5 in.) | | | |



| Hydraulic System/Steering (continued) | 544K-II Z-BAR / HIGH-LIFT / POWERLLEL | |
|---------------------------------------|---------------------------------------|-----------|
| | Z-Bar / High-Lift | Powerllel |
| Hydraulic Cycle Times | | |
| Raise | 5.8 sec. | 5.8 sec. |
| Dump | 1.2 sec. | 1.2 sec. |
| Lower (float down) | 3.2 sec. | 2.5 sec. |
| Total | 10.2 sec. | 9.5 sec. |

Dimensions and Specifications with Pin-On Bucket

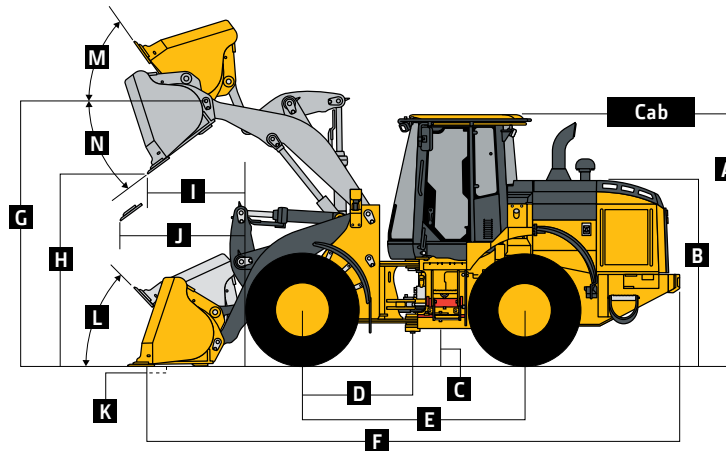

544K-II Z-BAR AND HIGH-LIFT LOADERS WITH PIN-ON BUCKET

| Dimensions with Bucket | Z-Bar | Z-Bar | High-Lift | High-Lift |
|---|---|---|---|---|
| | Narrow 2.3-m ³ (3.0 cu. yd.) general-purpose with bolt-on edge | Wide 2.3-m ³ (3.0 cu. yd.) general-purpose with bolt-on edge | Narrow 2.3-m ³ (3.0 cu. yd.) general-purpose with bolt-on edge | Wide 2.3-m ³ (3.0 cu. yd.) general-purpose with bolt-on edge |
| A Height to Top of Cab | 3.24 m (10 ft. 8 in.) | 3.24 m (10 ft. 8 in.) | 3.24 m (10 ft. 8 in.) | 3.24 m (10 ft. 8 in.) |
| B Hood Height | 2.37 m (7 ft. 9 in.) | 2.37 m (7 ft. 9 in.) | 2.37 m (7 ft. 9 in.) | 2.37 m (7 ft. 9 in.) |
| C Ground Clearance | 0.40 m (15.7 in.) | 0.40 m (15.7 in.) | 0.40 m (15.7 in.) | 0.40 m (15.7 in.) |
| D Length from Centerline to Front Axle | 1.45 m (4 ft. 9 in.) | 1.45 m (4 ft. 9 in.) | 1.45 m (4 ft. 9 in.) | 1.45 m (4 ft. 9 in.) |
| E Wheelbase | 2.93 m (9 ft. 7 in.) | 2.93 m (9 ft. 7 in.) | 2.93 m (9 ft. 7 in.) | 2.93 m (9 ft. 7 in.) |
| F Overall Length, Bucket on Ground | 7.43 m (24 ft. 4 in.) | 7.34 m (24 ft. 1 in.) | 7.75 m (25 ft. 5 in.) | 7.67 m (25 ft. 2 in.) |
| G Height to Hinge Pin, Fully Raised | 3.82 m (12 ft. 6 in.) | 3.82 m (12 ft. 6 in.) | 4.17 m (13 ft. 8 in.) | 4.17 m (13 ft. 8 in.) |
| H Dump Clearance, 45 deg., Full Height | 2.76 m (9 ft. 1 in.) | 2.82 m (9 ft. 3 in.) | 3.11 m (10 ft. 3 in.) | 3.17 m (10 ft. 5 in.) |
| I Reach, 45-deg. Dump, Full Height | 0.99 m (3 ft. 3 in.) | 0.93 m (3 ft. 1 in.) | 0.99 m (3 ft. 3 in.) | 0.93 m (3 ft. 1 in.) |
| J Reach, 45-deg. Dump, 2.13-m (7 ft. 0 in.) Clearance | 1.46 m (4 ft. 10 in.) | 1.44 m (4 ft. 9 in.) | 1.76 m (5 ft. 9 in.) | 1.73 m (5 ft. 8 in.) |
| K Maximum Digging Depth | 95 mm (3.72 in.) | 95 mm (3.72 in.) | 221 mm (8.7 in.) | 221 mm (8.7 in.) |
| L Maximum Rollback at Ground Level | 42 deg. | 42 deg. | 37 deg. | 37 deg. |
| M Maximum Rollback, Boom Fully Raised | 55 deg. | 55 deg. | 50 deg. | 50 deg. |
| N Maximum Bucket Dump Angle, Fully Raised | 49 deg. | 49 deg. | 46 deg. | 46 deg. |
| Loader Clearance Circle, Bucket Carry Position | 11.65 m (38 ft. 3 in.) | 11.72 m (38 ft. 5 in.) | 11.96 m (39 ft. 3 in.) | 12.03 m (39 ft. 6 in.) |
| Specifications with Bucket | | | | |
| Capacity, Heaped | 2.3 m ³ (3.0 cu. yd.) | 2.3 m ³ (3.0 cu. yd.) | 2.3 m ³ (3.0 cu. yd.) | 2.3 m ³ (3.0 cu. yd.) |
| Capacity, Struck | 2.0 m ³ (2.6 cu. yd.) | 2.0 m ³ (2.6 cu. yd.) | 2.0 m ³ (2.6 cu. yd.) | 2.0 m ³ (2.6 cu. yd.) |
| Bucket Weight with Bolt-On Cutting Edge | 1066 kg (2,350 lb.) | 1048 kg (2,310 lb.) | 1066 kg (2,350 lb.) | 1048 kg (2,310 lb.) |
| Bucket Width | 2.54 m (8 ft. 4 in.) | 2.69 m (8 ft. 10 in.) | 2.54 m (8 ft. 4 in.) | 2.69 m (8 ft. 10 in.) |
| Breakout Force | 10 115 kg (22,300 lb.) | 10 869 kg (23,962 lb.) | 9352 kg (20,618 lb.) | 10 050 kg (22,156 lb.) |
| Tipping Load, Straight, No Tire Deflection | 11 106 kg (24,484 lb.) | 11 163 kg (24,610 lb.) | 9565 kg (21,087 lb.) | 9623 kg (21,215 lb.) |
| Tipping Load, Straight, with Tire Deflection | 10 530 kg (23,215 lb.) | 10 590 kg (23,347 lb.) | 9120 kg (20,106 lb.) | 9180 kg (20,238 lb.) |
| Tipping Load, 40-deg. Full Turn, No Tire Deflection | 9637 kg (21,246 lb.) | 9690 kg (21,363 lb.) | 8273 kg (18,239 lb.) | 8325 kg (18,353 lb.) |
| Tipping Load, 40-deg. Full Turn, with Tire Deflection | 8895 kg (19,610 lb.) | 8952 kg (19,736 lb.) | 7689 kg (16,951 lb.) | 7746 kg (17,077 lb.) |
| Rated Operating Load, 50% Full-Turn Tipping Load, No Tire Deflection (conforms to ISO 14397-1)* | 4818 kg (10,622 lb.) | 4845 kg (10,681 lb.) | 4136 kg (9,118 lb.) | 4162 kg (9,176 lb.) |
| Rated Operating Load, 50% Full-Turn Tipping Load, with Tire Deflection (conforms to ISO 14397-1)* | 4447 kg (9,804 lb.) | 4476 kg (9,868 lb.) | 3844 kg (8,475 lb.) | 3873 kg (8,538 lb.) |
| Operating Weight | 13 217 kg (29,138 lb.) | 13 200 kg (29,101 lb.) | 13 352 kg (29,436 lb.) | 13 335 kg (29,399 lb.) |

Loader operating information is based on machine with identified linkage and standard equipment, PowerTech PVS 6068 (EPA Final Tier 4/EU Stage IV) engine, ROPS cab, rear cast bumper/counterweight, transmission side-frame guards, bottom guards, standard tires, full fuel tank, and 79-kg (175 lb.) operator. This information is affected by changes in tires, ballast, and different attachments.

*Rated operating capacity based on Deere attachments only.

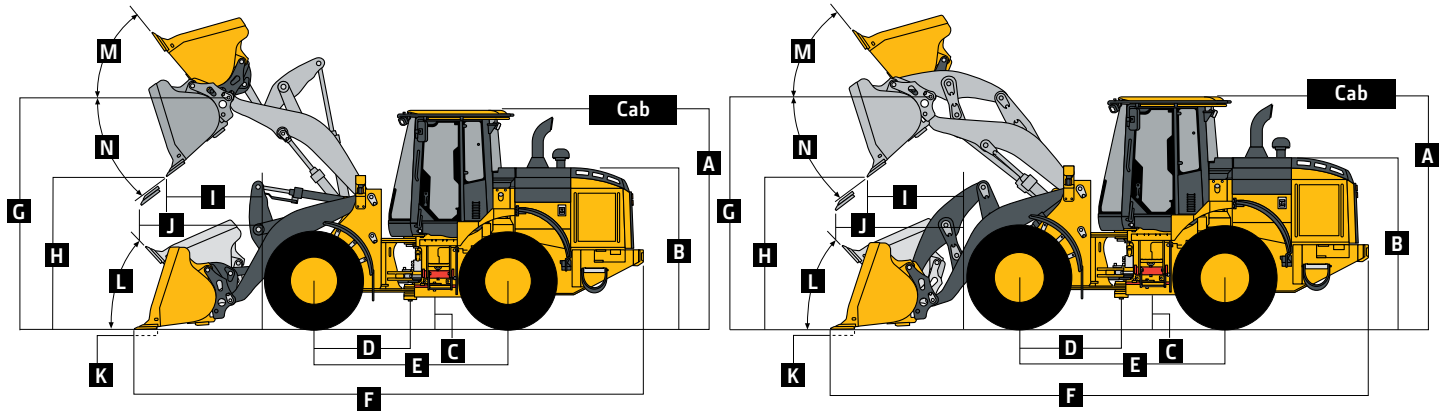

544K-II Z-BAR AND HIGH-LIFT LOADERS WITH
QUICK-COUPLER AND HOOK-ON BUCKET

544K-II POWERLEL LOADER WITH
QUICK-COUPLER AND HOOK-ON BUCKET

| | Z-Bar | Z-Bar | High-Lift | High-Lift | Powerlrel | Powerlrel |
|---|--|---|--|---|--|---|
| Dimensions with Bucket | 2.3-m ³ (3.0 cu. yd.) general-purpose with bolt-on edge | 3.4-m ³ (4.5 cu. yd.) light-material with bolt-on edge | 2.3-m ³ (3.0 cu. yd.) general-purpose with bolt-on edge | 3.4-m ³ (4.5 cu. yd.) light-material with bolt-on edge | 2.3-m ³ (3.0 cu. yd.) general-purpose with bolt-on edge | 3.4-m ³ (4.5 cu. yd.) light-material with bolt-on edge |
| A Height to Top of Cab | 3.24 m (10 ft. 8 in.) | 3.24 m (10 ft. 8 in.) | 3.24 m (10 ft. 8 in.) | 3.24 m (10 ft. 8 in.) | 3.24 m (10 ft. 8 in.) | 3.24 m (10 ft. 8 in.) |
| B Hood Height | 2.375 m (7 ft. 9 in.) | 2.375 m (7 ft. 9 in.) | 2.375 m (7 ft. 9 in.) | 2.375 m (7 ft. 9 in.) | 2.375 m (7 ft. 9 in.) | 2.375 m (7 ft. 9 in.) |
| C Ground Clearance | 0.40 m (15.7 in.) | 0.40 m (15.7 in.) | 0.40 m (15.7 in.) | 0.40 m (15.7 in.) | 0.40 m (15.7 in.) | 0.40 m (15.7 in.) |
| D Length from Centerline to Front Axle | 1.45 m (4 ft. 9 in.) | 1.45 m (4 ft. 9 in.) | 1.45 m (4 ft. 9 in.) | 1.45 m (4 ft. 9 in.) | 1.45 m (4 ft. 9 in.) | 1.45 m (4 ft. 9 in.) |
| E Wheelbase | 2.93 m (9 ft. 7 in.) | 2.93 m (9 ft. 7 in.) | 2.93 m (9 ft. 7 in.) | 2.93 m (9 ft. 7 in.) | 2.93 m (9 ft. 7 in.) | 2.93 m (9 ft. 7 in.) |
| F Overall Length, Bucket on Ground | 7.57 m (24 ft. 10 in.) | 7.87 m (25 ft. 10 in.) | 7.90 m (25 ft. 11 in.) | 8.02 m (26 ft. 4 in.) | 7.69 m (25 ft. 3 in.) | 7.89 m (25 ft. 11 in.) |
| G Height to Hinge Pin, Fully Raised | 3.81 m (12 ft. 6 in.) | 3.81 m (12 ft. 6 in.) | 4.13 m (13 ft. 7 in.) | 4.13 m (13 ft. 7 in.) | 3.85 m (12 ft. 8 in.) | 3.85 m (12 ft. 8 in.) |
| H Dump Clearance, 45 deg., Full Height | 2.66 m (8 ft. 9 in.) | 2.40 m (7 ft. 10 in.) | 3.01 m (9 ft. 10 in.) | 2.74 m (8 ft. 11 in.) | 2.68 m (8 ft. 9 in.) | 2.47 m (8 ft. 1 in.) |
| I Reach, 45-deg. Dump, Full Height | 1.05 m (3 ft. 5 in.) | 1.20 m (3 ft. 11 in.) | 1.05 m (3 ft. 5 in.) | 1.22 m (4 ft. 0 in.) | 1.09 m (3 ft. 7 in.) | 1.26 m (4 ft. 2 in.) |
| J Reach, 45-deg. Dump, 2.13-m (7 ft. 0 in.) Clearance | 1.46 m (4 ft. 10 in.) | 1.43 m (4 ft. 8 in.) | 1.77 m (5 ft. 10 in.) | 1.75 m (5 ft. 9 in.) | 1.51 m (5 ft. 0 in.) | 1.56 m (5 ft. 1 in.) |
| K Maximum Digging Depth | 138 mm (5.4 in.) | 230 mm (9.0 in.) | 227 mm (8.9 in.) | 311 mm (12.2 in.) | 127 mm (5.0 in.) | 216 mm (8.5 in.) |
| L Maximum Rollback at Ground Level | 41 deg. | 41 deg. | 41 deg. | 41 deg. | 42 deg. | 44 deg. |
| M Maximum Rollback, Boom Fully Raised | 54 deg. | 55 deg. | 48 deg. | 50 deg. | 51 deg. | 54 deg. |
| N Maximum Bucket Dump Angle, Fully Raised | 51 deg. | 49 deg. | 47 deg. | 45 deg. | 50 deg. | 47 deg. |
| Loader Clearance Circle, Bucket Carry Position | 11.88 m (39 ft. 0 in.) | 12.24 m (40 ft. 2 in.) | 12.19 m (40 ft. 0 in.) | 12.58 m (41 ft. 3 in.) | 12.10 m (39 ft. 8 in.) | 12.35 m (40 ft. 6 in.) |
| Specifications with Bucket | | | | | | |
| Capacity, Heaped | 2.3 m ³ (3.0 cu. yd.) | 3.4 m ³ (4.5 cu. yd.) | 2.3 m ³ (3.0 cu. yd.) | 3.4 m ³ (4.5 cu. yd.) | 2.3 m ³ (3.0 cu. yd.) | 3.4 m ³ (4.5 cu. yd.) |
| Capacity, Struck | 2.0 m ³ (2.6 cu. yd.) | 2.9 m ³ (3.8 cu. yd.) | 2.0 m ³ (2.6 cu. yd.) | 2.9 m ³ (3.8 cu. yd.) | 2.0 m ³ (2.6 cu. yd.) | 2.9 m ³ (3.8 cu. yd.) |
| Bucket Weight with Bolt-On Cutting Edge | 1450 kg (3,197 lb.) | 1745 kg (3,847 lb.) | 1450 kg (3,197 lb.) | 1745 kg (3,847 lb.) | 1428 kg (3,148 lb.) | 1724 kg (3,801 lb.) |
| Bucket Width | 2.69 m (8 ft. 10 in.) | 2.89 m (9 ft. 6 in.) | 2.69 m (8 ft. 10 in.) | 2.89 m (9 ft. 6 in.) | 2.69 m (8 ft. 10 in.) | 2.69 m (8 ft. 10 in.) |
| Breakout Force | 8992 kg (19,824 lb.) | 7375 kg (16,259 lb.) | 8294 kg (18,285 lb.) | 6847 kg (15,095 lb.) | 8604 kg (18,968 lb.) | 7861 kg (17,330 lb.) |
| Tipping Load, Straight, No Tire Deflection | 9877 kg (21,775 lb.) | 9290 kg (20,481 lb.) | 8532 kg (18,810 lb.) | 7986 kg (17,606 lb.) | 9054 kg (19,961 lb.) | 8472 kg (18,677 lb.) |
| Tipping Load, Straight, with Tire Deflection | 9378 kg (20,675 lb.) | 8796 kg (19,392 lb.) | 8139 kg (17,943 lb.) | 7602 kg (16,759 lb.) | 8613 kg (18,988 lb.) | 8043 kg (17,732 lb.) |
| Tipping Load, 40-deg. Full Turn, No Tire Deflection | 8520 kg (18,783 lb.) | 7968 kg (17,566 lb.) | 7328 kg (16,155 lb.) | 6812 kg (15,018 lb.) | 7788 kg (17,170 lb.) | 7248 kg (15,979 lb.) |
| Tipping Load, 40-deg. Full Turn, with Tire Deflection | 7869 kg (17,348 lb.) | 7326 kg (16,151 lb.) | 6807 kg (15,007 lb.) | 6297 kg (13,882 lb.) | 7209 kg (15,893 lb.) | 6666 kg (14,696 lb.) |
| Rated Operating Load, 50% Full-Turn Tipping Load, No Tire Deflection (conforms to ISO 14397-1)* | 4260 kg (9,392 lb.) | 3984 kg (8,783 lb.) | 3664 kg (8,078 lb.) | 3406 kg (7,509 lb.) | 3894 kg (8,585 lb.) | 3624 kg (7,989 lb.) |
| Rated Operating Load, 50% Full-Turn Tipping Load, with Tire Deflection (conforms to ISO 14397-1)* | 3934 kg (8,673 lb.) | 3663 kg (8,075 lb.) | 3403 kg (7,502 lb.) | 3148 kg (6,940 lb.) | 3604 kg (7,945 lb.) | 3333 kg (7,348 lb.) |
| Operating Weight | 13 601 kg (29,985 lb.) | 13 896 kg (30,635 lb.) | 13 736 kg (30,283 lb.) | 14 031 kg (30,933 lb.) | 14 327 kg (31,586 lb.) | 14 622 kg (32,236 lb.) |

Loader operating information is based on machine with identified linkage and standard equipment, PowerTech PVS 6068 (EPA Final Tier 4/EU Stage IV) engine, ROPS cab, rear cast bumper/counterweight, transmission side-frame guards, bottom guards, standard tires, full fuel tank, and 79-kg (175 lb.) operator. This information is affected by changes in tires, ballast, and different attachments.

*Rated operating capacity based on Deere attachments only.

Dimensions and Specifications with Hi-Vis Coupler and Construction Forks 544K-II Z-BAR / HIGH-LIFT / POWERLLEL

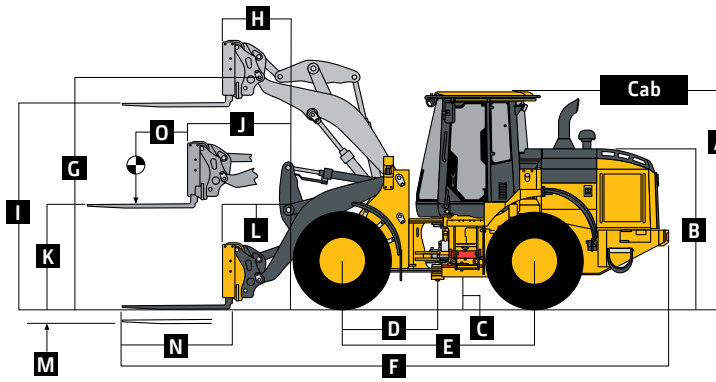

544K-II Z-BAR AND HIGH-LIFT LOADERS WITH QUICK-COUPLER AND HOOK-ON CONSTRUCTION FORKS

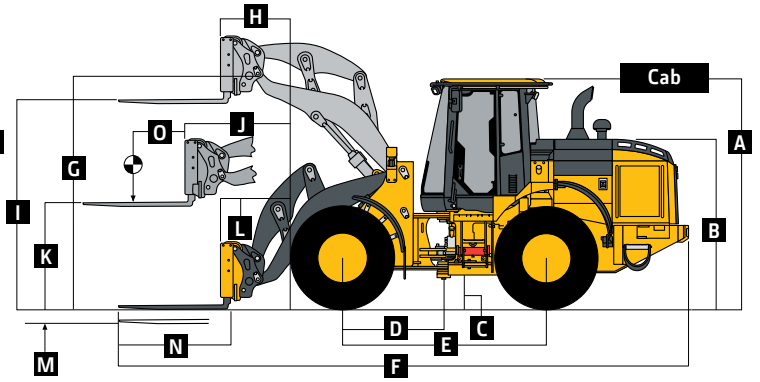

544K-II POWERLLEL LOADER WITH QUICK-COUPLER AND HOOK-ON CONSTRUCTION FORKS

| | Z-Bar | Z-Bar | High-Lift | High-Lift | Powerllel | Powerllel |
|--|--------------------------------|--------------------------------|--------------------------------|--------------------------------|--------------------------------|--------------------------------|
| Dimensions with Forks | 1.22-m (48 in.) tine length | 1.52-m (60 in.) tine length | 1.22-m (48 in.) tine length | 1.52-m (60 in.) tine length | 1.22-m (48 in.) tine length | 1.52-m (60 in.) tine length |
| A Height to Top of Cab | 3.24 m (10 ft. 8 in.) | 3.24 m (10 ft. 8 in.) | 3.24 m (10 ft. 8 in.) | 3.24 m (10 ft. 8 in.) | 3.24 m (10 ft. 8 in.) | 3.24 m (10 ft. 8 in.) |
| B Hood Height | 2.30 m (7 ft. 7 in.) | 2.30 m (7 ft. 7 in.) | 2.30 m (7 ft. 7 in.) | 2.30 m (7 ft. 7 in.) | 2.30 m (7 ft. 7 in.) | 2.30 m (7 ft. 7 in.) |
| C Ground Clearance | 0.40 m (15.7 in.) | 0.40 m (15.7 in.) | 0.40 m (15.7 in.) | 0.40 m (15.7 in.) | 0.40 m (15.7 in.) | 0.40 m (15.7 in.) |
| D Length from Centerline to Front Axle | 1.45 m (4 ft. 9 in.) | 1.45 m (4 ft. 9 in.) | 1.45 m (4 ft. 9 in.) | 1.45 m (4 ft. 9 in.) | 1.45 m (4 ft. 9 in.) | 1.45 m (4 ft. 9 in.) |
| E Wheelbase | 2.93 m (9 ft. 7 in.) | 2.93 m (9 ft. 7 in.) | 2.93 m (9 ft. 7 in.) | 2.93 m (9 ft. 7 in.) | 2.93 m (9 ft. 7 in.) | 2.93 m (9 ft. 7 in.) |
| F Overall Length, Forks on Ground | 7.89 m (25 ft. 11 in.) | 8.19 m (26 ft. 10 in.) | 8.22 m (27 ft. 0 in.) | 8.52 m (27 ft. 11 in.) | 7.99 m (26 ft. 3 in.) | 8.29 m (27 ft. 2 in.) |
| G Height to Hinge Pin, Fully Raised | 3.81 m (12 ft. 6 in.) | 3.81 m (12 ft. 6 in.) | 4.13 m (13 ft. 7 in.) | 4.13 m (13 ft. 7 in.) | 3.85 m (12 ft. 8 in.) | 3.85 m (12 ft. 8 in.) |
| H Reach, Fully Raised | 0.75 m (29.5 in.) | 0.75 m (29.5 in.) | 0.75 m (29.5 in.) | 0.75 m (29.5 in.) | 0.79 m (31 in.) | 0.79 m (31 in.) |
| I Fork Height, Fully Raised | 3.59 m (11 ft. 9 in.) | 3.59 m (11 ft. 9 in.) | 3.94 m (12 ft. 11 in.) | 3.94 m (12 ft. 11 in.) | 3.64 m (11 ft. 11 in.) | 3.64 m (11 ft. 11 in.) |
| J Maximum Reach, Fork Level | 1.54 m (5 ft. 1 in.) | 1.54 m (5 ft. 1 in.) | 1.80 m (5 ft. 11 in.) | 1.80 m (5 ft. 11 in.) | 1.61 m (5 ft. 4 in.) | 1.61 m (5 ft. 4 in.) |
| K Fork Height, Maximum Reach | 1.72 m (5 ft. 8 in.) | 1.72 m (5 ft. 8 in.) | 1.72 m (5 ft. 8 in.) | 1.72 m (5 ft. 8 in.) | 1.75 m (5 ft. 9 in.) | 1.75 m (5 ft. 9 in.) |
| L Reach, Ground Level | 0.95 m (3 ft. 2 in.) | 0.95 m (3 ft. 2 in.) | 1.28 m (4 ft. 3 in.) | 1.28 m (4 ft. 3 in.) | 0.99 m (3 ft. 3 in.) | 0.99 m (3 ft. 3 in.) |
| M Depth Below Ground | 13 mm (0.5 in.) | 13 mm (0.5 in.) | 96 mm (3.8 in.) | 96 mm (3.8 in.) | 1 mm (0.04 in.) | 1 mm (0.04 in.) |
| N Tine Length | 1.22 m (48 in.) | 1.52 m (60 in.) | 1.22 m (48 in.) | 1.52 m (60 in.) | 1.22 m (48 in.) | 1.52 m (60 in.) |
| O Load Position, 50% Tine Length | 0.61 m (24 in.) | 0.76 m (30 in.) | 0.61 m (24 in.) | 0.76 m (30 in.) | 0.61 m (24 in.) | 0.76 m (30 in.) |
| Specifications with Forks | | | | | | |
| Tipping Load, Straight, No Tire Deflection | 7739 kg (17,061 lb.) | 7308 kg (16,111 lb.) | 7024 kg (15,485 lb.) | 6657 kg (14,676 lb.) | 7359 kg (16,224 lb.) | 6963 kg (15,351 lb.) |
| Tipping Load, Straight, with Tire Deflection | 7533 kg (16,607 lb.) | 7119 kg (15,695 lb.) | 6843 kg (15,086 lb.) | 6492 kg (14,312 lb.) | 7158 kg (15,781 lb.) | 6780 kg (14,947 lb.) |
| Tipping Load, 40-deg. Full Turn, No Tire Deflection | 6712 kg (14,797 lb.) | 6332 kg (13,960 lb.) | 6073 kg (13,389 lb.) | 5749 kg (12,674 lb.) | 6366 kg (14,035 lb.) | 6018 kg (13,267 lb.) |
| Tipping Load, 40-deg. Full Turn, with Tire Deflection | 6432 kg (14,180 lb.) | 6075 kg (13,393 lb.) | 5829 kg (12,851 lb.) | 5532 kg (12,196 lb.) | 6096 kg (13,439 lb.) | 5766 kg (12,712 lb.) |
| Rated Operating Load, 50% Full-Turn Tipping Load, with Tire Deflection (conforms to ISO 14397-1 and SAE J1197)* | 3216 kg (7,090 lb.) | 3037 kg (6,695 lb.) | 2914 kg (6,424 lb.) | 2766 kg (6,098 lb.) | 3048 kg (6,720 lb.) | 2883 kg (6,356 lb.) |
| Rated Operating Load, Rough Terrain, 60% Full-Turn Tipping Load, with Tire Deflection (conforms to EN474-3)* | 3859 kg (8,508 lb.) | 3645 kg (8,036 lb.) | 3497 kg (7,710 lb.) | 3319 kg (7,317 lb.) | 3658 kg (8,064 lb.) | 3460 kg (7,628 lb.) |
| Rated Operating Load, Firm and Level Ground, 80% Full-Turn Tipping Load, with Tire Deflection (conforms to EN474-3)* | 5146 kg (11,345 lb.) | 4860 kg (10,714 lb.) | 4663 kg (10,280 lb.) | 9758 kg (10,041 lb.) | 4877 kg (10,752 lb.) | 4613 kg (10,170 lb.) |
| Operating Weight | 13 205 kg (29,112 lb.) | 13 248 kg (29,207 lb.) | 13 340 kg (29,410 lb.) | 13 383 kg (29,504 lb.) | 13 931 kg (30,713 lb.) | 13 974 kg (30,807 lb.) |

Loader operating information is based on machine with identified linkage and standard equipment, PowerTech PVS 6068 (EPA Final Tier 4/EU Stage IV) engine, ROPS cab, rear cast bumper/counterweight, transmission side-frame guards, bottom guards, standard tires, full fuel tank, and 79-kg (175 lb.) operator. This information is affected by changes in tires, ballast, and different attachments.

*Rated operating capacity based on Deere attachments only.

Adjustments to Operating Weights and Tipping Loads with Buckets

544K-II Z-BAR / HIGH-LIFT / POWERLLEL

Adjustments to operating weights, tipping loads, and tires are based on Z-Bar machine with pin-on 2.3-m³ (3.0 cu. yd.) general-purpose bucket with bolt-on cutting edge, ROPS cab, rear cast bumper/counterweight, transmission side-frame guards, bottom guards, standard tires, full fuel tank, and 79-kg (175 lb.) operator*

| Add (+) or deduct (-) kg (lb.) as indicated for loaders with 3-piece rims | Operating Weight | Tipping Load, Straight | Tipping Load, 40-deg. Full Turn | Tread Width | Width Over Tires | Vertical Height |
|---|-------------------------|--------------------------|---------------------------------|--------------------|-------------------|--------------------|
| John Deere PowerTech PVS 6068 | 0 kg (0 lb.) | 0 kg (0 lb.) | 0 kg (0 lb.) | N/A | N/A | N/A |
| John Deere PowerTech E 6068H | | | | | | |
| Z-Bar | -96 kg (-212 lb.) | -3 kg (-7 lb.) | -18 kg (-40 lb.) | N/A | N/A | N/A |
| High-Lift/Powerllel | -112 kg (-245 lb.) | -37 kg (-82 lb.) | -45 kg (-99 lb.) | N/A | N/A | N/A |
| Michelin 20.5 R 25, 1 Star L-3 | 0 kg (0 lb.) | 0 kg (0 lb.) | 0 kg (0 lb.) | 0 mm (0 in.) | 0 mm (0 in.) | 0 mm (0 in.) |
| Bridgestone 20.5 R 25, 1 Star L-3 | +44 kg (+97 lb.) | +32 kg (+71 lb.) | +28 kg (+62 lb.) | 0 mm (0 in.) | -5 mm (-0.2 in.) | -5 mm (-0.2 in.) |
| Titan 20.5 R 25, 1 Star L-3 | -4 kg (-9 lb.) | -3 kg (-7 lb.) | -3 kg (-7 lb.) | 0 mm (0 in.) | -5 mm (-0.2 in.) | -5 mm (-0.2 in.) |
| Michelin 20.5 R 25, 1 Star L-2 | -172 kg (-379 lb.) | -125 kg (-276 lb.) | -110 kg (-242 lb.) | 0 mm (0 in.) | -5 mm (-0.2 in.) | -5 mm (-0.2 in.) |
| Bridgestone 20.5 R 25, 1 Star L-2 | -80 kg (-176 lb.) | -58 kg (-128 lb.) | -51 kg (-112 lb.) | 0 mm (0 in.) | -5 mm (-0.2 in.) | -5 mm (-0.2 in.) |
| Titan 20.5 R 25, 1 Star L-2 | -100 kg (-220 lb.) | -72 kg (-159 lb.) | -64 kg (-141 lb.) | 0 mm (0 in.) | -5 mm (-0.2 in.) | -5 mm (-0.2 in.) |
| Titan 20.5-25, 16 PR L-2 | -260 kg (-573 lb.) | -188 kg (-415 lb.) | -166 kg (-366 lb.) | 0 mm (0 in.) | -2 mm (-0.1 in.) | +3 mm (+0.1 in.) |
| Firestone 20.5-25, 16 PR L-2 | -280 kg (-617 lb.) | -203 kg (-448 lb.) | -179 kg (-395 lb.) | 0 mm (0 in.) | -2 mm (-0.1 in.) | +3 mm (+0.1 in.) |
| Firestone 20.5-25, 12 PR L-2 | -316 kg (-697 lb.) | -229 kg (-505 lb.) | -202 kg (-445 lb.) | 0 mm (0 in.) | -2 mm (-0.1 in.) | +3 mm (+0.1 in.) |
| Titan 20.5-25, 12 PR L-2 | -280 kg (-617 lb.) | -203 kg (-448 lb.) | -179 kg (-395 lb.) | 0 mm (0 in.) | -2 mm (-0.1 in.) | +3 mm (+0.1 in.) |
| Firestone 20.5-25, 16 PR L-3 | -252 kg (-556 lb.) | -183 kg (-403 lb.) | -161 kg (-355 lb.) | 0 mm (0 in.) | -2 mm (-0.1 in.) | +9 mm (+0.4 in.) |
| Michelin 20.5 R 25 L2 Sno-Plus | -100 kg (-220 lb.) | -72 kg (-159 lb.) | -64 kg (-141 lb.) | 0 mm (0 in.) | +7 mm (+0.28 in.) | -22 mm (-0.9 in.) |
| 620/75R26 MegaXbib [®] | -200 kg (-440 lb.) | -145 kg (-320 lb.) | -128 kg (-282 lb.) | +189 mm (+7.4 in.) | +61 mm (+2.4 in.) | +22 mm (+0.86 in.) |
| CaCl ₂ in 20.5-25, L-3 Rear Tires, 75% Fill | +825 kg (+1,820 lb.) | +1010 kg (+2,227 lb.) | +891 kg (+1,964 lb.) | N/A | N/A | N/A |

*May change based on vehicle configuration, weight, or tire-pressure adjustments.

[‡]Equipped with 1-piece rims.

[®]Requires 8-deg. rear axle stops.

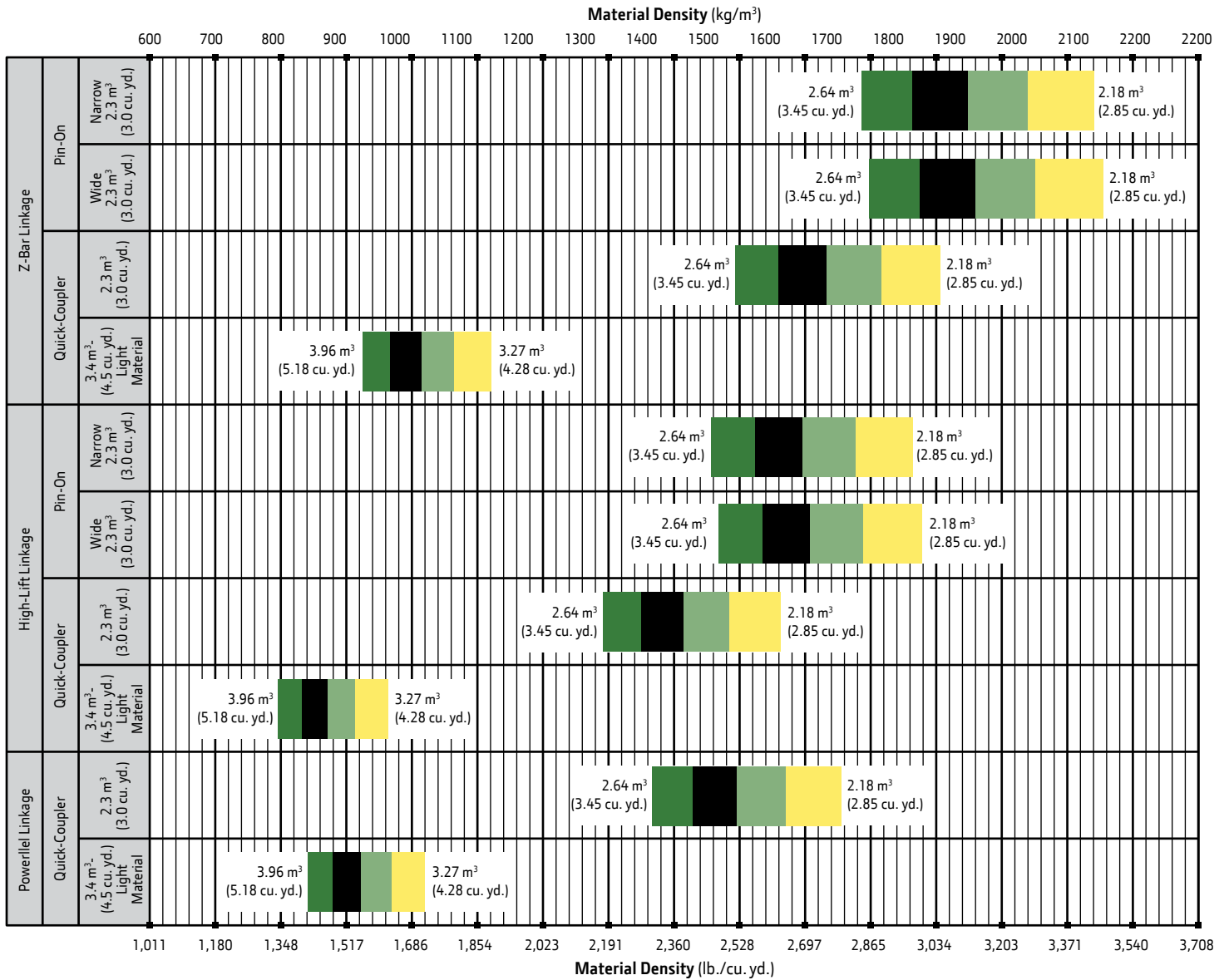

| LOOSE MATERIALS | | kg/m³ | lb./cu. yd. | LOOSE MATERIALS | | kg/m³ | lb./cu. yd. |
|----------------------------------|------|-------|---------------------------------------|-----------------|-------|-------|-------------|
| Chips, pulpwood | 288 | 486 | Limestone, coarse, sized | 1570 | 2,646 | | |
| Cinders (coal, ashes, clinkers) | 673 | 1,134 | Limestone, mixed sizes | 1682 | 2,835 | | |
| Clay and gravel, dry | 1602 | 2,700 | Limestone, pulverized or crushed | 1362 | 2,295 | | |
| Clay, compact, solid | 1746 | 2,943 | Sand, damp | 2083 | 3,510 | | |
| Clay, dry in lump loose | 1009 | 1,701 | Sand, dry | 1762 | 2,970 | | |
| Clay, excavated in water | 1282 | 2,160 | Sand, voids, full of water | 2083 | 3,510 | | |
| Coal, anthracite, broken, loose | 865 | 1,458 | Sandstone, quarried | 1314 | 2,214 | | |
| Coal, bituminous, moderately wet | 801 | 1,350 | Shale, broken crushed | 1362 | 2,295 | | |
| Earth, common loam, dry | 1218 | 2,052 | Slag, furnace granulated | 1955 | 3,294 | | |
| Earth, mud, packed | 1843 | 3,105 | Stone or gravel, 37.5 to 87.5-mm | 1442 | 2,430 | | |
| Granite, broken | 1538 | 2,592 | (1.5 to 3.5") size | 1602 | 2,700 | | |
| Gypsum | 2275 | 3,834 | Stone or gravel, 18.75-mm (3/4") size | | | | |

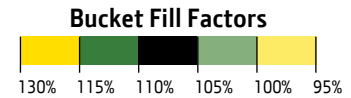

624K-II

| Engine | | 624K-II Z-BAR / HIGH-LIFT / POWERLLEL™ / TOOL CARRIER | | | |
|---|---|--|---|----------------------|--|
| Manufacturer and Model | John Deere PowerTech™ PVX 6068 | | | | |
| Non-Road Emission Standard | EPA Final Tier 4/EU Stage IV | | | | |
| Cylinders | 6 | | | | |
| Valves Per Cylinder | 4 | | | | |
| Displacement | 6.8 L (414 cu. in.) | | | | |
| Net Peak Power (ISO 9249) | 139 kW (186 hp) at 1,800 rpm | | | | |
| Net Peak Torque (ISO 9249) | 826 Nm (609 lb.-ft.) at 1,300 rpm | | | | |
| Net Torque Rise | 64% | | | | |
| Fuel System (electronically controlled) | High-pressure common rail | | | | |
| Lubrication | Full-flow spin-on filter and integral cooler | | | | |
| Aspiration | Turbocharged, charge air cooled | | | | |
| Air Cleaner | Under-hood, dual-element dry type, restriction indicator in cab monitor for service | | | | |
| Fan Drive | Hydraulically driven, proportionally controlled, fan aft of coolers | | | | |
| Electrical System | 24 volt with 130-amp alternator | | | | |
| Batteries (2 – 12 volt) | 950 CCA (each) | | | | |
| Transmission System | | | | | |
| Type | Countershaft-type PowerShift™ | | | | |
| Torque Converter | Single stage, single phase | | | | |
| Shift Control | Electronically modulated, adaptive, load and speed dependent | | | | |
| Operator Interface | Steering-column or joystick-mounted F-N-R and gear-select lever; quick-shift button on hydraulic lever | | | | |
| Shift Modes | Manual/auto (1st–D or 2nd–D); Quick-Shift button with 2 selectable modes: kick-down or kick-up/down; and adaptive clutch cutoff | | | | |
| | <i>Standard 5-Speed with Lockup Torque Converter</i> | | <i>Optional 5-Speed without Lockup Torque Converter</i> | | |
| Maximum Travel Speeds (with 20.5 R 25 tires) | <i>Forward</i> | <i>Reverse</i> | <i>Forward</i> | <i>Reverse</i> | |
| Range 1 | 6.2 km/h (3.85 mph) | 6.6 km/h (4.1 mph) | 6.4 km/h (4.0 mph) | 6.7 km/h (4.2 mph) | |
| Range 2 | 11.1 km/h (6.9 mph) | 11.8 km/h (7.3 mph) | 11.3 km/h (7.0 mph) | 11.9 km/h (7.4 mph) | |
| Range 3 | 17.1 km/h (10.6 mph) | 28.1 km/h (17.5 mph) | 17.0 km/h (10.6 mph) | 26.5 km/h (16.5 mph) | |
| Range 4 | 26.7 km/h (16.6 mph) | N/A | 25.4 km/h (15.8 mph) | N/A | |
| Range 5 | 40.0 km/h (24.9 mph) | N/A | 36.3 km/h (22.5 mph) | N/A | |
| Axles/Brakes | | | | | |
| Final Drives | Heavy-duty inboard-mounted planetary | | | | |
| Differentials | Hydraulic locking front with conventional rear – standard; dual locking front and rear – optional | | | | |
| Rear Axle Oscillation, Stop to Stop (with 20.5 R 25 tires) | 24 deg. (12 deg. each direction) | | | | |
| Service Brakes (conform to ISO 3450) | Hydraulically actuated, spring-retracted, self-adjusting, inboard sun-shaft mounted, oil-cooled, single disc | | | | |
| Parking Brakes (conform to ISO 3450) | Automatic spring-applied, hydraulically released, driveline-mounted, oil-cooled, multi disc | | | | |
| Tires/Wheels (see page 33 for complete tire adjustments) | | | | | |
| | <i>Tread Width</i> | <i>Width Over Tires</i> | | | |
| Michelin 20.5 R 25, 1 Star L-3 | 2050 mm (80.7 in.) | 2657 mm (104.6 in.) | | | |
| Serviceability | | | | | |
| Refill Capacities | | | | | |
| Fuel Tank with Lockable Cap | 299 L (79 gal.) | | | | |
| Diesel Exhaust Fluid (DEF) | 19 L (20 qt.) | | | | |
| Cooling System | 33.8 L (35.7 qt.) | | | | |
| Engine Oil with Vertical Spin-On Filter | 19.5 L (20.6 qt.) | | | | |
| Transmission Reservoir with Vertical Filter | 27 L (28.5 qt.) | | | | |
| Axle Oil | | | | | |
| Front | 22 L (23 qt.) | | | | |
| Rear | 17 L (18 qt.) | | | | |
| Hydraulic Reservoir and Filter | 105.2 L (27.8 gal.) | | | | |
| Park Brake Oil (wet disc) | 0.3 L (10 oz.) | | | | |
| Hydraulic System/Steering | | | | | |
| Pump (loader and steering) | Variable-displacement, axial-piston pump; closed-center, pressure-compensating system | | | | |
| Maximum Rated Flow at 6895 kPa (1,000 psi) and 2,350 rpm | 223 L/m (59 gpm) | | | | |
| System Relief Pressure (loader and steering) | 24 821 kPa (3,675 psi) | | | | |
| Loader Controls | 2-function valve; joystick control or fingertip controls; hydraulic-function enable/disable; optional 3rd- and 4th-function valve with auxilliary lever | | | | |
| Steering (conforms to ISO 5010) | | | | | |
| Type | Power, fully hydraulic | | | | |
| Articulation Angle | 80-deg. arc (40 deg. each direction) | | | | |



| Hydraulic System/Steering <i>(continued)</i> | | 624K-II Z-BAR / HIGH-LIFT / POWERLIFT / TOOL CARRIER | | |
|---|-----------------------|--|--------------|--|
| Turning Radius (measured to centerline of outside tire) | 5.27 m (17 ft. 4 in.) | | | |
| Hydraulic Cycle Times | Z-Bar / High-Lift | Powerlift | Tool Carrier | |
| Raise | 5.9 sec. | 5.9 sec. | 5.6 sec. | |
| Dump | 1.3 sec. | 1.4 sec. | 3.0 sec. | |
| Lower (float down) | 2.7 sec. | 2.8 sec. | 2.7 sec. | |
| Total | 9.9 sec. | 10.1 sec. | 11.3 sec. | |

Dimensions and Specifications with Pin-On Bucket

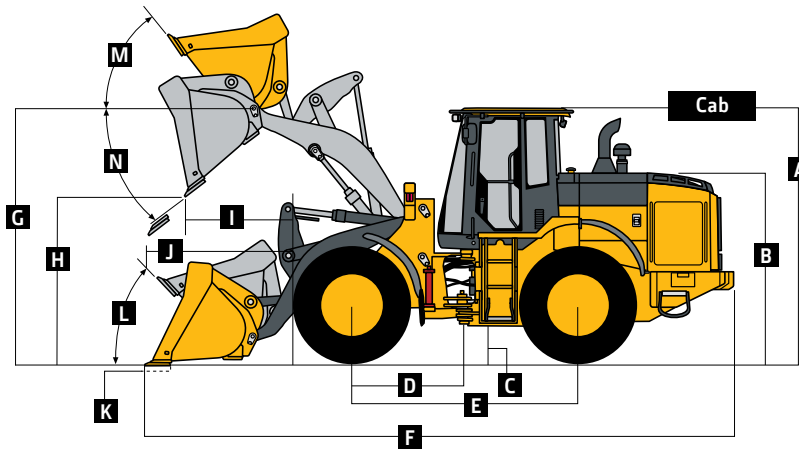

624K-II Z-BAR AND HIGH-LIFT LOADERS WITH PIN-ON BUCKET

| | Z-Bar | High-Lift |
|---|--|----------------------------------|
| Dimensions with Bucket | 2.7-m ³ (3.5 cu. yd.) general-purpose with bolt-on edge | |
| A Height to Top of Cab | 3.32 m (10 ft. 11 in.) | 3.32 m (10 ft. 11 in.) |
| B Hood Height | 2.46 m (8 ft. 1 in.) | 2.46 m (8 ft. 1 in.) |
| C Ground Clearance | 384 mm (15.1 in.) | 384 mm (15.1 in.) |
| D Length from Centerline to Front Axle | 1.52 m (5 ft. 0 in.) | 1.52 m (5 ft. 0 in.) |
| E Wheelbase | 3.09 m (10 ft. 1 in.) | 3.09 m (10 ft. 1 in.) |
| F Overall Length, Bucket on Ground | 7.76 m (25 ft. 5 in.) | 8.17 m (26 ft. 9 in.) |
| G Height to Hinge Pin, Fully Raised | 3.95 m (13 ft. 0 in.) | 4.30 m (14 ft. 2 in.) |
| H Dump Clearance, 45 deg., Full Height | 2.86 m (9 ft. 5 in.) | 3.23 m (10 ft. 7 in.) |
| I Reach, 45-deg. Dump, Full Height | 1.02 m (3 ft. 4 in.) | 1.11 m (3 ft. 8 in.) |
| J Reach, 45-deg. Dump, 2.13-m (7 ft. 0 in.) Clearance | 1.57 m (5 ft. 2 in.) | 1.93 m (6 ft. 4 in.) |
| K Maximum Digging Depth | 95 mm (3.8 in.) | 203 mm (8.0 in.) |
| L Maximum Rollback at Ground Level | 37 deg. | 36 deg. |
| M Maximum Rollback, Boom Fully Raised | 50 deg. | 49 deg. |
| N Maximum Bucket Dump Angle, Fully Raised | 45 deg. | 46 deg. |
| Loader Clearance Circle, Bucket Carry Position | 12.24 m (40 ft. 2 in.) | 12.61 m (41 ft. 4 in.) |
| Specifications with Bucket | | |
| Capacity, Heaped | 2.7 m ³ (3.5 cu. yd.) | 2.7 m ³ (3.5 cu. yd.) |
| Capacity, Struck | 2.3 m ³ (3.0 cu. yd.) | 2.3 m ³ (3.0 cu. yd.) |
| Bucket Weight with Bolt-On Cutting Edge | 1148 kg (2,532 lb.) | 1148 kg (2,532 lb.) |
| Bucket Width | 2.69 m (8 ft. 10 in.) | 2.69 m (8 ft. 10 in.) |
| Breakout Force | 12 821 kg (28,266 lb.) | 11 662 kg (25,709 lb.) |
| Tipping Load, Straight, No Tire Deflection | 13 804 kg (30,433 lb.) | 11 590 kg (25,552 lb.) |
| Tipping Load, Straight, with Tire Deflection | 13 005 kg (28,671 lb.) | 11 007 kg (24,266 lb.) |
| Tipping Load, 40-deg. Full Turn, No Tire Deflection | 12 006 kg (26,469 lb.) | 10 044 kg (22,143 lb.) |
| Tipping Load, 40-deg. Full Turn, with Tire Deflection | 10 956 kg (24,154 lb.) | 9255 kg (20,404 lb.) |
| Rated Operating Load, 50% Full-Turn Tipping Load, No Tire Deflection (conforms to ISO 14397-1)* | 6003 kg (13,234 lb.) | 5022 kg (11,072 lb.) |
| Rated Operating Load, 50% Full-Turn Tipping Load, with Tire Deflection (conforms to ISO 14397-1)* | 5478 kg (12,077 lb.) | 4627 kg (10,201 lb.) |
| Operating Weight | 15 747 kg (34,717 lb.) | 15 948 kg (35,159 lb.) |

Loader operating information is based on machine with identified linkage and standard equipment, PowerTech PVX 6068 (EPA Final Tier 4/EU Stage IV) engine, ROPS cab, rear cast bumper/counterweight, transmission side-frame guards, bottom guards, standard tires, full fuel tank, and 79-kg (175 lb.) operator. This information is affected by changes in tires, ballast, and different attachments.

*Rated operating capacity based on Deere attachments only.

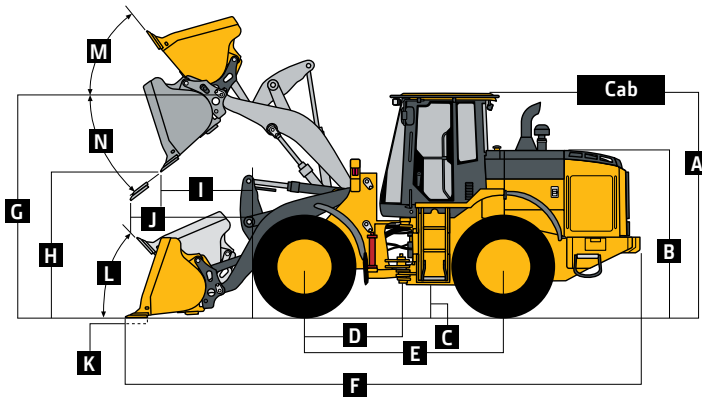

624K-II Z-BAR AND HIGH-LIFT LOADERS WITH QUICK-COUPLER AND HOOK-ON BUCKET

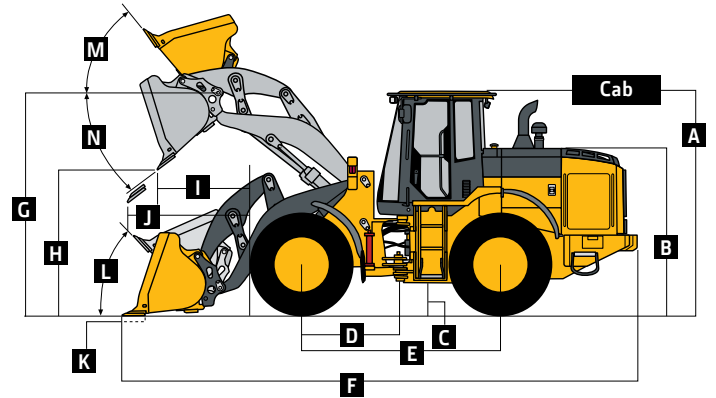

624K-II POWERLEL LOADER WITH QUICK-COUPLER AND HOOK-ON BUCKET

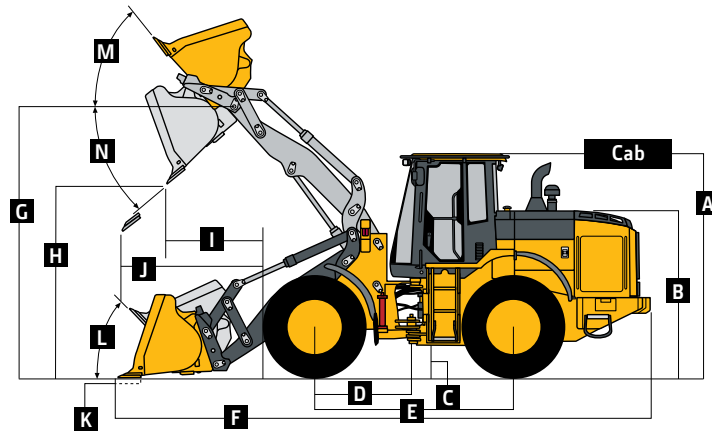

624K-II TOOL CARRIER LOADER WITH QUICK-COUPLER AND HOOK-ON BUCKET

| | Z-Bar | Z-Bar | High-Lift | High-Lift | Powerlel | Powerlel | Tool Carrier | Tool Carrier |
|--|--|---|--|---|--|---|--|---|
| Dimensions with Bucket | 2.7-m ³ (3.5 cu. yd.) general-purpose with bolt-on edge | 4.01-m ³ (5.25 cu. yd.) light-material with bolt-on edge | 2.7-m ³ (3.5 cu. yd.) general-purpose with bolt-on edge | 4.01-m ³ (5.25 cu. yd.) light-material with bolt-on edge | 2.7-m ³ (3.5 cu. yd.) general-purpose with bolt-on edge | 4.01-m ³ (5.25 cu. yd.) light-material with bolt-on edge | 2.7-m ³ (3.5 cu. yd.) general-purpose with bolt-on edge | 4.01-m ³ (5.25 cu. yd.) light-material with bolt-on edge |
| A Height to Top of Cab | 3.32 m (10 ft. 11 in.) | 3.32 m (10 ft. 11 in.) | 3.32 m (10 ft. 11 in.) | 3.32 m (10 ft. 11 in.) | 3.32 m (10 ft. 11 in.) | 3.32 m (10 ft. 11 in.) | 3.32 m (10 ft. 11 in.) | 3.32 m (10 ft. 11 in.) |
| B Hood Height | 2.46 m (8 ft. 1 in.) | 2.46 m (8 ft. 1 in.) | 2.46 m (8 ft. 1 in.) | 2.46 m (8 ft. 1 in.) | 2.46 m (8 ft. 1 in.) | 2.46 m (8 ft. 1 in.) | 2.46 m (8 ft. 1 in.) | 2.46 m (8 ft. 1 in.) |
| C Ground Clearance | 384 mm (15.1 in.) | 384 mm (15.1 in.) | 384 mm (15.1 in.) | 384 mm (15.1 in.) | 384 mm (15.1 in.) | 384 mm (15.1 in.) | 384 mm (15.1 in.) | 384 mm (15.1 in.) |
| D Length from Centerline to Front Axle | 1.52 m (5 ft. 0 in.) | 1.52 m (5 ft. 0 in.) | 1.52 m (5 ft. 0 in.) | 1.52 m (5 ft. 0 in.) | 1.52 m (5 ft. 0 in.) | 1.52 m (5 ft. 0 in.) | 1.52 m (5 ft. 0 in.) | 1.52 m (5 ft. 0 in.) |
| E Wheelbase | 3.09 m (10 ft. 1 in.) | 3.09 m (10 ft. 1 in.) | 3.09 m (10 ft. 1 in.) | 3.09 m (10 ft. 1 in.) | 3.09 m (10 ft. 1 in.) | 3.09 m (10 ft. 1 in.) | 3.09 m (10 ft. 1 in.) | 3.09 m (10 ft. 1 in.) |
| F Overall Length, Bucket on Ground | 7.98 m (26 ft. 2 in.) | 8.09 m (26 ft. 6 in.) | 8.39 m (27 ft. 6 in.) | 8.50 m (27 ft. 11 in.) | 8.13 m (26 ft. 8 in.) | 8.42 m (27 ft. 7.5 in.) | 7.95 m (26 ft. 1 in.) | 8.19 m (26 ft. 10 in.) |
| G Height to Hinge Pin, Fully Raised | 3.96 m (13 ft. 0 in.) | 3.96 m (13 ft. 0 in.) | 4.32 m (14 ft. 2 in.) | 4.32 m (14 ft. 2 in.) | 3.99 m (13 ft. 1 in.) | 3.99 m (13 ft. 1 in.) | 3.99 m (13 ft. 1 in.) | 3.99 m (13 ft. 1 in.) |
| H Dump Clearance, 45 deg., Full Height | 2.69 m (8 ft. 10 in.) | 2.56 m (8 ft. 5 in.) | 3.06 m (10 ft. 1 in.) | 2.90 m (9 ft. 6 in.) | 2.70 m (8 ft. 10 in.) | 2.55 m (8 ft. 4 in.) | 2.81 m (9 ft. 3 in.) | 2.60 m (8 ft. 6 in.) |
| I Reach, 45-deg. Dump, Full Height | 1.11 m (3 ft. 8 in.) | 1.15 m (3 ft. 9 in.) | 1.20 m (3 ft. 11 in.) | 1.23 m (4 ft. 0 in.) | 1.28 m (4 ft. 2 in.) | 1.31 m (4 ft. 4 in.) | 1.45 m (4 ft. 9 in.) | 1.42 m (4 ft. 8 in.) |
| J Reach, 45-deg. Dump, 2.13-m (7 ft. 0 in.) Clearance | 1.56 m (5 ft. 2 in.) | 1.50 m (4 ft. 11 in.) | 1.94 m (6 ft. 4 in.) | 1.90 m (6 ft. 3 in.) | 1.75 m (5 ft. 9 in.) | 1.70 m (5 ft. 7 in.) | 1.85 m (6 ft. 1 in.) | 1.77 m (5 ft. 10 in.) |
| K Maximum Digging Depth | 165 mm (6.5 in.) | 257 mm (10.12 in.) | 262 mm (10.3 in.) | 358 mm (14.0 in.) | 119 mm (4.7 in.) | 228 mm (9.0 in.) | 102 mm (4.0 in.) | 225 mm (8.9 in.) |
| L Maximum Rollback at Ground Level | 39 deg. | 40 deg. | 39 deg. | 41 deg. | 42 deg. | 45 deg. | 49 deg. | 56 deg. |
| M Maximum Rollback, Boom Fully Raised | 55 deg. | 56 deg. | 48 deg. | 50 deg. | 52 deg. | 53 deg. | 64 deg. | 58.5 deg. |
| N Maximum Bucket Dump Angle, Fully Raised | 45 deg. | 49 deg. | 42 deg. | 45 deg. | 46 deg. | 48 deg. | 43 deg. | 48 deg. |
| Loader Clearance Circle, Bucket Carry Position | 12.38 m (40 ft. 7 in.) | 13.00 m (42 ft. 8 in.) | 12.77 m (41 ft. 11 in.) | 13.36 m (43 ft. 10 in.) | 12.60 m (41 ft. 4 in.) | 12.90 m (42 ft. 4 in.) | 12.26 m (40 ft. 3 in.) | 12.55 m (41 ft. 2 in.) |

Dimensions and Specifications with Hi-Vis Coupler and Hook-On Bucket (continued)

624K-II Z-BAR / HIGH-LIFT / POWERLEL / TOOL CARRIER

| Specifications with Bucket | Z-Bar 2.7-m ³ (3.5 cu. yd.) general-purpose with bolt-on edge | Z-Bar 4.01-m ³ (5.25 cu. yd.) light-material with bolt-on edge | High-Lift 2.7-m ³ (3.5 cu. yd.) general-purpose with bolt-on edge | High-Lift 4.01-m ³ (5.25 cu. yd.) light-material with bolt-on edge | Powerlrel 2.7-m ³ (3.5 cu. yd.) general-purpose with bolt-on edge | Powerlrel 4.01-m ³ (5.25 cu. yd.) light-material with bolt-on edge | Tool Carrier 2.7-m ³ (3.5 cu. yd.) general-purpose with bolt-on edge | Tool Carrier 4.01-m ³ (5.25 cu. yd.) light-material with bolt-on edge |
|---|---|--|---|--|---|--|--|---|
| Capacity, Heaped | 2.7 m ³ (3.5 cu. yd.) | 4.0 m ³ (5.25 cu. yd.) | 2.7 m ³ (3.5 cu. yd.) | 4.0 m ³ (5.25 cu. yd.) | 2.7 m ³ (3.5 cu. yd.) | 4.0 m ³ (5.25 cu. yd.) | 2.7 m ³ (3.5 cu. yd.) | 4.0 m ³ (5.25 cu. yd.) |
| Capacity, Struck | 2.3 m ³ (3.0 cu. yd.) | 3.5 m ³ (4.6 cu. yd.) | 2.3 m ³ (3.0 cu. yd.) | 3.5 m ³ (4.6 cu. yd.) | 2.3 m ³ (3.0 cu. yd.) | 3.5 m ³ (4.6 cu. yd.) | 2.3 m ³ (3.0 cu. yd.) | 3.5 m ³ (4.6 cu. yd.) |
| Bucket Weight with Bolt-On Cutting Edge | 1532 kg (3,378 lb.) | 1890 kg (4,167 lb.) | 1532 kg (3,378 lb.) | 1890 kg (4,167 lb.) | 1562 kg (3,444 lb.) | 1913 kg (4,217 lb.) | 1077 kg (2,375 lb.) | 1724 kg (3,801 lb.) |
| Bucket Width | 2.69 m (8 ft. 10 in.) | 3.05 m (10 ft. 0 in.) | 2.69 m (8 ft. 10 in.) | 3.05 m (10 ft. 0 in.) | 2.69 m (8 ft. 10 in.) | 3.05 m (10 ft. 0 in.) | 2.69 m (8 ft. 10 in.) | 3.05 m (10 ft. 0 in.) |
| Breakout Force | 10 983 kg (24,214 lb.) | 9849 kg (21,713 lb.) | 9998 kg (22,042 lb.) | 9035 kg (19,919 lb.) | 10 759 kg (23,719 lb.) | 10 638 kg (23,453 lb.) | 10 978 kg (24,202 lb.) | 9826 kg (21,663 lb.) |
| Tipping Load, Straight, No Tire Deflection | 12 357 kg (27,242 lb.) | 11 924 kg (26,288 lb.) | 10 419 kg (22,969 lb.) | 10 001 kg (22,048 lb.) | 10 803 kg (23,816 lb.) | 10 299 kg (22,705 lb.) | 11 837 kg (26,097 lb.) | 11 337 kg (24,994 lb.) |
| Tipping Load, Straight, with Tire Deflection | 11 661 kg (25,708 lb.) | 11 199 kg (24,689 lb.) | 9900 kg (21,826 lb.) | 9540 kg (21,032 lb.) | 10 251 kg (22,600 lb.) | 9729 kg (21,449 lb.) | 11 169 kg (24,623 lb.) | 10 659 kg (23,499 lb.) |
| Tipping Load, 40-deg. Full Turn, No Tire Deflection | 10 694 kg (23,577 lb.) | 10 278 kg (22,659 lb.) | 8975 kg (19,786 lb.) | 8573 kg (18,900 lb.) | 9312 kg (20,530 lb.) | 8835 kg (19,478 lb.) | 10 253 kg (22,605 lb.) | 9774 kg (21,548 lb.) |
| Tipping Load, 40-deg. Full Turn, with Tire Deflection | 9768 kg (21,535 lb.) | 9318 kg (20,542 lb.) | 8268 kg (18,228 lb.) | 7827 kg (17,255 lb.) | 8547 kg (18,843 lb.) | 8064 kg (17,778 lb.) | 9354 kg (20,622 lb.) | 8862 kg (19,537 lb.) |
| Rated Operating Load, 50% Full-Turn Tipping Load, No Tire Deflection (conforms to ISO 14397-1)* | 5347 kg (11,788 lb.) | 5139 kg (11,329 lb.) | 4487 kg (9,893 lb.) | 4286 kg (9,449 lb.) | 4656 kg (10,265 lb.) | 4417 kg (9,738 lb.) | 5127 kg (11,302 lb.) | 4887 kg (10,774 lb.) |
| Rated Operating Load, 50% Full-Turn Tipping Load, with Tire Deflection (conforms to ISO 14397-1)* | 4884 kg (10,767 lb.) | 4659 kg (10,271 lb.) | 4134 kg (9,114 lb.) | 3913 kg (8,627 lb.) | 4273 kg (9,420 lb.) | 4032 kg (8,889 lb.) | 4677 kg (10,311 lb.) | 4431 kg (9,769 lb.) |
| Operating Weight | 16 152 kg (35,608 lb.) | 16 477 kg (36,325 lb.) | 16 352 kg (36,050 lb.) | 16,678 kg (36,769 lb.) | 17 167 kg (37,847 lb.) | 17 472 kg (38,519 lb.) | 16 166 kg (35,640 lb.) | 16 482 kg (36,336 lb.) |

Loader operating information is based on machine with identified linkage and standard equipment, PowerTech PVX 6068 (EPA Final Tier 4/EU Stage IV) engine, ROPS cab, rear cast bumper/counterweight, transmission side-frame guards, bottom guards, standard tires, full fuel tank, and 79-kg (175 lb.) operator. This information is affected by changes in tires, ballast, and different attachments.

*Rated operating capacity based on Deere attachments only.

Bucket Selection Guides

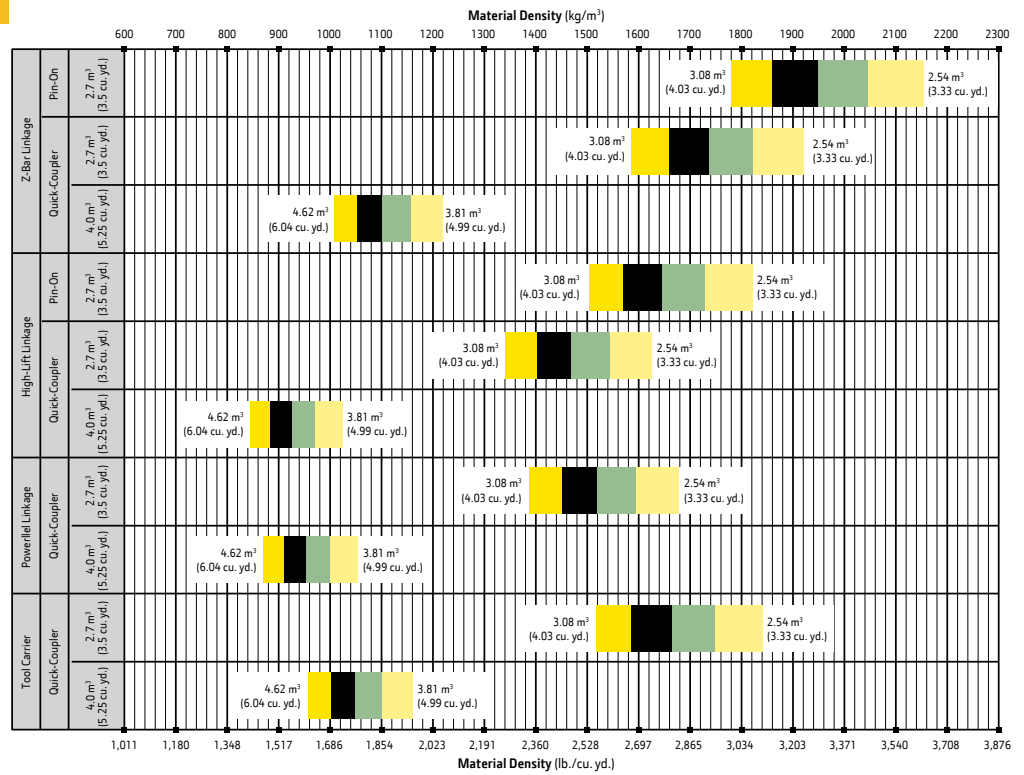

| LOOSE MATERIALS | kg/m ³ | lb./cu. yd. | LOOSE MATERIALS | kg/m ³ | lb./cu. yd. |
|----------------------------------|-------------------|-------------|---|-------------------|-------------|
| Chips, pulpwood | 288 | 486 | Limestone, coarse, sized | 1570 | 2,646 |
| Cinders (coal, ashes, clinkers) | 673 | 1,134 | Limestone, mixed sizes | 1682 | 2,835 |
| Clay and gravel, dry | 1602 | 2,700 | Limestone, pulverized or crushed | 1362 | 2,295 |
| Clay, compact, solid | 1746 | 2,943 | Sand, damp | 2083 | 3,510 |
| Clay, dry in lump loose | 1009 | 1,701 | Sand, dry | 1762 | 2,970 |
| Clay, excavated in water | 1282 | 2,160 | Sand, voids, full of water | 2083 | 3,510 |
| Coal, anthracite, broken, loose | 865 | 1,458 | Sandstone, quarried | 1314 | 2,214 |
| Coal, bituminous, moderately wet | 801 | 1,350 | Shale, broken crushed | 1362 | 2,295 |
| Earth, common loam, dry | 1218 | 2,052 | Slag, furnace granulated | 1955 | 3,294 |
| Earth, mud, packed | 1843 | 3,105 | Stone or gravel, 37.5 to 87.5-mm (1.5 to 3.5") size | 1442 | 2,430 |
| Granite, broken | 1538 | 2,592 | Stone or gravel, 18.75-mm (3/4") size | 1602 | 2,700 |
| Gypsum | 2275 | 3,834 | | | |

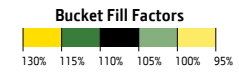

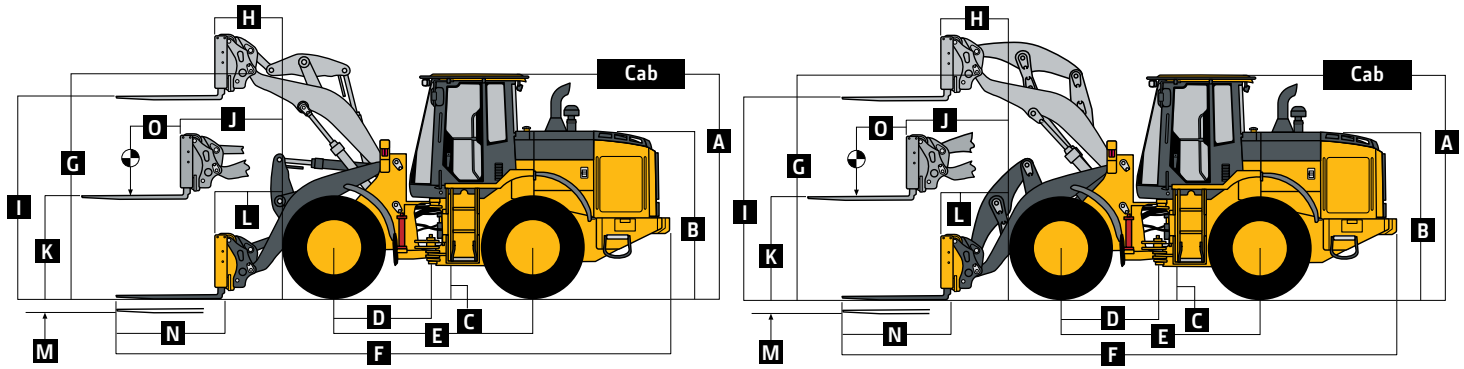

624K-II Z-BAR AND HIGH-LIFT LOADERS WITH
QUICK-COUPLER AND HOOK-ON CONSTRUCTION FORKS

624K-II POWERLLEL LOADER WITH
QUICK-COUPLER AND HOOK-ON CONSTRUCTION FORKS

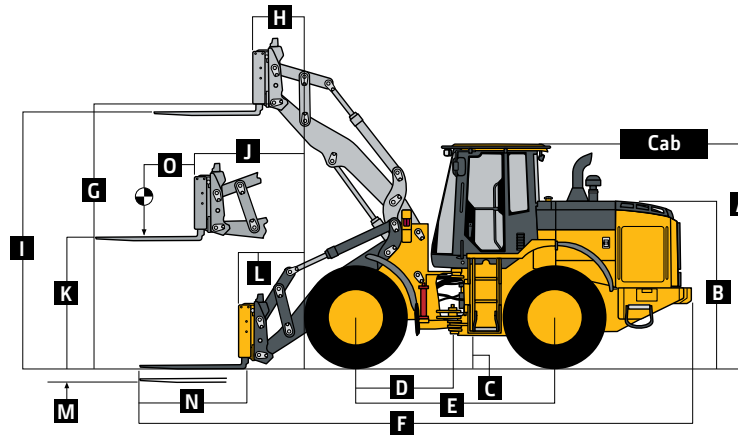

624K-II TOOL CARRIER LOADER WITH QUICK-COUPLER AND HOOK-ON CONSTRUCTION FORKS

| | Z-Bar | Z-Bar | High-Lift | High-Lift | Powerllep | Powerllep | Tool Carrier | Tool Carrier |
|--|--------------------------------|--------------------------------|--------------------------------|--------------------------------|--------------------------------|--------------------------------|--------------------------------|--------------------------------|
| Dimensions with Forks | 1.22-m (48 in.) tine length | 1.52-m (60 in.) tine length | 1.22-m (48 in.) tine length | 1.52-m (60 in.) tine length | 1.22-m (48 in.) tine length | 1.52-m (60 in.) tine length | 1.22-m (48 in.) tine length | 1.52-m (60 in.) tine length |
| A Height to Top of Cab | 3.32 m (10 ft. 11 in.) | | 3.32 m (10 ft. 11 in.) | | 3.32 m (10 ft. 11 in.) | | 3.32 m (10 ft. 11 in.) | |
| B Hood Height | 2.46 m (8 ft. 1 in.) | | 2.46 m (8 ft. 1 in.) | | 2.46 m (8 ft. 1 in.) | | 2.46 m (8 ft. 1 in.) | |
| C Ground Clearance | 384 mm (15.1 in.) | | 384 mm (15.1 in.) | | 384 mm (15.1 in.) | | 384 mm (15.1 in.) | |
| D Length from Centerline to Front Axle | 1.52 m (5 ft. 0 in.) | | 1.52 m (5 ft. 0 in.) | | 1.52 m (5 ft. 0 in.) | | 1.52 m (5 ft. 0 in.) | |
| E Wheelbase | 3.09 m (10 ft. 1 in.) | | 3.09 m (10 ft. 1 in.) | | 3.09 m (10 ft. 1 in.) | | 3.09 m (10 ft. 1 in.) | |
| F Overall Length, Forks on Ground | 8.18 m (26 ft. 10 in.) | 8.48 m (27 ft. 10 in.) | 8.60 m (28 ft. 2 in.) | 8.89 m (29 ft. 2 in.) | 8.30 m (27 ft. 3 in.) | 8.60 m (28 ft. 3 in.) | 8.02 m (26 ft. 4 in.) | 8.33 m (27 ft. 4 in.) |
| G Height to Hinge Pin, Fully Raised | 3.96 m (13 ft. 0 in.) | | 4.32 m (14 ft. 2 in.) | | 3.99 m (13 ft. 1 in.) | | 3.99 m (13 ft. 1 in.) | |
| H Reach, Fully Raised | 0.75 m (29.5 in.) | | 0.84 m (33 in.) | | 0.92 m (36 in.) | | 0.89 m (35 in.) | |
| I Fork Height, Fully Raised | 3.73 m (12 ft. 3 in.) | | 4.09 m (13 ft. 5 in.) | | 3.76 m (12 ft. 4 in.) | | 3.91 m (12 ft. 10 in.) | |
| J Maximum Reach, Fork Level | 1.58 m (5 ft. 2 in.) | | 1.92 m (6 ft. 4 in.) | | 1.77 m (5 ft. 10 in.) | | 1.65 m (5 ft. 5 in.) | |
| K Fork Height, Maximum Reach | 1.77 m (5 ft. 10 in.) | | 1.77 m (5 ft. 10 in.) | | 1.84 m (6 ft. 1 in.) | | 1.99 m (6 ft. 7 in.) | |
| L Reach, Ground Level | 0.96 m (3 ft. 2 in.) | | 1.40 m (4 ft. 7 in.) | | 1.11 m (3 ft. 8 in.) | | 0.88 m (35 in.) | |
| M Depth Below Ground | 23 mm (0.9 in.) | | 123 mm (4.8 in.) | | 19 mm (0.8 in.) | | 0 mm (0 in.) | |
| N Tine Length | 1.22 m (48 in.) | 1.52 m (60 in.) | 1.22 m (48 in.) | 1.52 m (60 in.) | 1.22 m (48 in.) | 1.52 m (60 in.) | 1.22 m (48 in.) | 1.52 m (60 in.) |
| O Load Position, 50% Tine Length | 0.61 m (24 in.) | 0.76 m (30 in.) | 0.61 m (24 in.) | 0.76 m (30 in.) | 0.61 m (24 in.) | 0.76 m (30 in.) | 0.61 m (24 in.) | 0.76 m (30 in.) |

Dimensions and Specifications with Hi-Vis Coupler and Construction Forks (continued)

624K-II Z-BAR / HIGH-LIFT / POWERLLEL / TOOL CARRIER

| Specifications with Forks | Z-Bar 1.22-m (48 in.) tine length | Z-Bar 1.52-m (60 in.) tine length | High-Lift 1.22-m (48 in.) tine length | High-Lift 1.52-m (60 in.) tine length | Powerllel 1.22-m (48 in.) tine length | Powerllel 1.52-m (60 in.) tine length | Tool Carrier 1.22-m (48 in.) tine length | Tool Carrier 1.52-m (60 in.) tine length |
|--|---|---|---|---|---|---|--|--|
| Tipping Load, Straight, No Tire Deflection | 9706 kg (21,398 lb.) | 9185 kg (20,249 lb.) | 8642 kg (19,052 lb.) | 8215 kg (18,111 lb.) | 9054 kg (19,961 lb.) | 8595 kg (18,949 lb.) | 9369 kg (20,655 lb.) | 8889 kg (19,597 lb.) |
| Tipping Load, Straight, with Tire Deflection | 9420 kg (20,767 lb.) | 8919 kg (19,663 lb.) | 8397 kg (18,512 lb.) | 7986 kg (17,606 lb.) | 8778 kg (19,532 lb.) | 8340 kg (18,387 lb.) | 9102 kg (20,066 lb.) | 8637 kg (19,041 lb.) |
| Tipping Load, 40-deg. Full Turn, No Tire Deflection | 8445 kg (18,618 lb.) | 7985 kg (17,604 lb.) | 7494 kg (16,521 lb.) | 7116 kg (15,688 lb.) | 7854 kg (17,315 lb.) | 7446 kg (16,416 lb.) | 8157 kg (17,983 lb.) | 7731 kg (17,044 lb.) |
| Tipping Load, 40-deg. Full Turn, with Tire Deflection | 8052 kg (17,752 lb.) | 7623 kg (16,806 lb.) | 7155 kg (15,774 lb.) | 6801 kg (14,994 lb.) | 7473 kg (16,745 lb.) | 7098 kg (15,648 lb.) | 7776 kg (17,143 lb.) | 7383 kg (16,277 lb.) |
| Rated Operating Load, 50% Full-Turn Tipping Load, with Tire Deflection (conforms to ISO 14397-1 and SAE J1197)* | 4026 kg (8,876 lb.) | 3812 kg (8,404 lb.) | 3578 kg (7,888 lb.) | 3401 kg (7,498 lb.) | 3737 kg (8,239 lb.) | 3549 kg (7,824 lb.) | 3888 kg (8,572 lb.) | 3692 kg (8,139 lb.) |
| Rated Operating Load, Rough Terrain, 60% Full-Turn Tipping Load, with Tire Deflection (conforms to EN474-3)* | 4831 kg (10,650 lb.) | 4574 kg (10,084 lb.) | 4293 kg (9,464 lb.) | 4081 kg (8,997 lb.) | 4484 kg (9,885 lb.) | 4259 kg (9,389 lb.) | 4666 kg (10,287 lb.) | 4430 kg (9,767 lb.) |
| Rated Operating Load, Firm and Level Ground, 80% Full-Turn Tipping Load, with Tire Deflection (conforms to EN474-3)* | 6442 kg (14,202 lb.) | 6098 kg (13,444 lb.) | 5724 kg (12,619 lb.) | 5441 kg (11,995 lb.) | 5978 kg (13,179 lb.) | 5678 kg (12,518 lb.) | 6221 kg (13,715 lb.) | 5906 kg (13,020 lb.) |
| Operating Weight | 15 730 kg (34,679 lb.) | 15 773 kg (34,773 lb.) | 15 931 kg (35,122 lb.) | 15 971 kg (35,210 lb.) | 16 702 kg (36,822 lb.) | 16 745 kg (36,916 lb.) | 15 703 kg (34,619 lb.) | 15 746 kg (34,714 lb.) |

Loader operating information is based on machine with identified linkage and standard equipment, PowerTech PVX 6068 (EPA Final Tier 4/EU Stage IV) engine, ROPS cab, rear cast bumper/counterweight, transmission side-frame guards, bottom guards, standard tires, full fuel tank, and 79-kg (175 lb.) operator. This information is affected by changes in tires, ballast, and different attachments.

*Rated operating capacity based on Deere attachments only.

Adjustments to Operating Weights and Tipping Loads with Buckets

Adjustments to operating weights, tipping loads, and tires are based on Z-Bar machine with pin-on 2.7-m³ (3.5 cu. yd.) general-purpose bucket with bolt-on cutting edge, ROPS cab, rear cast bumper/counterweight, transmission side-frame guards, bottom guards, standard tires, full fuel tank, and 79-kg (175 lb.) operator*

| Add (+) or deduct (-) kg (lb.) as indicated for loaders with 3-piece rims | Operating Weight | Tipping Load, Straight | Tipping Load, 40-deg. Full Turn SAE | Tread Width | Width Over Tires | Vertical Height |
|---|-----------------------|------------------------|-------------------------------------|--------------|-------------------|--------------------|
| John Deere PowerTech PVX 6068 | 0 kg (0 lb.) | 0 kg (0 lb.) | 0 kg (0 lb.) | N/A | N/A | N/A |
| John Deere PowerTech Plus 6068H | -130 kg (-287 lb.) | +38 kg (+84 lb.) | 0 kg (0 lb.) | N/A | N/A | N/A |
| John Deere PowerTech 6068H | -146 kg (-322 lb.) | -7 kg (-15 lb.) | -45 kg (-101 lb.) | N/A | N/A | N/A |
| Powerllel Linkage, 2.7-m ³ (3.5 cu. yd.) Hook-On | 0 kg (0 lb.) | 0 kg (0 lb.) | 0 kg (0 lb.) | 0 mm (0 in.) | 0 mm (0 in.) | 0 mm (0 in.) |
| Tool-Carrier Linkage, 2.7-m ³ (3.5 cu. yd.) Hook-On | 0 kg (0 lb.) | 0 kg (0 lb.) | 0 kg (0 lb.) | 0 mm (0 in.) | 0 mm (0 in.) | 0 mm (0 in.) |
| Michelin 20.5 R 25, 1 Star L-3 | 0 kg (0 lb.) | 0 kg (0 lb.) | 0 kg (0 lb.) | 0 mm (0 in.) | 0 mm (0 in.) | 0 mm (0 in.) |
| Bridgestone 20.5 R 25, 1 Star L-3 | +44 kg (+97 lb.) | +33 kg (+73 lb.) | +29 kg (+64 lb.) | 0 mm (0 in.) | -16 mm (-0.6 in.) | 0 mm (0 in.) |
| Titan 20.5 R 25, 1 Star L-3 | -4 kg (-9 lb.) | -3 kg (-7 lb.) | -3 kg (-7 lb.) | 0 mm (0 in.) | -16 mm (-0.6 in.) | 0 mm (0 in.) |
| Michelin 20.5 R 25, 1 Star L-2 | -172 kg (-379 lb.) | -129 kg (-285 lb.) | -114 kg (-251 lb.) | 0 mm (0 in.) | -16 mm (-0.6 in.) | -3 mm (-0.1 in.) |
| Bridgestone 20.5 R 25, 1 Star L-2 | -80 kg (-176 lb.) | -60 kg (-132 lb.) | -53 kg (-117 lb.) | 0 mm (0 in.) | -16 mm (-0.6 in.) | -3 mm (-0.1 in.) |
| Titan 20.5 R 25, 1 Star L-2 | -128 kg (-282 lb.) | -96 kg (-212 lb.) | -85 kg (-187 lb.) | 0 mm (0 in.) | -16 mm (-0.6 in.) | -3 mm (-0.1 in.) |
| Firestone 20.5-25, 16 PR L-3 | -252 kg (-556 lb.) | -189 kg (-417 lb.) | -167 kg (-367 lb.) | 0 mm (0 in.) | -12 mm (-0.5 in.) | +13 mm (+0.5 in.) |
| Titan 20.5-25, 16 PR L-2 | -260 kg (-573 lb.) | +195 kg (+430 lb.) | -172 kg (-379 lb.) | 0 mm (0 in.) | -12 mm (-0.5 in.) | +6 mm (+0.2 in.) |
| Firestone 20.5-25, 16 PR L-2 | -280 kg (-617 lb.) | -210 kg (-464 lb.) | -185 kg (-408 lb.) | 0 mm (0 in.) | -12 mm (-0.5 in.) | +6 mm (+0.2 in.) |
| Michelin 600/65 R 25, 1 Star L-3T [§] | +4 kg (+9 lb.) | +3 kg (+7 lb.) | +3 kg (+6 lb.) | 0 mm (0 in.) | +83 mm (+3.3 in.) | -24 mm (-0.9 in.) |
| 20.5R25 L2 Sno-Plus Michelin | -88 kg (-194 lb.) | -66 kg (-145 lb.) | -58 kg (-128 lb.) | 0 mm (0 in.) | +7 mm (+0.3 in.) | -28 mm (-1.1 in.) |
| 620/75R26 MegaXbib [¶] | -216 kg (-476 lb.) | -162 kg (-357 lb.) | -143 kg (-315 lb.) | 0 mm (0 in.) | +61 mm (+2.4 in.) | +27 mm (+1.06 in.) |
| CaCl ₂ in 20.5-25, L-3 Rear Tires | +1166 kg (+2,571 lb.) | +1432 kg (+3,157 lb.) | +1305 kg (+2,878 lb.) | N/A | N/A | N/A |

*May change based on vehicle configuration, weight, or tire-pressure adjustments.

[§]CaCl₂ not recommended.

[¶]Equipped with 1-piece rims.

[¶]Requires 8-deg. rear axle stops.

Additional equipment

Key: ● Standard ▲ Optional or special See your John Deere dealer for further information.

| 524 | 544 | 624 | Engine |
|---------------------------|-----|-----|---|
| ● | ● | ● | Wet-sleeve cylinder liners |
| ● | ● | ● | Automatic glow plugs for cold start |
| ● | ● | ● | Programmable auto-idle and auto shutdown |
| ● | ● | ● | Selected idle adjustment from 900–1,250 rpm |
| ● | ● | ● | Starter protection |
| ● | ● | ● | Automatic engine cool-down timer |
| ● | ● | ● | Automatic derating for exceeded system temperatures |
| ● | ● | ● | Serpentine drive belt for automatic tensioner |
| ● | ● | ● | Electrical fuel-priming pump |
| ● | ● | ● | Dual-stage fuel filter and water separator |
| ● | ● | ● | 500-hour vertical spin-on oil filter |
| ▲ | ▲ | ▲ | Engine-compartment light |
| ▲ | ▲ | ▲ | Chrome exhaust stack |
| ▲ | ▲ | ▲ | Engine-block heater (recommended for cold starts below –23 deg. C [–10 deg. F]) |
| ▲ | ▲ | ▲ | Centrifugal engine air pre-cleaner |
| Powertrain | | | |
| ● | ● | ● | Programmable maximum high gear |
| ● | ● | ● | Clutch calibration engaged from monitor |
| ● | ● | ● | 2,000-hour vertical spin-on transmission filter |
| ● | ● | ● | Transmission fill tube and sight gauge |
| ● | ● | ● | Transmission diagnostic ports |
| ● | ● | ● | 5-speed transmission with lockup torque converter |
| ● | ▲ | ▲ | 5-speed transmission with non-lockup torque converter |
| ● | ● | ● | Front locking differential |
| ▲ | ▲ | ▲ | Rear locking differential |
| ● | ● | ● | Brake retractors and adjusters |
| ▲ | ▲ | ▲ | Automatic differential lock |
| ● | ● | ● | Axle oil temperature sensing |
| ▲ | ▲ | ▲ | Wheel-spin control |
| Quad-Cool™ Cooling System | | | |
| ● | ● | ● | Heavy-duty, trash-resistant radiator and high-ambient cooling package |
| ● | ● | ● | 2-side access to all coolers |
| ● | ● | ● | Isolated from engine compartment |
| ● | ● | ● | Engine radiator |
| ● | ● | ● | Integral engine oil cooler |
| ● | ● | ● | Hydraulic oil cooler (oil to air) |
| ● | ● | ● | Transmission oil cooler (oil to air) |
| ● | ● | ● | Charge air cooler (air to air) |
| ● | ● | ● | Fuel cooler |
| ● | ● | ● | Coolant recovery tank |
| ● | ● | ● | Antifreeze, –37 deg. C (–34 deg. F) |
| ● | ● | ● | Cool-on-demand, hydraulically driven, swing-out fan |
| ● | ● | ● | Enclosed fan safety guard |
| ▲ | ▲ | ▲ | Automatic reversing fan drive |
| ▲ | ▲ | ● | Axle and service-brake coolers |

| 524 | 544 | 624 | Hydraulics |
|------------------|-----|-----|--|
| ● | ● | ● | Automatic return-to-dig bucket positioner |
| ● | ● | ● | In-cab adjustable automatic return-to-dig bucket positioner (Powerllec™ only) |
| ● | ● | ● | In-cab adjustable automatic boom-height kickout/return to carry |
| ● | ● | ● | Reservoir with sight gauge and fill strainer |
| ● | ● | ● | Hydraulic diagnostic ports |
| ● | ● | ● | 4,000-hour in-tank filter |
| ● | ● | ● | 2 function — joystick with F-N-R |
| ▲ | ▲ | ▲ | 2 function — joystick with steering column F-N-R |
| ▲ | ▲ | ▲ | 2 function — 2-lever fingertip controls and steering column F-N-R |
| ▲ | ▲ | ▲ | 3 function — joystick with F-N-R and 3rd-function auxiliary lever |
| ▲ | ▲ | ▲ | 3 function — joystick with steering column F-N-R and 3rd-function auxiliary lever |
| ▲ | ▲ | ▲ | 3 function — 3-lever fingertip controls and steering column F-N-R |
| ▲ | ▲ | ▲ | 4 function — 4-lever fingertip controls and steering column F-N-R |
| ▲ | ▲ | ▲ | Ride control, automatic with monitor-adjustable speed settings |
| ▲ | ▲ | ▲ | Hydraulic control system for quick-coupler locking pins |
| ▲ | ▲ | ▲ | Hydrau™ XR cold-temperature hydraulic fluid recommended below –25 deg. C. (–13 deg. F) |
| Steering Systems | | | |
| ● | ● | ● | Conventional steering wheel with spinner knob |
| ▲ | ▲ | ▲ | Secondary steering |
| Electrical | | | |
| ● | ● | ● | Solid-state electrical power-distribution system |
| ● | ● | ● | Lockable master electrical-disconnect switch |
| ● | ● | ● | Battery-terminal safety covers |
| ● | ● | ● | By-pass start safety cover at starter |
| ● | ● | ● | Remote jump-start access in battery box |
| ● | ● | ● | Pre-wired for beacon/strobe light |
| ● | ● | ● | Lights: Halogen driving lights with guards (2) / Front (4), rear cab (2), and rear grille (2) work lights / Incandescent front turn signals and flashers / LED stop and taillights |
| ▲ | ▲ | ▲ | Heavy-duty front LED turn signal and marker lights |
| ▲ | ▲ | ▲ | Premium LED light package (all exterior lights are heavy-duty LED) |
| ● | ● | ● | Programmable courtesy lights |
| ● | ● | ● | Horn, electric |
| ● | ● | ● | Reverse warning alarm |
| ● | ● | ● | Multi-function/multi-language LCD color monitor includes: Digital instruments — Analog display (hydraulic oil temperature, engine coolant temperature, transmission oil temperature, and engine oil pressure) / Digital display (engine rpm, transmission gear/direction indicator, hour meter, fuel level, diesel exhaust fluid (DEF) level, speedometer, odometer, and average fuel consumption) |
| ● | ● | ● | Integrated cycle counter with 5 categories |
| ● | ● | ● | Indicator lights: Standard and selected options / Amber caution and red stop |
| ● | ● | ● | Operator-warning messages |
| ● | ● | ● | Built-in diagnostics: Diagnostic-code details / Sensor values / Calibrations / Individual circuit tester |

Net engine power is with standard equipment including air cleaner, exhaust system, alternator, and cooling fan at test conditions per ISO 9249. No derating is required up to 3050-m (10,000 ft.) altitude. Specifications and design subject to change without notice. Specifications with the exception of bucket capacity are in accordance with all applicable ISO standards. Except where otherwise noted, these specifications are based on units with applicable linkage and standard equipment, ROPS cab, rear cast bumper/counterweight, transmission side-frame guards, bottom guards, standard tires, full fuel tank, and 79-kg (175 lb.) operator.

Additional equipment *(continued)*

Key: ● Standard ▲ Optional or special See your John Deere dealer for further information.

| 524 | 544 | 624 | Electrical <i>(continued)</i> |
|---------------------------|-----|-----|--|
| ▲ | ▲ | ▲ | Electrical corrosion-prevention package |
| ▲ | ▲ | ▲ | AM/FM/Weather-Band (WB) radio with remote auxiliary port |
| ▲ | ▲ | ▲ | Premium AM/FM/WB/XM Satellite Radio™ ready radio with Bluetooth®, remote auxiliary port, and remote USB port |
| ● | ● | ● | 24- to 12-volt, 8-amp converter and power port |
| ▲ | ▲ | ▲ | 24- to 12-volt, 15- or 30-amp converter and power port |
| Operator's Station | | | |
| ● | ● | | Canopy (ROPS/FOPS Level 1, isolation mounted) |
| ▲ | ▲ | | Canopy rear window |
| ▲ | ▲ | ▲ | Quiet Cab with heater (ROPS/FOPS Level 1, isolation mounted) |
| ▲ | ▲ | ● | Quiet Cab with air conditioning/heater (ROPS/FOPS Level 1, isolation mounted) |
| ● | ● | ● | Keyless start with multiple security modes |
| ● | ● | ● | Sealed-switch module with function indicators |
| ● | ● | ● | Seat with backrest extension, deep foam, vinyl cover, and adjustable air suspension |
| ▲ | ▲ | ▲ | Seat with backrest extension, deep foam, fabric cover, and adjustable air suspension |
| ▲ | ▲ | ▲ | Premium seat with high-wide back and headrest extension, heated, leather/fabric cover, and adjustable air suspension |
| ● | ● | ● | Hydraulic controls integrated to seat |
| ● | ● | ● | High-visibility, bright-orange seat belt, 76 mm (3 in.), with retractor |
| ● | ● | ● | Cup holders (2) |
| ● | ● | ● | Lunch-box/cooler holder |
| ▲ | ▲ | ● | Dome and reading light (included with Quiet Cab) |
| ● | ● | ● | Rubber floor mat |
| ● | ● | ● | Tilt steering column |
| ● | ● | ● | Operator's manual storage compartment |
| ● | ● | ● | Outside (2) and inside (1) rearview mirrors |
| ▲ | ▲ | ▲ | Large heated outside mirrors |
| ● | ● | ● | Left-side operator-station access |
| ● | ● | ● | Slip-resistant steps and ergonomic handholds |
| ▲ | ▲ | ● | Sun visor (included with Quiet Cab) |
| ▲ | ▲ | ● | Radio ready (Quiet Cab only) |
| ▲ | ▲ | ● | Front and rear intermittent windshield wipers and washers (included with Quiet Cab) |
| ▲ | ▲ | ▲ | Powered cab air pre-cleaner |
| ▲ | ▲ | ▲ | Beacon bracket (single or dual available) |
| ▲ | ▲ | ▲ | Rearview camera |
| ▲ | ▲ | ▲ | Rear camera and radar object-detection system |
| ● | ● | ● | LOADRITE™ L2180™ Payload Scale Ready |
| ▲ | ▲ | ▲ | LOADRITE L2180 Payload Scale |
| ▲ | ▲ | ▲ | Embedded payload scale |
| ▲ | ▲ | ▲ | Fire extinguisher |
| Loader Linkage | | | |
| ● | ● | ● | Z-Bar loader linkage |
| ▲ | ▲ | ▲ | High-Lift Z-Bar loader linkage |
| | ▲ | ▲ | Powerlift linkage for visibility and parallel-lift |
| | ▲ | ▲ | Tool-carrier linkage for parallel-lift |

| 524 | 544 | 624 | Buckets and Attachments |
|------------------------|-----|-----|--|
| ▲ | ▲ | ▲ | Full line of Deere pin-on buckets |
| ▲ | ▲ | ▲ | Worksite Pro™ hydraulic coupler which accepts JRB-pattern attachments |
| ▲ | ▲ | ▲ | Hi-Vis hydraulic coupler which accepts Euro-pattern attachments (Volvo) |
| ▲ | ▲ | ▲ | Full line of Deere hook-on buckets and forks |
| ▲ | ▲ | ▲ | Bolt-on fork frame guard |
| Overall Vehicle | | | |
| ● | ● | ● | JDLINK™ Ultimate wireless communication system (available in specific countries; see your dealer for details) |
| ● | ● | ● | NeverGrease™ rear-axle oscillation |
| ● | ● | ● | NeverGrease steering-cylinder joints |
| ● | ● | ● | Front and rear tie-downs |
| ● | ● | ● | Rear cast bumper/counterweight with rear hitch and locking pin |
| ● | ● | ● | Articulation locking bar |
| ● | ● | ● | Loader boom service locking bar |
| ● | ● | ● | 40-deg. steering articulation to each side with rubber-cushion stops on frame |
| ● | ● | ● | Vandal protection with lockable engine enclosures, right counterweight storage, and filler access for radiator/fuel/DEF/hydraulic transmission |
| ● | ● | ● | Left-side service steps and handholds |
| ▲ | ▲ | ▲ | Right-side service steps and handrails |
| ▲ | ▲ | ▲ | Left-side close-mounted steps |
| ● | ● | ● | Storage compartment |
| ● | ● | ● | Fuel-tank fill strainer |
| ● | ● | ● | Heavy-duty fuel-tank guard |
| ● | ● | ● | DEF and ground-level fueling |
| ● | ● | ● | Same-side ground-level daily servicing |
| ● | ● | ● | 20.5R25 tires on 3-piece rims |
| | | ▲ | Waste handler (Z-Bar and High-Lift) |
| ● | ● | ● | Level 1 sound package |
| ▲ | ▲ | ▲ | Level 2 sound package |
| ▲ | ▲ | ▲ | Environmental drains and sample ports for engine, transmission, hydraulic oils, and engine coolant |
| | | ▲ | Quick fluid service (engine, transmission, hydraulic oils, and engine coolant) |
| ● | ● | ● | Fenders, front |
| ▲ | ▲ | ▲ | Fenders, full-coverage, front |
| ▲ | ▲ | ▲ | Fenders, full-coverage, front and rear |
| ▲ | ▲ | ▲ | Less wheels and tires with 8-deg. axle stops |
| ▲ | ▲ | ▲ | Rims less tires |
| ▲ | ▲ | ▲ | Transmission side-frame guards |
| ▲ | ▲ | ▲ | Bottom guards |
| ▲ | ▲ | ▲ | Lift eyes |
| ▲ | ▲ | ▲ | License-plate bracket and light |
| | | ▲ | Special guarding for waste applications |

Net engine power is with standard equipment including air cleaner, exhaust system, alternator, and cooling fan at test conditions per ISO 9249. No derating is required up to 3050-m (10,000 ft.) altitude. Specifications and design subject to change without notice. Specifications with the exception of bucket capacity are in accordance with all applicable ISO standards. Except where otherwise noted, these specifications are based on units with applicable linkage and standard equipment, ROPS cab, rear cast bumper/counterweight, transmission side-frame guards, bottom guards, standard tires, full fuel tank, and 79-kg (175 lb.) operator.



JOHN DEERE

