



JOHN DEERE

125-180 NET HORSEPOWER

J

LOADERS

444J | 544J | 624J



**Z-BAR
LINKAGE**

Courtesy of MachineMarket



444J

125 hp
2.5-cu.-yd. bucket
18,340-lb. tipping load, straight
15,639-lb. tipping load,
40-degree full turn
18,104-lb. breakout
22,645-lb. operating weight

Take productivity to a higher level.

Whether you're shuttling sand, stockpiling silage, placing pallets, or loading out trucks — the J-Series Loaders will put you at the top of your game. Each comes loaded with production boosting advantages such as a state-of-the-art multifunction monitor with advanced

diagnostics, durable solid-state electrical distribution center, convenient sealed switch module, and an innovative Quad-Cool™ system that keeps everything running cool. That's just for starters. Read on to learn all the ways the J-Series Loaders will help maximize your efforts.



544J

160 hp
3.0-cu.-yd. bucket
22,801-lb. tipping load, straight
18,752-lb. tipping load,
40-degree full turn
22,672-lb. breakout
27,489-lb. operating weight

624J

180 hp
3.5-cu.-yd. bucket
25,639-lb. tipping load, straight
21,854-lb. tipping load,
40-degree full turn
28,483-lb. breakout
31,691-lb. operating weight

Refined PowerTech™ diesels deliver an impressive torque rise of 37, 41, and 54 percent in the 444J, 544J, and 624J, respectively.

444J, 544J, and 624J ride on a wider stance, providing additional lateral stability for handling heavy loads and work on rough terrain.

Extended service intervals and larger fuel tanks help maximize uptime.

Same-side ground-level daily service access makes routine tasks quick and easy.

Conveniently positioned switch module helps reduce operator fatigue with clearly visible backlit and sealed controls.

Standard air-ride armchair seat adjusts multiple ways for extra comfort.

Eleven automotive-style louvers including two directed at the pedals and independently adjustable defrosters provide effective airflow to help keep the glass clear and the pressurized cab comfortable.



1. Industry-leading 360-degree visibility gives a clear view of the work ahead and the jobsite around you.

2. Advanced, multi-language monitor with analog gauges and LED indicators provides:

Diagnostic readings of most sensors and switches, enabling technicians to quickly troubleshoot problems.

Vital and general operating information including transmission mode, gear, engine rpms, and ground speed.

Customized machine settings let you match operating characteristics to specific applications by preselecting transmission functions such as Quick-Shift and Auto-to-1st for maximum productivity.





Hard work never felt this easy.

From the convenient controls that customize machine operation, to the comfortable, fully adjustable air-ride armchair seat, the J-Series Loaders have everything your operators need to do their best. All-around visibility is unobstructed, and an improved HVAC system helps keep the view clear, the cab comfortable.

Your choice of single-lever joystick or two-lever pilot-operated controls and an all-new sealed switch module allow convenient control of multiple machine operations. Up-front, a state-of-the-art multifunction monitor with easy-to-read messaging, large analog gauges, and LED warning lights provides vital operating info at a glance.

More power and control means more productivity.



Want to increase productivity? Choose the J-Series Loaders. It's not just their impressive torque reserves and Power Bulge advantage that make them such powerful performers. Excavator-style hydraulics sense the load and deliver the power needed for smooth boom and bucket functions and fast work cycles.

You won't find a smoother shifting loader, either. The powershift torque converter transmission employs smart-shift technology to continuously evaluate speed and load conditions, and adjusts clutch-pack engagement to suit. For more productivity without a lot of extra effort.



Since the hydraulic system provides only the power required, there's no wasted horsepower or fuel.

Responsive steering and full 80-degree articulation increase maneuverability in tight quarters — for fast cycle times and fewer “three-point” turns.

Smart-shift technology ensures that gear changes are smooth as silk regardless of whether the bucket is empty or fully loaded.

When rpms drop below 2,200, the horsepower actually goes up. The John Deere Power Bulge advantage helps maintain good boom and bucket speed into the pile.



1

1. Choose from single-lever joystick or two-lever fingertip pilot-operated controls. Single-lever control can also be equipped with an optional fingertip FNR selector for convenient direction and full-range gear changes. Both controls also include John Deere's innovative Quick-Shift feature that allows pushbutton gear changes, one gear at a time.

2. Convenient sealed switch module gives fingertip control of numerous functions:

A. Boom height kick-out sets maximum desired dump height, while return-to-carry predetermines the lowered boom position. Use these two John Deere advantages to speed production in repetitive loading applications.

B. Programmable clutch cutoff increases productivity in all kinds of terrain. Simply select the slope at your dumpsite — level, small, or steep. When the brake pedal is depressed, the transmission disconnects while keeping engine speed high for fast boom cycles.



A



B



2

Large-capacity fuel tanks let you run longer between fill-ups for more uptime and productivity.

Wet-sleeve liners provide uniform engine cooling and longer durability than cast-in-block designs.

Service intervals for engine oil, transmission oil, and hydraulic oil have been extended to 500, 2,000, and 4,000 hours.

Standard features such as bypass-start protection, automatic park brake, convenient handholds, and slip-resistant steps help keep the operator out of harm's way.

1. Electrical distribution center utilizes highly reliable circuit-board technology and solid-state switches, eliminating numerous wiring harnesses, fuses, relays, and connectors.
2. Optional reversible fan automatically reverses every 30 minutes, ejecting debris from the radiator and coolers for more uptime and productivity. Or just hit a button to choose your own cleaning cycles.
3. Four steel plates support the far end of the boom pivot, extending the life of the pins and protecting the boom cylinder hoses.

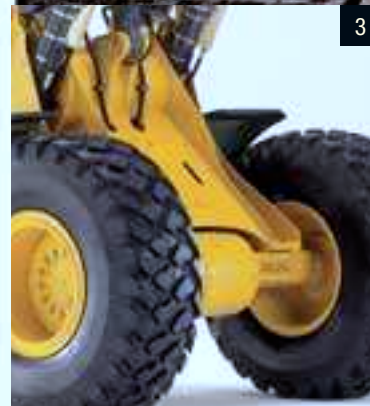

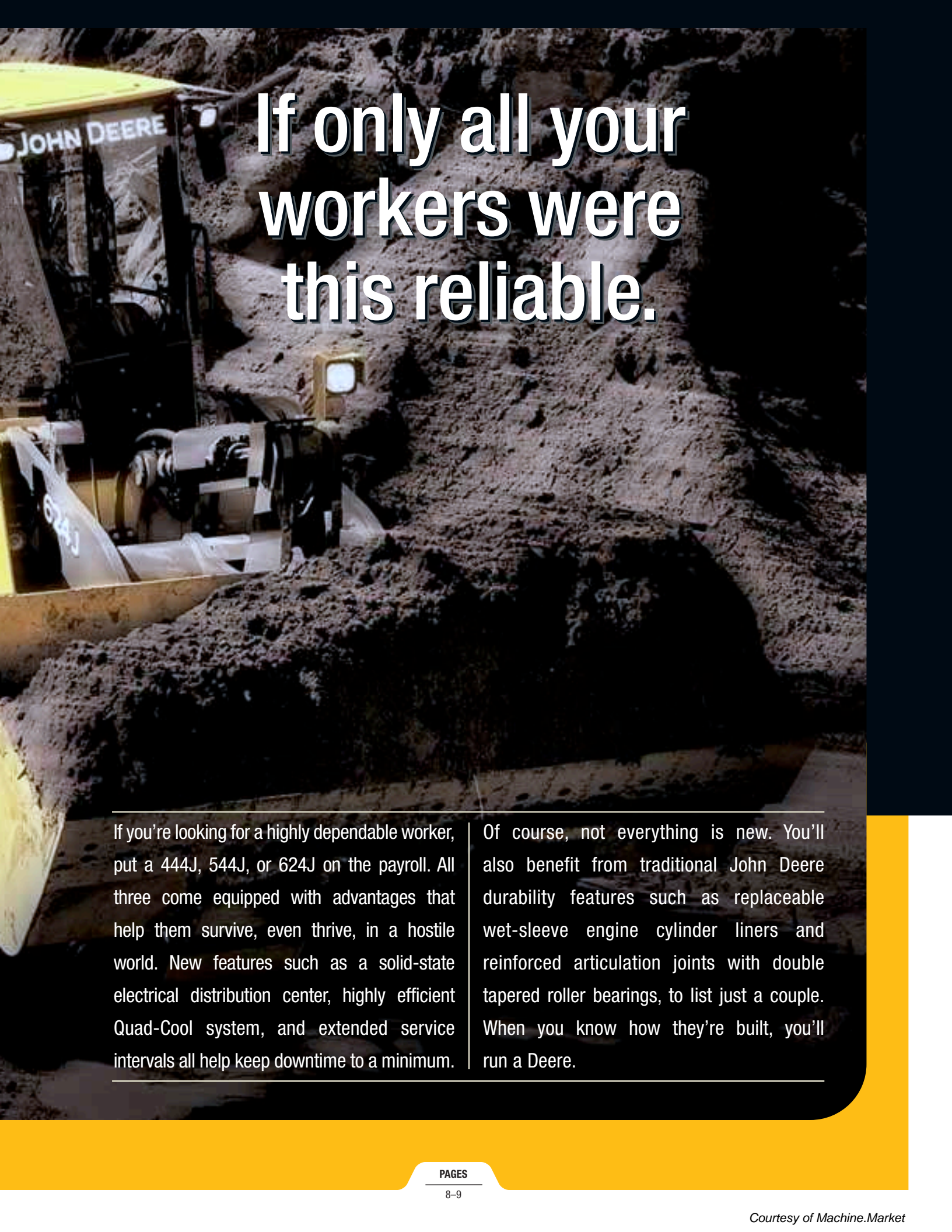

If only all your workers were this reliable.

If you're looking for a highly dependable worker, put a 444J, 544J, or 624J on the payroll. All three come equipped with advantages that help them survive, even thrive, in a hostile world. New features such as a solid-state electrical distribution center, highly efficient Quad-Cool system, and extended service intervals all help keep downtime to a minimum.

Of course, not everything is new. You'll also benefit from traditional John Deere durability features such as replaceable wet-sleeve engine cylinder liners and reinforced articulation joints with double tapered roller bearings, to list just a couple. When you know how they're built, you'll run a Deere.



Build one your way.

Who says you have to “settle” for a loader with the wrong axles, boom, bucket, or whatever? The 444J, 544J, and 624J are available with a wide variety of factory-

or field-installed options to fit a wide variety of work. So you can equip a loader with the features, tools, and attachments you need to maximize your efforts.



Available sound-suppression packages make J-Series cabs even quieter — some by as much as 5 dBA.

Axle options include front and rear locking differentials or front locking differential with conventional rear.

Corrosion package shields electrical components and connections for longer life.

Onboard weighing systems help you to load trucks to their full legal payload, for maximum productivity.



1. Equip your loader with the bucket teeth or edges that best suit your application. Easy-digging Fanggs™ teeth, interchangeable JAGZ™ edges, and special-duty Guardian Poly-Edges all deliver superior life and a host of other advantages for a wide variety of work.

2. Choose either single-lever joystick or two-lever fingertip control. Add up to five hydraulic functions.



3. Need to go higher? The factory-installed high-lift option extends lift height nearly a foot-and-a-half and is ideal for efficiently moving materials to new heights.



4. Ride-control option enables the hydraulic lift cylinders to act as shock absorbers and lets these loader navigate rough terrain more quickly without losing the load. Auto-actuation speed is adjustable between 2 and 15 mph.



5. Extra guarding and integrated “purpose-built” features go into the J-Series Waste Handlers. We’ve got what it takes for other heavy-duty applications, too.

6. Optional hydraulically activated Worksite Pro™ quick-coupler lets an operator switch attachments without leaving the cab.



Hydraulically driven fan runs only as needed — for efficient cooling and reduced fuel consumption.

Optional reversing fan automatically back-blows every 30 minutes to help keep cooler cores clean. Or hit the button to choose your own cleaning cycles.

All daily service points including fuel are on the left side for quick and convenient ground-level access.

Quad-Cool system keeps the radiator; air-conditioner condenser; intercooler; and hydraulic, transmission, and optional axle coolers isolated from engine heat for increased efficiency and durability.

Large service doors swing open wide, providing quick entry to the engine and Quad-Cool system compartments.

Three-millimeter perforations act as a “first filter,” preventing entry of most airborne debris. Both sides of all coolers are easily accessible for quick cleaning, if necessary.



We made ourselves even more accessible.

When it comes to helping you control daily operating costs, we're open to new ideas — and these loaders are packed with them. Take the Quad-Cool system, for example. It places major coolers in a unique boxed configuration that eliminates stacked coolers, for unsurpassed access and resistance to

plugging. We didn't stop there. Service intervals have been extended, and ground-level same-side service points help make quick work of the daily routine. The list of J-Series features that help minimize maintenance goes on and on. And so will the owning and operating cost savings you'll enjoy.

1. Vertical spin-on oil filters allow quick, no-spill changes. Extended transmission filter and engine and hydraulic oil service intervals contribute to low operating costs.

2. Greasing is less messy with centralized lube banks, providing easy access to difficult-to-reach zerks.

3. If something goes wrong, the advanced monitor gives diagnostic messages and even offers possible troubleshooting solutions to help get you back up and running more quickly.

4. Conveniently located, easy-to-read sight gauges let you check fluid levels at a glance.

5. Lockable compartment swings open, offering convenient ground-level access to batteries and electrical disconnect switch.

6. Your John Deere dealer has the parts and service you need to stay productive, and also offers a wide variety of preventative maintenance and support programs to help control costs.

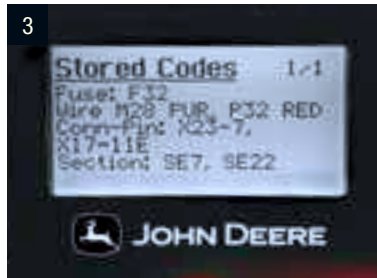

Specifications

Engine

444J

Type	John Deere PowerTech™ 4045H; certified to EPA Tier 2 emissions
Cylinders	4
Valves Per Cylinder	2
Displacement	276 cu. in. (4.5 L)
Net Peak Power	125 hp (90 kW) @ 2,000 rpm
Net Rated Power	115 hp (82 kW) @ 2,200 rpm
Net Peak Torque	375 lb.-ft. (505 Nm) @ 1,400 rpm
Net Torque Rise	37%
Net Power Bulge	10%
Fuel System	electronically controlled rotary pump-line-nozzle
Lube System	full-flow spin-on filter and integral cooler
Aspiration	turbocharged, charge air cooled
Air Cleaner	dual element dry type, restriction indicator in cab monitor for service
Fan Drive	hydraulically driven, proportionally controlled, fan aft of coolers
Electrical System	24 volt with 80-amp alternator
Batteries (two 12 volt)	950 CCA

Transmission

Type	countershaft-type power shift	
Torque Converter	single stage, single phase	
Shift Control	electronically modulated, adaptive, load and speed dependent	
Operator Interface	steering-column or joystick-mounted F-N-R and gear-select lever, kick-down button on hydraulic lever	
Shift Modes	auto/manual, auto to 1st or 2nd, kick down or kick up/down, three clutch cutoff settings adjustable on switch pad	
Travel Speeds*	<i>Forward</i>	<i>Reverse</i>
Gear 1	4.5 mph (7.2 km/h)	4.7 mph (7.5 km/h)
Gear 2	7.7 mph (12.4 km/h)	8.1 mph (13.1 km/h)
Gear 3	14.9 mph (24.0 km/h)	15.7 mph (25.3 km/h)
Gear 4	23.4 mph (37.7 km/h)	

*Equipped with 17.5-25 tires.

Axles/Brakes

Final Drives	heavy-duty mid-board planetary
Differentials	hydraulic locking front, conventional rear — standard; dual locking front and rear — optional
Rear Axle Oscillation, Stop to Stop*	24 deg.
Brakes (conform to SAE J1473, ISO3450)	
Service Brakes	hydraulically actuated, mid-board, self adjusting, wet multi-disc
Parking Brake	automatic spring applied, hydraulically released, oil cooled, multi-disc

*Equipped with 17.5-25 tires.

Tires

Choice of (with three-piece rims)	Tread Width	Width Over Tires	Change In Vertical Height
17.5R25 L-3	74.8 in. (1900 mm)	92.3 in. (2345 mm)	0 in. (0 mm)
17.5R25 L-2	74.8 in. (1900 mm)	92.9 in. (2359 mm)	- 0.5 in. (- 13 mm)
17.5-25 L-2*	74.8 in. (1900 mm)	92.9 in. (2359 mm)	- 0.4 in. (- 10 mm)
17.5-25 L-2	74.8 in. (1900 mm)	92.8 in. (2357 mm)	- 0.4 in. (- 10 mm)
17.5-25 L-3	74.8 in. (1900 mm)	92.8 in. (2357 mm)	- 0.3 in. (- 8 mm)
20.5R25 L-2	76.8 in. (1950 mm)	97.7 in. (2482 mm)	+ 2.8 in. (+ 70 mm)
20.5-25 L-2	76.8 in. (1950 mm)	98.6 in. (2504 mm)	+ 2.6 in. (+ 67 mm)
550/65R25 L-3	76.8 in. (1950 mm)	100.2 in. (2544 mm)	+ 1.8 in. (+ 47 mm)

*Equipped with one-piece rims.

Refill Capacities (U.S.)

Fuel Tank (with ground-level fueling)	65 gal. (246 L)
Cooling System	22 qt. (21 L)
Engine Lubrication, Including Full-Flow Spin-	
On Filter	18.5 qt. (17.5 L)
Powershift Transmission, Including Filter	19.5 qt. (18.5 L)

Refill Capacities (U.S.) (continued)

444J

Differential (each axle)	
Front	18 qt. (17 L)
Rear	18 qt. (17 L)
Loader Hydraulic Reservoir and Filters	25.5 gal. (96.5 L)
Wet-Disc Parking Brake	10 oz. (0.3 L)

Hydraulic System/Steering

Pump (loader and steering)	variable-displacement, axial-piston pump; closed-center, pressure-compensating system
Maximum Flow @ 2,350 rpm	37 gpm (140 L/m) @ 1,000 psi (6895 kPa)
Pressure	loader and steering relief 3,600 psi (24 850 kPa)
Loader Controls	two-function valve; single- or dual-lever controls; control lever lockout feature; optional third- and fourth-function valve with auxiliary lever
Steering (conforms to SAE J1511)	
Type	power, fully hydraulic
Pressure	3,600 psi (24 850 kPa) relief
Articulation Angle	80-deg. arc (40 deg. each direction)
Hydraulic Cycle Times	<i>Standard Z-Bar</i>
Raise	5.6 sec.
Dump	1.0 sec.
Lower	2.4 sec. (float down) / 3.4 sec. (power down)
Total	9.0 sec.
	<i>High-Lift Z-Bar</i>
	5.6 sec.
	1.7 sec.
	2.4 sec. (float down) / 3.4 sec. (power down)
	9.7 sec.
Maximum Lift Capacity (with 2.0-cu.-yd. [1.5 m ³] bucket with bolt-on edge)	
Lift at Ground Level	22,403 lb. (10 160 kg)
Lift at Maximum Height	10,719 lb. (4861 kg)
Turning Radius (measured to centerline of outside tire)	15 ft. 5 in. (4703 mm)

Dimensions with Pin-On Bucket

	<i>Standard Z-Bar</i>	<i>High-Lift Z-Bar</i>
A Height to Top of Cab and Canopy	10 ft. 4.2 in. (3154 mm)	10 ft. 4.2 in. (3154 mm)
B Height to Top of Exhaust	10 ft. 3.6 in. (3140 mm)	10 ft. 3.6 in. (3140 mm)
C Ground Clearance	15.6 in. (395.5 mm)	15.6 in. (395.5 mm)
D Length from Centerline to Front Axle	54.1 in. (1375 mm)	54.1 in. (1375 mm)
E Wheelbase	108.3 in. (2750 mm)	108.3 in. (2750 mm)
F Dump Clearance	(see page 17)	(see page 18)
G Height to Hinge Pin, Fully Raised	11 ft. 10 in. (3597 mm)	13 ft. 0 in. (3975 mm)
H Dump Reach	(see page 17)	(see page 18)
I Maximum Digging Depth	3.4 in. (85 mm)	4.1 in. (105 mm)
J Overall Length	(see page 17)	(see page 18)
K Maximum Rollback at Ground Level	39 deg.	39.5 deg.
L Maximum Rollback, Boom Fully Raised	55 deg.	55 deg.
M Maximum Bucket Angle, Fully Raised	50 deg.	50 deg.

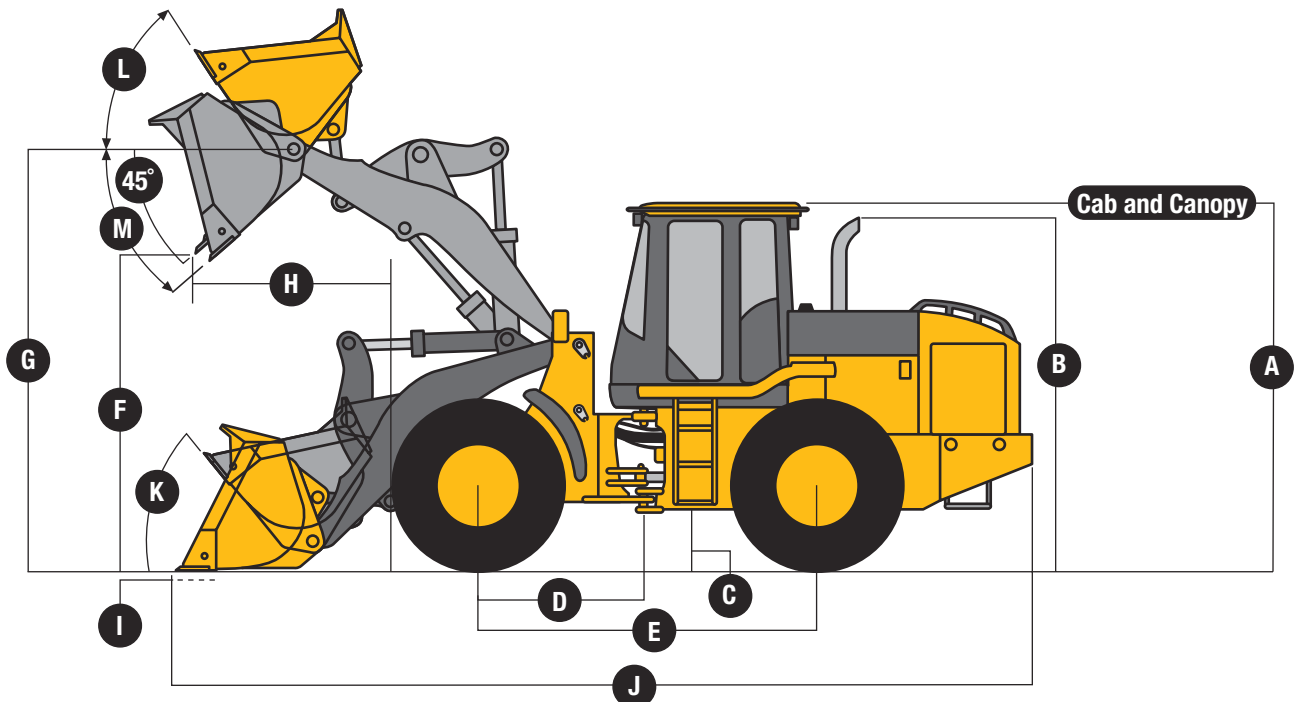

Dimensions with Quick-Coupler and Bucket

444J

	<i>Standard Z-Bar</i>	<i>High-Lift Z-Bar</i>
A Dump Clearance	(see page 17)	(see page 18)
B Dump Reach	(see page 17)	(see page 18)
C Maximum Digging Depth	3.9 in. (99 mm)	4.7 in. (119 mm)
D Height to Hinge Pin, Fully Raised	11 ft. 10 in. (3597 mm)	13 ft. 0 in. (3975 mm)
E Overall Length	(see page 17)	(see page 18)
F Maximum Rollback, Boom Fully Raised	57 deg.	48 deg.
G Maximum Bucket Discharge Angle, Fully Raised	54 deg.	49 deg.
H Maximum Rollback at Ground Level	38 deg.	38 deg.

444J LOADER WITH QUICK-COUPLER AND BUCKET

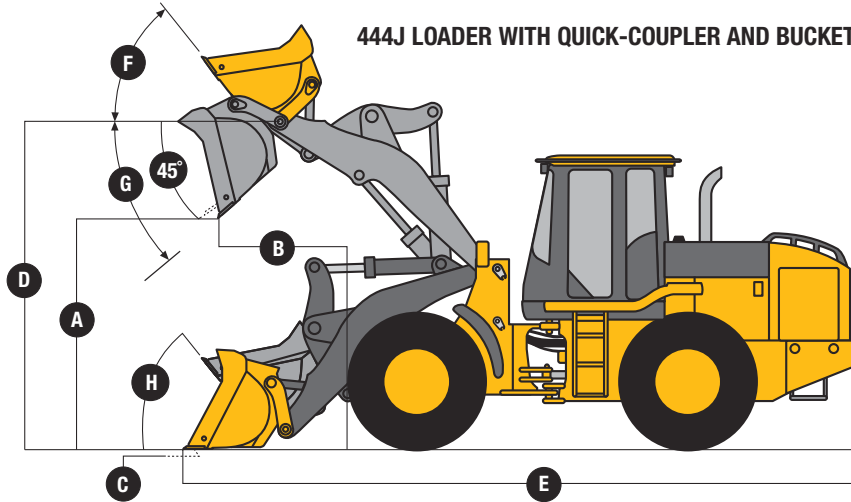

Dimensions with Quick-Coupler and Construction Fork

444J

	<i>Standard Z-Bar</i>	<i>High-Lift Z-Bar</i>
A Reach, Fully Raised	2 ft. 10 in. (874 mm)	2 ft. 11 in. (880 mm)
B Fork Height, Fully Raised	11 ft. 0 in. (3356 mm)	12 ft. 2 in. (3713 mm)
C Maximum Reach, Fork Level	5 ft. 2 in. (1585 mm)	6 ft. 1 in. (1851 mm)
D Fork Height, Maximum Reach	5 ft. 4 in. (1624 mm)	5 ft. 4 in. (1624 mm)
E Reach, Ground Level	3 ft. 2 in. (974 mm)	4 ft. 4 in. (1316 mm)
F Depth Below Ground	4 in. (100 mm)	4 in. (100 mm)
G Tine Length	(see page 18)	(see page 19)
H Overall Length	(see page 18)	(see page 19)

444J LOADER WITH QUICK-COUPLER AND CONSTRUCTION FORK

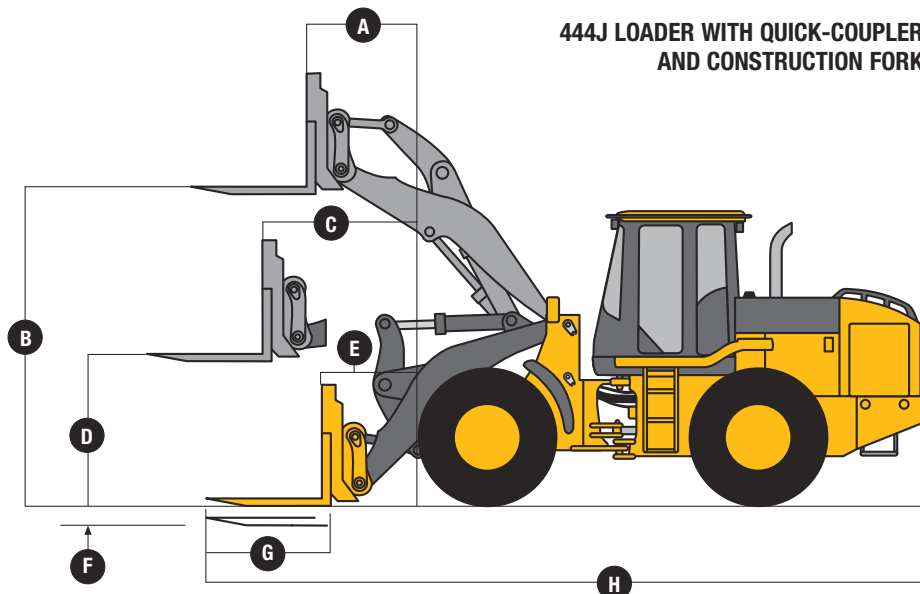

**Standard Z-Bar Information
with Pin-On-Type Bucket**

444J

Bucket Type/Size	General Purpose w/Bolt-On Edge	General Purpose w/Bolt-On Edge	General Purpose w/Teeth and Segments
Capacity, Heaped SAE	2.5 cu. yd. (1.9 m ³)	2.0 cu. yd. (1.5 m ³)	2.0 cu. yd. (1.5 m ³)
Capacity, Struck SAE	2.1 cu. yd. (1.6 m ³)	1.6 cu. yd. (1.2 m ³)	1.6 cu. yd. (1.2 m ³)
Bucket Weight	1,973 lb. (895 kg)	1,827 lb. (829 kg)	1,940 lb. (880 kg)
Bucket Width	100.4 in. (2550 mm)	100.4 in. (2550 mm)	100.4 in. (2550 mm)
Breakout Force, SAE J732C	18,104 lb. (8212 kg)	20,531 lb. (9313 kg)	18,437 lb. (8363 kg)
Tipping Load, Straight	18,340 lb. (8319 kg)	18,719 lb. (8491 kg)	18,613 lb. (8443 kg)
Tipping Load, 40-Degree Full Turn, SAE	15,639 lb. (7094 kg)	15,983 lb. (7250 kg)	15,880 lb. (7203 kg)
Reach, 45-Degree Dump, 7-ft. (2.13 m)			
Clearance	56.1 in. (1478 mm)	54.6 in. (1388 mm)	56.4 in. (1433 mm)
Reach, 45-Degree Dump, Full Height	40.3 in. (1024 mm)	37.2 in. (945 mm)	40.3 in. (1023 mm)
Dump Clearance, 45 Degree, Full Height	105.3 in. (2674 mm)	108.0 in. (2752 mm)	105.8 in. (2688 mm)
Overall Length, Bucket on Ground	22 ft. 2 in. (6752 mm)	21 ft. 9 in. (6633 mm)	22 ft. 1 in. (6734 mm)
Loader Clearance Circle, Bucket In Carry			
Position	36 ft. 3 in. (11 053 mm)	36 ft. 0 in. (10 972 mm)	36 ft. 2 in. (11 029 mm)
Operating Weight	22,645 lb. (10 272 kg)	22,500 lb. (10 206 kg)	22,612 lb. (10 257 kg)

Loader operating information is based on machine with standard equipment; cab; rear cast bumper/counterweight; 20.5R25 tires; ROPS cab; 175-lb. (79 kg) operator; and full fuel tank. This information is affected by tire size, ballast, and different attachments.

Adjustments to Operating Weights for Standard Z-Bar with Pin-On-Type Buckets or Quick-Coupler and Hook-On-Type Buckets

Adjustments to operating weights and tipping loads for 2.5-cu.-yd. (1.9 m³) general-purpose bucket with bolt-on cutting edge

Add (+) or deduct (-) lb. (kg) as indicated for	Operating Weight	Tipping Load, Straight	Tipping Load, 40-Degree Full Turn, SAE
loaders with three-piece rims and			
17.5R25 L-3 tires	0 lb. (0 kg)	0 lb. (0 kg)	0 lb. (0 kg)
17.5R25 L-2 tires	- 228 lb. (- 104 kg)	- 150 lb. (- 68 kg)	- 131 lb. (- 60 kg)
17.5-25 L-2 tires*	- 544 lb. (- 247 kg)	- 357 lb. (- 162 kg)	- 310 lb. (- 140 kg)
17.5-25 L-2 tires	- 496 lb. (- 225 kg)	- 325 lb. (- 148 kg)	- 284 lb. (- 129 kg)
17.5-25 L-3 tires	- 460 lb. (- 209 kg)	- 302 lb. (- 137 kg)	- 262 lb. (- 119 kg)
20.5R25 L-2 tires**	+ 412 lb. (+ 187 kg)	+ 270 lb. (+ 123 kg)	+ 235 lb. (+ 107 kg)
20.5-25 L-2 tires**	+ 92 lb. (+ 42 kg)	+ 61 lb. (+ 28 kg)	+ 53 lb. (+ 24 kg)
550/65R25 L-3 tires**	+ 1,316 lb. (+ 598 kg)	+ 863 lb. (+ 392 kg)	+ 752 lb. (+ 341 kg)
CaCl ₂ in 17.5-25 rear tires**	+ 1,179 lb. (+ 535 kg)	+ 1,546 lb. (+ 701 kg)	+ 1,344 lb. (+610 kg)
Optional rear cast bumper/counterweight (removed)	N/A	N/A	N/A

*Equipped with one-piece rims.

**CaCl₂ not recommended with 20.5R25, 20.5-25, and 550/65R25 tires.

Standard Z-Bar Information with Quick-Coupler and Bucket

Bucket Type/Size	General Purpose w/Bolt-On Edge	General Purpose w/Bolt-On Edge
Capacity, Heaped SAE	2.5 cu. yd. (1.9 m ³)	2.0 cu. yd. (1.5 m ³)
Capacity, Struck SAE	2.1 cu. yd. (1.6 m ³)	1.6 cu. yd. (1.2 m ³)
Bucket Weight with Coupler	2,806 lb. (1273 kg)	2,643 lb. (1199 kg)
Bucket Width	100.4 in. (2550 mm)	100.4 in. (2550 mm)
Breakout Force, SAE J732C	14,762 lb. (6696 kg)	15,765 lb. (7151 kg)
Tipping Load, Straight	17,108 lb. (7760 kg)	17,310 lb. (7852 kg)
Tipping Load, 40-Degree Full Turn, SAE	14,296 lb. (6485 kg)	14,680 lb. (6659 kg)
Reach, 45-Degree Dump, 7-ft. (2.13 m)		
Clearance	58.5 in. (1485 mm)	57.5 in. (1461 mm)
Reach, 45-Degree Dump, Full Height	45.7 in. (1160 mm)	43.8 in. (1112 mm)
Dump Clearance, 45 Degree, Full Height	100.0 in. (2542 mm)	101.6 in. (2581 mm)
Overall Length, Bucket on Ground	22 ft. 10 in. (6955 mm)	22 ft. 7 in. (6887 mm)
Loader Clearance Circle, Bucket In Carry		
Position	36 ft. 9 in. (11 192 mm)	36 ft. 6 in. (11 134 mm)
Operating Weight	23,481 lb. (10 651 kg)	23,316 lb. (10 576 kg)

Loader operating information is based on machine with standard equipment; cab; rear cast bumper/counterweight; 20.5R25 tires; ROPS cab; 175-lb. (79 kg) operator; and full fuel tank. This information is affected by tire size, ballast, and different attachments.

Standard Z-Bar Information with

Quick-Coupler and Construction Fork 444J

Tine Length	48 in. (1220 mm)	60 in. (1525 mm)
Overall Length	24 ft. 4 in. (7407 mm)	25 ft. 4 in. (7710 mm)
Tipping Load, Straight (fork level, load centered forward 24 in. [610 mm] on 48-in. [1220 mm] tine and 30 in. [762 mm] on 60-in. [1525 mm] tine)	11,449 lb. (5193 kg)	10,759 lb. (4880 kg)
Tipping Load, 40-Degree Full Turn (fork level, load centered forward 24 in. [610 mm] on 48-in. [1220 mm] and 30 in. [762 mm] on 60-in. tine [1525 mm] tine)	9,739 lb. (4418 kg)	9,136 lb. (4144 kg)
Operating Weight	22,626 lb. (10 261 kg)	22,727 lb. (10 307 kg)

High-Lift Z-Bar Information with Pin-On-Type Bucket

	General Purpose w/Bolt-On Edge	General Purpose w/Bolt-On Edge
Bucket Type/Size		
Capacity, Heaped SAE	2.5 cu. yd. (1.9 m ³)	2.0 cu. yd. (1.5 m ³)
Capacity, Struck SAE	2.1 cu. yd. (1.6 m ³)	1.6 cu. yd. (1.2 m ³)
Bucket Weight	1,973 lb. (895 kg)	1,827 lb. (829 kg)
Bucket Width	100.4 in. (2550 mm)	100.4 in. (2550 mm)
Breakout Force, SAE J732C	16,655 lb. (7555 kg)	18,946 lb. (8594 kg)
Tipping Load, Straight	14,995 lb. (6802 kg)	15,346 lb. (6961 kg)
Tipping Load, 40-Degree Full Turn, SAE	12,736 lb. (5777 kg)	13,055 lb. (5922 kg)
Reach, 45-Degree Dump, 7-ft. (2.13 m)		
Clearance	69.3 in. (1759 mm)	67.6 in. (1715 mm)
Reach, 45-Degree Dump, Full Height	41.3 in. (1050 mm)	38.3 in. (972 mm)
Dump Clearance, 45 Degree, Full Height	120.1 in. (3052 mm)	123.3 in. (3130 mm)
Overall Length, Bucket on Ground	23 ft. 5 in. (7133 mm)	23 ft. 0 in. (7015 mm)
Loader Clearance Circle, Bucket In Carry		
Position	37 ft. 5 in. (11 401 mm)	37 ft. 1 in. (11 306 mm)
Operating Weight	22,877 lb. (10 377 kg)	22,731 lb. (10 311 kg)

Loader operating information is based on machine with standard equipment; cab; rear cast bumper/counterweight; 20.5R25 tires; ROPS cab; 175-lb. (79 kg) operator; and full fuel tank. This information is affected by tire size, ballast, and different attachments.

Adjustments to Operating Weights for High-Lift Z-Bar with Pin-On-Type Buckets or Quick-Coupler and Hook-On-Type Buckets

Adjustments to operating weights and tipping loads for 2.5-cu.-yd. (1.9 m³) general-purpose bucket with bolt-on cutting edge

Add (+) or deduct (-) lb. (kg) as indicated for

loaders with three-piece rims and	Operating Weight	Tipping Load, Straight	Tipping Load, 40-Degree Full Turn, SAE
17.5R25 L-3 tires	0 lb. (0 kg)	0 lb. (0 kg)	0 lb. (0 kg)
17.5R25 L-2 tires	- 228 lb. (- 104 kg)	- 131 lb. (- 60 kg)	- 112 lb. (- 51 kg)
17.5-25 L-2 tires*	- 544 lb. (- 247 kg)	- 313 lb. (- 142 kg)	- 267 lb. (- 121 kg)
17.5-25 L-2 tires	- 496 lb. (- 225 kg)	- 285 lb. (- 129 kg)	- 243 lb. (- 110 kg)
17.5-25 L-3 tires	- 460 lb. (- 209 kg)	- 265 lb. (- 120 kg)	- 225 lb. (- 102 kg)
20.5R25 L-2 tires**	+ 412 lb. (+ 187 kg)	+ 237 lb. (+ 108 kg)	+ 202 lb. (+ 92 kg)
20.5-25 L-2 tires**	+ 92 lb. (+ 42 kg)	+ 53 lb. (+ 24 kg)	+ 45 lb. (+ 21 kg)
550/65R25 L-3 tires**	+ 1,316 lb. (+ 598 kg)	+ 757 lb. (+ 344 kg)	+ 645 lb. (+ 293 kg)
CaCl ₂ in 17.5-25 rear tires**	+ 1,179 lb. (+ 535 kg)	+ 1,356 lb. (+ 615 kg)	+ 1,155 lb. (+ 524 kg)
Optional rear cast bumper/counterweight (removed)	N/A	N/A	N/A

*Equipped with one-piece rims.

**CaCl₂ not recommended with 20.5R25, 20.5-25, and 550/65R25 tires.

High-Lift Z-Bar Information with Quick-Coupler and Bucket

444J

Bucket Type/Size	General Purpose w/Bolt-On Edge	General Purpose w/Bolt-On Edge
Capacity, Heaped SAE	2.5 cu. yd. (1.9 m ³)	2.0 cu. yd. (1.5 m ³)
Capacity, Struck SAE	2.1 cu. yd. (1.6 m ³)	1.6 cu. yd. (1.2 m ³)
Bucket Weight with Coupler	2,806 lb. (1273 kg)	2,643 lb. (1199 kg)
Bucket Width	100.4 in. (2550 mm)	100.4 in. (2550 mm)
Breakout Force, SAE J732C	13,552 lb. (6146 kg)	14,502 lb. (6577 kg)
Tipping Load, Straight	13,717 lb. (6221 kg)	14,094 lb. (6392 kg)
Tipping Load, 40-Degree Full Turn, SAE	11,545 lb. (5236 kg)	11,889 lb. (5392 kg)
Reach, 45-Degree Dump, 7-ft. (2.13 m)		
Clearance	71.5 in. (1817 mm)	70.9 in. (1801 mm)
Reach, 45-Degree Dump, Full Height	46.4 in. (1179 mm)	44.8 in. (1139 mm)
Dump Clearance, 45 Degree, Full Height	114.7 in. (2914 mm)	116.5 in. (2959 mm)
Overall Length, Bucket on Ground	24 ft. 1 in. (7333 mm)	23 ft. 10 in. (7267 mm)
Loader Clearance Circle, Bucket In Carry		
Position	37 ft. 11 in. (11 553 mm)	37 ft. 8 in. (11 486 mm)
Operating Weight	23,717 lb. (10 756 kg)	23,951 lb. (10 682 kg)

Loader operating information is based on machine with standard equipment; cab; rear cast bumper/counterweight; 20.5R25 tires; ROPS cab; 175-lb. (79 kg) operator; and full fuel tank. This information is affected by tire size, ballast, and different attachments.

High-Lift Z-Bar Information with Quick-Coupler and Construction Fork

Tine Length	48 in. (1220 mm)	60 in. (1525 mm)
Overall Length	25 ft. 5 in. (7749 mm)	26 ft. 5 in. (8052 mm)
Tipping Load, Straight (fork level, load centered forward 24 in. [610 mm] on 48-in. [1220 mm] tine and 30 in. [762 mm] on 60-in. [1525 mm] tine)	11,674 lb. (5295 kg)	10,950 lb. (4967 kg)
Tipping Load, 40-Degree Full Turn (fork level, load centered forward 24 in. [610 mm] on 48-in. [1220 mm] tine and 30 in. [762 mm] on 60-in. [1525 mm] tine)	9,898 lb. (4490 kg)	9,267 lb. (4203 kg)
Operating Weight	22,857 lb. (10 366 kg)	22,959 lb. (10 412 kg)

Standard Z-Bar Pin-On Bucket Selection Guide*

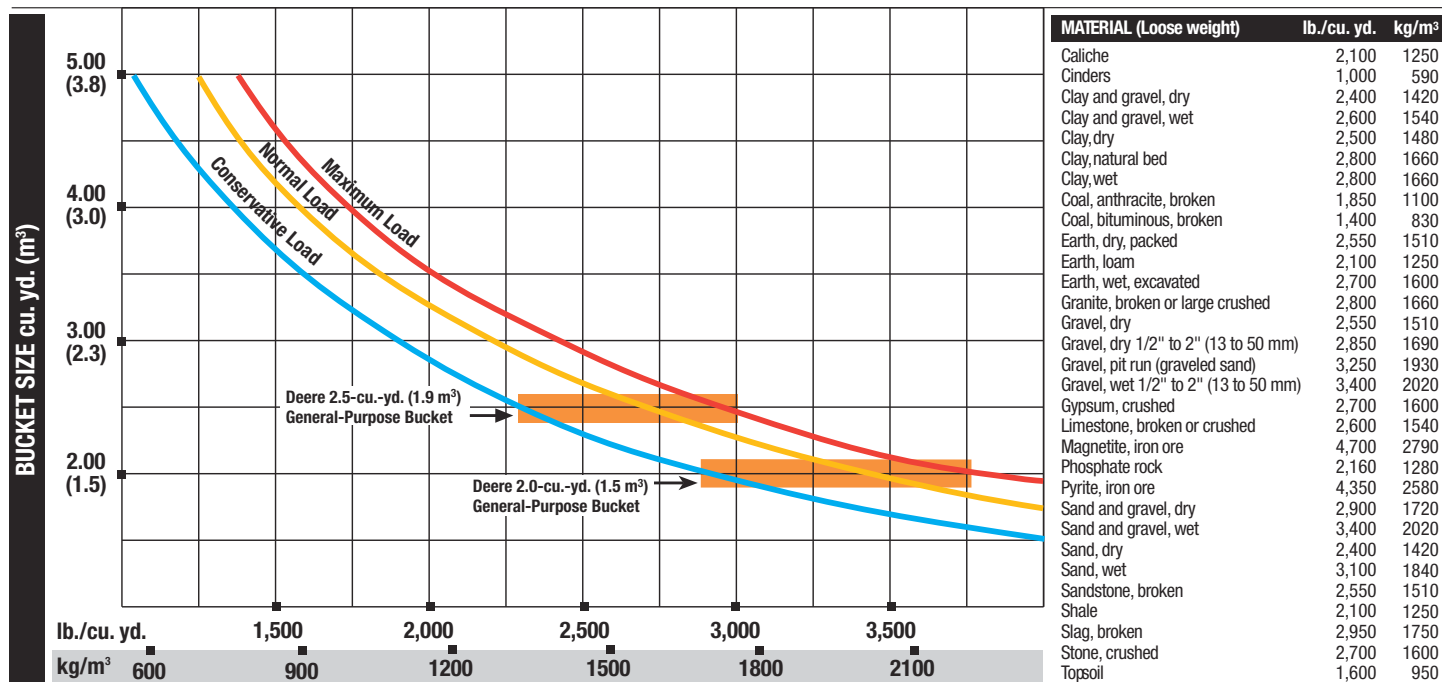

* This guide, representing bucket sizes not necessarily manufactured by Deere, will help you in selecting proper bucket size for material density, loader configuration, and operating conditions. Optimum bucket size is determined after adding or subtracting all tipping load changes due to optional equipment. The "conservative load" line on this guide is recommended when operating in conditions such as soft ground and unlevel surfaces. The "maximum load" condition on this guide is sometimes utilized when operating on firm ground and level surfaces.

Specifications

Engine 544J

Type	John Deere PowerTech 6068H; certified to EPA Tier 2 emissions
Cylinders	6
Valves Per Cylinder	2
Displacement	414 cu. in. (6.8 L)
Net Peak Power	160 hp (116 kW) @ 1,900 rpm
Net Rated Power	145 hp (100 kW) @ 2,200 rpm
Net Peak Torque	485 lb.-ft. (650 Nm) @ 1,400 rpm
Net Torque Rise	41%
Net Power Bulge	11%
Fuel System	electronically controlled rotary pump-line-nozzle
Lube System	full-flow spin-on filter and integral cooler
Aspiration	turbocharged, charge air cooled
Air Cleaner	dual element dry type, restriction indicator in cab monitor for service
Fan Drive	hydraulically driven, proportionally controlled, fan aft of coolers
Electrical System	24 volt with 80-amp alternator
Batteries (two 12 volt)	950 CCA

Transmission

Type	countershaft-type power shift	
Torque Converter	single stage, single phase	
Shift Control	electronically modulated, adaptive, load and speed dependent	
Operator Interface	steering-column or joystick-mounted F-N-R and gear-select lever, kick-down button on hydraulic lever	
Shift Modes	auto/manual, auto to 1st or 2nd, kick down or kick up/down, three clutch cutoff settings adjustable on switch pad	
Travel Speeds*	<i>Forward</i>	<i>Reverse</i>
Gear 1	4.3 mph (6.9 km/h)	4.5 mph (7.3 km/h)
Gear 2	7.4 mph (11.9 km/h)	7.8 mph (12.6 km/h)
Gear 3	14.2 mph (22.8 km/h)	15.0 mph (24.1 km/h)
Gear 4	23.8 mph (38.4 km/h)	

*Equipped with 20.5-25 tires.

Axles/Brakes

Final Drives	heavy-duty inboard planetary
Differentials	hydraulic locking front, conventional rear — standard; dual locking front and rear — optional
Rear Axle Oscillation, Stop to Stop*	24 deg.
Brakes (conform to SAE J1473, ISO3450)	
Service Brakes	hydraulically actuated, inboard, carrier mounted, pressure oil cooled, self adjusting, multi-disc
Parking Brake	automatic spring applied, hydraulically released, oil cooled, multi-disc

*Equipped with 20.5-25 tires.

Tires

Choice of (with three-piece rims)	Tread Width	Width Over Tires	Change In Vertical Height
20.5R25 L-3	76.8 in. (1950 mm)	97.7 in. (2482 mm)	0 in. (0 mm)
20.5R25 L-2	76.8 in. (1950 mm)	97.7 in. (2482 mm)	+ 1.45 in. (+ 37 mm)
20.5-25 L-2	76.8 in. (1950 mm)	97.7 in. (2483 mm)	- 0.27 in. (- 7 mm)
20.5-25 L-3	76.8 in. (1950 mm)	97.9 in. (2488 mm)	- 0.04 in. (- 1 mm)
600/65R25 L-3	76.8 in. (1950 mm)	100.2 in. (2544 mm)	- 0.83 in. (- 21 mm)
23.1-26 Logger*	84.0 in. (2136 mm)	107.2 in. (2723 mm)	+ 1.9 in. (+ 48 mm)

*Equipped with one-piece rims.

Refill Capacities (U.S.)

Fuel Tank (with ground-level fueling)	85 gal. (322 L)
Cooling System	22 qt. (21 L)
Engine Lubrication, Including Full-Flow Spin-On Filter	19.5 qt. (18.5 L)
Powershift Transmission, Including Filter	19.5 qt. (18.5 L)

Differential (each axle)	
Front	19 qt. (18 L)
Rear	19 qt. (18 L)
Loader Hydraulic Reservoir and Filters	25.5 gal. (96.5 L)
Wet-Disc Parking Brake	10 oz. (0.3 L)

Hydraulic System/Steering

Pump (loader and steering)	variable-displacement, axial-piston pump; closed-center, pressure-compensating system	
Maximum Flow @ 2,350 rpm	50 gpm (189 L/m) @ 1,000 psi (6895 kPa)	
Pressure	loader and steering relief 3,650 psi (25 167 kPa)	
Loader Controls	two-function valve; single- or dual-lever controls; control lever lockout feature; optional third- and fourth-function valve with auxiliary lever	
Steering (conforms to SAE J1511)		
Type	power, fully hydraulic	
Pressure	3,650 psi (25 167 kPa) relief	
Articulation Angle	80-deg. arc (40 deg. each direction)	
Hydraulic Cycle Times	<i>Standard Z-Bar</i>	<i>High-Lift Z-Bar</i>
Raise	5.7 sec.	5.7 sec.
Dump	1.2 sec.	1.2 sec.
Lower	3.2 sec. (float down) / 3.3 sec. (power down)	3.2 sec. (float down) / 3.3 sec. (power down)
Total	10.1 sec.	10.1 sec.
Maximum Lift Capacity (with 2.5-cu.-yd. [1.9 m ³] bucket with bolt-on edge)		
Lift at Ground Level	29,596 lb. (13 422 kg)	26,074 lb. (11 835 kg)
Lift at Maximum Height	14,904 lb. (6759 kg)	12,996 lb. (5894 kg)
Turning Radius (measured to centerline of outside tire)	16 ft. 3 in. (4959 mm)	16 ft. 3 in. (4959 mm)

Dimensions with Pin-On Bucket

	<i>Standard Z-Bar</i>	<i>High-Lift Z-Bar</i>
A Height to Top of Cab and Canopy	10 ft. 7.6 in. (3241 mm)	10 ft. 7.6 in. (3241 mm)
B Height to Top of Exhaust	10 ft. 7.0 in. (3227 mm)	10 ft. 7.0 in. (3227 mm)
C Ground Clearance	17.7 in. (450.5 mm)	17.7 in. (450.5 mm)
D Length from Centerline to Front Axle	57.1 in. (1450 mm)	57.1 in. (1450 mm)
E Wheelbase	114.2 in. (2900 mm)	114.2 in. (2900 mm)
F Dump Clearance	(see page 23)	(see page 24)
G Height to Hinge Pin, Fully Raised	12 ft. 7 in. (3836 mm)	13 ft. 9 in. (4188 mm)
H Dump Reach	(see page 23)	(see page 24)
I Maximum Digging Depth	3.25 in. (83 mm)	6.5 in. (165 mm)
J Overall Length	(see page 23)	(see page 24)
K Maximum Rollback at Ground Level	41 deg.	41 deg.
L Maximum Rollback, Boom Fully Raised	55 deg.	55 deg.
M Maximum Bucket Angle, Fully Raised	50 deg.	50 deg.

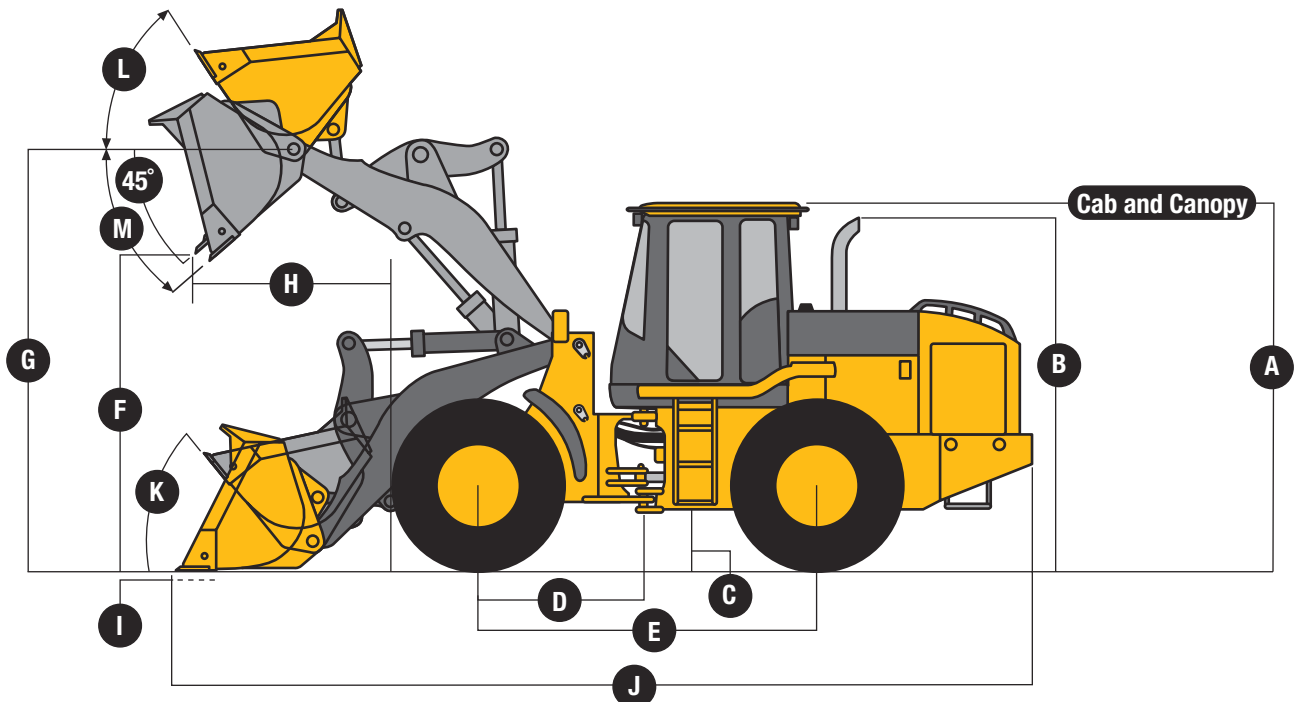

Dimensions with Quick-Coupler and Bucket

	544J <i>Standard Z-Bar</i> (see page 23)	<i>High-Lift Z-Bar</i> (see page 24)
A Dump Clearance	(see page 23)	(see page 24)
B Dump Reach	(see page 23)	(see page 24)
C Maximum Digging Depth	5.5 in. (139 mm)	8.7 in. (221 mm)
D Height to Hinge Pin, Fully Raised	12 ft. 7 in. (3836 mm)	13 ft. 9 in. (4188 mm)
E Overall Length	(see page 23)	(see page 24)
F Maximum Rollback, Boom Fully Raised	55 deg.	49 deg.
G Maximum Bucket Discharge Angle, Fully Raised	55 deg.	51 deg.
H Maximum Rollback at Ground Level	42 deg.	41 deg.

544J LOADER WITH QUICK-COUPLER AND BUCKET

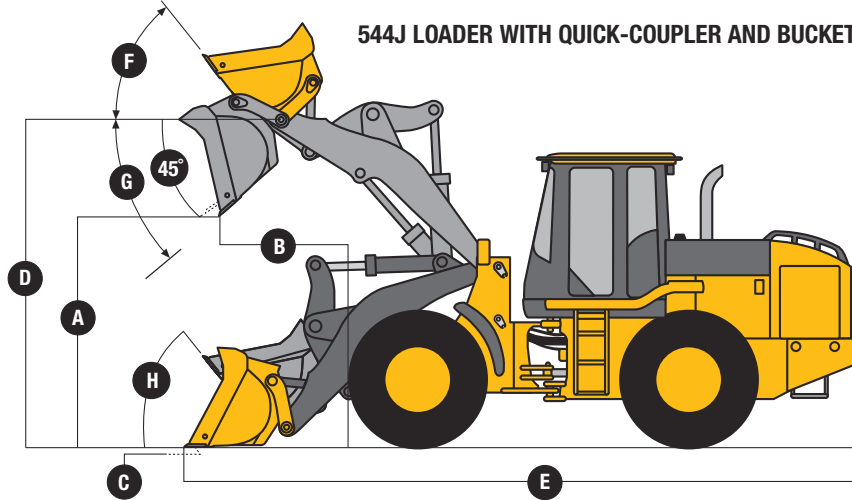

Dimensions with Quick-Coupler and Construction Fork

	544J <i>Standard Z-Bar</i>	<i>High-Lift Z-Bar</i>
A Reach, Fully Raised	2 ft. 6 in. (758 mm)	2 ft. 6 in. (760 mm)
B Fork Height, Fully Raised	11 ft. 9 in. (3574 mm)	12 ft. 11 in. (3926 mm)
C Maximum Reach, Fork Level	5 ft. 1 in. (1546 mm)	5 ft. 11 in. (1810 mm)
D Fork Height, Maximum Reach	5 ft. 7 in. (1705 mm)	5 ft. 7 in. (1705 mm)
E Reach, Ground Level	3 ft. 0 in. (912 mm)	4 ft. 1 in. (1249 mm)
F Depth Below Ground	1.2 in. (30 mm)	1.2 in. (30 mm)
G Tine Length	(see page 24)	(see page 25)
H Overall Length	(see page 24)	(see page 25)

544J LOADER WITH QUICK-COUPLER AND CONSTRUCTION FORK

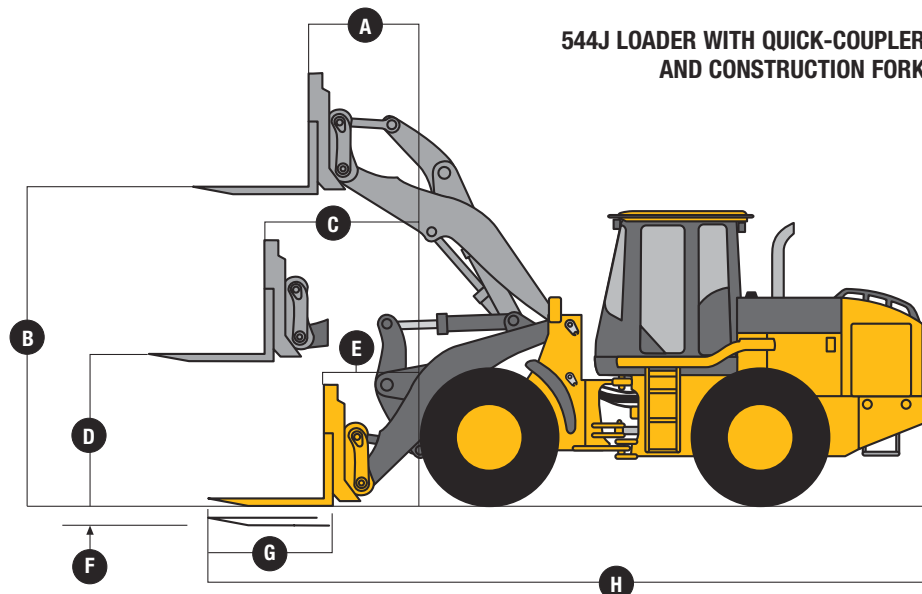

**Standard Z-Bar Information
with Pin-On-Type Bucket**

544J

	<i>Narrow General Purpose w/Bolt-On Edge</i>	<i>Wide General Purpose w/Bolt-On Edge</i>	<i>General Purpose w/Bolt-On Edge</i>	<i>General Purpose w/Teeth and Segments</i>
Bucket Type/Size				
Capacity, Heaped SAE	3.0 cu. yd. (2.3 m ³)	3.0 cu. yd. (2.3 m ³)	2.5 cu. yd. (1.9 m ³)	2.5 cu. yd. (1.9 m ³)
Capacity, Struck SAE	2.6 cu. yd. (2.0 m ³)	2.6 cu. yd. (2.0 m ³)	2.1 cu. yd. (1.6 m ³)	2.1 cu. yd. (1.6 m ³)
Bucket Weight	2,400 lb. (1089 kg)	2,617 lb. (1187 kg)	2,061 lb. (935 kg)	2,173 lb. (986 kg)
Bucket Width	100.4 in. (2550 mm)	105.9 in. (2690 mm)	100.4 in. (2550 mm)	100.4 in. (2550 mm)
Breakout Force, SAE J732C	22,672 lb. (10 284 kg)	24,250 lb. (11 000 kg)	26,770 lb. (12 143 kg)	24,292 lb. (11 019 kg)
Tipping Load, Straight	22,801 lb. (10 016 kg)	21,993 lb. (9976 kg)	22,798 lb. (10 341 kg)	22,698 lb. (10 296 kg)
Tipping Load, 40-Degree Full Turn, SAE	18,752 lb. (8506 kg)	18,653 lb. (8461 kg)	19,422 lb. (8810 kg)	19,325 lb. (8766 kg)
Reach, 45-Degree Dump, 7-ft. (2.13 m)				
Clearance	58.5 in. (1486 mm)	57.2 in. (1453 mm)	56.22 in. (1428 mm)	58.0 in. (1475 mm)
Reach, 45-Degree Dump, Full Height	39.3 in. (997 mm)	37.0 in. (939 mm)	34.7 in. (882 mm)	37.8 in. (959 mm)
Dump Clearance, 45 Degree, Full Height	110 in. (2787 mm)	111 in. (2837 mm)	114 in. (2904 mm)	112 in. (2840 mm)
Overall Length, Bucket on Ground	24 ft. 3 in. (7385 mm)	23 ft. 11 in. (7281 mm)	23 ft. 7 in. (7184 mm)	23 ft. 10 in. (7283 mm)
Loader Clearance Circle, Bucket In Carry				
Position	37 ft. 10 in. (11 547 mm)	38 ft. 2 in. (11 630 mm)	37 ft. 7 in. (11 445 mm)	37 ft. 9 in. (11 502 mm)
Operating Weight	27,489 lb. (12 469 kg)	27,703 lb. (12 566 kg)	27,149 lb. (12 315 kg)	27,260 lb. (12 365 kg)

Loader operating information is based on machine with standard equipment; cab; rear cast bumper/counterweight; 20.5R25 tires; ROPS cab; 175-lb. (79 kg) operator; and full fuel tank. This information is affected by tire size, ballast, and different attachments.

Adjustments to Operating Weights for Standard Z-Bar with Pin-On-Type Buckets or Quick-Coupler and Hook-On-Type Buckets

Adjustments to operating weights and tipping loads for 3.0-cu.-yd. (2.3 m³) general-purpose bucket with bolt-on cutting edge

Add (+) or deduct (-) lb. (kg) as indicated for	<i>Operating Weight</i>	<i>Tipping Load, Straight</i>	<i>Tipping Load, 40-Degree Full Turn, SAE</i>
loaders with three-piece rims and			
20.5R25 L-3 tires	0 lb. (0 kg)	0 lb. (0 kg)	0 lb. (0 kg)
20.5R25 L-2 tires	- 228 lb. (- 104 kg)	- 154 lb. (- 70 kg)	- 133 lb. (- 60 kg)
20.5-25 L-2 tires	- 548 lb. (- 249 kg)	- 368 lb. (- 167 kg)	- 318 lb. (- 144 kg)
20.5-25 L-3 tires	- 416 lb. (- 189 kg)	- 279 lb. (- 127 kg)	- 162 lb. (- 74 kg)
600/65 R 25 L-3 tires**	+ 676 lb. (+ 307 kg)	+ 453 lb. (+ 206 kg)	+ 393 lb. (+ 178 kg)
23.1-26 Logger*	+ 44 lb. (+ 20 kg)	+ 30 lb. (+ 13.4 kg)	+ 26 lb. (+ 12 kg)
CaCl ₂ in 20.5-25 rear tires	+ 1,821 lb. (+ 826 kg)	+ 2,440 lb. (+ 1107 kg)	+ 2,112 lb. (+ 958 kg)
Optional rear cast bumper/counterweight (removed)	N/A	N/A	N/A

*Equipped with one-piece rims.

**CaCl₂ not recommended with 600/65R25 tires.

Standard Z-Bar Information with Quick-Coupler and Bucket

	<i>General Purpose (Wide) w/Bolt-On Edge</i>	<i>General Purpose w/Bolt-On Edge</i>
Bucket Type/Size		
Capacity, Heaped SAE	3.0 cu. yd. (2.3 m ³)	2.5 cu. yd. (1.9 m ³)
Capacity, Struck SAE	2.6 cu. yd. (2.0 m ³)	2.1 cu. yd. (1.6 m ³)
Bucket Weight with Coupler	3,206 lb. (1454 kg)	2,879 lb. (1306 kg)
Bucket Width	105.9 in. (2690 mm)	100.4 in. (2550 mm)
Breakout Force, SAE J732C	19,039 lb. (8636 kg)	18,937 lb. (8590 kg)
Tipping Load, Straight	18,163 lb. (8237 kg)	20,741 lb. (9408 kg)
Tipping Load, 40-Degree Full Turn, SAE	15,314 lb. (6945 kg)	17,548 lb. (7960 kg)
Reach, 45-Degree Dump, 7-ft. (2.13 m)		
Clearance	59.0 in. (1499 mm)	61.4 in. (1560 mm)
Reach, 45-Degree Dump, Full Height	40.3 in. (1099 mm)	43.7 in. (1109 mm)
Dump Clearance, 45 Degree, Full Height	103.6 in. (2632 mm)	107.0 in. (2718 mm)
Overall Length, Bucket on Ground	24 ft. 10 in. (7581 mm)	23 ft. 1 in. (7475 mm)
Loader Clearance Circle, Bucket In Carry		
Position	37 ft. 10 in. (11 575 mm)	38 ft. 3 in. (11 669 mm)
Operating Weight	28,299 lb. (12 834 kg)	27,967 lb. (12 686 kg)

Loader operating information is based on machine with standard equipment; cab; rear cast bumper/counterweight; 20.5R25 tires; ROPS cab; 175-lb. (79 kg) operator; and full fuel tank. This information is affected by tire size, ballast, and different attachments.

Standard Z-Bar Information with

Quick-Coupler and Construction Fork 544J

Tine Length	48 in. (1220 mm)	60 in. (1525 mm)
Overall Length	25 ft. 7 in. (7802 mm)	26 ft. 7 in. (8106 mm)
Tipping Load, Straight (fork level, load centered forward 24 in. [610 mm] on 48-in. [1220 mm] tine and 30 in. [762 mm] on 60-in. [1525 mm] tine)	14,859 lb. (6740 kg)	14,002 lb. (6351 kg)
Tipping Load, 40-Degree Full Turn (fork level, load centered forward 24 in. [610 mm] on 48-in. [1220 mm] tine and 30 in. [762 mm] on 60-in. [1525 mm] tine)	12,632 lb. (5730 kg)	11,887 lb. (5392 kg)
Operating Weight	27,097 lb. (12 289 kg)	27,199 lb. (12 335 kg)

High-Lift Z-Bar Information with Pin-On-Type Bucket

Bucket Type/Size	Narrow General Purpose w/Bolt-On Edge	Wide General Purpose w/Bolt-On Edge	General Purpose w/Bolt-On Edge
Capacity, Heaped SAE	3.0 cu. yd. (2.3 m ³)	3.0 cu. yd. (2.3 m ³)	2.5 cu. yd. (1.9 m ³)
Capacity, Struck SAE	2.6 cu. yd. (2.0 m ³)	2.6 cu. yd. (2.0 m ³)	2.1 cu. yd. (1.6 m ³)
Bucket Weight	2,400 lb. (1089 kg)	2,396 lb. (1087 kg)	2,061 lb. (935 kg)
Bucket Width	100.4 in. (2550 mm)	105.9 in. (2690 mm)	100.4 in. (2550 mm)
Breakout Force, SAE J732C	20,939 lb. (9498 kg)	22,394 lb. (10 158 kg)	24,671 lb. (11 191 kg)
Tipping Load, Straight	18,816 lb. (8535 kg)	18,713 lb. (8488 kg)	19,380 lb. (8791 kg)
Tipping Load, 40-Degree Full Turn, SAE	15,928 lb. (7225 kg)	15,815 lb. (7174 kg)	16,455 lb. (7464 kg)
Reach, 45-Degree Dump, 7-ft. (2.13 m) Clearance	70.0 in. (1779 mm)	68.7 in. (1744 mm)	67.1 in. (1705 mm)
Reach, 45-Degree Dump, Full Height	39.3 in. (999 mm)	37.0 in. (941 mm)	34.5 in. (876 mm)
Dump Clearance, 45 Degree, Full Height	123.6 in. (3139 mm)	125.6 in. (3189 mm)	128.0 in. (3249 mm)
Overall Length, Bucket on Ground	25 ft. 3 in. (7689 mm)	24 ft. 11 in. (7612 mm)	24 ft. 8 in. (7516 mm)
Loader Clearance Circle, Bucket In Carry Position	38 ft. 11 in. (11 865 mm)	39 ft. 2 in. (11 942 mm)	38 ft. 7 in. (11 751 mm)
Operating Weight	27,641 lb. (12 538 kg)	27,855 lb. (12 635 kg)	27,302 lb. (12 384 kg)

Loader operating information is based on machine with standard equipment; cab; rear cast bumper/counterweight; 20.5R25 tires; ROPS cab; 175-lb. (79 kg) operator; and full fuel tank. This information is affected by tire size, ballast, and different attachments.

Adjustments to Operating Weights for High-Lift Z-Bar with Pin-On-Type Buckets or Quick-Coupler and Hook-On-Type Buckets

Adjustments to operating weights and tipping loads for 3.0-cu.-yd. (2.3 m³) general-purpose bucket with bolt-on cutting edge

Add (+) or deduct (-) lb. (kg) as indicated for	Operating Weight	Tipping Load, Straight	Tipping Load, 40-Degree Full Turn, SAE
loaders with three-piece rims and 20.5R25 L-3 tires	0 lb. (0 kg)	0 lb. (0 kg)	0 lb. (0 kg)
20.5R25 L-2 tires	- 228 lb. (- 104 kg)	- 139 lb. (- 63 kg)	- 120 lb. (- 55 kg)
20.5-25 L-2 tires	- 548 lb. (- 249 kg)	- 332 lb. (- 150 kg)	- 287 lb. (- 130 kg)
20.5-25 L-3 tires	- 416 lb. (- 189 kg)	- 233 lb. (- 106 kg)	- 219 lb. (- 99 kg)
600/65R25 L-3 tires**	+ 676 lb. (+ 307 kg)	+ 409 lb. (+ 186 kg)	+ 355 lb. (+ 161 kg)
23.1-26 Logger*	+ 44 lb. (+ 20 kg)	+ 27 lb. (+ 12 kg)	+ 23 lb. (+ 11 kg)
CaCl ₂ in 20.5-25 rear tires	+ 1,821 lb. (+ 826 kg)	+ 2,203 lb. (+ 999 kg)	+ 1,911 lb. (+ 867 kg)
Optional rear cast bumper/counterweight (removed)	N/A	N/A	N/A

*Equipped with one-piece rims.

**CaCl₂ not recommended with 600/65R25 tires.

High-Lift Z-Bar Information with Quick-Coupler and Bucket

544J

Bucket Type/Size	General Purpose w/Bolt-On Edge	General Purpose w/Bolt-On Edge
Capacity, Heaped SAE	3.0 cu. yd. (2.3 m ³)	2.5 cu. yd. (1.9 m ³)
Capacity, Struck SAE	2.6 cu. yd. (2.0 m ³)	2.1 cu. yd. (1.6 m ³)
Bucket Weight with Coupler	3,595 lb. (1631 kg)	2,879 lb. (1306 kg)
Bucket Width	105.9 in. (2690 mm)	100.4 in. (2550 mm)
Breakout Force, SAE J732C	17,557 lb. (7964 kg)	18,104 lb. (8212 kg)
Tipping Load, Straight	16,964 lb. (7695 kg)	17,687 lb. (8023 kg)
Tipping Load, 40-Degree Full Turn, SAE	14,202 lb. (6442 kg)	14,905 lb. (6761 kg)
Reach, 45-Degree Dump, 7-ft. (2.13 m)		
Clearance	70.5 in. (1790 mm)	72.7 in. (1846 mm)
Reach, 45-Degree Dump, Full Height	43.0 in. (1092 mm)	43.4 in. (1102 mm)
Dump Clearance, 45 Degree, Full Height	117.2 in. (2977 mm)	120.6 in. (3063 mm)
Overall Length, Bucket on Ground	25 ft. 11 in. (7905 mm)	25 ft. 7 in. (7807 mm)
Loader Clearance Circle, Bucket In Carry		
Position	39 ft. 10 in. (12 151 mm)	39 ft. 4 in. (12 002 mm)
Operating Weight	28,836 lb. (13 080 kg)	28,122 lb. (12 756 kg)

Loader operating information is based on machine with standard equipment; cab; rear cast bumper/counterweight; 20.5R25 tires; ROPS cab; 175-lb. (79 kg) operator; and full fuel tank. This information is affected by tire size, ballast, and different attachments.

High-Lift Z-Bar Information with Quick-Coupler and Construction Fork

Tine Length	48 in. (1220 mm)	60 in. (1525 mm)
Overall Length	26 ft. 8 in. (8139 mm)	27 ft. 8 in. (8442 mm)
Tipping Load, Straight (fork level, load centered forward 24 in. [610 mm] on 48-in. [1220 mm] tine and 30 in. [762 mm] on 60-in. [1525 mm] tine)	13,379 lb. (6069 kg)	12,651 lb. (5739 kg)
Tipping Load, 40-Degree Full Turn (fork level, load centered forward 24 in. [610 mm] on 48-in. [1220 mm] tine and 30 in. [762 mm] on 60-in. [1525 mm] tine)	11,345 lb. (5146 kg)	10,711 lb. (4858 kg)
Operating Weight	27,249 lb. (12 358 kg)	27,351 lb. (12 404 kg)

Standard Z-Bar Pin-On Bucket Selection Guide*

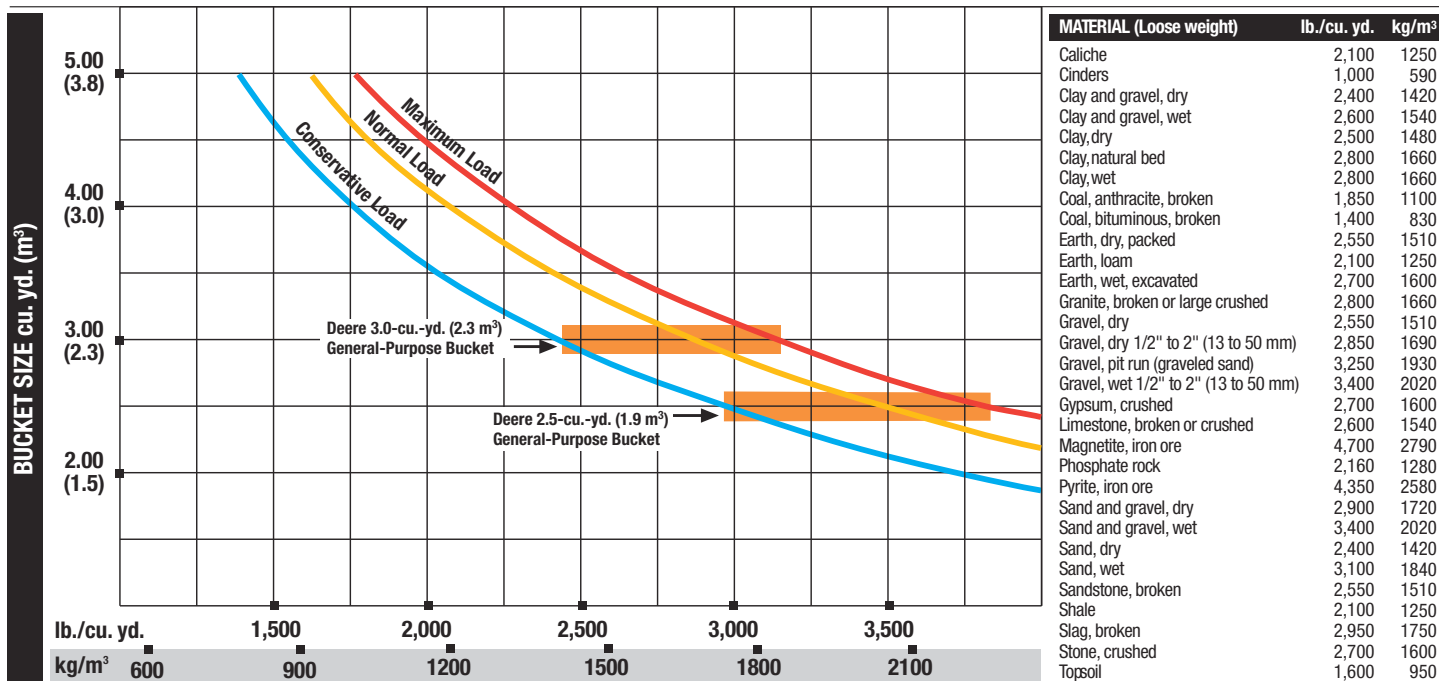

* This guide, representing bucket sizes not necessarily manufactured by Deere, will help you in selecting proper bucket size for material density, loader configuration, and operating conditions. Optimum bucket size is determined after adding or subtracting all tipping load changes due to optional equipment. The "conservative load" line on this guide is recommended when operating in conditions such as soft ground and unlevel surfaces. The "maximum load" condition on this guide is sometimes utilized when operating on firm ground and level surfaces.

Specifications

Engine 624J

Type	John Deere PowerTech 6068H; certified to EPA Tier 2 emissions
Cylinders	6
Valves Per Cylinder	4
Displacement	414 cu. in. (6.8 L)
Net Peak Power	180 hp (129 kW) @ 1,800 rpm
Net Rated Power	165 hp (119 kW) @ 2,200 rpm
Net Peak Torque	605 lb.-ft. (810 Nm) @ 1,000 rpm
Net Torque Rise	54%
Net Power Bulge	9%
Fuel System	high-pressure common rail
Lube System	full-flow spin-on filter and integral cooler
Aspiration	turbocharged, charge air cooled
Air Cleaner	dual element dry type, restriction indicator in cab monitor for service
Fan Drive	hydraulically driven, proportionally controlled, fan aft of coolers
Electrical System	24 volt with 80-amp alternator
Batteries (two 12 volt)	950 CCA

Transmission

Type	countershaft-type power shift	
Torque Converter	single stage, single phase	
Shift Control	electronically modulated, adaptive, load and speed dependent	
Operator Interface	steering-column or joystick-mounted F-N-R and gear-select lever, kick-down button on hydraulic lever	
Shift Modes	auto/manual, auto to 1st or 2nd, kick down or kick up/down, three clutch cutoff settings adjustable on switch pad	
Travel Speeds*	<i>Forward</i>	<i>Reverse</i>
Gear 1	4.5 mph (7.2 km/h)	4.7 mph (7.5 km/h)
Gear 2	7.7 mph (12.4 km/h)	8.1 mph (13.1 km/h)
Gear 3	15.2 mph (24.5 km/h)	16.0 mph (25.8 km/h)
Gear 4	24.6 mph (39.5 km/h)	

*Equipped with 20.5-25 tires.

Axles/Brakes

Final Drives	heavy-duty inboard planetary
Differentials*	hydraulic locking front, conventional rear — standard; dual locking front and rear — optional
Rear Axle Oscillation, Stop to Stop*	24 deg.
Brakes (conform to SAE J1473, ISO3450)	
Service Brakes	hydraulically actuated, inboard, carrier mounted, pressure oil cooled, self adjusting, multi-disc
Parking Brake	automatic spring applied, hydraulically released, oil cooled, multi-disc

*Equipped with 20.5-25 tires.

Tires

Choice of (with three-piece rims)	Tread Width	Width Over Tires	Change In Vertical Height
20.5R25 L-3	80.7 in. (2050 mm)	101.6 in. (2582 mm)	0 in. (0 mm)
20.5R25 L-2	80.7 in. (2050 mm)	101.6 in. (2582 mm)	- 0.83 in. (- 21 mm)
20.5-25 L-2	80.7 in. (2050 mm)	101.7 in. (2583 mm)	- 0.27 in. (- 7 mm)
20.5-25 L-3	80.7 in. (2050 mm)	101.9 in. (2588 mm)	- 0.27 in. (- 7 mm)
600/65R25 L-3	80.7 in. (2050 mm)	104.1 in. (2644 mm)	- 0.83 in. (- 21 mm)
28L-26 Logger*	89.4 in. (2272 mm)	117.6 in. (2986 mm)	+ 3.1 in. (+ 79 mm)

*Equipped with one-piece rims.

Refill Capacities (U.S.)

Fuel Tank (with ground-level fueling)	92 gal. (348 L)
Cooling System	23 qt. (22 L)
Engine Lubrication, Including Full-Flow Spin-On Filter	25 qt. (24 L)
Powershift Transmission, Including Filter	24 qt. (23 L)

Differential (each axle)	
Front	26 qt. (24.5 L)
Rear	21 qt. (20 L)
Loader Hydraulic Reservoir and Filters	31.5 gal. (119 L)
Wet-Disc Parking Brake	10 oz. (0.3 L)

Hydraulic System/Steering

Pump (loader and steering)	variable-displacement, axial-piston pump; closed-center, pressure-compensating system	
Maximum Flow @ 2,350 rpm	58 gpm (220 L/m) @ 1,000 psi (6895 kPa)	
Pressure	loader and steering relief 3,600 psi (24 850 kPa)	
Loader Controls	two-function valve; single- or dual-lever controls; control lever lockout feature; optional third- and fourth-function valve with auxiliary lever	
Steering (conforms to SAE J1511)		
Type	power, fully hydraulic	
Pressure	3,600 psi (24 850 kPa) relief	
Articulation Angle	80-degree arc (40 degrees each direction)	
Hydraulic Cycle Times	<i>Standard Z-Bar</i>	<i>High-Lift Z-Bar</i>
Raise	5.9 sec.	5.9 sec.
Dump	1.3 sec.	1.3 sec.
Lower	2.7 sec. (float down) / 3.3 sec. (power down)	2.7 sec. (float down) / 3.3 sec. (power down)
Total	9.9 sec.	9.9 sec.
Maximum Lift Capacity (with 3.0-cu.-yd. [2.3 m ³] bucket with bolt-on edge)		
Lift at Ground Level	30,958 lb. (14 040 kg)	29,190 lb. (12 238 kg)
Lift at Maximum Height	17,305 lb. (7848 kg)	15,812 lb. (7171 kg)
Turning Radius (measured to centerline of outside tire)	17 ft. 0 in. (5187 mm)	17 ft. 0 in. (5187 mm)

Dimensions with Pin-On Bucket

	<i>Standard Z-Bar</i>	<i>High-Lift Z-Bar</i>
A Height to Top of Cab and Canopy	10 ft. 10.6 in. (3317 mm)	10 ft. 10.6 in. (3317 mm)
B Height to Top of Exhaust	10 ft. 10 in. (3303 mm)	10 ft. 10 in. (3303 mm)
C Ground Clearance	17.1 in. (435.6 mm)	17.1 in. (435.6 mm)
D Length from Centerline to Front Axle	59.65 in. (1515 mm)	59.65 in. (1515 mm)
E Wheelbase	119.3 in. (3030 mm)	119.3 in. (3030 mm)
F Dump Clearance	(see page 29)	(see page 30)
G Height to Hinge Pin, Fully Raised	13 ft. 0 in. (3966 mm)	14 ft. 3 in. (4332 mm)
H Dump Reach	(see page 29)	(see page 30)
I Maximum Digging Depth	3.5 in. (88 mm)	7.4 in. (188 mm)
J Overall Length	(see page 29)	(see page 30)
K Maximum Rollback at Ground Level	40 deg.	40 deg.
L Maximum Rollback, Boom Fully Raised	55 deg.	55 deg.
M Maximum Bucket Angle, Fully Raised	50 deg.	50 deg.

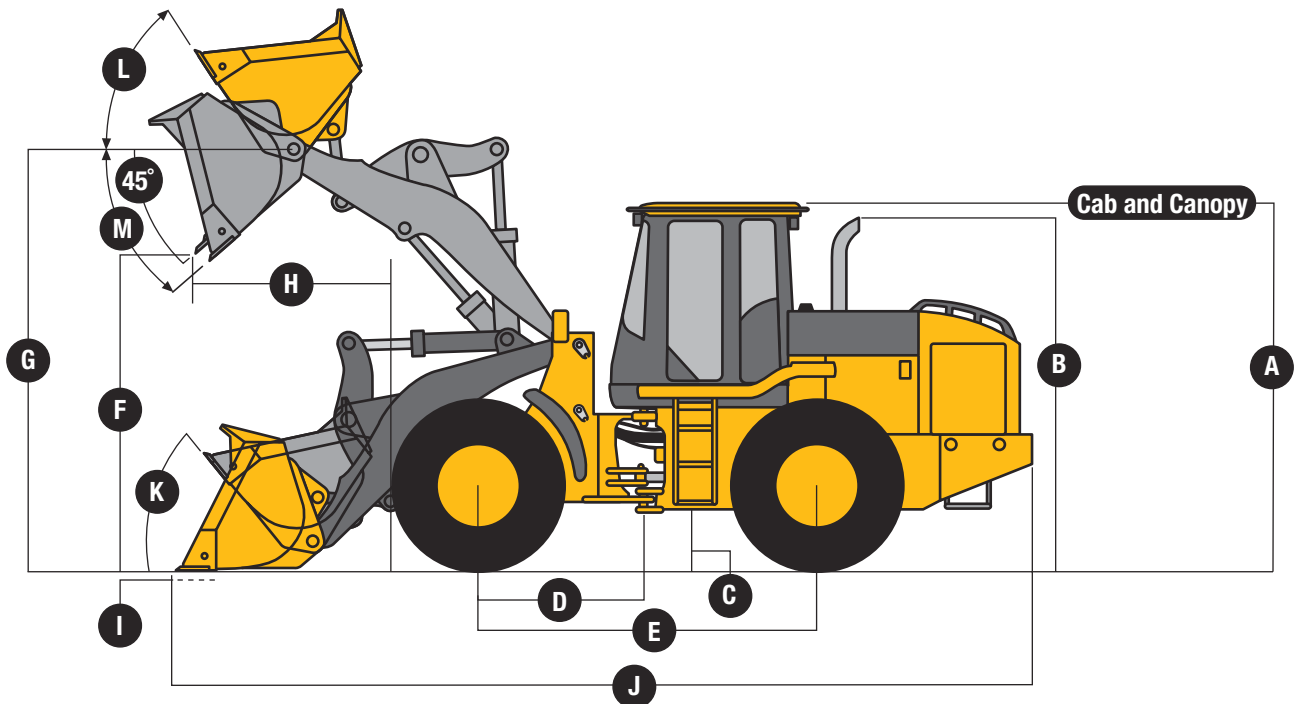

Dimensions with Quick-Coupler and Bucket

	624J <i>Standard Z-Bar</i>	<i>High-Lift Z-Bar</i> (see page 31)
A Dump Clearance	(see page 29)	(see page 31)
B Dump Reach	(see page 29)	(see page 31)
C Maximum Digging Depth	6.5 in. (164 mm)	10.5 in. (266 mm)
D Height to Hinge Pin, Fully Raised	13 ft. 0 in. (3966 mm)	14 ft. 3 in. (4332 mm)
E Overall Length	(see page 29)	(see page 31)
F Maximum Rollback, Boom Fully Raised	55 deg.	49 deg.
G Maximum Bucket Discharge Angle, Fully Raised	50 deg.	46 deg.
H Maximum Rollback at Ground Level	42 deg.	42 deg.

624J LOADER WITH QUICK-COUPLER AND BUCKET

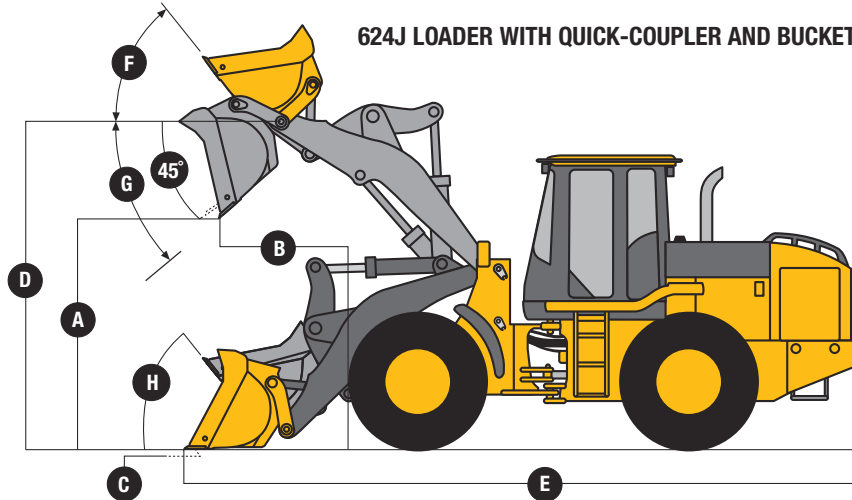

Dimensions with Quick-Coupler and Construction Fork

	624J <i>Standard Z-Bar</i>	<i>High-Lift Z-Bar</i> (see page 31)
A Reach, Fully Raised	2 ft. 5 in. (742 mm)	2 ft. 9 in. (828 mm)
B Fork Height, Fully Raised	12 ft. 2 in. (3704 mm)	13 ft. 4 in. (4070 mm)
C Maximum Reach, Fork Level	5 ft. 2 in. (1579 mm)	6 ft. 3 in. (1910 mm)
D Fork Height, Maximum Reach	5 ft. 9 in. (1748 mm)	5 ft. 9 in. (1747 mm)
E Reach, Ground Level	3 ft. 1 in. (938 mm)	4 ft. 6 in. (1357 mm)
F Depth Below Ground	1.8 in. (45 mm)	5.8 in. (146 mm)
G Tine Length	(see page 30)	(see page 31)
H Overall Length	(see page 30)	(see page 31)

624J LOADER WITH QUICK-COUPLER AND CONSTRUCTION FORK

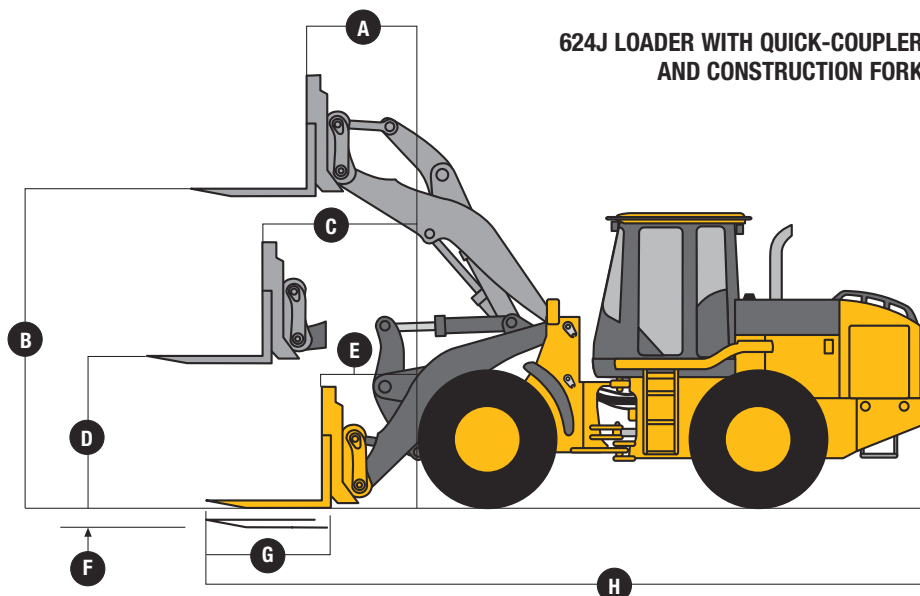

**Standard Z-Bar Information
with Pin-On-Type Bucket**

624J

	<i>General Purpose w/Bolt-On Edge</i>	<i>General Purpose w/Bolt-On Edge</i>	<i>General Purpose w/ Teeth and Segments</i>
Bucket Type/Size			
Capacity, Heaped SAE	3.5 cu. yd. (2.7 m ³)	3.0 cu. yd. (2.3 m ³)	3.0 cu. yd. (2.3 m ³)
Capacity, Struck SAE	3.0 cu. yd. (2.3 m ³)	2.5 cu. yd. (1.9 m ³)	2.5 cu. yd. (1.9 m ³)
Bucket Weight	2,630 lb. (1193 kg)	2,460 lb. (1116 kg)	2,572 lb. (1167 kg)
Bucket Width	105.9 in. (2690 mm)	105.9 in. (2690 mm)	105.9 in. (2690 mm)
Breakout Force, SAE J732C	28,483 lb. (12 920 kg)	31,526 lb. (14 300 kg)	27,709 lb. (12 569 kg)
Tipping Load, Straight	25,639 lb. (11 630 kg)	26,036 lb. (11 810 kg)	25,930 lb. (11 762 kg)
Tipping Load, 40-Degree Full Turn, SAE	21,854 lb. (9913 kg)	22,213 lb. (10 076 kg)	22,110 lb. (10 029 kg)
Reach, 45-Degree Dump, 7-ft. (2.13 m)			
Clearance	62.4 in. (1585 mm)	60.8 in. (1543 mm)	63.5 in. (1614 mm)
Reach, 45-Degree Dump, Full Height	40.6 in. (1031 mm)	37.5 in. (952 mm)	42.0 in. (1068 mm)
Dump Clearance, 45 Degree, Full Height	113 in. (2885 mm)	116.7 in. (2964 mm)	112.9 in. (2868 mm)
Overall Length, Bucket on Ground	24 ft. 10 in. (7572 mm)	24 ft. 6 in. (7452 mm)	24 ft. 11 in. (7603 mm)
Loader Clearance Circle, Bucket In Carry			
Position	39 ft. 8 in. (12 076 mm)	39 ft. 5 in. (12 008 mm)	39 ft. 8 in. (12 095 mm)
Operating Weight	31,691 lb. (14 375 kg)	31,522 lb. (14 298 kg)	31,634 lb. (14 349 kg)

Loader operating information is based on machine with standard equipment; cab; rear cast bumper/counterweight; 20.5R25 tires; ROPS cab; 175-lb. (79 kg) operator; and full fuel tank. This information is affected by tire size, ballast, and different attachments.

Adjustments to Operating Weights for Standard Z-Bar with Pin-On-Type Buckets or Quick-Coupler and Hook-On-Type Buckets

Adjustments to operating weights and tipping loads for 3.5-cu.-yd. (2.7 m³) general-purpose bucket with bolt-on cutting edge

Add (+) or deduct (-) lb. (kg) as indicated for	<i>Operating Weight</i>	<i>Tipping Load, Straight</i>	<i>Tipping Load, 40-Degree Full Turn, SAE</i>
loaders with three-piece rims and			
20.5 R 25 L-3 tires	0 lb. (0 kg)	0 lb. (0 kg)	0 lb. (0 kg)
20.5 R 25 L-2 tires	- 228 lb. (- 104 kg)	- 346 lb. (- 157 kg)	- 136 lb. (- 62 kg)
20.5-25 L-2 tires	- 548 lb. (- 249 kg)	- 377 lb. (- 171 kg)	- 325 lb. (- 147 kg)
20.5-25 L-3 tires	- 416 lb. (- 189 kg)	- 286 lb. (- 130 kg)	- 247 lb. (- 112 kg)
600/65R25 L-3 tires**	+ 676 lb. (+ 307 kg)	+ 465 lb. (+ 211 kg)	+ 401 lb. (+ 182 kg)
28L-26 Logger*	+ 835 lb. (+ 380 kg)	+ 576 lb. (+ 261 kg)	+ 497 lb. (+ 225 kg)
CaCl ₂ in 20.5-25 rear tires	+ 1,821 lb. (+ 826 kg)	+ 2,502 lb. (+ 1135 kg)	+ 2,161 lb. (+ 980 kg)
Optional rear cast bumper/counterweight (removed)	N/A	N/A	N/A

*Equipped with one-piece rims.

**CaCl₂ not recommended with 600/65R25 tires.

Standard Z-Bar Information with Quick-Coupler and Bucket

	<i>General Purpose w/Bolt-On Edge</i>	<i>General Purpose w/Bolt-On Edge</i>
Bucket Type/Size		
Capacity, Heaped SAE	3.5 cu. yd. (2.7 m ³)	3.0 cu. yd. (2.3 m ³)
Capacity, Struck SAE	3.0 cu. yd. (2.3 m ³)	2.7 cu. yd. (2.1 m ³)
Bucket Weight with Coupler	3,522 lb. (1598 kg)	3,348 lb. (1519 kg)
Bucket Width	105.9 in. (2690 mm)	105.9 in. (2690 mm)
Breakout Force, SAE J732C	23,455 lb. (10 637 kg)	25,633 lb. (11 625 kg)
Tipping Load, Straight	23,882 lb. (10 831 kg)	24,286 lb. (11 014 kg)
Tipping Load, 40-Degree Full Turn, SAE	20,237 lb. (9178 kg)	20,606 lb. (9345 kg)
Reach, 45-Degree Dump, 7-ft. (2.13 m)		
Clearance	63.0 in. (1600 mm)	61.7 in. (1568 mm)
Reach, 45-Degree Dump, Full Height	45.7 in. (1161 mm)	42.6 in. (1081 mm)
Dump Clearance, 45 Degree, Full Height	105.4 in. (2678 mm)	108.6 in. (2759 mm)
Overall Length, Bucket on Ground	25 ft. 10 in. (7864 mm)	25 ft. 5 in. (7744 mm)
Loader Clearance Circle, Bucket In Carry		
Position	40 ft. 3 in. (12 258 mm)	40 ft. 0 in. (12 183 mm)
Operating Weight	32,608 lb. (14 788 kg)	32,416 lb. (14 701 kg)

Loader operating information is based on machine with standard equipment; cab; rear cast bumper/counterweight; 20.5R25 tires; ROPS cab; 175-lb. (79 kg) operator; and full fuel tank. This information is affected by tire size, ballast, and different attachments.

Standard Z-Bar Information with

Quick-Coupler and Construction Fork 624J

Tine Length	48 in. (1220 mm)	60 in. (1525 mm)
Overall Length	26 ft. 2 in. (7967 mm)	27 ft. 2 in. (8270 mm)
Tipping Load, Straight (fork level, load centered forward 24 in. [610 mm] on 48-in. [1220 mm] tine and 30 in. [762 mm] on 60-in. [1525 mm] tine)	17,324 lb. (7858 kg)	16,357 lb. (7419 kg)
Tipping Load, 40-Degree Full Turn (fork level, load centered forward 24 in. [610 mm] on 48-in. [1220 mm] tine and 30 in. [762 mm] on 60-in. [1525 mm] tine)	14,784 lb. (6706 kg)	13,942 lb. (6324 kg)
Operating Weight	31,227 lb. (14 162 kg)	31,331 lb. (14 209 kg)

High-Lift Z-Bar Information with Pin-On-Type Bucket

Bucket Type/Size	General Purpose w/Bolt-On Edge	General Purpose w/Bolt-On Edge
Capacity, Heaped SAE	3.5 cu. yd. (2.7 m ³)	3.0 cu. yd. (2.3 m ³)
Capacity, Struck SAE	3.0 cu. yd. (2.3 m ³)	2.7 cu. yd. (2.1 m ³)
Bucket Weight	2,630 lb. (1193 kg)	2,460 lb. (1116 kg)
Bucket Width	105.9 in. (2690 mm)	105.9 in. (2690 mm)
Breakout Force, SAE J732C	25,884 lb. (11 741 kg)	28,657 lb. (12 999 kg)
Tipping Load, Straight	21,193 lb. (9613 kg)	21,543 lb. (9772 kg)
Tipping Load, 40-Degree Full Turn, SAE	17,998 lb. (8164 kg)	18,320 lb. (8310 kg)
Reach, 45-Degree Dump, 7-ft. (2.13 m)		
Clearance	76.4 in. (1941 mm)	74.9 in. (1903 mm)
Reach, 45-Degree Dump, Full Height	44.0 in. (1117 mm)	40.9 in. (1039 mm)
Dump Clearance, 45 Degree, Full Height	128.0 in. (3251 mm)	131.1 in. (3330 mm)
Overall Length, Bucket on Ground	26 ft. 2 in. (7984 mm)	25 ft. 10 in. (7866 mm)
Loader Clearance Circle, Bucket In Carry		
Position	40 ft. 10 in. (12 452 mm)	40 ft. 7 in. (12 375 mm)
Operating Weight	31,885 lb. (14 463 kg)	31,715 lb. (14 386 kg)

Loader operating information is based on machine with standard equipment; cab; rear cast bumper/counterweight; 20.5R25 tires; ROPS cab; 175-lb. (79 kg) operator; and full fuel tank. This information is affected by tire size, ballast, and different attachments.

Adjustments to Operating Weights for High-Lift Z-Bar with Pin-On-Type Buckets or Quick-Coupler and Hook-On-Type Buckets

Adjustments to operating weights and tipping loads for 3.5-cu.-yd. (2.7 m³) general-purpose bucket with bolt-on cutting edge

Add (+) or deduct (-) lb. (kg) as indicated for

loaders with three-piece rims and	Operating Weight	Tipping Load, Straight	Tipping Load, 40-Degree Full Turn, SAE
20.5R25 L-3 tires	0 lb. (0 kg)	0 lb. (0 kg)	0 lb. (0 kg)
20.5R25 L-2 tires	- 228 lb. (- 104 kg)	- 140 lb. (- 63 kg)	- 120 lb. (- 54.6 kg)
20.5R25 L-3 tires	- 64 lb. (- 29 kg)	- 39 lb. (- 18 kg)	- 34 lb. (- 15 kg)
20.5-25 L-2 tires	- 548 lb. (- 249 kg)	- 161 lb. (- 73.2 kg)	- 288 lb. (- 131 kg)
20.5-25 L-3 tires	- 416 lb. (- 189 kg)	- 254 lb. (- 115 kg)	- 218 lb. (- 99 kg)
600/65R25 L-3 tires**	+ 676 lb. (+ 307 kg)	+ 412 lb. (+ 187 kg)	+ 355 lb. (+ 161 kg)
28L-26 Logger*	+ 835 lb. (+ 380 kg)	+ 511 lb. (+ 232 kg)	+ 440 lb. (+ 200 kg)
CaCl ₂ in 20.5-25 rear tires	+ 1,821 lb. (+ 826 kg)	+ 2,221 lb. (+ 1007 kg)	+ 1,912 lb. (+ 867 kg)
Optional rear cast bumper/counterweight (removed)	N/A	N/A	N/A

*Equipped with one-piece rims.

**CaCl₂ not recommended with 600/65R25 tires.

High-Lift Z-Bar Information with Quick-Coupler and Bucket

624J

Bucket Type/Size	General Purpose w/Bolt-On Edge	General Purpose w/Bolt-On Edge
Capacity, Heaped SAE	3.5 cu. yd. (2.7 m ³)	3.0 cu. yd. (2.3 m ³)
Capacity, Struck SAE	3.0 cu. yd. (2.3 m ³)	2.5 cu. yd. (1.9 m ³)
Bucket Weight with Coupler	3,523 lb. (1598 kg)	3,348 lb. (1519 kg)
Bucket Width	105.9 in. (2690 mm)	105.9 in. (2690 mm)
Breakout Force, SAE J732C	21,358 lb. (9686 kg)	23,342 lb. (10 588 kg)
Tipping Load, Straight	19,682 lb. (8926 kg)	20,041 lb. (9089 kg)
Tipping Load, 40-Degree Full Turn, SAE	16,595 lb. (7526 kg)	16,924 lb. (7677 kg)
Reach, 45-Degree Dump, 7-ft. (2.13 m)		
Clearance	77.9 in. (1980 mm)	75.9 in. (1928 mm)
Reach, 45-Degree Dump, Full Height	49.0 in. (1247 mm)	45.6 in. (1158 mm)
Dump Clearance, 45 Degree, Full Height	119 in. (3043 mm)	122 in. (3118 mm)
Overall Length, Bucket on Ground	27 ft. 1 in. (8267 mm)	26 ft. 9 in. (8148 mm)
Loader Clearance Circle, Bucket In Carry		
Position	41 ft. 6 in. (12 652 mm)	41 ft. 3 in. (12 570 mm)
Operating Weight	32,802 lb. (14 876 kg)	32,604 lb. (14 789 kg)

Loader operating information is based on machine with standard equipment; cab; rear cast bumper/counterweight; 20.5R25 tires; ROPS cab; 175-lb. (79 kg) operator; and full fuel tank. This information is affected by tire size, ballast, and different attachments.

High-Lift Z-Bar Information with Quick-Coupler and Construction Fork

Tine Length	48 in. (1220 mm)	60 in. (1525 mm)
Overall Length	27 ft. 6 in. (8385 mm)	28 ft. 6 in. (8688 mm)
Tipping Load, Straight (fork level, load centered forward 24 in. [610 mm] on 48-in. [1220 mm] tine and 30 in. [762 mm] on 60-in. [1525 mm] tine)	15,253 lb. (6919 kg)	14,462 lb. (6560 kg)
Tipping Load, 40-Degree Full Turn (fork level, load centered forward 24 in. [610 mm] on 48-in. [1220 mm] tine and 30 in. [762 mm] on 60-in. [1525 mm] tine)	12,978 lb. (5887 kg)	12,288 lb. (5574 kg)
Operating Weight	31,423 lb. (14 251 kg)	31,525 lb. (14 297 kg)

Standard Z-Bar Pin-On Bucket Selection Guide*

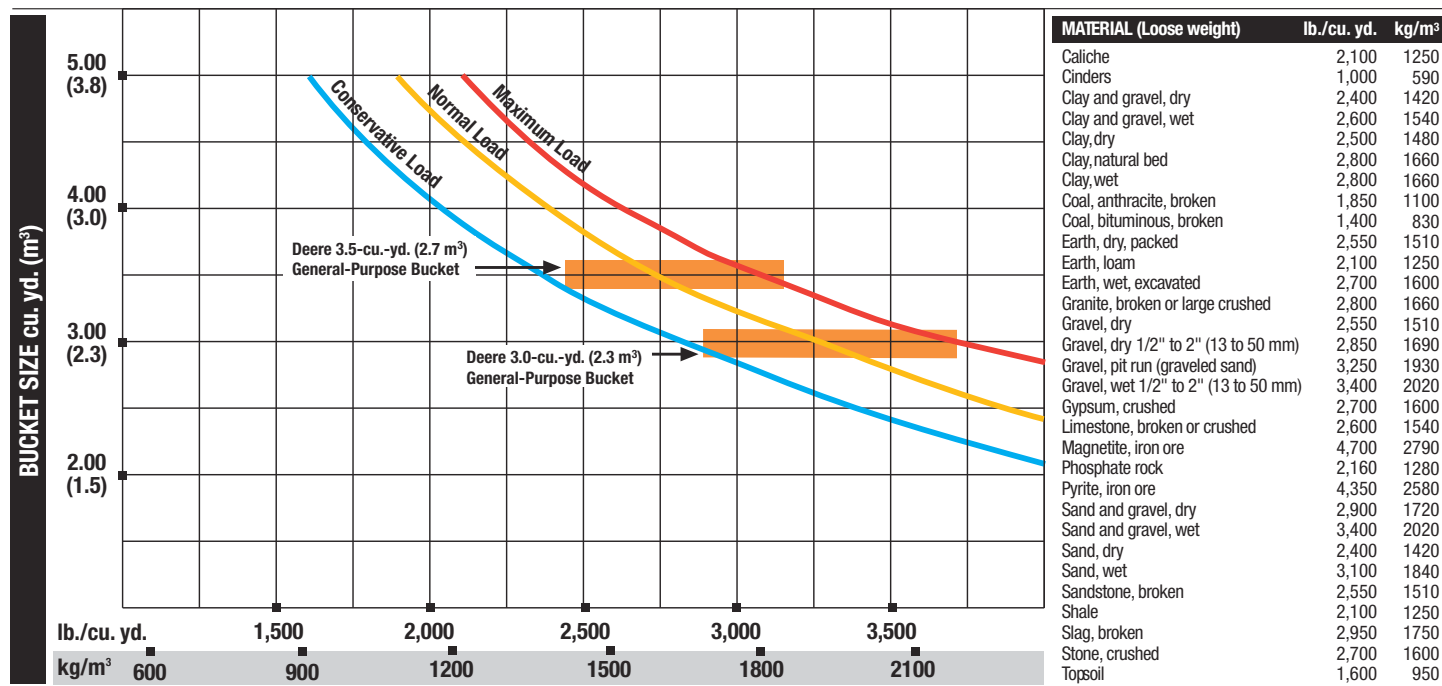

* This guide, representing bucket sizes not necessarily manufactured by Deere, will help you in selecting proper bucket size for material density, loader configuration, and operating conditions. Optimum bucket size is determined after adding or subtracting all tipping load changes due to optional equipment. The "conservative load" line on this guide is recommended when operating in conditions such as soft ground and unlevel surfaces. The "maximum load" condition on this guide is sometimes utilized when operating on firm ground and level surfaces.

444J / 544J / 624J LOADERS

Key: ● Standard equipment ▲ Optional equipment

444 544 624 Engine

- ● ● Certified to EPA Tier 2 emissions
- ● ● Wet sleeve cylinder liners
- ● ● Electronically controlled fuel system
- ● ● Automatic derating when system temperatures exceeded
- ● Monitor-selected high-altitude compensation
- ● ● Under-hood muffler with large exhaust stack
- ● ● Under-hood dual-element air cleaner with restriction sensor in cab monitor
- ● ● Underhood, pre-screened air intake
- ● ● Fuel filter/water separator
- ● ● Heavy-duty steel fuel tank guard
- ● ● 500-hour full-flow spin-on oil filter
- ● ● Polyvee drive belt with automatic tensioner
- ● ● Automatic glow plugs
- ▲ ▲ Ether start aid (required for cold starting down to -13°F [-25°C])
- ▲ ▲ Intake air heater (required for cold starting down to 0°F [-18°C])
- ▲ ▲ ▲ 110-volt engine coolant heater (required for cold starting below -13°F [-25°C])
- ▲ ▲ ▲ Centrifugal engine air pre-cleaner
- ▲ ▲ ▲ Chrome exhaust stack
- ▲ ▲ ▲ Environmentally friendly engine oil drain
- ▲ ▲ ▲ Special-application trash screens, axle seal guards, etc.*

Cooling

- ● ● Heavy-duty trash-resistant high-ambient cooling package
- ● ● Two-side access to all coolers
- ● ● Cooling system isolated from engine compartment
- ● ● Proportionally controlled (cool-on-demand), hydraulically driven, swing-out fan
- ● ● Intercooler (air/air - 6.5 fins per in.)
- ● ● Transmission oil cooler (oil/air - 6.5 fins per in.)
- ● ● Hydraulic oil cooler (oil/air - 6.5 fins per in.)
- ● ● Engine radiator (7.5 fins per in.)
- ● ● Integral engine oil cooler
- ● ● Coolant recovery tank
- ● ● Fan guard
- ▲ ▲ ▲ Axle coolers (6.5 fins per in.)
- ▲ ▲ ▲ Reversing fan drive — auto control with manual override
- ▲ ▲ ▲ Harsh-environment coolers for corrosive environments

Powertrain

- ● ● ZF torque-converter powershift transmission — 4F/3R
- ● ● Electronically controlled, adaptive, load- and speed-dependent shift modulation
- ● ● Clutch calibration engaged from cab monitor
- ● ● Clutch cutoff — thresholds set from switch pad
- ● ● Auto-shift/manual-shift modes
- ● ● Gear kickdown button in hydraulic-control lever
- ● ● Integral transmission sight gauge/fill tube
- ● ● Spring-applied, hydraulically released, oil-cooled, multi-disc park brake
- ● ● Lube-for-life U-joints
- ● ● Heavy-duty mid-board planetary final drives
- ● ● Heavy-duty inboard planetary final drives
- ● ● Front axle with hydraulic locking differential
- ▲ ▲ ▲ Front and rear axle with open differential*
- ▲ ▲ ▲ Front-axle disconnect
- ▲ ▲ ▲ Remote-axle breathers

Hydraulic System

- ● ● Pressure-compensating load-sensing hydraulic system
- ● ● In-cab adjustable automatic bucket positioner
- ● ● In-cab adjustable automatic boom height kickout control
- ● ● In-cab adjustable automatic boom return-to-carry control

444 544 624 Hydraulic System (continued)

- ● ● Reservoir sight gauge
- ● ● Spin-on hydraulic filters, vertical mounting
- ● ● Hydraulic lever lockout
- ● ● Two-function hydraulic valve with single-lever control
- ▲ ▲ ▲ Two-function hydraulic valve with two-lever fingertip controls and adjustable wristrest
- ▲ ▲ ▲ Three-function hydraulic valve with single-lever control and auxiliary lever for third function
- ▲ ▲ ▲ Three-function hydraulic valve with two-lever fingertip controls, adjustable wristrest, and auxiliary lever for third function
- ▲ ▲ ▲ Four-function hydraulic valve, with dual single-lever controls
- ▲ ▲ ▲ Hydraulic conversion kits, two-to-three- and three-to-four-function valves
- ▲ ▲ ▲ Ride control, programmable auto speed
- ▲ ▲ ▲ Hydraulic control system for quick-coupler locking pins

Electrical

- ● ● 24-volt electrical system
- ● ● Solid-state electrical power distribution system
- ● ● High-capacity batteries (2), 12 volt with 950 CCA, 200-min. rated reserve
- ● ● Master electrical disconnect switch
- ▲ ▲ ▲ Alternator, high capacity, 80 amps and 24 volts
- ▲ ▲ ▲ Alternator trash covers
- ● ● Lights (conform to SAE 99): Driving with guards / Turn signals and flashers / Stop and taillights
- ● ● LED heavy-duty taillights and turn signals
- ● ● Work lights, front (4) and rear (2)
- ● ● Horn, with push button in center of steering wheel (conforms to SAE J994, J1446)
- ● ● Reverse warning alarm (conforms to SAE J994, J1446)
- ● ● Computerized multifunction monitor
- ● ● Audible and visual warnings: Amber caution / Red stop / Analog gauges: Engine coolant temperature, transmission oil temperature, fuel level, hydraulic oil temperature, engine oil pressure / Digital instruments: Engine rpm, odometer, transmission gear indicator, speedometer, hour meter / Operator warning lights: Check engine, engine oil pressure, engine air filter restriction, battery voltage, transmission filter restriction, brake pressure, hydraulic oil filter, fasten seat belt, transmission fault, hydraulic oil temperature
- ● ● Indicator lights: Park brake / Ride control / Turn signals and warning flashers / Coupler pin disconnect / Engine preheater / Secondary steering / Work lights
- ● ● Built-in diagnostics: Fault code retrieval
- ▲ ▲ ▲ AM/FM/WB stereo radio
- ▲ ▲ ▲ AM/FM/WB stereo radio with cassette
- ▲ ▲ ▲ AM/FM/WB stereo radio with CD
- ▲ ▲ ▲ 5-amp, 12-volt convertor with one power plug
- ▲ ▲ ▲ 10-amp, 12-volt convertor with two power plugs
- ● ● Cab wired for rotating beacon
- ▲ ▲ ▲ Electrical corrosion-prevention package

Operator's Station

- ● ● Canopy (conforms to SAE J1040 APR88): ROPS/FOPS / Multiplane isolation mounted for noise/vibration reduction / Optional canopy rear window glass, for noise reduction
- ▲ ▲ ▲ Cab (conforms to SAE J1040 ARP88): ROPS/FOPS / Heater/defroster / Multiplane isolation mounted for noise/vibration reduction / Front and rear windshield washers and intermittent wipers / Tinted safety glass
- ▲ ▲ ▲ Canopy rear window
- ▲ ▲ ▲ Air conditioning
- ● ● Seat belt, 3 in. (76 mm), with retractor
- ● ● Air-suspension seat, deluxe vinyl covered with deep foam, high back, adjustable for weight-height, fore-aft position, backrest tilt, and armrest angle

*See your John Deere dealer for further information.

444 544 624 Operator's Station (continued)

- ▲ ▲ ▲ Air-suspension seat, deluxe cloth covered with deep foam, high back, adjustable for weight-height, fore-aft position, backrest tilt, and armrest angle
- ● ● Seat backrest extension
- ● ● Cup holder, personal cooler holder
- ▲ ▲ ▲ Sun visor for cab
- ● ● Storage compartment for operator's manual and other items
- ● ● Rubber floor mat
- ● ● Tilt steering column
- ● ● Steering wheel, textured with spinner knob
- ● ● Rearview mirrors, outside (2) and inside (1) (conform to SAE J985)
- ● ● Handholds and steps, ergonomically located and slip resistant (conform to SAE J185)

Loader Linkage

- ● ● Loader boom service locking bar (conforms to SAE J38)
- ● ● Z-bar loader linkage
- ▲ ▲ ▲ Power/lift linkage for visibility and parallel-lift
- ▲ ▲ ▲ High-lift Z-bar loader linkage

Buckets and Attachments

- ▲ ▲ ▲ Full line of Deere hook-on buckets with selection of bolt-on cutting edges and teeth-segmented bolt-on cutting edges*
- ▲ ▲ ▲ Full line of Deere construction utility forks for couplers
- ▲ ▲ ▲ Worksite Pro™ quick-coupler which accepts JRB-pattern attachments
- ▲ ▲ ▲ Hi-vis coupler which accepts Euro-pattern attachments
- ▲ ▲ ▲ Bolt-on fork frame guard
- ▲ ▲ ▲ Hydraulic control system for quick-coupler locking pins, includes all controls in the cab, lines, and valves

Tires

- ▲ 17.5-25 L2
- ▲ 17.5-25 L3
- ▲ 17.5R25 L2
- ▲ 17.5R25 L3
- ▲ ▲ ▲ 20.5-25 L2
- ▲ ▲ ▲ 20.5-25 L3
- ▲ ▲ ▲ 20.5R25 L2
- ▲ ▲ ▲ 20.5R25 L3
- ▲ 550/65R25 L2
- ▲ ▲ ▲ 600/65R25 L3
- ▲ 23.1-26 LS-2 Logger
- ▲ 28L-26 LS-2 Logger
- ▲ Single-piece rims
- ▲ ● ● Multi-piece rims
- ▲ ▲ ▲ Less wheels and tires
- ▲ ▲ ▲ 8-degree rear axle stops for extra-large tires and chains

Other

- ▲ ▲ ▲ Sound-suppression package
- ● ● Fenders, front
- ▲ ▲ ▲ Fenders, full-coverage front
- ▲ ▲ ▲ Fenders, full-coverage front and rear
- ▲ ▲ ▲ Close-mounted steps
- ● ● Articulation locking bar (conforms to SAE J276)
- ● ● Vandal protection, includes lockable engine enclosure and fuel fill
- ● ● Counterweight, built-in
- ● ● Front and rear tie-down points
- ● ● Drawbar, with locking pin
- ▲ ▲ ▲ Rear cast bumper/counterweight with integral drawbar
- ▲ ▲ ▲ Transmission side frame guards
- ▲ ▲ ▲ Bottom guards, front frame and transmission
- ▲ ▲ ▲ Lift eyes
- ▲ ▲ ▲ Fire extinguisher
- ▲ ▲ ▲ License plate bracket and light
- ▲ ▲ ▲ Secondary steering
- ▲ ▲ ▲ Loadrite™ weighing system



JOHN DEERE

DKAJULDR Litho in U.S.A. (06-10)

Net engine power is with standard equipment including air cleaner, exhaust system, alternator, and cooling fan, at standard conditions per SAE J1349 and DIN 70 020, using No. 2-D fuel at 35 API gravity. No derating is required up to 5,000-ft. (1525 m) altitude for the 444J and the 544J and up to 10,000-ft. (3050 m) altitude for the 624J. Gross power is without cooling fan.

Specifications and design subject to change without notice. Wherever applicable, specifications are in accordance with ISO standards. Except where otherwise noted, these specifications are based on units with standard equipment, ROPS cab, one optional rear counterweight, rear cast bumper/counterweight, 20.5R25 tires, full fuel tank, and 175-lb. (79 kg) operator.



Courtesy of Machine.Market