

550K/650K/700K CRAWLER DOZERS

69–97 kW (92–130 hp)



JOHN DEERE





We hear you loud and clear.

When customers sound off, we listen. So when our Customer Advocate Group (CAG) participants asked us to turn down the noise and turn up productivity on our 550K, 650K, and 700K Dozers, we responded with a spacious, redesigned cab that's noticeably quieter. EPA Final Tier 4 (FT4)/EU Stage IV diesel engines for work in nonattainment areas. And Eco mode for improved fuel efficiency with no loss in productivity. There's more to like in the new Dozer, such as a hydraulic-driven fan that provides efficient cooling, less noise, and conserves precious fuel. And a convenient sealed control module for fingertip control of numerous on-board features. We also include Ultimate UptimeSM as a John Deere WorksightSM in base. You get pre-delivery and follow-up inspections, plus three years of JDLinkSM Ultimate telematics, machine health, prognostics, and remote diagnostics and programming. You can work with your Deere dealer to add other uptime services that meet the needs of your operation, too.

Our FT4/Stage IV diesels meet emission regulations without sacrificing power or torque. We built on our Interim Tier 4 (IT4)/Stage IIIb solution to deliver the best combination of performance, efficiency, and reliability. This technology is simple, fluid-efficient, fully integrated, and fully supported. It employs field-proven cooled exhaust gas recirculation (EGR), easy-to-maintain high-uptime exhaust filters, and selective catalytic reduction (SCR).

Specifications	550K XLT	550K LGP
Rated Power	69 kW (92 hp)	69 kW (92 hp)
Base Weight	8908 kg (19,640 lb.)	9354 kg (20,622 lb.)
Specifications	650K XLT	650K LGP
Rated Power	78 kW (104 hp)	78 kW (104 hp)
Base Weight	9049 kg (19,949 lb.)	9514 kg (20,974 lb.)
Specifications	700K XLT	700K LGP
Rated Power	97 kW (130 hp)	97 kW (130 hp)
Base Weight	13 733 kg (30,275 lb.)	14 193 kg (31,290 lb.)



Pushes envelopes, too.

Power turns. Counter-rotating tracks. Power management. Infinitely variable travel speeds. We introduced these productivity-boosting advantages more than 35 years ago. And the K-Series is loaded with even more performance enhancements. Like Eco mode, which will help save fuel with no loss of productivity, adding more money to your bottom line. And Total Machine Control (TMC), which allows customized decelerator mode and response, forward/reverse ground speed, steering modulation, and forward/reverse speed ratios.



Eco mode maximizes fuel economy without sacrificing performance, automatically adjusting engine rpm and transmission settings based on load.

These dozers steer the same and maintain their preset speed whether working on level ground or a 2-to-1 slope. So there's never a need to cross-steer or ride a brake.

Infinitely variable range to 11 km/h (6.8 mph) allows total flexibility to match ground speed to the load. Travel can also be varied to fit specific applications, terrain conditions, or operating preferences — and even limited to maximize undercarriage life.

When you order your dozer with electro-hydraulic (EH) controls, it is grade-control ready. Our “open-architecture” design makes adding a grade-control system as easy as plugging in the components, calibrating, and going to work, whether your preference be Trimble, Leica, or a factory-installed Topcon 3D-MC² system.

1. Simply set maximum desired ground speed and the power-management system automatically maintains peak engine rpm and power efficiency without stalling or shifting.

2. Counter-rotation boosts productivity by enabling an operator to overcome heavy corner loads and quickly reposition the blade on the go. Provides space-saving spot turns, too.

3. Blade ratio and center of gravity are optimized, providing the balance needed for superior grade work. More track on the ground and an additional bottom roller give these dozers even better balance and grading ability than their predecessors.



Your silent partners.

K-Series Dozers quietly go about the business of making your operators more comfortably productive. Inside their spacious, well-appointed cabs, you can almost hear fatigue drop. With plenty of tinted glass, all-around visibility is excellent. Ergonomically designed F-N-R joystick, steering pedals, and decelerator are fully customizable through the monitor. And the sealed-switch module (SSM) allows convenient fingertip operation of keyless start and numerous other functions. You'll discover everything your operators need to get more done in a K-Series Dozer.

Standard high-back air-suspension seat and optional deluxe heated and leather-bolstered lower cushion adjust multiple ways for daylong comfort and support. Arm- and footrests also adjust.

Generous hydraulic flow and precise metering ensure powerful and quick blade response, while providing the natural "feel" that makes the most of an operator's grading ability.

Retractable seat belt, slip-resistant floor mat, convenient grab bars, neutral-start lever, and dual park-lock levers help keep the operator out of harm's way.

High-intensity halogen driving lights are standard. Or opt for the 360-deg. light package to extend your workday beyond daylight.

Cab-forward design provides a commanding view behind, below, and beyond the blade. Side and rear visibility is also unobstructed.

Optional electrohydraulic (EH) controls significantly improve blade response up to 50 percent. Blade Shake feature for Power-Angle-Tilt (PAT) blades automatically shakes off dirt at the touch of a button.

Single lever provides low-effort control of steering, forward/reverse travel, and ground speed. It's also detented so it doesn't require an operator's constant touch or attention, and employs a thumb-actuated travel-speed switch.

At just 75 dBA, the redesigned cab is noticeably quiet. Spacious and comfortable, too.



Nothing runs like a Deere, because nothing is built like it.

Designed and built with state-of-the-art tools and techniques by a quality-conscious workforce at our world-class facility in Dubuque, Iowa, K-Series Dozers are loaded with uptime-boosting features. Enhancements include a variable-speed hydraulic-driven cooling-system fan, turbo cool-down, automatic transmission protection, and available severe-duty fuel filter. These, plus traditional John Deere features such as one-piece unitized mainframes, Dura-Trax™ undercarriages, wet-sleeve engine liners, O-ring face-seal hose couplers, and isolated planetary final drives deliver the durability you demand. When you know how they're built, you'll run a Deere.

1. Closed-cell blade design and robot-welded, fabricated, box-section C-frame is strong and durable. Heavy-duty ball-and-socket joint resists material buildup for long-term grading precision.

2. Available Maximum Life Undercarriage delivers up to twice the bushing life, for extra durability in extremely abrasive conditions. If you want to further reduce maintenance and operating costs, contact your John Deere dealer about our undercarriage wear-assurance programs.

3. Available reversing hydraulic-powered fan automatically back-blows the cooler cores at preset intervals. When conditions demand more frequent cleaning, simply press a button to actuate the reversing cycle.



Courtesy of MachineMarket



Individually replaceable wet-sleeve engine-cylinder liners provide uniform engine cooling and long-term durability.

Exclusive turbo cool-down increases durability by allowing the engine to idle momentarily prior to shutting down.

Triple-reduction planetary final drives are mounted independent of the track frames, where they're effectively protected from shock loads.

Engine, hydrostatic pumps, and hydraulic pump are bolted to a subframe, forming an easy-to-remove powertrain package. It's attached to the mainframe on rubber mounts to isolate vibration and reduce noise.

Eco mode automatically adjusts engine power and transmission settings based on load while maintaining ground speed, to help optimize fuel economy. Auto-idle helps save fuel by reducing engine speed when the dozer is not moving.

Transmission temperature is constantly monitored to protect the hydrostatic system. If temps get too hot or too cold, a warning light illuminates, and the transmission and engine speed are automatically derated to prevent damage.

Heavy-duty high-pressure hoses connect the pumps and motors that form the drivetrain. O-ring face-seal couplings virtually eliminate leaks.

Declare open season on operating costs.

We're pretty open-minded when it comes to keeping uptime up and daily operating costs down. Hinged side shields reveal convenient same-side daily service points, and the front grille tilts forward, simplifying cooler-core cleanout. Other periodic tasks such as fluid and filter changes are quick and convenient, and service intervals have been extended so you can work longer between changes. With our K-Series Dozers, you'll spend less effort and expense getting ready for work — and more time getting work done.

After an operator-determined period of inactivity, auto-shutdown turns off the engine, preserving precious fuel and warranty hours.

Available quick fluid-evacuation system helps speed servicing. 500-hour engine oil and 2,000-hour transmission and hydraulic fluid intervals decrease downtime and expense.

1. Exhaust filter operation and status are indicated with icons and on-screen displays. The diagnostic monitor also provides easy-to-understand messages that help speed troubleshooting.
2. Fluid-sample ports simplify preventive maintenance. Engine, hydraulics, and transmission utilize a common oil, further simplifying service.
3. Vertical filters allow quick, no-spill changes. Available severe-duty fuel filter provides an extra degree of filtration. Includes a heated water separator for cold-weather service.





Hinged engine side shields swing open wide and the front grille tilts forward for convenient access to dipsticks, fill tubes, batteries, master electrical shutoff, the backside of the cooler, and engine, transmission, and hydraulic filters.

John Deere WorkSight is an exclusive suite of telematic solutions that increases uptime while lowering operating costs. At its heart, JDLink Ultimate machine monitoring provides real-time utilization data and alerts to help you maximize productivity and efficiency while minimizing downtime. Remote diagnostics enable your dealer to read codes, record performance data, and even update software without a trip to the jobsite.

Ultimate Uptime, featuring John Deere WorkSight, is a customizable support solution available exclusively from your Deere dealer. This flexible offering maximizes equipment availability with standard John Deere WorkSight capabilities that can help prevent future downtime and speed repairs when needed. In addition to the base John Deere WorkSight features, our dealers work with you to build an uptime package that meets the specific needs of your machine, fleet, project, and business, including customized maintenance and repair agreements, onsite parts availability, extended warranties, fluid sampling, response-time guarantees, and more.

Ash-service intervals for the diesel particulate filter (DPF) are condition based, meaning the machine will notify the operator before service is required. Typically, ash service is not necessary until the first engine overhaul. Machine application, regular maintenance practices, and type of lubricating oil impact ash-service intervals.

Sealed hydraulic and hydrostatic reservoirs are separate, eliminating any possibility of cross-contamination.

550K



Engine	550K XLT / 550K LGP
Blade Type	<i>Power-Angle-Tilt (PAT)</i>
Manufacturer and Model	John Deere PowerTech™ PWS 4045
Non-Road Emission Standard	EPA Final Tier 4/EU Stage IV
Displacement	4.5L (276 cu. in.)
SAE Net Rated Power	69 kW (92 hp) at 2,200 rpm
Net Peak Torque	420 Nm (310 ft.-lb.) at 1,400 rpm
Aspiration	Turbocharged with charge-air cooler
Air Cleaner	Dual-stage dry tube with tangential unloader
Cooling	
Type	Variable-speed suction fan with optional reversing feature
Engine Coolant Rating	-37 deg. C. (-34 deg. F)
Engine Radiator	10 fins per in.
Powertrain	
Transmission	Automatic, dual-path, hydrostatic drive; load-sensing feature automatically adjusts speed and power to match changing load conditions; each individually controlled track is powered by a variable-displacement piston pump and motor combination; ground-speed selection buttons on single-lever steering and direction control; independently selectable reverse speed ratios of 100% , 115%, or 130% of forward ground speed; decelerator pedal controls ground speed to stop
System Relief Pressure	42 816 kPa (6,210 psi)
Travel Speeds	
Forward and Reverse	8.0 km/h (5.0 mph)
Maximum (optional)	9.7 km/h (6.0 mph)
Steering	Single-lever steering, direction control, and counter-rotation; full power turns and infinitely variable track speeds provide unlimited maneuverability and optimum control; hydrostatic steering eliminates steering clutches and brakes
Final Drives	Triple-reduction final drives mounted independently of track frames and dozer push frames for isolation from shock loads
Total Ratio	52.13 to 1
Drawbar Pull	
Maximum	134 kN (30,000 lb.)
At 1.9 km/h (1.2 mph)	95 kN (21,300 lb.)
At 3.2 km/h (2.0 mph)	59 kN (13,300 lb.)
Brakes	
Service	Hydrostatic (dynamic) braking stops the machine whenever the direction-control lever is moved to neutral or the decelerator is depressed to the detent
Parking	Exclusive spring-applied, hydraulically released park-brake feature engages wet, multiple-disc brakes automatically whenever the engine stops, the operator depresses the decelerator pedal to the brake position, the unit is in neutral for 3 seconds (with detected motion), or the park-lock lever is in the park position; machine cannot be driven with brake applied, minimizing wear-out or need for adjustment
Hydraulics	
Type	Open-center hydraulic system with fixed-displacement gear pump
Pump Displacement	36.4 cc
System Relief Pressure	20 684 kPa (3,000 psi)
Maximum Flow at Unloaded High Idle	80 L/m (21 gpm)
Control	3-function direct-acting T-bar joystick with push-button angle function

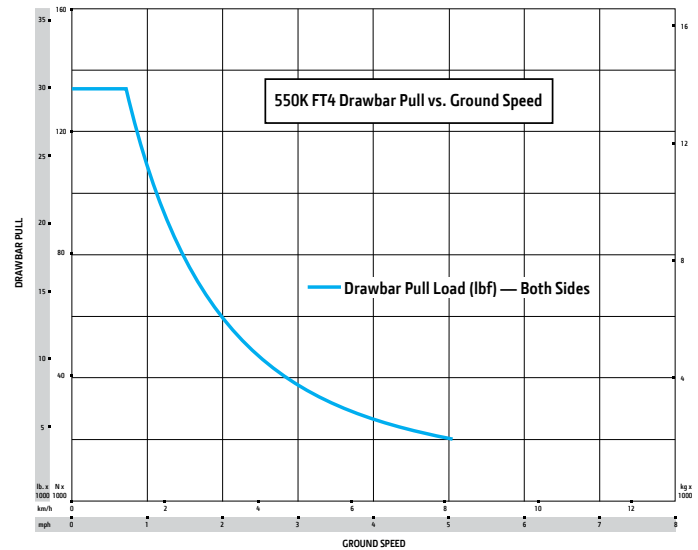



Electrical		550K XLT / 550K LGP	
Blade Type	PAT		
Voltage	24 volts		
Capacity			
Battery	950 CCA		
Reserve	190 min.		
Alternator Rating			
Cab	100 amp		
Canopy	100 amp		
Lights	Grille mounted (2), rear mounted (2), and rear reflectors (2)		
Undercarriage		550K XLT	550K LGP
Blade Type	PAT		PAT
Tracks	John Deere DuraTrax™ features large deep-heat-treated components; pins and bushings are sealed for life; rollers and idlers are permanently sealed and lubricated; full-length track-frame covers reduce material buildup and ease cleaning		
Track Gauge	1549 mm (61 in.)	1753 mm (69 in.)	
Grouser Width	457 mm (18 in.)	610 mm (24 in.)	
Chain	Sealed and lubricated		
Shoes, Each Side	42 standard / 39 Maximum Life	42 standard / 39 Maximum Life	
Track Rollers, Each Side	7	7	
Track Length on Ground	2349 mm (92 in.)	2349 mm (92 in.)	
Ground Contact Area	21 479 cm ² (3,329 sq. in.)	28 639 cm ² (4,439 sq. in.)	
Ground Pressure	39.9 kPa (5.79 psi)	31.5 kPa (4.57 psi)	
Track Pitch	160 mm (6.3 in.) standard / 171 mm (6.7 in.) Maximum Life	160 mm (6.3 in.) standard / 171 mm (6.7 in.) Maximum Life	
Operator Station		550K XLT / 550K LGP	
ROPS (ISO 3471 – 2008) and FOPS (ISO 3449 – 2005)			
Serviceability			
Refill Capacities			
Fuel Tank with Lockable Cap	234 L (61.9 gal.)		
Diesel Exhaust Fluid (DEF) Tank	11.8 L (3.1 gal.)		
Cooling System with Recovery Tank	22.6 L (6.0 gal.)		
Engine Oil with Filter	19 L (20 qt.)		
Transmission/Hydraulic Reservoir with Filter	87.8 L (23.2 gal.)		
Operating Weights		550K XLT	550K LGP
Blade Type	PAT		PAT
<i>Base Weight (with standard equipment, rollover protective structure [ROPS], full fuel tank, and 79-kg [175 lb.] operator)</i>	8908 kg (19,640 lb.)	9354 kg (20,622 lb.)	
Optional Components			
Cab with Pressurizer and Heater/Air Conditioner	306 kg (675 lb.)	306 kg (675 lb.)	
ROPS Canopy			
Heater	39 kg (85 lb.)	39 kg (85 lb.)	
Front and Door Screens	81 kg (179 lb.)	81 kg (179 lb.)	
Rear Screen	34 kg (76 lb.)	34 kg (76 lb.)	
Side Screens	43 kg (94 lb.)	43 kg (94 lb.)	
Limb Risers (ROPS canopy and cab)	104 kg (229 lb.)	104 kg (229 lb.)	
Counterweight			
Front	109 kg (240 lb.)	109 kg (240 lb.)	
Rear	150 kg (330 lb.)	150 kg (330 lb.)	
Retrieval Hitch	23 kg (50 lb.)	23 kg (50 lb.)	
Drawbar, Extended Rigid	33 kg (72 lb.)	33 kg (72 lb.)	
Winch	652 kg (1,437 lb.)	652 kg (1,437 lb.)	
Fairlead, 4 Roller	85 kg (187 lb.)	85 kg (187 lb.)	
Center Chain Guides	40 kg (88 lb.)	40 kg (88 lb.)	
Full-Length Rock Guards	128 kg (282 lb.)	128 kg (282 lb.)	
Maximum Life Undercarriage	258 kg (569 lb.)	258 kg (569 lb.)	
Track Shoes			
457 mm (18 in.)	In base	—	
610 mm (24 in.)	—	In base	

Machine Dimensions **550K XLT / 550K LGP**

A	Overall Height to Roof	2747 mm (9 ft. 0 in.)
B	Tread Depth with Single-Bar Grouser	49 mm (1.9 in.)
C	Ground Clearance in Dirt	389 mm (15.3 in.)
D	Overall Length	4128 mm (163 in.) (13 ft. 7 in.)
E	Blade Lift Height	772 mm (30.4 in.)
F	Blade Digging Depth	523 mm (20.6 in.)
G	Blade Cutting-Edge Angle, Adjustable	52 to 60 deg.

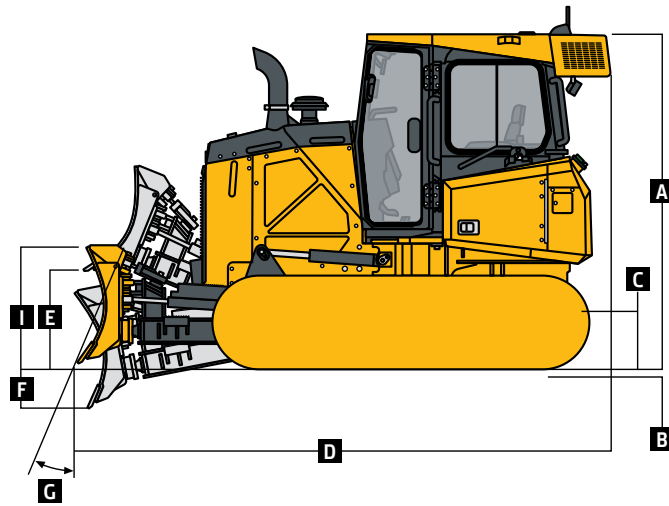

550K XLT / 550K LGP WITH POWER-ANGLE-TILT (PAT) BLADE

Machine Dimensions (continued)

	550K XLT	550K LGP	
Blade Type	PAT	PAT	
Straight			
H	Blade Width	2667 mm (105 in.) (8 ft. 9 in.)	2921 mm (115 in.) (9 ft. 7 in.)
I	Blade Height	955 mm (3 ft. 2 in.)	955 mm (3 ft. 2 in.)
	SAE Capacity	1.8 m ³ (2.4 cu. yd.)	2.0 m ³ (2.6 cu. yd.)
	Weight	603 kg (1,330 lb.)	628 kg (1,385 lb.)
	C-Frame Assembly Weight (without blade)	399 kg (879 lb.)	399 kg (879 lb.)
J	Blade Angle	22.2 deg.	22.2 deg.
K	Overall Width with Blade Angled	2469 mm (8 ft. 1 in.)	2705 mm (8 ft. 11 in.)
L	Blade Tilt (uses tilt jack)	363 mm (14.3 in.)	399 mm (15.7 in.)
M	Cut Reach	117 mm (4.6 in.)	56 mm (2.2 in.)
N	Width Over Track	2007 mm (6 ft. 7 in.)	2362 mm (7 ft. 9 in.)
O	Cast Reach	345 mm (18.3 in.)	287 mm (11 in.)
Straight (option)			
H	Blade Width	2921 mm (115 in.) (9 ft. 7 in.)	3150 mm (124 in.) (10 ft. 4 in.)
I	Blade Height	955 mm (3 ft. 2 in.)	894 mm (35 in.)
	SAE Capacity	2.0 m ³ (2.6 cu. yd.)	1.9 m ³ (2.5 cu. yd.)
	Weight	628 kg (1,385 lb.)	631 kg (1,391 lb.)
	C-Frame Assembly Weight (without blade)	399 kg (879 lb.)	399 kg (879 lb.)
J	Blade Angle	22.2 deg.	22.2 deg.
K	Overall Width with Blade Angled	2705 mm (8 ft. 11 in.)	2916 mm (9 ft. 7 in.)
L	Blade Tilt (uses tilt jack)	399 mm (15.7 in.)	429 mm (16.9 in.)
M	Cut Reach	234 mm (9.2 in.)	163 mm (6.4 in.)
N	Width Over Track	2007 mm (6 ft. 7 in.)	2464 mm (8 ft. 1 in.)
O	Cast Reach	465 mm (18.3 in.)	391 mm (15.4 in.)

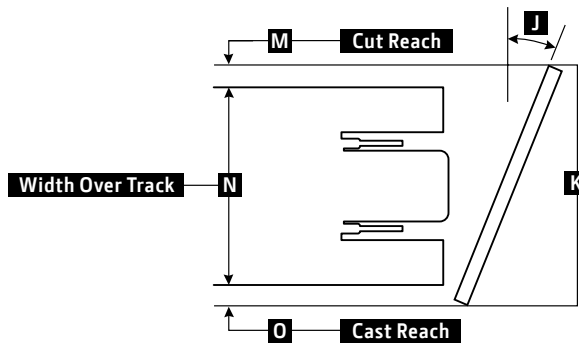
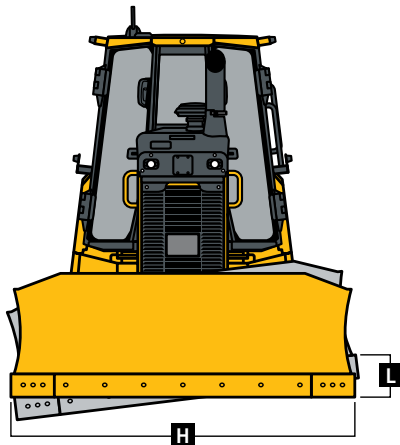

Rear Ripper **550K XLT / 550K LGP****Blade Type** PAT

Multi-shank parallelogram ripper with 5 pockets and 3 shanks

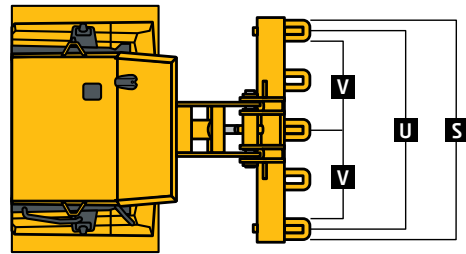
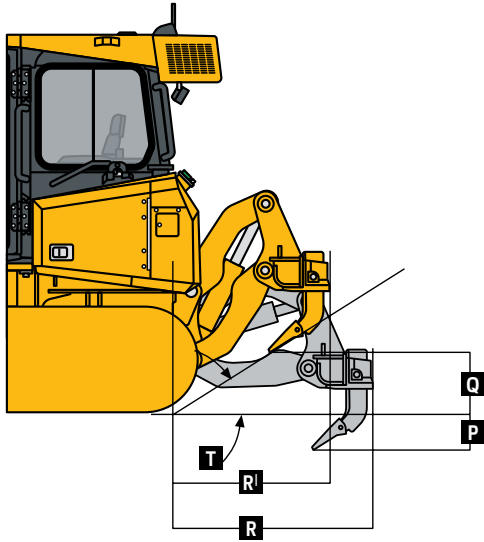
Weight 981 kg (2,163 lb.)**P** Maximum Penetration 508 mm (20 in.)**Q** Maximum Clearance Under Tip 508 mm (20 in.)**R** Overall Length, Lowered Position 1450 mm (57 in.) (4 ft. 9 in.)**R'** Overall Length, Raised Position 1015 mm (40 in.) (3 ft. 4 in.)**S** Overall Beam Width 1830 mm (6 ft. 0 in.)**T** Slope Angle (full raise) 40 deg.**U** Ripping Width 1670 mm (5 ft. 6 in.)**V** Distance Between Shanks 806 mm (32 in.)

650K



Engine	650K XLT / 650K LGP
Blade Type	<i>Power-Angle-Tilt (PAT)</i>
Manufacturer and Model	John Deere PowerTech™ PWS 4045
Non-Road Emission Standard	EPA Final Tier 4/EU Stage IV
Displacement	4.5L (276 cu. in.)
SAE Net Rated Power	78 kW (104 hp) at 2,200 rpm
Net Peak Torque	475 Nm (350 ft.-lb.) at 1,400 rpm
Aspiration	Turbocharged with charge-air cooler
Air Cleaner	Dual-stage dry tube with tangential unloader
Cooling	
Type	Variable-speed suction fan with optional reversing feature
Engine Coolant Rating	-37 deg. C. (-34 deg. F)
Engine Radiator	10 fins per in.
Powertrain	
Transmission	Automatic, dual-path, hydrostatic drive; load-sensing feature automatically adjusts speed and power to match changing load conditions; each individually controlled track is powered by a variable-displacement piston pump and motor combination; ground-speed selection buttons on single-lever steering and direction control; independently selectable reverse speed ratios of 100% , 115%, or 130% of forward ground speed; decelerator pedal controls ground speed to stop
System Relief Pressure	44 470 kPa (6,450 psi)
Travel Speeds	
Forward and Reverse	8.0 km/h (5.0 mph)
Maximum (optional)	9.7 km/h (6.0 mph)
Steering	Single-lever steering, direction control, and counter-rotation; full power turns and infinitely variable track speeds provide unlimited maneuverability and optimum control; hydrostatic steering eliminates steering clutches and brakes
Final Drives	Triple-reduction final drives mounted independently of track frames and dozer push frames for isolation from shock loads
Total Ratio	52.13 to 1
Drawbar Pull	
Maximum	148 kN (33,600 lb.)
At 1.9 km/h (1.2 mph)	106 kN (23,800 lb.)
At 3.2 km/h (2.0 mph)	68 kN (15,200 lb.)
Brakes	
Service	Hydrostatic (dynamic) braking stops the machine whenever the direction-control lever is moved to neutral or the decelerator is depressed to the detent
Parking	Exclusive spring-applied, hydraulically released park-brake feature engages wet, multiple-disc brakes automatically whenever the engine stops, the operator depresses the decelerator pedal to the brake position, the unit is in neutral for 3 seconds (with detected motion), or the park-lock lever is in the park position; machine cannot be driven with brake applied, minimizing wear-out or need for adjustment
Hydraulics	
Type	Open-center hydraulic system with fixed-displacement gear pump
Pump Displacement	36.4 cc
System Relief Pressure	20 684 kPa (3,000 psi)
Maximum Flow at Unloaded High Idle	80 L/m (21 gpm)
Control	3-function direct-acting T-bar joystick with push-button angle function

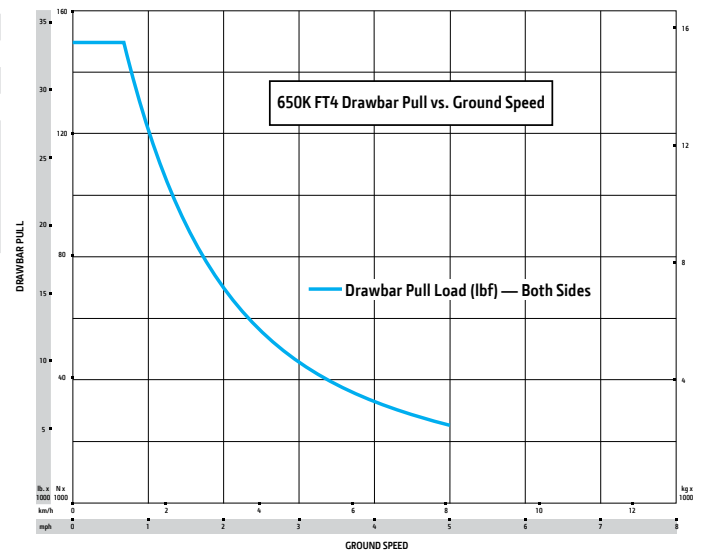



Electrical		650K XLT / 650K LGP	
Blade Type	PAT		
Voltage	24 volts		
Capacity			
Battery	950 CCA		
Reserve	190 min.		
Alternator Rating			
Cab	100 amp		
Canopy	100 amp		
Lights	Grille mounted (2), rear mounted (2), and rear reflectors (2)		
Undercarriage		650K XLT	650K LGP
Blade Type	PAT		PAT
Tracks	John Deere DuraTrax™ features large deep-heat-treated components; pins and bushings are sealed for life; rollers and idlers are permanently sealed and lubricated; full-length track-frame covers reduce material buildup and ease cleaning		
Track Gauge	1550 mm (61 in.)	1750 mm (69 in.)	
Grouser Width	457 mm (18 in.)	711 mm (28 in.)	
Chain	Sealed and lubricated	Sealed and lubricated	
Shoes, Each Side	40	40	
Track Rollers, Each Side	7	7	
Track Length on Ground	2349 mm (92 in.)	2349 mm (92 in.)	
Ground Contact Area	21 479 cm ² (3,329 sq. in.)	33 412 cm ² (5,179 sq. in.)	
Ground Pressure	40.6 kPa (5.89 psi)	27.5 kPa (3.98 psi)	
Track Pitch	171 mm (6.7 in.)	171 mm (6.7 in.)	
Operator Station		650K XLT / 650K LGP	
ROPS (ISO 3471 – 2008) and FOPS (ISO 3449 – 2005)			
Serviceability			
Refill Capacities			
Fuel Tank with Lockable Cap	234 L (61.9 gal.)		
Diesel Exhaust Fluid (DEF) Tank	11.8 L (3.1 gal.)		
Cooling System with Recovery Tank	22.6 L (6.0 gal.)		
Engine Oil with Filter	19 L (20 qt.)		
Transmission/Hydraulic Reservoir with Filter	87.8 L (23.2 gal.)		
Operating Weights		650K XLT	650K LGP
Blade Type	PAT		PAT
<i>Base Weight (with standard equipment, rollover protective structure [ROPS], full fuel tank, and 79-kg [175 lb.] operator)</i>	9049 kg (19,949 lb.)	9514 kg (20,974 lb.)	
Optional Components			
Cab with Pressurizer and Heater/Air Conditioner	306 kg (675 lb.)		306 kg (675 lb.)
ROPS Canopy			
Heater	39 kg (85 lb.)		39 kg (85 lb.)
Front and Door Screens	81 kg (179 lb.)		81 kg (179 lb.)
Rear Screen	34 kg (76 lb.)		34 kg (76 lb.)
Side Screens	43 kg (94 lb.)		43 kg (94 lb.)
Limb Risers (ROPS canopy and cab)	104 kg (229 lb.)		104 kg (229 lb.)
Counterweight			
Front	109 kg (240 lb.)		109 kg (240 lb.)
Rear	150 kg (330 lb.)		150 kg (330 lb.)
Retrieval Hitch	23 kg (50 lb.)		23 kg (50 lb.)
Drawbar, Extended Rigid	33 kg (72 lb.)		33 kg (72 lb.)
Winch	652 kg (1,437 lb.)		652 kg (1,437 lb.)
Fairlead, 4 Roller	85 kg (187 lb.)		85 kg (187 lb.)
Center Chain Guides	41 kg (90 lb.)		41 kg (90 lb.)
Full-Length Rock Guards	98 kg (216 lb.)		98 kg (216 lb.)
Maximum Life Undercarriage	182 kg (400 lb.)		182 kg (400 lb.)
Track Shoes			
457 mm (18 in.)	In base	—	
510 mm (20 in.)	83 kg (183 lb.)	– 344 kg (– 760 lb.)	
610 mm (24 in.)	—	– 172 kg (– 380 lb.)	
710 mm (28 in.)	—	In base	

Machine Dimensions	650K XLT / 650K LGP
A Overall Height to Roof	2758 mm (9 ft. 1 in.)
B Tread Depth with Single-Bar Grouser	49 mm (1.9 in.)
C Ground Clearance in Dirt	391 mm (15.4 in.)
D Overall Length	4179 mm (165 in.) (13 ft. 9 in.)
E Blade Lift Height	818 mm (32.2 in.)
F Blade Digging Depth	500 mm (19.7 in.)
G Blade Cutting-Edge Angle, Adjustable	52 to 60 deg.

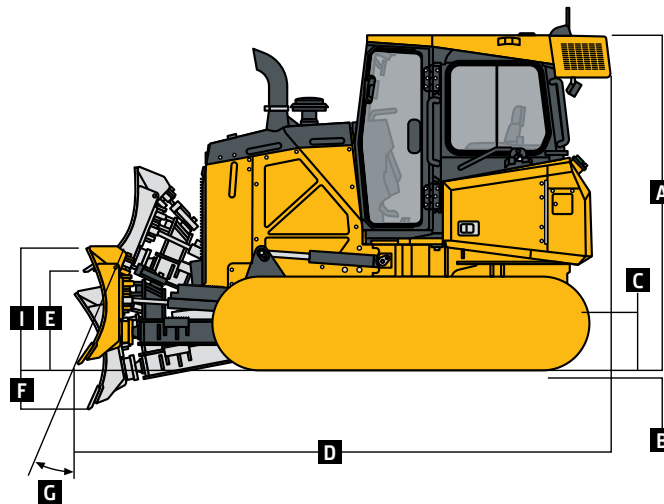

650K XLT / 650K LGP WITH POWER-ANGLE-TILT (PAT) BLADE

Machine Dimensions (continued)	650K XLT	650K LGP
Blade Type	PAT	PAT
Straight		
H Blade Width	2667 mm (105 in.) (8 ft. 9 in.)	2921 mm (115 in.) (9 ft. 7 in.)
I Blade Height	1067 mm (3 ft. 6 in.)	955 mm (3 ft. 2 in.)
SAE Capacity	2.2 m ³ (2.9 cu. yd.)	2.0 m ³ (2.6 cu. yd.)
Weight	603 kg (1,330 lb.)	628 kg (1,385 lb.)
C-Frame Assembly Weight (without blade)	399 kg (879 lb.)	399 kg (879 lb.)
J Blade Angle	22.2 deg.	22.2 deg.
K Overall Width with Blade Angled	2469 mm (8 ft. 1 in.)	2705 mm (8 ft. 11 in.)
L Blade Tilt (uses tilt jack)	363 mm (14.3 in.)	399 mm (15.7 in.)
M Cut Reach	117 mm (4.6 in.)	5 mm (0.2 in.)
N Width Over Track	2007 mm (6 ft. 7 in.)	2464 mm (8 ft. 1 in.)
O Cast Reach	345 mm (13.6 in.)	236 mm (9.3 in.)
Straight (option)		
H Blade Width	2921 mm (115 in.) (9 ft. 7 in.)	3150 mm (124 in.) (10 ft. 4 in.)
I Blade Height	955 mm (3 ft. 2 in.)	894 mm (35 in.)
SAE Capacity	2.0 m ³ (2.6 cu. yd.)	1.9 m ³ (2.5 cu. yd.)
Weight	628 kg (1,385 lb.)	631 kg (1,391 lb.)
C-Frame Assembly Weight (without blade)	399 kg (879 lb.)	399 kg (879 lb.)
J Blade Angle	22.2 deg.	22.2 deg.
K Overall Width with Blade Angled	2705 mm (8 ft. 11 in.)	2916 mm (9 ft. 7 in.)
L Blade Tilt (uses tilt jack)	399 mm (15.7 in.)	429 mm (16.9 in.)
M Cut Reach	234 mm (9.2 in.)	112 mm (4.4 in.)
N Width Over Track	2007 mm (6 ft. 7 in.)	2464 mm (8 ft. 1 in.)
O Cast Reach	465 mm (18.3 in.)	340 mm (13.4 in.)

Machine Dimensions (continued)		650K XLT	650K LGP
Blade Type		PAT	PAT
Straight (option)			
H	Blade Width	3150 mm (124 in.) (10 ft. 4 in.)	3251 mm (128 in.) (10 ft. 8 in.)
I	Blade Height	894 mm (35 in.)	955 mm (3 ft. 2 in.)
	SAE Capacity	1.9 m ³ (2.5 cu. yd.)	2.2 m ³ (2.9 cu. yd.)
	Weight	631 kg (1,391 lb.)	694 kg (1,530 lb.)
	C-Frame Assembly Weight (without blade)	399 kg (879 lb.)	399 kg (879 lb.)
J	Blade Angle	22.2 deg.	22.2 deg.
K	Overall Width with Blade Angled	2916 mm (9 ft. 7 in.)	3010 mm (9 ft. 11 in.)
L	Blade Tilt (uses tilt jack)	429 mm (16.9 in.)	445 mm (17.5 in.)
M	Cut Reach	340 mm (13.4 in.)	157 mm (6.2 in.)
N	Width Over Track	2007 mm (6 ft. 7 in.)	2464 mm (8 ft. 1 in.)
O	Cast Reach	569 mm (22.4 in.)	569 mm (22.4 in.)

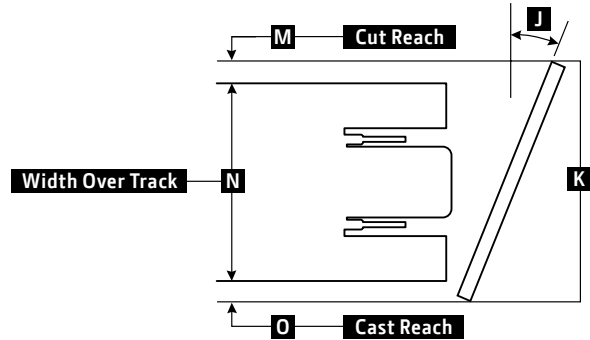
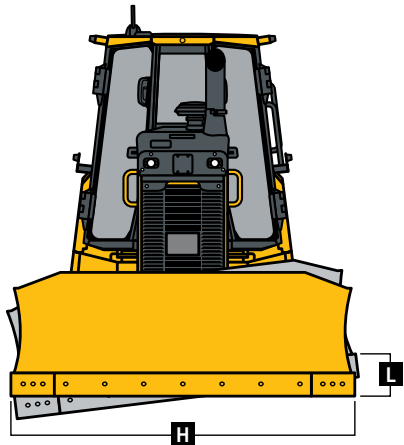

Rear Ripper		650K XLT / 650K LGP
Blade Type		PAT
Multi-shank parallelogram ripper with 5 pockets and 3 shanks		
	Weight	981 kg (2,163 lb.)
P	Maximum Penetration	508 mm (20 in.)
Q	Maximum Clearance Under Tip	508 mm (20 in.)
R	Overall Length, Lowered Position	1450 mm (57 in.) (4 ft. 9 in.)
R'	Overall Length, Raised Position	1015 mm (40 in.) (3 ft. 4 in.)
S	Overall Beam Width	1830 mm (6 ft. 0 in.)
T	Slope Angle (full raise)	40 deg.
U	Ripping Width	1670 mm (5 ft. 6 in.)
V	Distance Between Shanks	806 mm (32 in.)

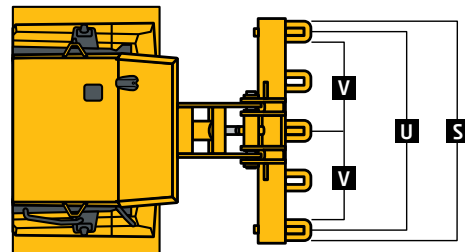
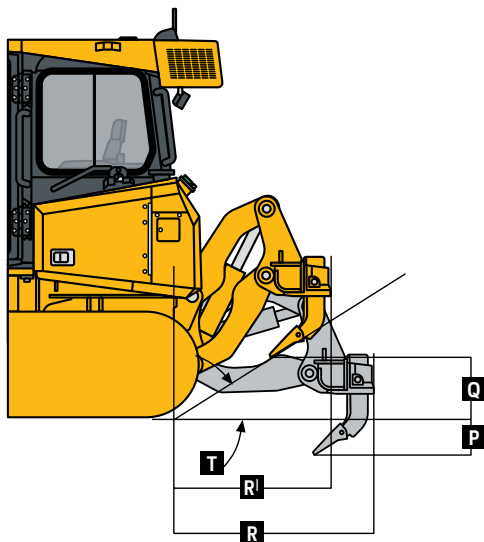

700K

Engine	700K XLT / 700K LGP
Blade Type	<i>Power-Angle-Tilt (PAT)</i>
Manufacturer and Model	John Deere PowerTech™ PVS 6068
Non-Road Emission Standard	EPA Final Tier 4/EU Stage IV
Displacement	6.8L (414 cu. in.)
SAE Net Rated Power	97 kW (130 hp) at 1,800 rpm
Net Peak Torque	559 Nm (412 ft.-lb.) at 1,500 rpm
Aspiration	Turbocharged with charge-air cooler
Air Cleaner	Dual-stage dry tube with tangential unloader
Cooling	
Type	Variable-speed suction fan with optional reversing feature
Engine Coolant Rating	-37 deg. C. (-34 deg. F)
Engine Radiator	10 fins per in.
Powertrain	
Transmission	Automatic, dual-path, hydrostatic drive; load-sensing feature automatically adjusts speed and power to match changing load conditions; each individually controlled track is powered by a variable-displacement piston pump and motor combination; ground-speed selection buttons on single-lever steering and direction control; independently selectable reverse speed ratios of 100% , 115% , or 130% of forward ground speed; decelerator pedal controls ground speed to stop
System Relief Pressure	47 573 kPa (6,900 psi)
Travel Speeds	
Forward and Reverse	8.9 km/h (5.5 mph)
Maximum (optional)	9.7 km/h (6.0 mph)
Steering	Single-lever steering, direction control, and counter-rotation; full power turns and infinitely variable track speeds provide unlimited maneuverability and optimum control; hydrostatic steering eliminates steering clutches and brakes
Final Drives	Triple-reduction final drives mounted independently of track frames and dozer push frames for isolation from shock loads
Total Ratio	33.59 to 1
Drawbar Pull	
Maximum	200 kN (45,000 lb.)
At 1.9 km/h (1.2 mph)	119 kN (26,800 lb.)
At 3.2 km/h (2.0 mph)	77 kN (17,200 lb.)
Brakes	
Service	Hydrostatic (dynamic) braking stops the machine whenever the direction-control lever is moved to neutral or the decelerator is depressed to the detent
Parking	Exclusive spring-applied, hydraulically released park-brake feature engages wet, multiple-disc brakes automatically whenever the engine stops, the operator depresses the decelerator pedal to the brake position, the unit is in neutral for 3 seconds (with detected motion), or the park-lock lever is in the park position; machine cannot be driven with brake applied, minimizing wear-out or need for adjustment
Hydraulics	
Type	Open-center hydraulic system with fixed-displacement gear pump
Pump Displacement	44 cc
System Relief Pressure	22 063 kPa (3,200 psi)
Maximum Flow at Unloaded High Idle	95 L/m (25 gpm)
Control	3-function direct-acting T-bar joystick with push-button angle function

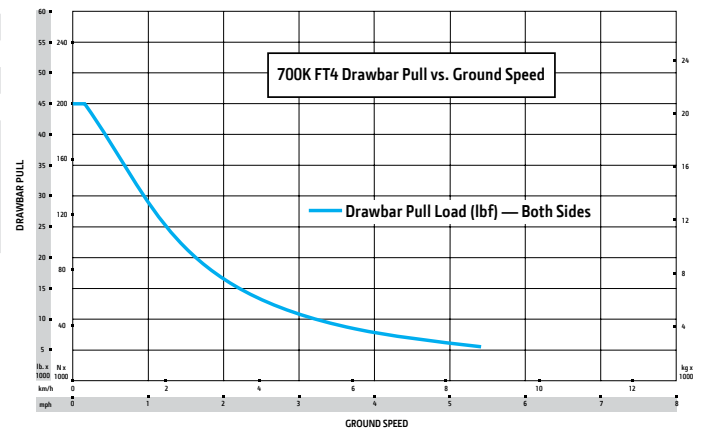



Electrical	700K XLT / 700K LGP	
Blade Type	PAT	
Voltage	24 volts	
Capacity		
Battery	950 CCA	
Reserve	190 min.	
Alternator Rating		
Cab	130 amp	
Canopy	100 amp	
Lights	Grille mounted (2), rear mounted (2), and rear reflectors (2)	
Undercarriage	700K XLT	700K LGP
Blade Type	PAT	PAT
Tracks	John Deere DuraTrax™ features large deep-heat-treated components; pins and bushings are sealed for life; rollers and idlers are permanently sealed and lubricated; sprockets are segmented; full-length track-frame covers reduce material buildup and ease cleaning	
Track Gauge	1778 mm (70 in.)	1981 mm (78 in.)
Grouser Width	560 mm (22 in.)	760 mm (30 in.)
Chain	Sealed and lubricated	Sealed and lubricated
Shoes, Each Side	39	39
Track Rollers, Each Side	7	7
Track Length on Ground	2590 mm (102 in.)	2590 mm (102 in.)
Ground Contact Area	29 946 cm ² (4,487 sq. in.)	39 472 cm ² (6,118 sq. in.)
Ground Pressure	46.4 kPa (6.74 psi)	35.2 kPa (5.11 psi)
Track Pitch	191 mm (7.5 in.)	191 mm (7.5 in.)
Oscillation at Front Roller	± 94 mm (± 3.7 in.)	± 94 mm (± 3.7 in.)
Operator Station	700K XLT / 700K LGP	
ROPS (ISO 3471 – 2008) and FOPS (ISO 3449 – 2005)		
Serviceability		
Refill Capacities		
Fuel Tank with Lockable Cap	301 L (79.5 gal.)	
Diesel Exhaust Fluid (DEF) Tank	11.8 L (3.1 gal.)	
Cooling System with Recovery Tank	35.06 L (9.3 gal.)	
Engine Oil with Filter	24.6 L (6.5 gal.)	
Reservoir with Filter		
Transmission	68.9 L (18.2 gal.)	
Hydraulic	53.8 L (14.2 gal.)	
Operating Weights	700K XLT	700K LGP
Blade Type	PAT	PAT
<i>Base Weight (with standard equipment, rollover protective structure [ROPS], full fuel tank, and 79-kg [175 lb.] operator)</i>	13 733 kg (30,275 lb.)	14 193 kg (31,290 lb.)
Optional Components		
Cab with Pressurizer and Heater/Air Conditioner	288 kg (635 lb.)	288 kg (635 lb.)
ROPS Canopy		
Heater	39 kg (85 lb.)	39 kg (85 lb.)
Front and Door Screens	54 kg (120 lb.)	54 kg (120 lb.)
Rear Screen	20 kg (45 lb.)	20 kg (45 lb.)
Side Screens	54 kg (120 lb.)	54 kg (120 lb.)
Cab with Air Conditioner		
Front and Door Screens	68 kg (151 lb.)	68 kg (151 lb.)
Rear Screen	41 kg (91 lb.)	41 kg (91 lb.)
Side Screens	68 kg (151 lb.)	68 kg (151 lb.)
Limb Risers (ROPS canopy and cab)	155 kg (341 lb.)	155 kg (341 lb.)
Front Counterweight	172 kg (380 lb.)	172 kg (380 lb.)
Retrieval Hitch	31 kg (68 lb.)	31 kg (68 lb.)
Drawbar, Extended Rigid	88 kg (195 lb.)	88 kg (195 lb.)
Winch	652 kg (1,437 lb.)	652 kg (1,437 lb.)
Fairlead, 4 Roller	85 kg (187 lb.)	85 kg (187 lb.)
Full-Length Rock Guards	130 kg (287 lb.)	130 kg (287 lb.)
Maximum Life Undercarriage	373 kg (822 lb.)	373 kg (822 lb.)

Operating Weights (continued)	700K XLT	700K LGP
Blade Type	PAT	PAT
Optional Components (continued)		
Track Shoes		
560 mm (22 in.)	In base	- 493 kg (- 1,086 lb.)
610 mm (24 in.)	—	- 371 kg (- 818 lb.)
760 mm (30 in.)	—	In base
Swamp Shoes, 760 mm (30 in.)	—	- 14 kg (- 31 lb.)
Machine Dimensions		
700K XLT / 700K LGP		
A Overall Height to Roof	2936 mm (9 ft. 8 in.)	
B Tread Depth with Single-Bar Grouser	56 mm (2.2 in.)	
C Ground Clearance in Dirt	393 mm (15.5 in.)	
D Overall Length	4815 mm (189 in.) (15 ft. 9 in.)	
Overall Length with Extended Drawbar	5033 mm (198 in.) (16 ft. 6 in.)	
Overall Length with Winch and Fairlead Rollers	5395 mm (212 in.) (17 ft. 8 in.)	
E Blade Lift Height	991 mm (3 ft. 3 in.)	
F Blade Digging Depth	533 mm (21 in.)	
G Blade Cutting-Edge Angle, Adjustable	52 to 60 deg.	

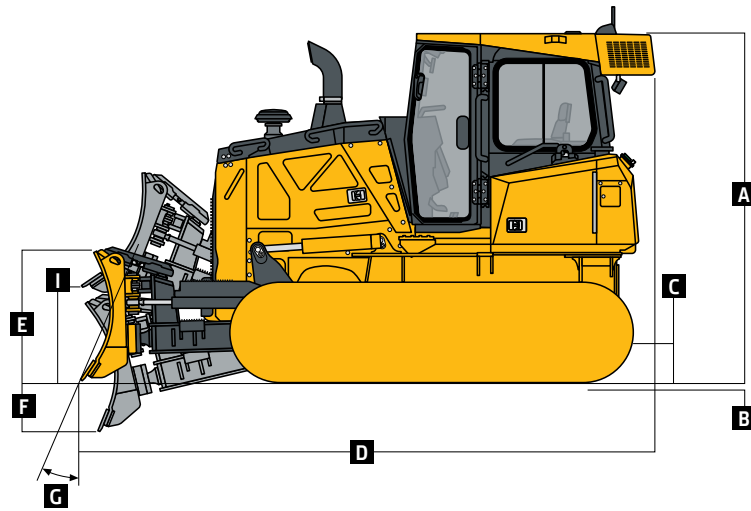

700K XLT / 700K LGP WITH POWER-ANGLE-TILT (PAT) BLADE

Machine Dimensions (continued)	700K XLT	700K LGP
Blade Type	PAT	PAT
Straight		
H Blade Width	3200 mm (126 in.) (10 ft. 6 in.)	3658 mm (144 in.) (12 ft. 0 in.)
I Blade Height	991 mm (39 in.) (3 ft. 3 in.)	991 mm (39 in.) (3 ft. 3 in.)
SAE Capacity	2.7 m ³ (3.6 cu. yd.)	3.2 m ³ (4.1 cu. yd.)
Weight	804 kg (1,771 lb.)	901 kg (1,986 lb.)
C-Frame Assembly Weight (without blade)	663 kg (1,461 lb.)	663 kg (1,461 lb.)
J Blade Angle	25 deg.	25 deg.
K Overall Width with Blade Angled	2907 mm (114.5 in.) (9 ft. 6.5 in.)	3324 mm (130.9 in.) (10 ft. 10.9 in.)
L Blade Tilt (uses tilt jack)	445 mm (17.5 in.)	482 mm (19 in.)
M Cut Reach	94 mm (3.7 in.)	113 mm (4.5 in.)
N Width Over Track	2337 mm (92 in.) (7 ft. 8 in.)	2743 mm (108 in.) (9 ft. 0 in.)
O Cast Reach	450 mm (17.7 in.)	468 mm (18.4 in.)

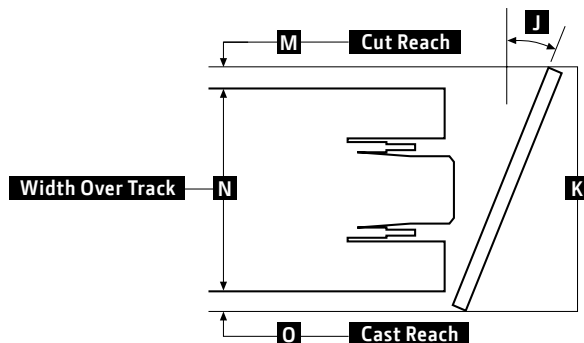
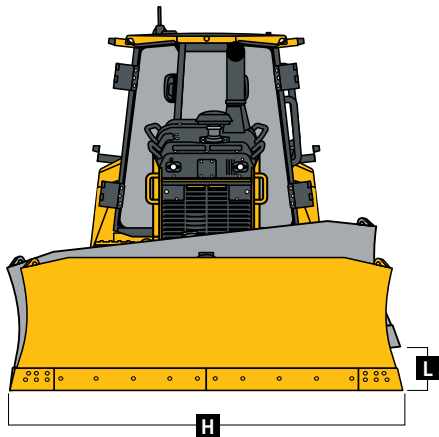

Rear Ripper **700K XLT / 700K LGP****Blade Type** PAT

Multi-shank parallelogram ripper with 5 pockets and 3 shanks

Weight	1444 kg (3,183 lb.)
P Maximum Penetration	563 mm (22 in.)
Q Maximum Clearance Under Tip	584 mm (23 in.)
R Overall Length, Lowered Position	1494 mm (59 in.) (4 ft. 11 in.)
R' Overall Length, Raised Position	1210 mm (48 in.) (4 ft. 0 in.)
S Overall Beam Width	1930 mm (6 ft. 4 in.)
T Slope Angle (full raise)	26 deg.
U Ripping Width	1673 mm (5 ft. 6 in.)
V Distance Between Shanks	806 mm (32 in.)

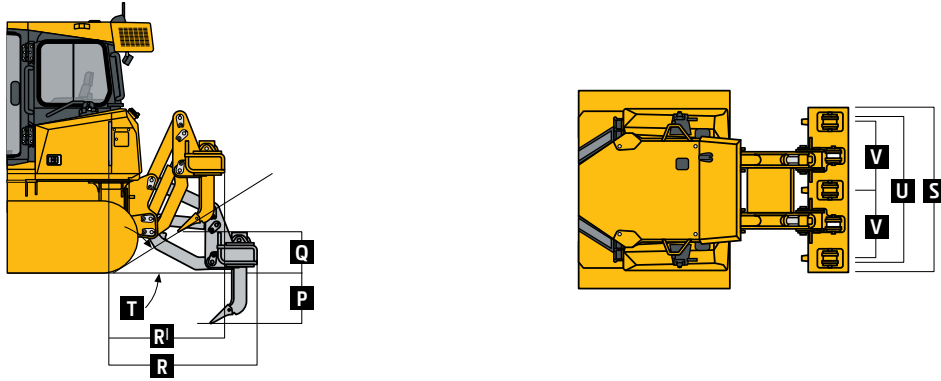
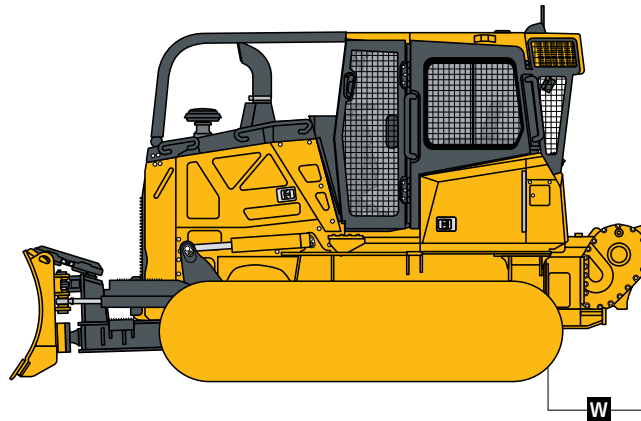
**4000S Winch** **700K XLT / 700K LGP****Blade Type** PAT**W** Winch Length 798 mm (31 in.)

Additional equipment

Key: ● Standard ▲ Optional or special

*See your John Deere dealer for further information.

550K	650K	700K	Engine
●	●	●	Meets EPA Final Tier 4/EU Stage IV emissions
●	●	●	Electronic control with automatic engine protection
●	●		Dual safety element dry-type air cleaner, evacuator valve
		●	Dual-element dry-tube air cleaner with tangential unloader valve
●	●	●	Exhaust filter, under hood, with vertical stack
●	●	●	Engine glow-plug starting system
●	●	●	Programmable auto engine shutdown
●	●	●	Automatic turbo cool-down timer
●	●	●	Environmental service drains
●	●	●	Wet-sleeve cylinder liners
●	●	●	Remote-mounted fuel filters with automatic electronic priming
▲	▲		Engine coolant heater, 110 volts
		▲	Engine block heater, 110 volts
▲	▲	▲	Engine coolant heater, fuel fired
▲	▲	▲	Chrome exhaust
		▲	Rotary ejector engine air pre-cleaner
▲	▲	▲	Fluid-sample valves
▲	▲		Quick-service ports
▲	▲	▲	Severe-duty 400-mL (13.5 oz.) fuel filter and water separator with heating element
Cooling			
●	●	●	Tilt-out cooling fan, hydraulically driven, variable-speed suction type
▲	▲	▲	Automatic, programmable reversing-fan-drive fan
		●	Engine coolant radiator (10 fins per in.)
		●	Hydrostatic cooler (oil/air – 10.2 fins per in.)
		●	Hydraulic cooler (oil/air – 10.2 fins per in.)
●	●	●	Enclosed safety fan guard (conforms to SAE J1308 and ISO3457)
▲	▲	▲	Perforated engine side shields
●	●	●	Heavy-duty tilt-out bar-type grille
		●	2-side access to all coolers
		●	Cooling package isolated from engine compartment
●	●	●	Heavy-duty, trash-resistant radiator and high-ambient cooling package
▲	▲	▲	Extreme-duty tilt-out grille
Powertrain			
●	●	●	Remote diagnostic test ports
●	●	●	Automatic cold-weather transmission warmup system
●	●	●	Automatic transmission derating for exceeded system temperatures
●	●	●	Environmental service drains
●	●	●	Sealed dedicated transmission reservoir and filtration system separate from hydraulic system
●	●	●	2,000-hour vertical spin-on transmission filter

550K	650K	700K	Hydraulic System
●	●		3-function hydraulics
		●	Hydraulic cooler
●	●	●	2,000-hour vertical spin-on hydraulic filter
▲	▲	▲	4-function hydraulics with rear plumbing
▲	▲	▲	Drive-through hydraulic pump for use with winch
▲	▲	▲	Grade-control-ready hydraulics (EH)
▲	▲	▲	Topcon integrated grade control
Mainframe, Access Panels			
●	●	●	Front tow loop
●	●		Reinforced engine and mid-frame bottom guards
●	●		Integral transmission guard
		●	Integral bottom protection
		●	Hinged bottom access covers (bolt-on)
●	●		Vandal protection: Engine access door / Side tank access doors / Fuel tank / Instrument panel / Transmission reservoir / Hydraulic reservoir
Attachments			
▲	▲		Counterweight, front, 109 kg (240 lb.)
		▲	Counterweight, front, 172 kg (380 lb.)
▲	▲		Counterweight, rear, 150 kg (330 lb.)
▲	▲	▲	Retrieval hitch with pin
▲	▲	▲	Extended rigid drawbar with pin for pull-type implements
▲	▲	▲	Drawbar, extended for winch (with or without fairlead)
▲	▲	▲	Ripper, parallelogram with 5 shank pockets and 3 teeth
▲	▲	▲	Winch, John Deere 4000S, power in/free spool out OR power out
▲	▲	▲	4-roller fairlead for winch
▲	▲	▲	Root-rake blade attachment
▲	▲		Rear-mounted toolbox
		▲	Operator-protection package
		▲	Forestry-protection package
▲	▲	▲	Trimble-ready interface package
▲	▲	▲	Topcon-ready interface package
▲	▲	▲	Leica-ready interface package
Undercarriage			
●	●	●	Full-length, smooth-surface track frame covers
		●	Segmented sprockets
●	●	●	Double-flange rollers
●	●	●	Maximum Life Undercarriage System
		●	Oscillating undercarriage
▲	▲	▲	Heavy-duty sealed and lubricated undercarriage
▲	▲	▲	Full-length rock guards
XLT LGP 550K Shoes			
●	▲		457-mm (18 in.) moderate service
		●	610-mm (24 in.) moderate service

XLT	LGP	650K Shoes
●	▲	457-mm (18 in.) moderate service
▲	▲	510-mm (20 in.) moderate service with clipped corners
	▲	610-mm (24 in.) moderate service
	●	710-mm (28 in.) moderate service with clipped corners
XLT LGP 700K Shoes		
●	▲	560-mm (22 in.) moderate service
	▲	610-mm (24 in.) moderate service
	●	760-mm (30 in.) moderate service
Canopy Cab Operator's Station / Electrical		
●	●	Retractable seat belts, 76 mm (3 in.) (conform to SAE J386)
●	●	Convex interior rearview mirror, 102-mm (4 in.) tall, 203-mm (8 in.) wide (conforms to SAE J985)
●	●	Power port, 12 volts, 10 amps
●	●	Lockable dash-mounted storage compartment
●	●	Cup holders (2)
●	●	Air conditioner, 24,000 Btu
●	●	Tinted glass
●	●	Dome light
●	●	Heater (roof mount)
●	●	Wipers (intermittent plus 2 speeds) and washers – front window, left and right doors
	▲	Rear wiper and washer
●		Air-ride vinyl seat
	●	Air-ride fabric seat
	▲	Deluxe heated and leather-bolstered air-ride seat
▲	●	Under-seat heater
	●	AM/FM, weather-band radio, clock, and MP3 player front plug-in
	●	Radio-area storage slot with power port
●	●*	Sealed alternator, 100 amps
	●	Sealed alternator, 130 amps†
●	●	Lockable master electrical disconnect switch
●	●	Multi-function/multi-language LCD monitor: Analog display (fuel level, coolant temperature, and engine oil pressure) / Digital display (engine rpm, charge pressure, hours, DPF soot level, and transmission direction/speed range)
●	●	Built-in diagnostics: Diagnostic-code details / Sensor values / Calibrations / Individual circuit tester
●	●	Keyless start with multiple security modes
●	●	Battery, dual, 24 volts*
●	●	Lights, grille mounted (2), rear mounted (2)
▲	▲	Work lights, roof mounted (2)
▲	▲	Engine compartment light
▲	▲	External-mounted rear-attachment mirror†
▲	▲	Quick-service ports†
●	●	JDLink™ Ultimate wireless communication system (available in specific countries; see your dealer for details)

*550K and 650K only.

†700K only.



Net engine power is with standard equipment including air cleaner, exhaust system, alternator, and cooling fan at test conditions specified per ISO9249. Specifications and design subject to change without notice. Wherever applicable, specifications are in accordance with SAE standards. Except where otherwise noted, these specifications are based on units with standard equipment, rollover protective structures (ROPS), full fuel tanks, and 79-kg (175 lb.) operators.

JohnDeere.com