

TRACKED FELLER BUNCHERS/HARVESTERS

803M/MH / 853M/MH / 859M/MH



JOHN DEERE



PROVEN
PERFORMANCE

OUTRUN EXPECTATIONS.





KEEP BACK 300FT/90M

RM1823c

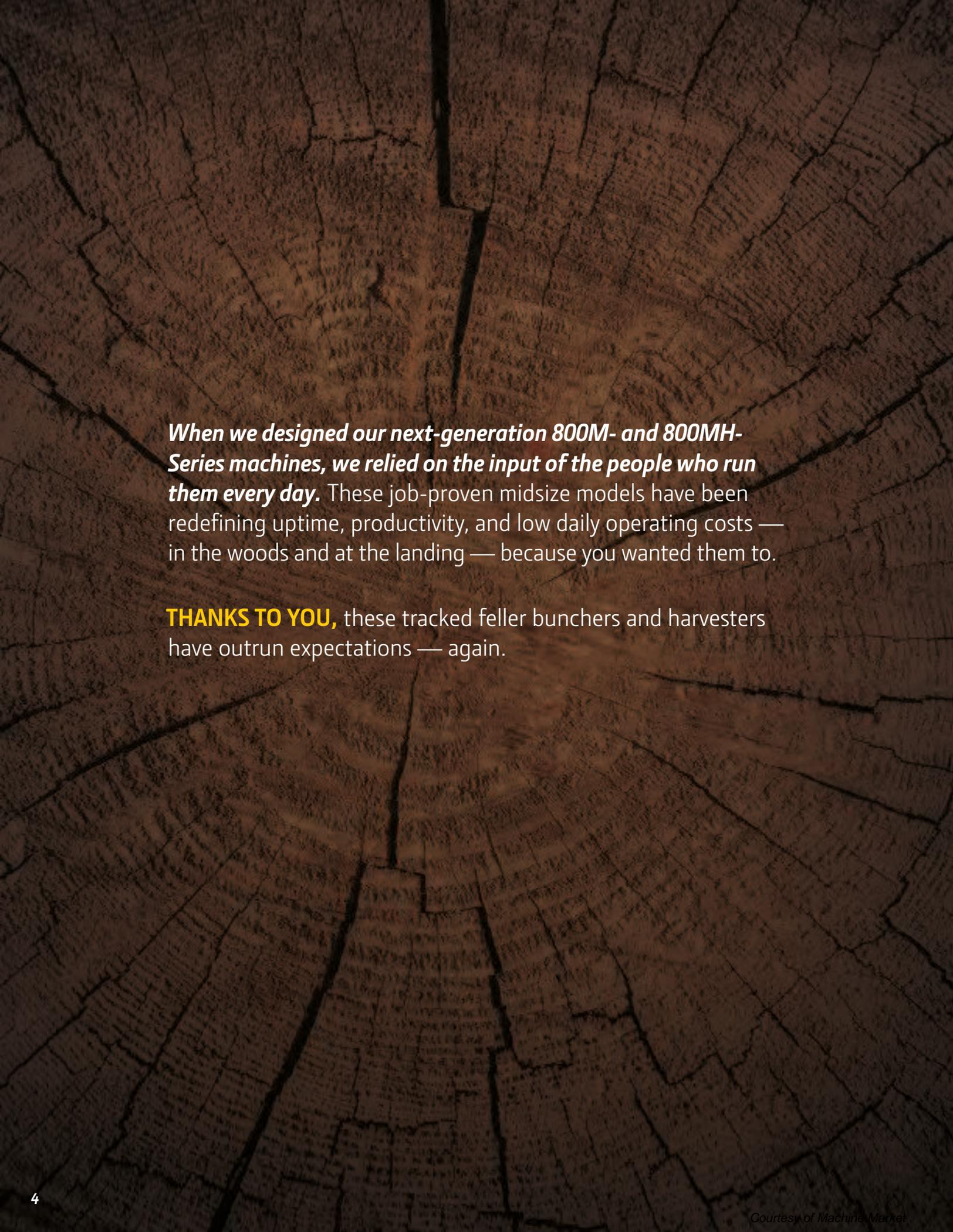

When we designed our next-generation 800M- and 800MH-Series machines, we relied on the input of the people who run them every day. These job-proven midsize models have been redefining uptime, productivity, and low daily operating costs — in the woods and at the landing — because you wanted them to.

THANKS TO YOU, these tracked feller bunchers and harvesters have outrun expectations — again.

YOU ASKED FOR IT

Built for the way you work.

Ongoing input from Customer Advocate Groups (CAGs) helps make 800M- and 800MH-Series machines even more rugged and reliable.

Engine power

Powerful engine output adapts to the application, for reliable multifunction performance.

Closed-loop hydrostatic drive

Boost multifunctioning even more, particularly on slopes and in rough terrain. Adjust priority between track drive and other hydraulic functions to match site conditions and operator style or preference.

Surefooted stability

Long, wide undercarriage provides solid balance to maximize stability, no matter the terrain.

High-torque swing option

If you're working in really big timber or on hills, high-torque swing — standard on harvester models, optional on feller bunchers — provides increased power, for more productivity.

Ample tractive effort

Strong tractive effort generously increases capability for negotiating difficult or steep terrain, deep snow, and swamps.

Smart debris management

Designed to keep your workspace free and clear, the productivity-boosting debris-management system is integrated into the hood and left-side guarding to keep materials and debris from entering the cooling package. External screening, sealed cooler compartment, and standard reversing fan further protect vital components.

Multiple boom-set/ felling-head combinations

A variety of boom sets and felling heads can be combined to optimize productivity across a wide range of conditions.



MAXIMIZE PRODUCTIVITY

Rapid Cycle System.

Faster, low-effort joystick control of all boom functions helps operators of 800M- and 800MH-Series machines be more productive. New Rapid Cycle System (RCS) combines automated felling-head arm cycling with simple boom control — dramatically reducing operator fatigue while increasing efficiency and productivity.

Adaptable to preferences and environments

RCS can be tailored to individual skill levels and specific harvesting conditions, from large single-tree harvesting to high-speed, multi-stem cutting.

Operator-specific settings

Multiple RCS settings can be saved according to individual operator preferences. Novices may prefer a slower, more methodical pace, while highly skilled pros may want faster response.

Selectable operation

Press a single button to engage RCS mode. Conditions don't suit the fast, parallel motion of the boom? Turn RCS off with another touch of a button.



SAVE TIME



COVER MORE AREA

ALL IN ONE

MULTIPLE
OPERATOR SETTINGS

ONE-BUTTON
ACTIVATION



KEEP BACK 360° T190M

FT4 IN THE FOREST

Tiers without fears.

You asked for the latest technology to meet FT4/ Stage IV emission regulations, and we listened and delivered. In fact, we're always focused on implementing the right engine solutions at the right time — without compromise of power, reliability, or ease of operation.

Fluid-efficient FT4 engines

Our FT4/Stage IV PowerTech™ PSS diesels meet emission regulations without sacrificing power or torque. Built on our EPA Interim Tier 4 (IT4)/EU Stage IIIB solution, this simple technology delivers a winning combination of performance, fluid efficiency, and reliability.

Minimal impact on operation

Under normal operating conditions, the engine's natural heat breaks down trapped particulate matter and cleans the exhaust filter without impacting machine operation. Ash-service intervals for the diesel particulate filter (DPF) are condition based, meaning machine alerts will notify the operator before service is required. Typically, ash service is not necessary until the first engine overhaul depending on machine application, regular maintenance practices, and type of lubricating oil.

Low total fluid consumption

John Deere FT4 engines maintain peak engine performance while minimizing total fluid consumption — diesel fuel plus diesel exhaust fluid (DEF). This exceptionally conservative DEF-use rate is four to six times lower than that of some other FT4 systems.

Up to **6X LOWER**

**DEF-CONSUMPTION RATE
THAN SOME FT4 SYSTEMS**

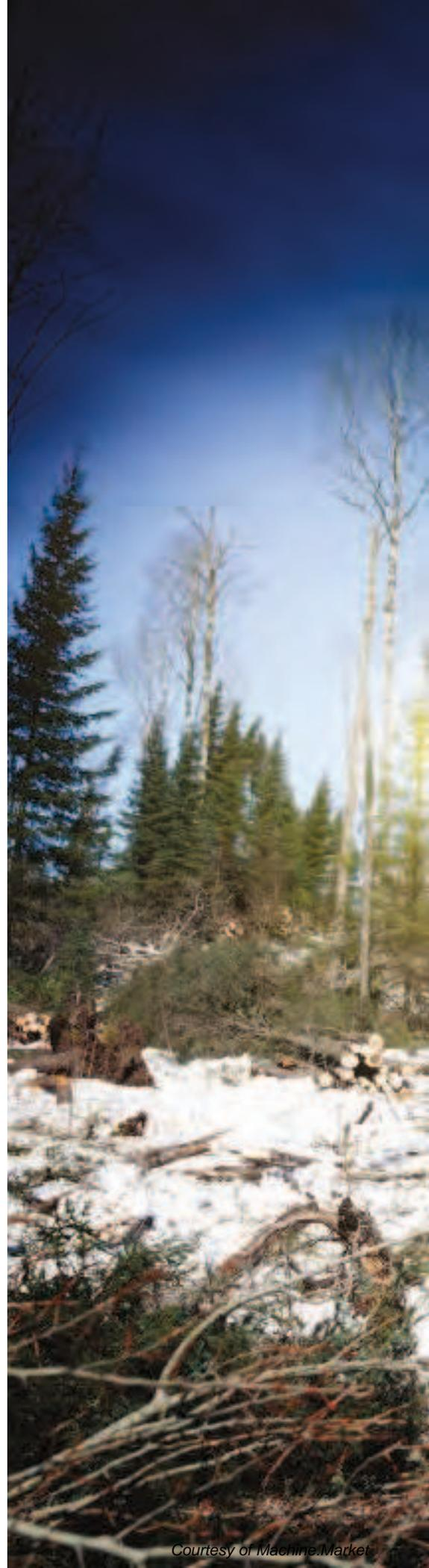



FT4

EPA FINAL TIER 4 (FT4)/EU STAGE IV
POWERTECH DIESEL ENGINES



10X LONGER-
LASTING

MARINE-GRADE CONTROL CENTER

OPERATE IN COMFORT

Room with a view.

Spacious operator station was designed by loggers for loggers. It's roomier and more comfortable, with ergonomically designed controls. And the view has to be seen to be believed, with significantly more window area, for improved visibility.



Low-effort control

Fully adjustable armrests, including mounted keypads, provide fingertip control of all machine functions. Fully adjustable air-cushioned seat provides outstanding daylong comfort in the climate-controlled cab.

Sealed-switch module

Sealed touchpad keeps out dust, moisture, and debris, minimizing wear. Proven marine-grade control center eliminates rocker switches, numerous wires, and unsealed connections, and lasts up to 10 times longer than standard dash switches.

Expansive visibility

Floor-to-ceiling front window significantly expands the view of the cutting area and the work at hand.

EXPECT MORE

And then some.

In the woods, uptime is the name of the game. That's why we went to our toughest customers, loggers just like you, to continually reinvent the rugged 800M and 800MH-Series Tracked Feller Bunchers and Tracked Harvesters.

Robust booms

Field-proven boom design is transplanted from our larger 900M- and 900MH-Series models. All booms are strong and robust, with thick plates and large pins and bushings, to extend wear life.

Stable and able

Reliable stability and solid engine horsepower help make quick work of the woods in all conditions.

Larger fuel tanks

Fuel-tank capacity has been increased by over 50 percent (to 230 versus 154 gal. on comparably sized machines) to extend intervals between fill-ups, allowing you to run up to 24 hours without refueling.

Optional toolbox

Optional undercarriage-mounted toolbox provides convenient storage for tools, additional saw bars, and other spare parts, minimizing trips back to the service truck.

Through-nose harvester-head plumbing

Through-nose plumbing option routes hoses up and out of harm's way to extend hose wear life, increasing uptime and reducing operating costs.



WARNING



**230-GAL.
FUEL TANK**
RUNS UP TO 24 HOURS W/O REFILL

KEEP BACK 300FT/100M

Waratah



**JOHN DEERE ULTIMATE UPTIME/
JOHN DEERE FORESTSIGHT™/TIMBERNAVI™**

Save time and money.

As a logger, one of your most valuable commodities is uptime. You need fast, accurate diagnosis of machine issues, rapid service response, and tracking of equipment and operators to maximize efficiency and productivity. We have John Deere forestry solutions to help you do that, and more.



Keep downtime down with

JOHN DEERE ULTIMATE UPTIME

In addition to the base John Deere ForestSight features, our dealers work with you to build an uptime package that meets your specific needs, including customized maintenance and repair agreements, onsite parts availability, extended warranties, fluid sampling, response-time guarantees, and more.

Get valuable insight with

JOHN DEERE FORESTSIGHT

Alerts can be sent to your computer or mobile device — or your dealer, if you choose — to inform you of immediate machine issues. If downtime does occur, exclusive remote diagnostics and programming enable your Deere dealer to minimize the time and cost associated with sending a technician to the logging site for an initial diagnostic visit. You can also receive reminders of periodic scheduled maintenance on your computer or mobile device, or from your dealer.

More visibility, more profitability

TimberNavi is a proven jobsite-mapping solution designed for full-tree logging operations. It gives you in-machine visibility of current position, harvesting area, points of interest, and more. Alarm functionality gives operators increased awareness of cut-block boundaries and hazards, and a 10-in. high-resolution display makes the entire jobsite visible at a glance. By delivering accurate location information in real time, TimberNavi enables operators to navigate confidently and efficiently through the jobsite.

Simplified serviceability

Easy access to service components helps confirm daily checks and preventative maintenance get done on schedule, minimizing costly repairs down the road.

Hydraulic reversing fan

Reversing fan automatically reverses airflow to eject debris from the cooler cores, conserving power and fuel. Variable-speed fan runs only as fast as needed, or if conditions demand more frequent cleaning, simply press a button to actuate the reversing cycle.

Keep it clean

Perforations in the hood and left-side guarding serve as a “first filter,” with the cooler cores providing a backup buffer to loose debris clogging the cooling system.

Proven components

800M- and 800MH-Series machines share many common components — including the engine, undercarriage, booms, and cab — with their 900M- and 900MH-Series counterparts, for ease of maintenance and repairs when needed.

Remote diagnostics

When equipped with JDLink™, fast, accurate remote diagnostics and rapid service response with the right part the first time, industry-leading parts availability, and dealer support are always within easy reach.



***SAVE TIME
AND MONEY.***



803M/853M/859M

Engine	803M/853M/859M					
Manufacturer and Model	John Deere PowerTech™ PSS 9.0L					
Non-Road Emission Standard	EPA Final Tier 4/EU Stage IV					
Cylinders	6					
Displacement	9.0 L (549 cu. in.)					
Peak Power at 1,900 rpm	224 kW (300 hp)					
Rated Power at 2,000 rpm	213 kW (286 hp)					
Net Peak Torque at 1,500 rpm	1270 Nm (937 lb.-ft.)					
Cooling						
Fan Type	Suction type, hydraulically driven, variable speed, reversing					
Hydraulics						
	Closed center, load sense, pressure compensated					
Standard Travel System						
Main Pump	Variable-displacement axial piston					
Maximum Rated Flow	494 L/min. (131 gpm)					
Continuous Saw Pump	Dedicated variable-displacement axial piston					
Maximum Rated Flow	135 L/min. (36 gpm)					
Attachment Pump	Dedicated variable-displacement axial piston					
Maximum Rated Flow	135 L/min. (36 gpm)					
Dedicated Travel						
Main Pump	Variable-displacement axial piston					
Maximum Rated Flow	494 L/min. (131 gpm)					
Travel Pump	Dedicated variable-displacement axial piston					
Maximum Rated Flow (x2)	190 L/min. (50 gpm)					
Continuous Saw Pump	Dedicated variable-displacement axial piston					
Maximum Rated Flow	135 L/min. (36 gpm)					
Attachment Pump	Dedicated variable-displacement axial piston					
Maximum Rated Flow	135 L/min. (36 gpm)					
Oil Filtration	2 main return filters, 10-micron return with bypass, one case drain strainer, 25 micron					
Electrical						
Voltage	24 volt					
Number of Batteries	2 x 12 volt					
Alternator Rating						
Standard	100 amp					
Optional	130 amp					
Work Lights						
Standard	Halogen (9 flood, 3 spot)					
Optional	LED (5 flood, 3 spot); halogen (4 flood)					
Service Lights	Halogen (2)					
Undercarriage	803M	853M		859M		
	Integral track guides, thick high-abrasion-resistant material, ramp angles, hydraulic track adjustment					
Size	U6 Heavy Duty (HD)		U7 Heavy Duty (HD)		U7 Extreme Duty (EXD)	
Track Chain	203.2 mm (8 in.)		215.9 mm (8.5 in.)		215.9 mm (8.5 in.)	
Number of Track Links (per side)	47		47		47	
Lower Rollers (per side)	9		9		10	
Carrier Slides/Rollers (per side)	2		2		2	
Travel Performance	<i>Standard</i>	<i>Dedicated Travel</i>	<i>Standard</i>	<i>Dedicated Travel</i>	<i>Standard</i>	<i>Dedicated Travel</i>
Travel Speed, Forward and Reverse						
High	4.9 km/h (3.0 mph)	4.9 km/h (3.0 mph)	4.2 km/h (2.6 mph)	4.2 km/h (2.6 mph)	3.6 km/h (2.2 mph)	3.6 km/h (2.2 mph)
Low	2.7 km/h (1.7 mph)	2.7 km/h (1.7 mph)	2.1 km/h (1.3 mph)	1.9 km/h (1.2 mph)	1.7 km/h (1.0 mph)	1.6 km/h (1.0 mph)
Tractive Effort	245 kN (55,040 lbf)	245 kN (55,040 lbf)	322 kN (72,300 lbf)	331 kN (74,320 lbf)	373 kN (83,880 lbf)	384 kN (86,210 lbf)
Rotating Upper						
Swing System	<i>Standard</i>	<i>Optional</i>	<i>Standard</i>	<i>Standard</i>		
Swing Speed (maximum)	7.7 rpm	6.8 rpm	6.8 rpm	6.8 rpm		
Swing Torque	55 090 Nm (40,630 lb.-ft.)	94 740 Nm (69,880 lb.-ft.)	94 740 Nm (69,880 lb.-ft.)	94 740 Nm (69,880 lb.-ft.)		
Swing Brake	Sealed wet multi-disc, manually applied/released					
Serviceability	803M/853M/859M					
Refill Capacities						
Fuel Tank	870 L (230 gal.)					
Diesel Exhaust Fluid (DEF)	30.7 L (8.1 gal.)					
Cooling System	41.9 L (11.1 gal.)					
Engine Lubrication (including filter)	31.0 L (8.2 gal.)					
Hydraulic Reservoir Capacity	122 L (32.0 gal.)					



Serviceability (continued) 803M/853M/859M

Refill Capacities (continued)			
Pump Drive Gearbox (dedicated travel only)	6.2 L (1.6 gal.)		
Swing Gearbox (each)	4.5 L (1.2 gal.)		
Track Drive Gearbox (each)	4.8 L (1.3 gal.)		

Ground Pressure (SAE J1309) 803M 853M 859M

Includes standard equipment, standard counterweight, half-full fuel tank, and all fluids, less attachment			
Undercarriage	U6 HD	U7 HD	U7L
Double Grouser			
610 mm (24 in.)	59.3 kPa (8.6 psi)	59.0 kPa (8.6 psi)	69.2 kPa (10.0 psi)
762 mm (30 in.)	48.4 kPa (7.0 psi)	48.3 kPa (7.0 psi)	N/A
Single Grouser			
610 mm (24 in.)	58.8 kPa (8.5 psi)	58.7 kPa (8.5 psi)	68.9 kPa (10.0 psi)
711 mm (28 in.)	51.1 kPa (7.4 psi)	51.1 kPa (7.4 psi)	59.9 kPa (8.7 psi)
Triple Grouser (soft terrain only)			
914 mm (36 in.)	41.3 kPa (6.0 psi)	41.1 kPa (6.0 psi)	N/A

Operating Weight

Includes standard equipment, 610-mm (24 in.) single-grouser tracks, standard counterweight, half-full fuel tank, and all fluids, less attachment			
Undercarriage	U6 HD	U7 HD	U7L
Approximate Weight — Base Machine	28 810 kg (63,530 lb.)	30 710 kg (67,720 lb.)	35 890 kg (79,140 lb.)

Boom Performance

6.71-m Boom

Maximum Reach (to tip of saw blade)	8.49 m (27 ft. 10 in.)	8.49 m (27 ft. 10 in.)	8.49 m (27 ft. 10 in.)
Minimum Reach (to tip of saw blade)	3.83 m (12 ft. 7 in.)	3.83 m (12 ft. 7 in.)	3.83 m (12 ft. 7 in.)
Cutting Swath	4.66 m (15 ft. 3 in.)	4.66 m (15 ft. 3 in.)	4.66 m (15 ft. 3 in.)
Lift Option with RCS			
	<i>Standard</i>	<i>Power</i>	<i>Power</i>
Lift Capacity, Bare Pin at Full Reach	4400 kg (9,700 lb.)	5540 kg (12,220 lb.)	5540 kg (12,220 lb.)
Lift Capacity, Bare Pin at 6.1 m (20 ft.)	5520 kg (12,170 lb.)	6860 kg (15,130 lb.)	6860 kg (15,130 lb.)
Lift Capacity, Bare Pin at 4.6 m (15 ft.)	7990 kg (17,620 lb.)	9770 kg (21,540 lb.)	9770 kg (21,540 lb.)

6.1-m Boom

Maximum Reach (to tip of saw blade)	7.88 m (25 ft. 10 in.)	7.88 m (25 ft. 10 in.)	7.88 m (25 ft. 10 in.)
Minimum Reach (to tip of saw blade)	3.92 m (12 ft. 10 in.)	3.92 m (12 ft. 10 in.)	3.92 m (12 ft. 10 in.)
Cutting Swath	3.96 m (13 ft. 0 in.)	3.96 m (13 ft. 0 in.)	3.96 m (13 ft. 0 in.)
Lift Option with RCS			
	<i>Standard</i>	<i>Power</i>	<i>Power</i>
Lift Capacity, Bare Pin at 6.1 m (20 ft.) at Full Reach	4830 kg (10,650 lb.)	6670 kg (14,710 lb.)	6670 kg (14,710 lb.)
Lift Capacity, Bare Pin at 4.6 m (15 ft.)	7840 kg (17,290 lb.)	10 510 kg (23,170 lb.)	10 510 kg (23,170 lb.)

803M and 853M Tracked Feller Bunchers

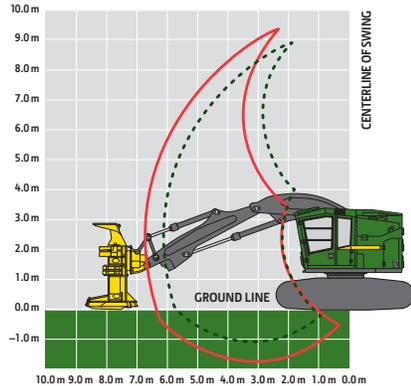

859M Tracked Feller Buncher

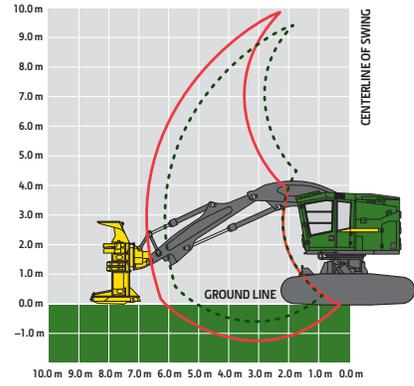

Attachment Information

Attachment Models	FS20	FR21B	FS22B	FR22B	FR24B
Maximum Cutting Capacity	559 mm (22.0 in.)	545 mm (21.5 in.)	559 mm (22.0 in.)	559 mm (22.0 in.)	622 mm (24.5 in.)
Maximum Accumulation Capacity	0.43 m ² (4.6 sq. ft.)	0.46 m ² (5.0 sq. ft.)	0.48 m ² (5.2 sq. ft.)	0.48 m ² (5.2 sq. ft.)	0.60 m ² (6.5 sq. ft.)
Opening at Front of Housing	983 mm (38.7 in.)	1180 mm (46.5 in.)	1280 mm (50.4 in.)	1280 mm (50.4 in.)	1372 mm (54.0 in.)
Blade Diameter	1422 mm (56.0 in.)	1372 mm (54.0 in.)	1422 mm (56.0 in.)	1422 mm (56.0 in.)	1549 mm (61.0 in.)
Number of Teeth	18	18	18	18	20
Saw rpm	1,150 rpm	1,150 rpm	1,150 rpm	1,150 rpm	1,150 rpm
Wrist Rotation	30 deg.	302 deg.	30 deg.	312 deg.	310 deg.
Width at Saw Housing	1600 mm (63.0 in.)	1550 mm (61.0 in.)	1620 mm (63.8 in.)	1620 mm (63.8 in.)	1737 mm (68.4 in.)
Height	2794 mm (110.0 in.)	2820 mm (111.0 in.)	3068 mm (120.8 in.)	3068 mm (120.8 in.)	3068 mm (120.8 in.)
Weight (including adapter and wrist)	2650 kg (5,840 lb.)	3140 kg (6,920 lb.)	3550 kg (7,830 lb.)	3840 kg (8,470 lb.)	4020 kg (8,860 lb.)

803M/853M/859M

Machine Dimensions	803M	853M	859M
Standard Undercarriage	U6 HD	U7 HD	U7L EXD
A Overall Height with Standard 6.71-m Boom			
Top of Cab with Flat Skylight	3.43 m (11 ft. 3 in.)	3.46 m (11 ft. 4 in.)	3.92 m (12 ft. 10 in.)
Top of Cab with Peaked Skylight	3.65 m (12 ft. 0 in.)	3.68 m (12 ft. 1 in.)	4.13 m (13 ft. 7 in.)
Top of Boom, Extended, Attachment Vertical	3.89 m (12 ft. 9 in.)	3.93 m (12 ft. 11 in.)	4.15 m (13 ft. 7 in.)
B Overall Track Length	4.61 m (15 ft. 1 in.)	4.90 m (16 ft. 1 in.)	4.90 m (16 ft. 1 in.)
C Track Length (idler to sprocket center)	3.57 m (11 ft. 9 in.)	3.83 m (12 ft. 7 in.)	3.83 m (12 ft. 7 in.)
D Tail Swing (from swing center)			
Small and Medium Counterweight	1.94 m (6 ft. 4 in.)	1.94 m (6 ft. 4 in.)	1.94 m (6 ft. 4 in.)
Medium Extended and Large Extended Counterweight	2.25 m (7 ft. 4 in.)	2.25 m (7 ft. 4 in.)	2.25 m (7 ft. 4 in.)
E Boom Reach (to attachment pin)			
Standard 6.71-m Boom			
Maximum	6.71 m (22 ft. 0 in.)	6.71 m (22 ft. 0 in.)	6.71 m (22 ft. 0 in.)
Minimum	2.05 m (6 ft. 9 in.)	2.05 m (6 ft. 9 in.)	2.05 m (6 ft. 9 in.)
Cutting Swath	4.66 m (15 ft. 3 in.)	4.66 m (15 ft. 3 in.)	4.66 m (15 ft. 3 in.)
Optional 6.10-m Boom			
Maximum	6.10 m (20 ft. 0 in.)	6.10 m (20 ft. 0 in.)	6.10 m (20 ft. 0 in.)
Minimum	2.14 m (7 ft. 0 in.)	2.14 m (7 ft. 0 in.)	2.14 m (7 ft. 0 in.)
Cutting Swath	3.96 m (13 ft. 0 in.)	3.96 m (13 ft. 0 in.)	3.96 m (13 ft. 0 in.)
F Ground Clearance			
Single Grouser	744 mm (29 in.)	779 mm (31 in.)	746 mm (29 in.)
Double Grouser	715 mm (28 in.)	756 mm (30 in.)	722 mm (28 in.)
Triple Grouser	700 mm (28 in.)	738 mm (29 in.)	N/A
G Upperstructure Width			
Standard	3.15 m (10 ft. 4 in.)	3.15 m (10 ft. 4 in.)	3.15 m (10 ft. 4 in.)
With Optional Walkway	3.36 m (11 ft. 0 in.)	3.36 m (11 ft. 0 in.)	3.36 m (11 ft. 0 in.)
H Track Gauge	2.67 m (8 ft. 9 in.)	2.69 m (8 ft. 10 in.)	2.72 m (8 ft. 11 in.)
I Width Over Tracks			
610-mm (24 in.) Track Shoes	3.28 m (10 ft. 9 in.)	3.30 m (10 ft. 10 in.)	3.33 m (10 ft. 11 in.)
711-mm (28 in.) Track Shoes	3.38 m (11 ft. 1 in.)	3.40 m (11 ft. 2 in.)	3.43 m (11 ft. 3 in.)
760-mm (30 in.) Track Shoes	3.43 m (11 ft. 3 in.)	3.45 m (11 ft. 4 in.)	N/A
914-mm (36 in.) Track Shoes	3.58 m (11 ft. 9 in.)	3.61 m (11 ft. 10 in.)	N/A

859M Leveling

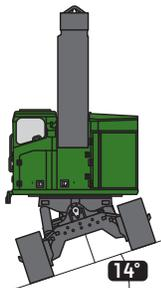
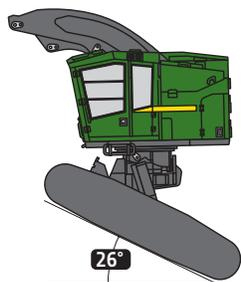

859M Undercarriage-Leveling Mechanism

Forward	26 deg.
Side to Side	14 deg.
Rearward	7 deg.

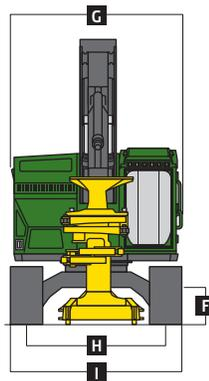

803M/853M Tracked Feller Bunchers

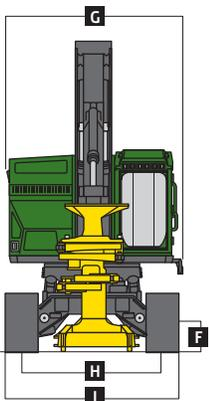
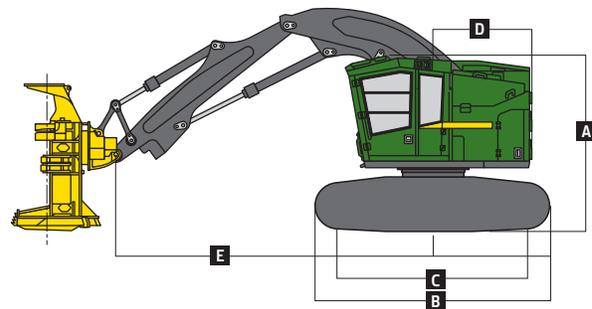

859M Tracked Feller Buncher

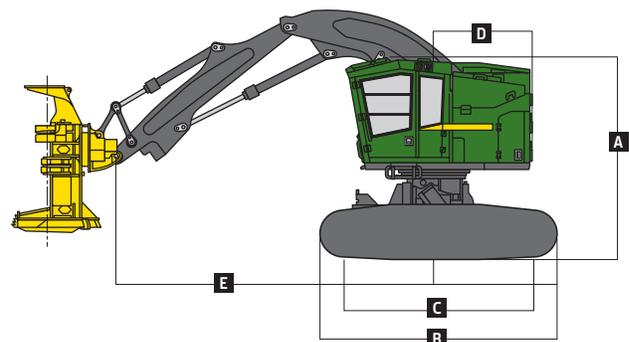

Machine not exactly as shown. Illustrations for dimensioning purposes only. Specifications are subject to change without notice.

803MH/853MH/859MH

Engine	803MH/853MH/859MH					
Manufacturer and Model	John Deere PowerTech™ PSS 9.0L					
Non-Road Emission Standard	EPA Final Tier 4/EU Stage IV					
Cylinders	6					
Displacement	9.0 L (549 cu. in.)					
Peak Power at 1,900 rpm	224 kW (300 hp)					
Rated Power at 2,000 rpm	213 kW (286 hp)					
Net Peak Torque at 1,500 rpm	1270 Nm (937 lb.-ft.)					
Cooling						
Fan Type	Suction type, hydraulically driven, variable speed, reversing					
Hydraulics						
Closed center, load sense, pressure compensated						
Standard Travel System						
Main Pump	Variable-displacement axial piston					
Maximum Rated Flow	494 L/min. (131 gpm)					
Attachment Pump	Dedicated variable-displacement axial piston					
Maximum Rated Flow (x2)	135 L/min. (36 gpm)					
Dedicated Travel						
Main Pump	Variable-displacement axial piston					
Maximum Rated Flow	494 L/min. (131 gpm)					
Travel Pump	Dedicated variable-displacement axial piston					
Maximum Rated Flow (x2)	190 L/min. (50 gpm)					
Attachment Pump	Dedicated variable-displacement axial piston					
Maximum Rated Flow (x2)	135 L/min. (36 gpm)					
Oil Filtration	2 main return filters, 10-micron return with bypass, one case drain strainer, 25 micron					
Electrical						
Voltage	24 volt					
Number of Batteries	2 x 12 volt					
Alternator Rating						
Standard	100 amp					
Optional	130 amp					
Work Lights						
Standard	Halogen (9 flood, 3 spot)					
Optional	LED (5 flood, 3 spot); halogen (4 flood)					
Service Lights	Halogen (2)					
Undercarriage	803MH	853MH		859MH		
Integral track guides, thick high-abrasion-resistant material, ramp angles, hydraulic track adjustment						
Size	U6 Heavy Duty (HD)		U7 Heavy Duty (HD)		U7 Extreme Duty (EXD)	
Track Chain	203.2 mm (8 in.)		215.9 mm (8.5 in.)		215.9 mm (8.5 in.)	
Number of Track Links (per side)	47		47		47	
Lower Rollers (per side)	9		9		10	
Carrier Slides/Rollers (per side)	2		2		2	
Travel Performance	<i>Standard</i>	<i>Dedicated Travel</i>	<i>Standard</i>	<i>Dedicated Travel</i>	<i>Standard</i>	<i>Dedicated Travel</i>
Travel Speed, Forward and Reverse						
High	4.9 km/h (3.0 mph)	4.9 km/h (3.0 mph)	4.2 km/h (2.6 mph)	4.2 km/h (2.6 mph)	3.6 km/h (2.2 mph)	3.6 km/h (2.2 mph)
Low	2.7 km/h (1.7 mph)	2.7 km/h (1.7 mph)	2.1 km/h (1.3 mph)	1.9 km/h (1.2 mph)	1.7 km/h (1.0 mph)	1.6 km/h (1.0 mph)
Tractive Effort	245 kN (55,040 lbf)	245 kN (55,040 lbf)	322 kN (72,300 lbf)	331 kN (74,320 lbf)	373 kN (83,880 lbf)	384 kN (86,210 lbf)
Rotating Upper	803MH/853MH/859MH					
Swing System, Standard						
Swing Speed (maximum)	6.8 rpm					
Swing Torque	94 740 Nm (69,880 lb.-ft.)					
Swing Brake	Sealed wet multi-disc, manually applied/released					
Serviceability						
Refill Capacities						
Fuel Tank	870 L (230 gal.)					
Diesel Exhaust Fluid (DEF)	30.7 L (8.1 gal.)					
Cooling System	41.9 L (11.1 gal.)					
Engline Lubrication (including filter)	31.0 L (8.2 gal.)					
Hydraulic Reservoir Capacity	122 L (32.0 gal.)					
Pump Drive Gearbox (dedicated travel only)	6.2 L (1.6 gal.)					
Swing Gearbox (each)	4.5 L (1.2 gal.)					
Track Drive Gearbox (each)	4.8 L (1.3 gal.)					

803MH/853MH/859MH

Ground Pressure (SAE J1309)	803MH	853MH	859MH
Includes standard equipment, standard counterweight, half-full fuel tank, and all fluids, less attachment			
Undercarriage	U6 HD	U7 HD	U7L EXD
Double Grouser			
610 mm (24 in.)	59.1 kPa (8.6 psi)	58.6 kPa (8.5 psi)	68.9 kPa (10.0 psi)
762 mm (30 in.)	48.2 kPa (7.0 psi)	48.0 kPa (7.0 psi)	N/A
Single Grouser			
610 mm (24 in.)	58.6 kPa (8.5 psi)	58.4 kPa (8.5 psi)	68.4 kPa (9.9 psi)
711 mm (28 in.)	50.9 kPa (7.4 psi)	50.8 kPa (7.4 psi)	59.0 kPa (8.6 psi)
Triple Grouser (soft terrain only)			
914 mm (36 in.)	41.1 kPa (6.0 psi)	40.8 kPa (5.9 psi)	N/A

Operating Weight			
Includes standard equipment, 610-mm (24 in.) single-grouser tracks, standard counterweight, half-full fuel tank, and all fluids, less attachment			
Undercarriage	U6 HD	U7 HD	U7L EXD
Approximate Weight — Base Machine	28 710 kg (63,310 lb.)	30 530 kg (67,320 lb.)	35 780 kg (78,890 lb.)

Boom Performance			
8.84-m Boom with RCS			
Maximum Reach (to attachment pin)	8.84 m (29 ft. 0 in.)	8.84 m (29 ft. 0 in.)	8.84 m (29 ft. 0 in.)
Minimum Reach (to attachment pin)	2.71 m (8 ft. 11 in.)	2.71 m (8 ft. 11 in.)	2.71 m (8 ft. 11 in.)
Harvesting Swath	6.13 m (20 ft. 1 in.)	6.13 m (20 ft. 1 in.)	6.13 m (20 ft. 1 in.)
Standard-Lift Option			
Lift Capacity, Bare Pin at Full Reach	4190 kg (9,240 lb.)	4190 kg (9,240 lb.)	4190 kg (9,240 lb.)
Lift Capacity, Bare Pin at 7.62 m (25 ft.)	5850 kg (12,900 lb.)	5850 kg (12,900 lb.)	5850 kg (12,900 lb.)
Lift Capacity, Bare Pin at 6.1 m (20 ft.)	7700 kg (16,980 lb.)	7700 kg (16,980 lb.)	7700 kg (16,980 lb.)
7.75-m Boom with RCS			
Maximum Reach (to attachment pin)	7.75 m (25 ft. 5 in.)	7.75 m (25 ft. 5 in.)	7.75 m (25 ft. 5 in.)
Minimum Reach (to attachment pin)	2.31 m (7 ft. 7 in.)	2.31 m (7 ft. 7 in.)	2.31 m (7 ft. 7 in.)
Harvesting Swath	5.44 m (17 ft. 10 in.)	5.44 m (17 ft. 10 in.)	5.44 m (17 ft. 10 in.)
Standard-Lift Option			
Lift Capacity, Bare Pin at 7.62 m (25 ft.) at Full Reach	5520 kg (12,170 lb.)	5520 kg (12,170 lb.)	5520 kg (12,170 lb.)
Lift Capacity, Bare Pin at 6.1 m (20 ft.)	8350 kg (18,410 lb.)	8350 kg (18,410 lb.)	8350 kg (18,410 lb.)

803MH and 853MH Tracked Harvesters

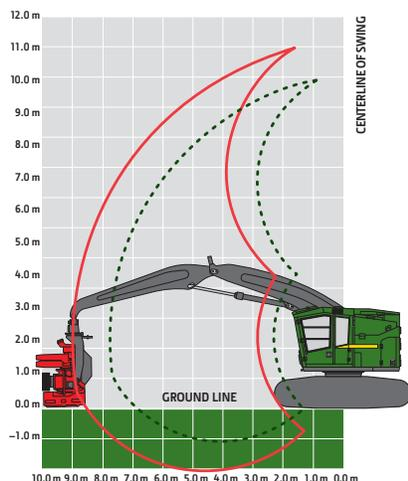

859MH Tracked Harvester

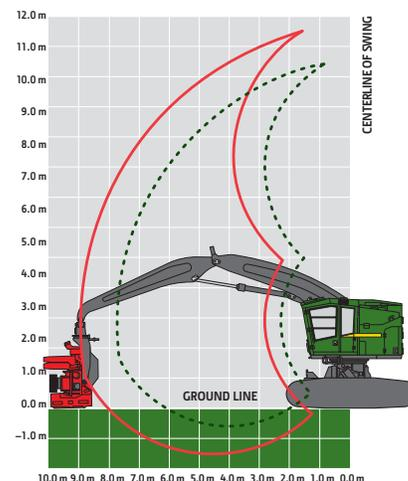

Attachment Information				
Attachment	HTH616C	HTH622B	HTH623C	HTH624C
Models	803MH, 853MH, 859MH	803MH, 853MH, 859MH	803MH, 853MH, 859MH	853MH, 859MH
Maximum Cutting Capacity	550 mm (21.7 in.)	750 mm (29.5 in.)	750 mm (29.5 in.)	810 mm (31.9 in.)
Maximum Delimiting Capacity	510 mm (20.1 in.)	640 mm (25.2 in.)	700 mm (27.6 in.)	760 mm (29.9 in.)
Feeding Mechanism	3 rollers, fully synchronized hydraulic drive		3 rollers, fully synchronized hydraulic drive	
Dimensions				
Maximum Width (arms open)	1600 mm (63.0 in.)	1700 mm (66.9 in.)	2000 mm (78.7 in.)	2000 mm (78.7 in.)
Height (including rotator)	2350 mm (92.5 in.)	2700 mm (106.3 in.)	3000 mm (118.1 in.)	3000 mm (118.1 in.)
Weight (rotator and standard link)	1870 kg (4,120 lb.)	2190 kg (4,830 lb.)	2870 kg (6,330 lb.)	3460 kg (7,630 lb.)

(See individual Harvesting Head brochure for more details.)

Machine not exactly as shown. Illustrations for dimensioning purposes only. Specifications are subject to change without notice.

803MH/853MH/859MH

Machine Dimensions	803MH	853MH	859MH
Standard Undercarriage	U6 HD	U7 HD	U7L EXD
A Overall Height with 8.84-m Boom			
Top of Cab with Flat Skylight	3.43 m (11 ft. 3 in.)	3.46 m (11 ft. 4 in.)	3.92 m (12 ft. 10 in.)
Top of Cab with Peaked Skylight	3.65 m (12 ft. 0 in.)	3.68 m (12 ft. 1 in.)	4.13 m (13 ft. 7 in.)
Top of Boom, Extended, Attachment Vertical	4.45 m (14 ft. 7 in.)	4.45 m (14 ft. 7 in.)	4.70 m (15 ft. 5 in.)
B Overall Track Length	4.61 m (15 ft. 1 in.)	4.90 m (16 ft. 1 in.)	4.90 m (16 ft. 1 in.)
C Track Length (idler to sprocket center)	3.57 m (11 ft. 9 in.)	3.83 m (12 ft. 7 in.)	3.83 m (12 ft. 7 in.)
D Tail Swing (from swing center)			
Small and Medium Counterweight	1.94 m (6 ft. 4 in.)	1.94 m (6 ft. 4 in.)	1.94 m (6 ft. 4 in.)
Medium Extended Counterweight	2.25 m (7 ft. 4 in.)	2.25 m (7 ft. 4 in.)	2.25 m (7 ft. 4 in.)
E Boom Reach (to attachment pin)			
Standard 8.84-m Boom			
Maximum	8.84 m (29 ft. 0 in.)	8.84 m (29 ft. 0 in.)	8.84 m (29 ft. 0 in.)
Minimum	2.71 m (8 ft. 11 in.)	2.71 m (8 ft. 11 in.)	2.71 m (8 ft. 11 in.)
Cutting Swath	6.13 m (20 ft. 1 in.)	6.13 m (20 ft. 1 in.)	6.13 m (20 ft. 1 in.)
Optional 7.75-m Boom			
Maximum	7.75 m (25 ft. 5 in.)	7.75 m (25 ft. 5 in.)	7.75 m (25 ft. 5 in.)
Minimum	2.31 m (7 ft. 7 in.)	2.31 m (7 ft. 7 in.)	2.31 m (7 ft. 7 in.)
Cutting Swath	5.44 m (17 ft. 10 in.)	5.44 m (17 ft. 10 in.)	5.44 m (17 ft. 10 in.)
F Ground Clearance			
Single Grouser	744 mm (29 in.)	779 mm (31 in.)	748 mm (29 in.)
Double Grouser	715 mm (28 in.)	756 mm (30 in.)	725 mm (29 in.)
Triple Grouser	700 mm (28 in.)	738 mm (29 in.)	N/A
G Upperstructure Width			
Standard	3.15 m (10 ft. 4 in.)	3.15 m (10 ft. 4 in.)	3.15 m (10 ft. 4 in.)
With Optional Walkway	3.36 m (11 ft. 0 in.)	3.36 m (11 ft. 0 in.)	3.36 m (11 ft. 0 in.)
H Track Gauge	2.67 m (8 ft. 9 in.)	2.69 m (8 ft. 10 in.)	2.72 m (8 ft. 11 in.)
I Width Over Tracks			
610-mm (24 in.) Track Shoes	3.28 m (10 ft. 9 in.)	3.30 m (10 ft. 10 in.)	3.33 m (10 ft. 11 in.)
711-mm (28 in.) Track Shoes	3.38 m (11 ft. 1 in.)	3.40 m (11 ft. 2 in.)	3.43 m (11 ft. 3 in.)
760-mm (30 in.) Track Shoes	3.43 m (11 ft. 3 in.)	3.45 m (11 ft. 4 in.)	N/A
914-mm (36 in.) Track Shoes	3.58 m (11 ft. 9 in.)	3.61 m (11 ft. 10 in.)	N/A

859MH Leveling

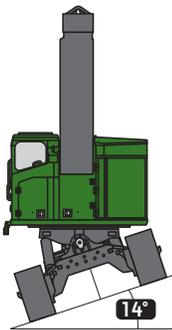
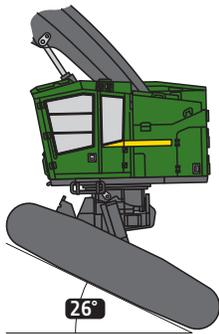

859MH Undercarriage-Leveling Mechanism

Forward	26 deg.
Side to Side	14 deg.
Rearward	7 deg.

803MH/853MH Tracked Harvesters

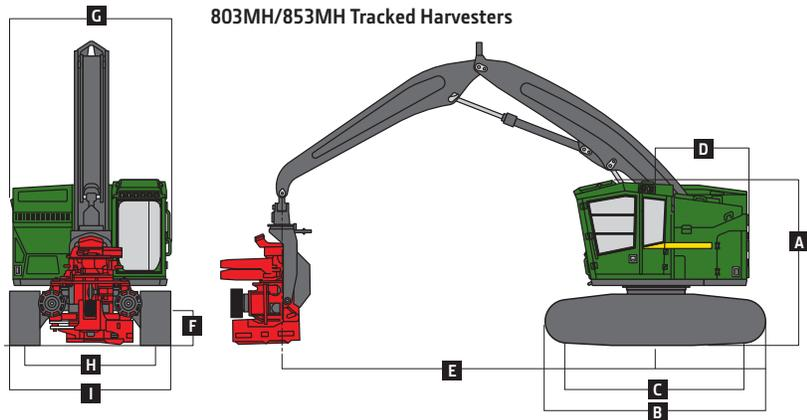

859MH Tracked Harvester

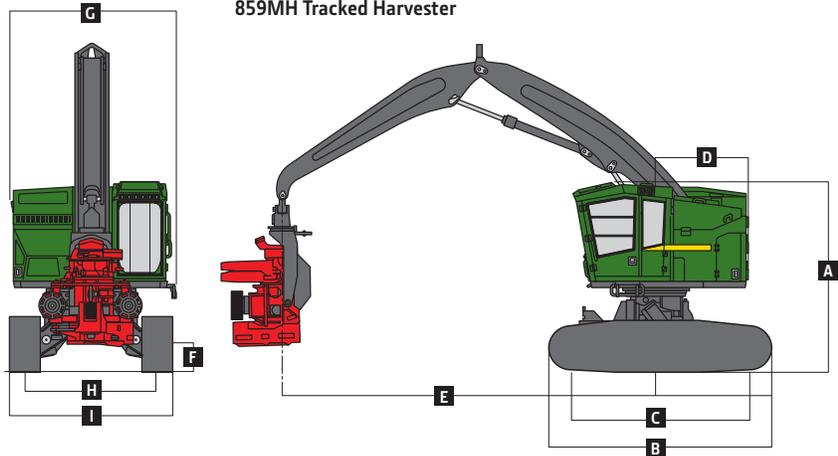



JOHN DEERE

JohnDeere.com/forestry

TO FIND SUCCESS IN THE FOREST,
YOU CAN WAIT FOR THE PERFECT SET OF CONDITIONS.
Or give yourself every advantage to create your own.
Productive machines. Useful insights. Dependable support.
A full set of solutions that only one partner can provide.

The obstacles to success are many. John Deere helps you
OUTRUN™ THEM ALL.