

ALLTERR[®]

オルター[®]

KA-2000

●オルターは、KATOの登録商標です。

【主要諸元】

■クレーン部

型 式 カトウKA-2000型 全油圧式オールテレーンクレーン

●クレーン容量

ブーム	アウトリガ使用 全周
	200t × 3.0m 13.6m ブーム
	120t × 6.0m 18.15m ブーム
	120t × 5.0m 22.7m ブーム
	65t × 10.0m 31.8m ブーム
	60t × 9.0m 40.9m ブーム
35t × 12.0m 50.0m ブーム	
11.4t × 34.0m ルースタシーブ	
スーパーラフティングジブ	アウトリガ使用
	22t × 16m(40.9mブーム+10.5m S Lジブ)
	10t × 26m(40.9mブーム+18.9m S Lジブ)
	6.5t × 28m(40.9mブーム+27.3m S Lジブ)
	17t × 18m(50.0mブーム+10.5m S Lジブ)
	9.5t × 28m(50.0mブーム+18.9m S Lジブ)
6t × 34m(50.0mブーム+27.3m S Lジブ)	
ヘビーリフトジブ	アウトリガ使用
	84t × 6m(13.6mブーム+12mヘビーリフトジブ)
	55.5t × 9m(13.6mブーム+21mヘビーリフトジブ)
	33t × 14m(13.6mブーム+30mヘビーリフトジブ)
	11t × 40m(31.8mブーム+40mヘビーリフトジブ)
	7.5t × 34m(31.8mブーム+47mヘビーリフトジブ)
3.8t × 40m(40.9mブーム+54mヘビーリフトジブ)	
ブーム長さ	13.6m~50m(伸縮式)
S Lジブ長さ	10.5m~27.3m
ヘビーリフトジブ長さ	12m, 21m, 30m, 40m, 47m, 54m
最大地上揚程	50m(ブーム) 79m(S Lジブ) 106m(ヘビーリフトジブ)
巻上ロープ速度	主巻 90m/min(3層目) (高速)125m/min 補巻 90m/min(3層目) (高速)125m/min
ブーム起伏範囲	-2°~83°
ブーム上げ時間	81sec / -2°~83°
旋回速度	1.3 rpm

●エンジン

名 称	ニッサンディーゼル RE804
型 式	水冷4サイクル V8 直接噴射式ディーゼルエンジン
定 格 出 力	260 PS / 1,950 rpm
最大トルク	100 kgf-m / 1,400 rpm
燃料タンク容量	300 ℓ

●油圧装置

オイルポンプ	2連斜軸型バリエブルピストンポンプ+3連ギヤ型ポンプ
巻上用オイルモータ	斜板型バリエブルピストンモータ
旋回用オイルモータ	斜板型ピストンモータ
コントロールバルブ	マルチプル自動復元式(圧力補償付流量調整弁付)
シリンダ	高圧ダブルアクティング式
オイルリザーバ	1,500 ℓ

●上部旋回体の装置及び構造

ブーム	5段ブーム 全段油圧伸縮式
S Lジブ	3段ジブ油圧ワイヤロープ併用伸縮式(2~3段同時)
巻上装置	オイルモータ駆動遊星歯車及び平歯車減速式(高低切換装置・自動ブレーキ付) シングルウィンチ2基
旋回装置	オイルモータ駆動遊星歯車減速式(ディスクブレーキ内蔵 フリー・ロック切換式)
旋回サークル	3列ローラー式
ブーム起伏装置	油圧シリンダ直押し式
ブーム伸縮装置	油圧シリンダ式
アウトリガ装置	油圧垂直支持式(サイドサポート付)
アウトリガ張出幅	9.4m・8.6m・7.2m・5.4m 4位置
パイロットウィンチ	オイルモータ駆動式 ロープ 6×19 φ5×52.5m
ロープ	主巻 タフナフレックス φ24×370m 補巻 タフナフレックス φ24×370m
フック	200/150t ロープ掛数 22/12 65t ロープ掛数 6 22t ロープ掛数 2 11.4t ロープ掛数 1
カウンタウエイト着脱装置	ダブルアクティングシリンダ駆動特殊リンク式 メカニカルロック付カウンタウエイト 60ton(分割式)

●安全装置

	A C S (全自動過負荷防止装置)、アウトリガ張出幅自動検出装置、旋回位置検出装置、ブーム自然降下防止装置、過巻防止装置、ドラムロック装置、ドラムホールド安全装置、ドラム回転計、自動ブレーキ装置、乱巻防止装置、油圧安全弁、アウトリガロック装置、角度指示器、A C S 外部表示灯、音声旋回警報装置
--	---

●標準装置

	クレーン・キャリア運転室エアコン、AM/FMラジオ、オートオイルクーラ、リモコン式サーチライト
--	---

■キャリア部

型 式	日産ディーゼル KC-AL630YN	
全 長	14,360 mm	
全 幅	3,000 mm	
全 高	2,870 mm	
車両総重量	44,950 kg	
軸 距	2,770+1,950+1,650+1,700+1,650=9,720 mm	
輪 距	前 輪	2,510 mm
	後 輪	2,510 mm
エンジン名称	日産ディーゼル RH10	
エンジン型式	水冷4サイクル V10	
総排気量	26,507 ℓ	
最大出力	450PS/2,200rpm (JIS)	
最大トルク	160kg-m/1,400rpm (JIS)	
最高速度	60 km/h	
登坂能力(tanθ)	0.34(車両総重量44,950 kg時)	
最小回転半径	11.6 m	
燃料タンク容量	300 ℓ	
タイヤ	前 輪	445/95 R 25 177E ROAD
	後 輪	445/95 R 25 177E ROAD
乗 員	2名	

【注意】

- 1.) 本機は公道を走行する場合、旋回体及びブームを別送し台車のみで走行しなければなりません。
- 2.) 道路法による基本通行条件のC条件適合車です。
- 3.) 道路を通行する場合には、道路法により通行の許可と道路運送車両法による保安基準の緩和が必要です。
- 4.) 構内を移動する時に限り構内走行姿勢図のような状態で移動できます。但し、走行速度は25km/h以下で走行してください。
- 5.) クレーンの旋回体にカウンタウエイトを装着している時は、必ずアウトリガを使用した状態にしてください。
- 6.) アウトリガははっぱいに張出し、サイドサポートをセットすることを基本とします。
- 7.) 本カタログに記載されております性能ならびに仕様は、改良などによりお届けいたします製品と異なる場合がありますので、あらかじめご了承ください。
- 8.) 本機の使用にあたっては、取り扱い説明書の内容をよく読んで、正しくお使いください。

■主要寸法

クレーン吊钩
2-83-2
吊钩位置

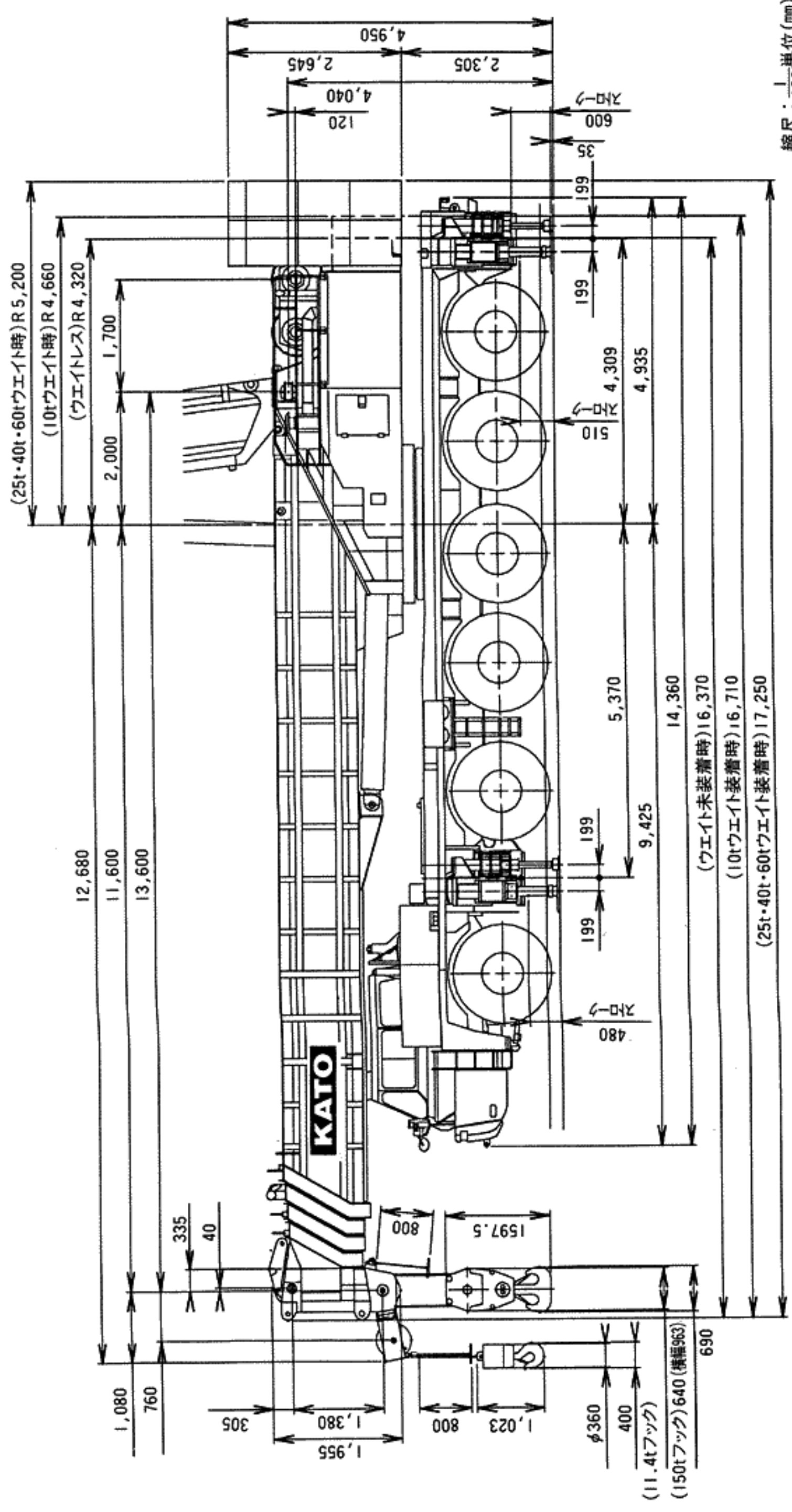

■構内走行外観寸法

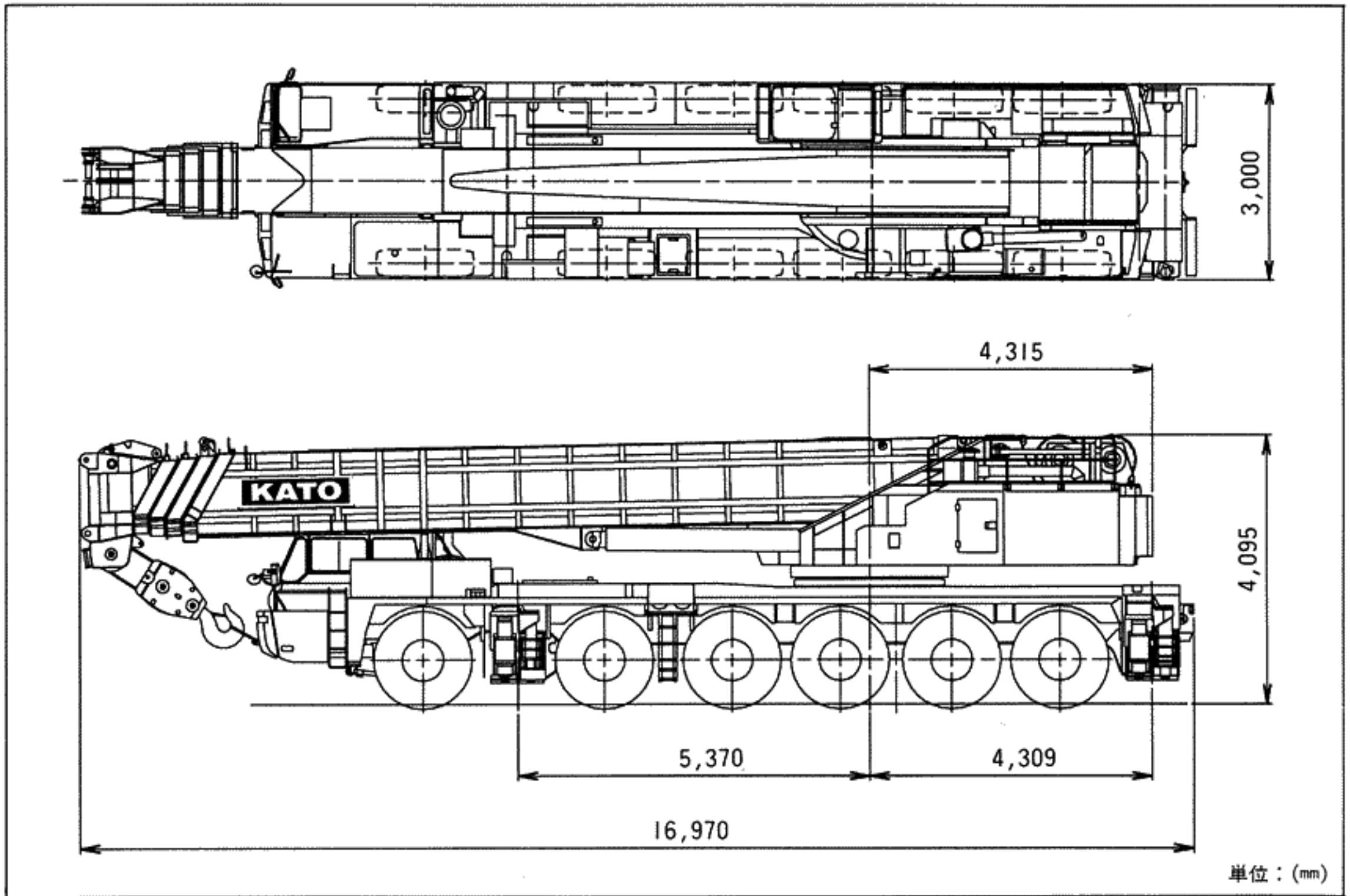

■公道走行、台車寸法

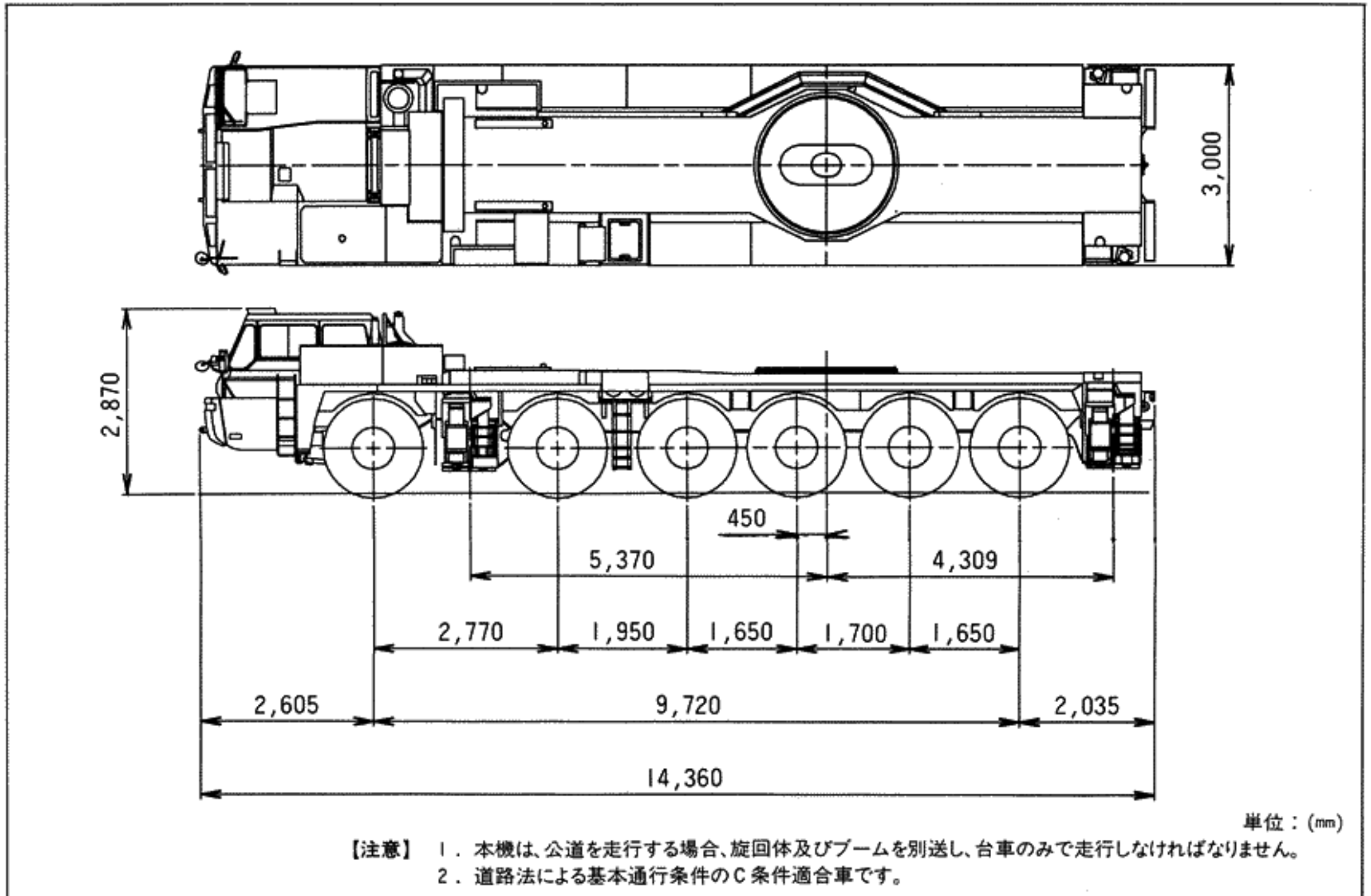

■アウトリガ張出し寸法

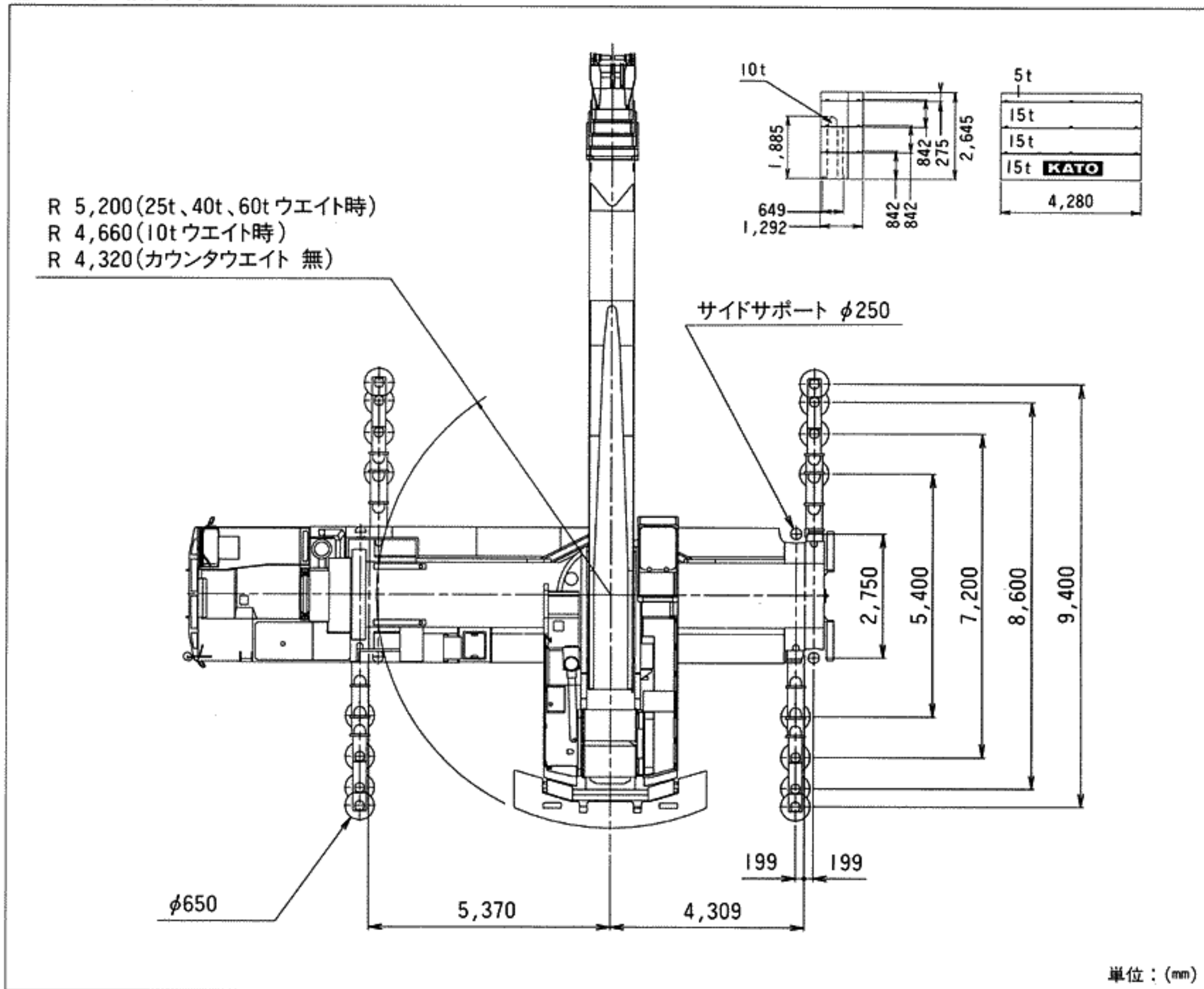

■最小直角道路幅(構内走行姿勢)

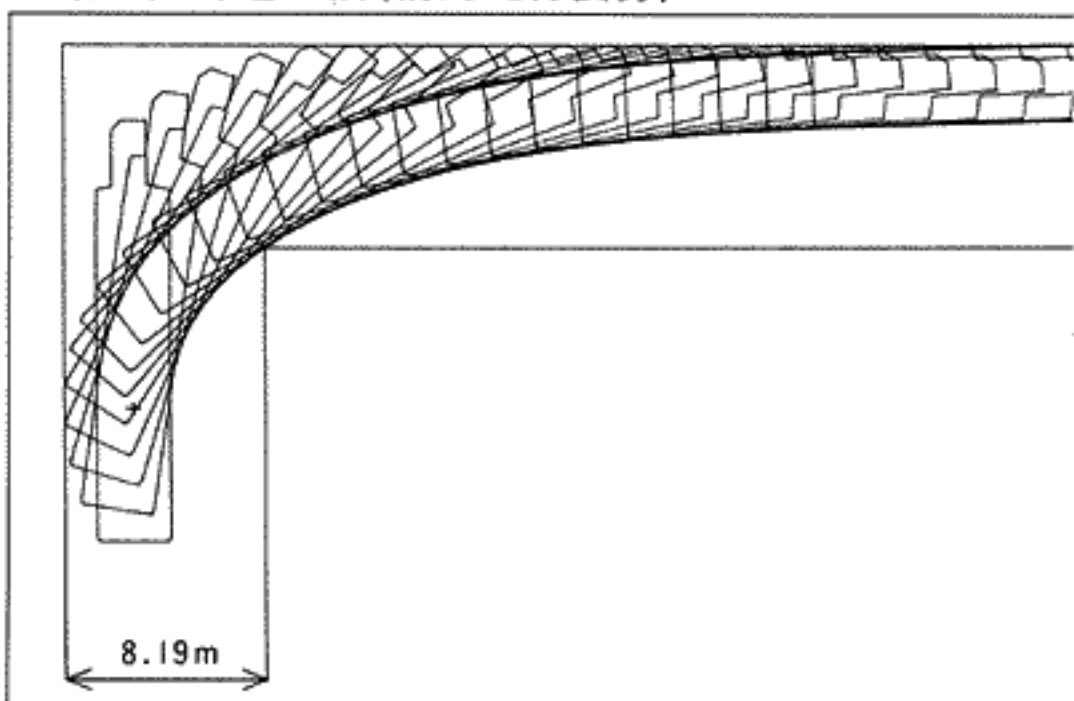

■小人数で短時間でスピーディにできるカトウ独自の脱着方式

1.) 台車部からブームと旋回体をきり離し、台車部は自車で走行移動



2.) 旋回体からブームをきり離し、旋回体をトレーラで搬送



3.) ブームはトレーラで搬送

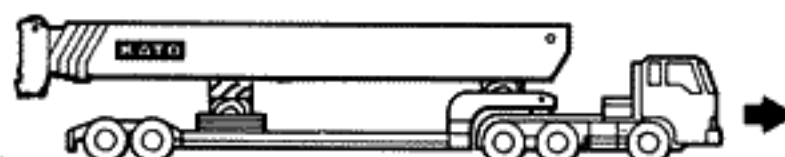

■ヘビーリフトジブ 振出しおよび作業姿勢

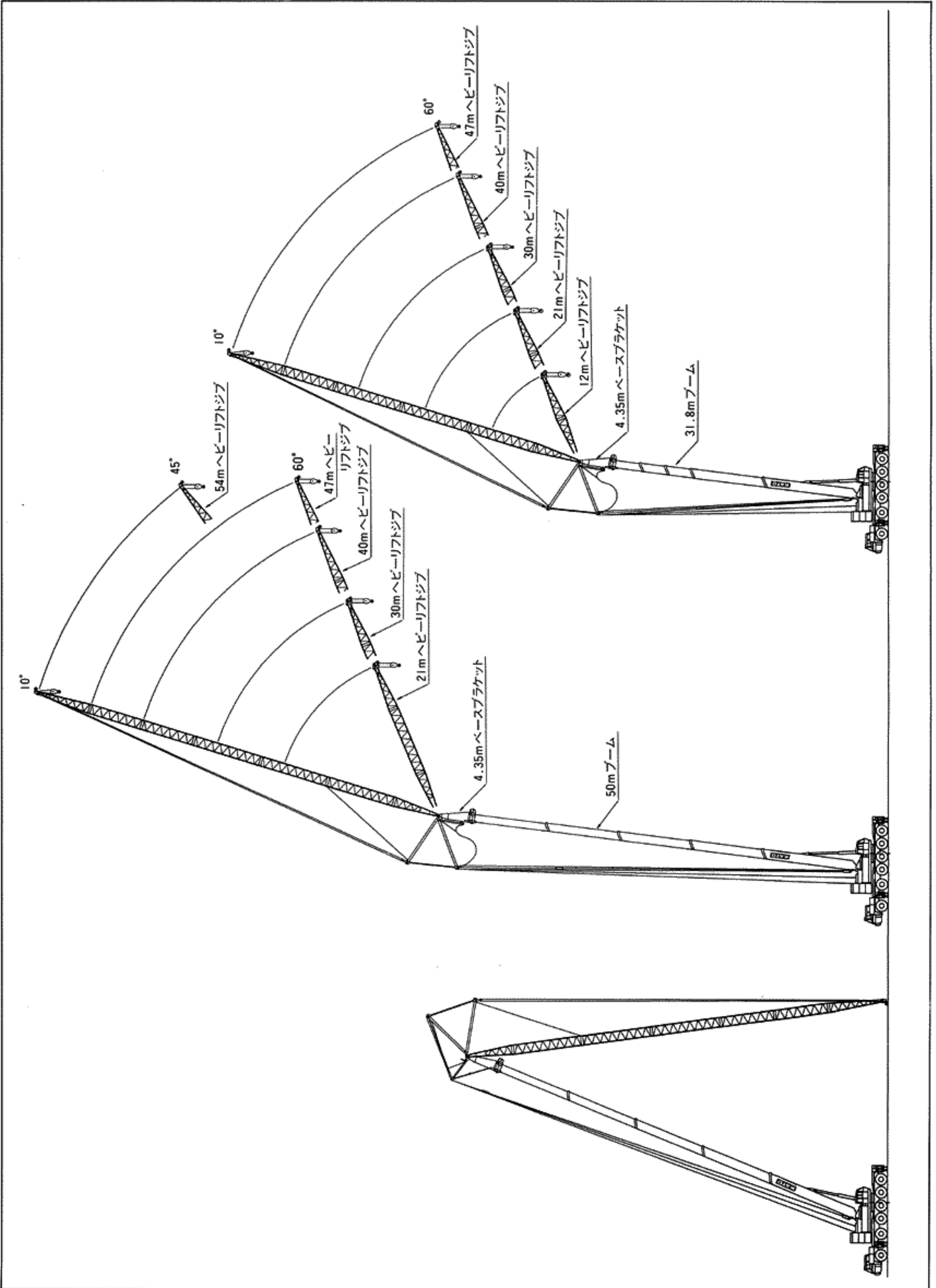

ブーム

■作業半径揚程図

- ① 13.6mブーム
- ② 18.15mブーム
- ③ 22.7mブーム
- ④ 31.8mブーム
- ⑤ 40.9mブーム
- ⑥ 50.0mブーム
- ⑦ 13.6mブーム+ルースタシブ
- ⑧ 18.15mブーム+ルースタシブ
- ⑨ 22.7mブーム+ルースタシブ
- ⑩ 31.8mブーム+ルースタシブ
- ⑪ 40.9mブーム+ルースタシブ
- ⑫ 50.0mブーム+ルースタシブ

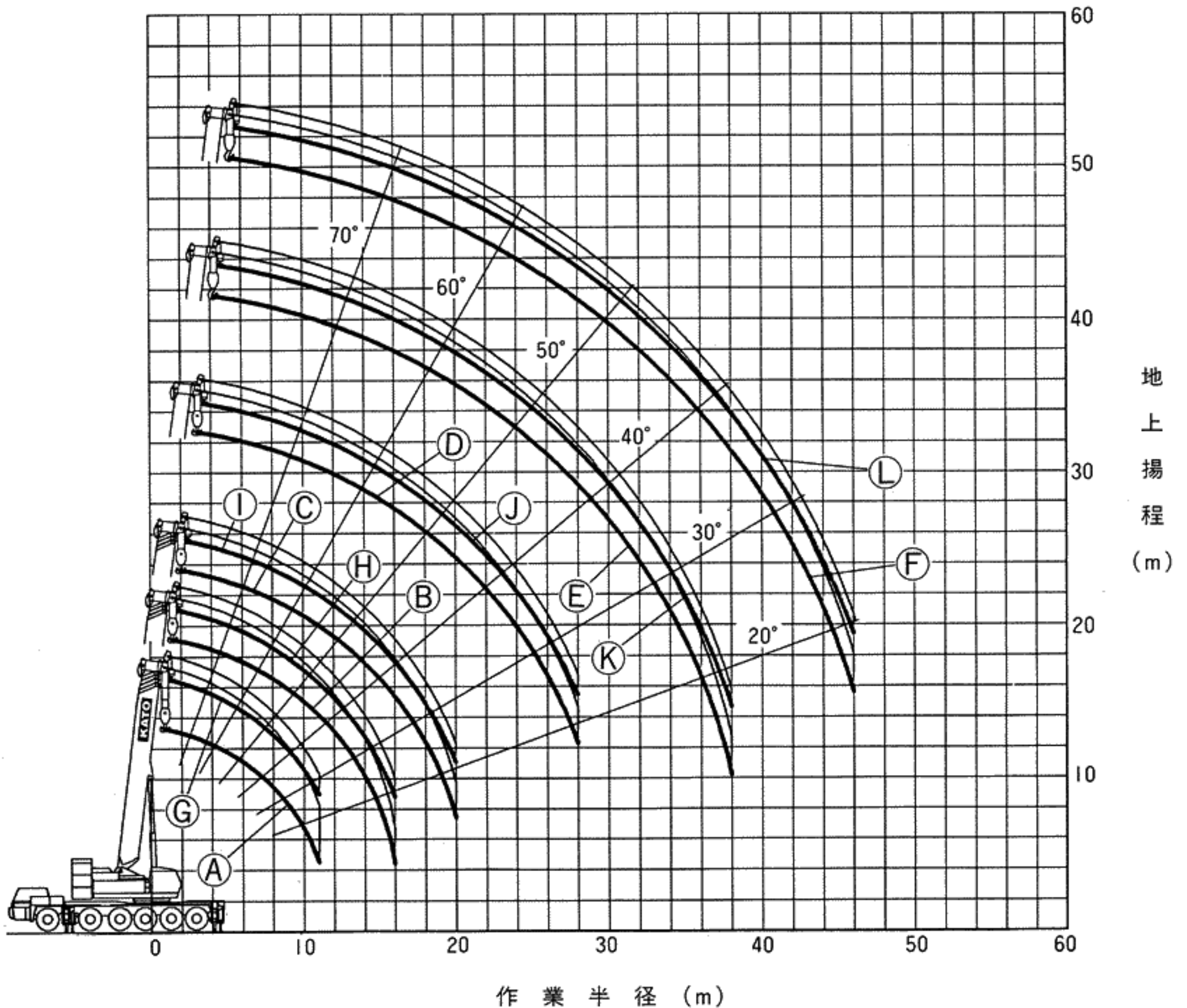
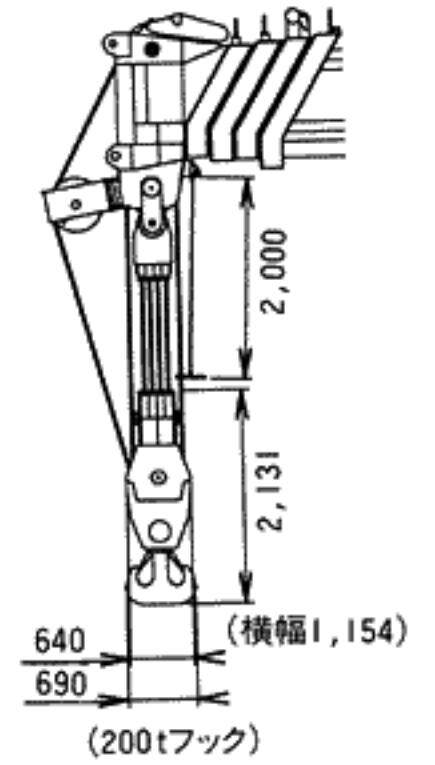
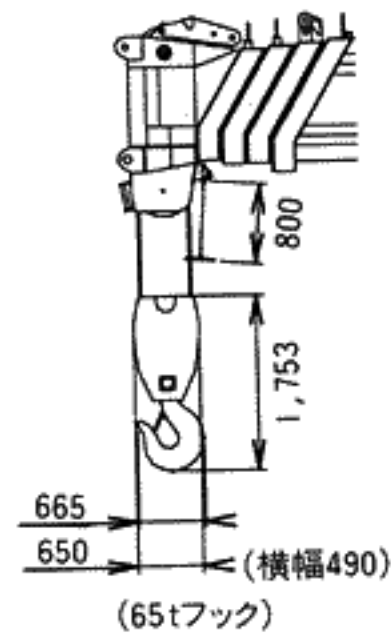

注) 本図は、ブームのたわみを含んでいません。

スーパーラフィングジブ(SLジブ)

■作業半径揚程図

40.9mブーム+10.5m~27.3mSLジブ

- Ⓐ 40.9mブーム+10.5mSLジブ(オフセット0°)
- Ⓑ 40.9mブーム+18.9mSLジブ(オフセット0°)
- Ⓒ 40.9mブーム+27.3mSLジブ(オフセット0°)
- Ⓓ 40.9mブーム+10.5mSLジブ(オフセット60°)
- Ⓔ 40.9mブーム+18.9mSLジブ(オフセット60°)
- Ⓕ 40.9mブーム+27.3mSLジブ(オフセット60°)

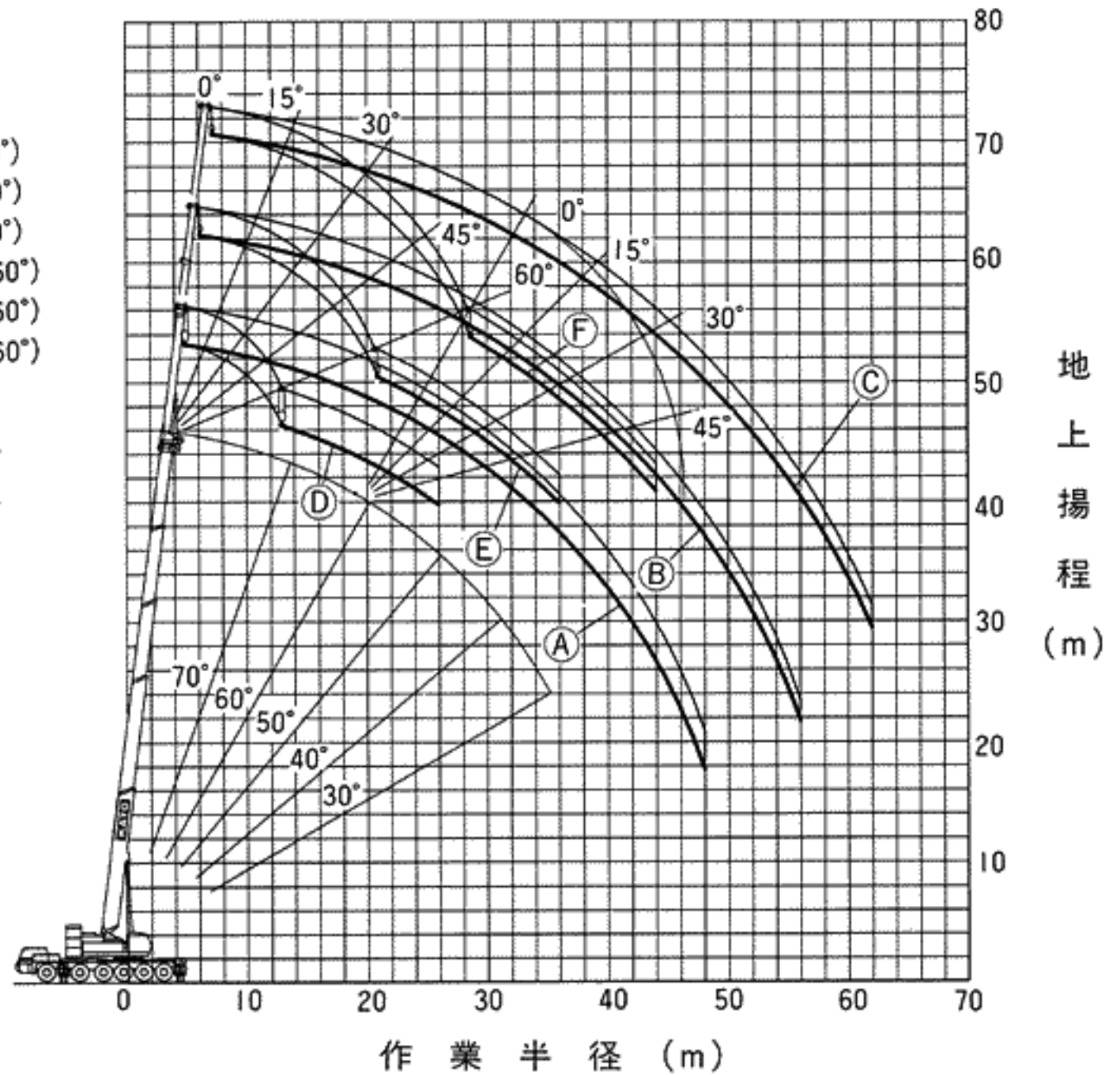
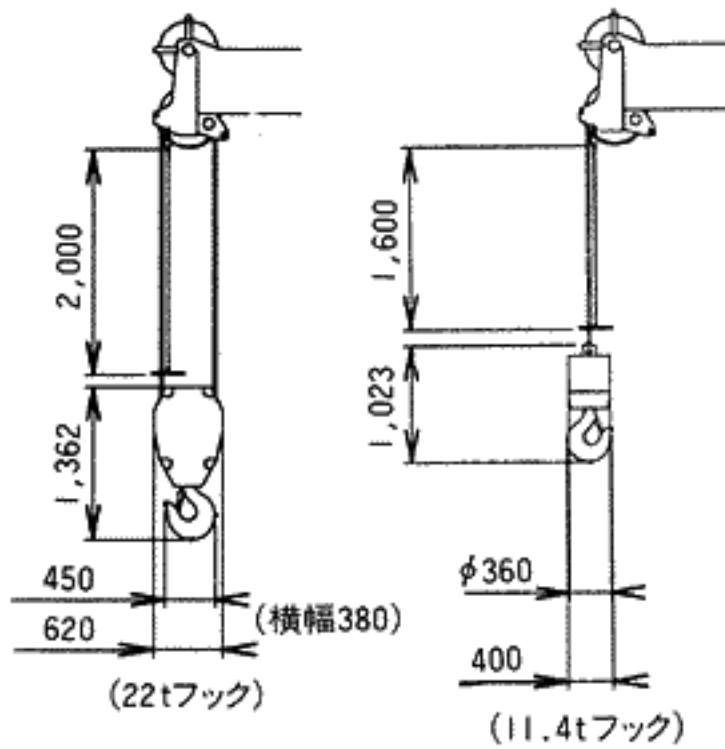

注) 本図は、ブーム及びSLジブのたわみを含んでいません。

50mブーム+10.5m~27.3mSLジブ

- Ⓐ 50.0mブーム+10.5mSLジブ(オフセット0°)
- Ⓑ 50.0mブーム+18.9mSLジブ(オフセット0°)
- Ⓒ 50.0mブーム+27.3mSLジブ(オフセット0°)
- Ⓓ 50.0mブーム+10.5mSLジブ(オフセット60°)
- Ⓔ 50.0mブーム+18.9mSLジブ(オフセット60°)
- Ⓕ 50.0mブーム+27.3mSLジブ(オフセット60°)

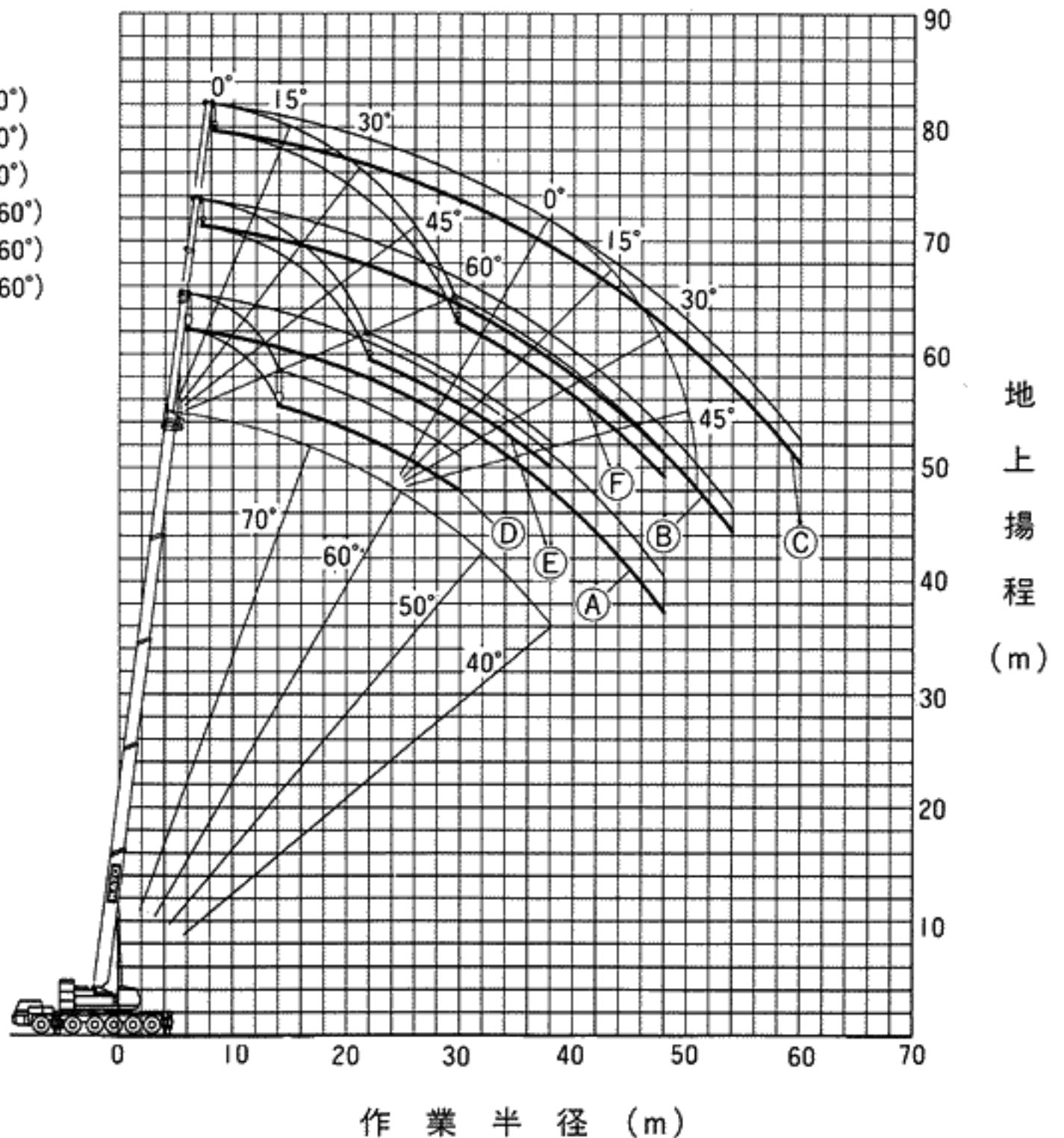

注) 本図は、ブーム及びSLジブのたわみを含んでいません。

スーパーラフティングジブ(SLジブ)

■ 定格総荷重表

■ A性能

40.9m・50mブーム+10.5m~27.3mSLジブ

■40.9mブーム+10.5mSLジブ

A性能

作業半径 (m)	0°		15°		30°		45°		60°	
	角度	荷重	角度	荷重	角度	荷重	角度	荷重	角度	荷重
9.0	81.0	22.0								
10.0	78.9	22.0								
11.0	77.8	22.0								
12.0	76.7	22.0	79.5	21.3						
14.0	74.5	22.0	77.1	19.7	79.5	15.8				
16.0	72.3	22.0	74.9	18.4	77.2	15.0	78.8	12.4		
18.0	70.0	21.7	72.6	17.2	74.8	14.4	76.5	12.0	77.3	9.8
20.0	67.7	19.4	70.3	15.9	72.5	13.8	74.1	11.7	74.8	9.6
22.0	65.4	17.4	67.9	14.6	70.1	12.8	71.5	11.5	72.1	9.6
24.0	63.0	15.6	65.5	13.4	67.6	11.9	68.9	11.0	69.3	9.5
26.0	60.5	14.0	63.0	12.4	65.0	11.2	66.1	10.4	66.3	9.5
28.0	58.0	12.7	60.5	11.5	62.4	10.5	63.2	9.9		
30.0	55.3	11.5	57.9	10.7	59.7	9.8	60.2	9.4		
32.0	52.6	10.5	55.1	9.9	56.8	9.2	57.2	8.9		
34.0	49.8	9.6	52.3	9.1	53.9	8.7	54.1	8.4		
36.0	46.9	8.7	49.3	8.4	50.7	8.1	51.0	8.0		
38.0	43.7	7.7	46.1	7.7	47.4	7.5				
40.0	40.4	6.5	42.6	7.0	43.7	7.0				
42.0	36.7	5.4	38.8	5.8	39.6	6.0				
44.0	32.6	4.3	34.5	4.7	35.0	4.8				
46.0	27.8	3.4	29.5	3.7						
48.0	21.9	2.5	23.1	2.6						
θ(°)	17~83		17~83		30~83		45~83		60~83	
標準フック	22 ton									
フック荷重	880 kg									
フック掛数	2本									

(単位: ton)

■50mブーム+10.5mSLジブ

A性能

作業半径 (m)	0°		15°		30°		45°		60°	
	角度	荷重	角度	荷重	角度	荷重	角度	荷重	角度	荷重
11.0	80.6	17.0								
12.0	79.7	17.0								
14.0	77.9	17.0	80.2	17.0						
16.0	75.9	17.0	78.3	17.0	80.0	15.3				
18.0	74.0	17.0	76.4	17.0	78.0	14.7	79.6	12.3	80.1	9.8
20.0	72.1	16.4	74.4	15.2	76.2	13.4	77.5	12.0	78.1	9.7
22.0	70.2	14.4	72.4	13.5	74.2	12.3	75.4	11.3	76.0	9.6
24.0	68.2	12.6	70.4	12.0	72.2	11.2	73.2	10.4	73.9	9.5
26.0	66.2	11.2	68.3	10.7	70.1	10.3	71.1	9.7	71.7	9.3
28.0	64.1	9.9	66.2	9.5	68.0	9.2	68.9	9.0	69.3	8.7
30.0	62.0	8.9	64.0	8.5	65.8	8.3	66.6	8.2	67.0	8.1
32.0	59.8	7.9	61.9	7.7	63.5	7.5	64.3	7.4		
34.0	57.6	7.0	59.6	6.9	61.2	6.8	62.0	6.7		
36.0	55.3	6.3	57.4	6.2	58.8	6.1	59.5	6.1		
38.0	53.0	5.6	55.0	5.5	56.4	5.5	57.0	5.5		
40.0	50.6	4.9	52.6	5.0	53.8	4.9	54.3	4.9		
42.0	48.1	4.3	50.1	4.4	51.2	4.4	51.5	4.4		
44.0	45.5	3.7	47.5	3.9	48.4	4.0				
46.0	42.7	3.2	44.6	3.3	45.5	3.4				
48.0	39.8	2.3	41.5	2.7	42.3	2.9				
50.0					38.9	2.0				
θ(°)	26~83		26~83		30~83		45~83		60~83	
標準フック	22 ton									
フック荷重	880 kg									
フック掛数	2本									

(単位: ton)

■40.9mブーム+18.9mSLジブ

A性能

作業半径 (m)	0°		15°		30°		45°		60°	
	角度	荷重	角度	荷重	角度	荷重	角度	荷重	角度	荷重
10.0	81.1	10.0								
11.0	80.1	10.0								
12.0	79.2	10.0								
14.0	77.3	10.0								
16.0	75.4	10.0	79.4	10.0						
18.0	73.4	10.0	77.4	10.0						
20.0	71.5	10.0	75.4	10.0	79.2	7.7				
22.0	69.5	10.0	73.4	9.4	77.2	7.4	80.3	6.0		
24.0	67.5	10.0	71.4	8.8	75.1	7.1	78.1	5.8	80.4	4.6
26.0	65.4	10.0	69.3	8.3	73.0	6.8	75.9	5.6	77.7	4.5
28.0	63.3	9.4	67.2	7.8	70.9	6.5	73.5	5.5	75.0	4.4
30.0	61.1	8.7	65.1	7.4	68.6	6.3	71.1	5.3	72.4	4.4
32.0	58.9	8.1	62.9	7.0	66.4	6.0	68.7	5.2	69.7	4.4
34.0	56.7	7.5	60.7	6.7	64.1	5.8	66.2	5.1	67.0	4.3
36.0	54.5	7.0	58.4	6.3	61.7	5.6	63.6	5.0	64.1	4.3
38.0	52.2	6.6	56.0	6.1	59.2	5.4	60.9	4.9		
40.0	49.9	6.2	53.6	5.8	56.6	5.2	57.9	4.8		
42.0	47.4	5.8	51.1	5.4	53.9	5.0	54.8	4.7		
44.0	44.8	5.5	48.4	5.1	50.9	4.8	51.5	4.6		
46.0	42.0	5.2	45.4	4.8	47.8	4.5				
48.0	38.9	4.8	42.4	4.5	44.3	4.3				
50.0	35.5	3.9	38.9	4.2	40.5	4.1				
52.0	31.6	3.1	35.0	3.6	36.0	3.9				
54.0	27.3	2.4	30.4	2.8						
56.0	22.2	1.7	24.5	2.0						
θ(°)	17~83		20~83		30~83		45~83		60~83	
標準フック	11.4 ton									
フック荷重	420 kg									
フック掛数	1本									

(単位: ton)

■50mブーム+18.9mSLジブ

A性能

作業半径 (m)	0°		15°		30°		45°		60°	
	角度	荷重	角度	荷重	角度	荷重	角度	荷重	角度	荷重
12.0	81.5	9.5								
14.0	79.8	9.5								
16.0	78.2	9.5								
18.0	76.6	9.5	80.2	9.5						
20.0	74.9	9.5	78.5	9.5						
22.0	73.2	9.5	76.9	9.5	79.9	7.7				
24.0	71.6	9.5	75.1	9.4	78.1	7.4	80.6	5.9		
26.0	69.8	9.5	73.5	8.8	76.4	7.1	78.8	5.8		
28.0	68.0	9.5	71.8	8.4	74.6	6.9	76.9	5.6	78.1	4.5
30.0	66.3	8.7	70.1	7.9	72.8	6.6	75.0	5.5	76.1	4.4
32.0	64.5	7.8	68.2	7.3	71.0	6.4	73.1	5.4	74.0	4.4
34.0	62.7	7.0	66.3	6.7	69.1	6.1	71.1	5.3	71.9	4.3
36.0	60.8	6.3	64.3	6.1	67.2	5.7	69.1	5.2	69.7	4.3
38.0	58.9	5.7	62.3	5.6	65.3	5.3	67.0	5.0	67.5	4.3
40.0	57.0	5.1	60.3	5.0	63.3	4.9	64.8	4.7		
42.0	55.0	4.6	58.2	4.6	61.3	4.5	62.5	4.4		
44.0	53.0	4.1	56.2	4.1	59.1	4.1	60.2	4.1		
46.0	50.9	3.7	54.1	3.7	56.7	3.7	57.7	3.7		
48.0	48.7	3.3	52.0	3.3	54.2	3.4	55.1	3.4		
50.0	46.4	3.0	49.6	3.0	51.5	3.0	52.3	3.0		
52.0	43.9	2.6	47.2	2.7	48.9	2.7				
54.0	41.3	2.0	44.6	2.4	46.3	2.4				
56.0			41.8	1.9	43.8	2.1				
58.0					40.8	1.5				
θ(°)	26~83		26~83		30~83		45~83		60~83	
標準フック	11.4 ton									
フック荷重	420 kg									
フック掛数	1本									

(単位: ton)

■40.9mブーム+27.3mSLジブ

A性能

作業半径 (m)	0°		15°		30°		45°		60°	
	角度	荷重	角度	荷重	角度	荷重	角度	荷重	角度	荷重
12.0	80.2	6.5								
14.0	78.6	6.5								
16.0	77.0	6.5								
18.0	75.4	6.5								
20.0	73.8	6.5	79.5	6.1						
22.0	72.1	6.5	77.8	5.7						
24.0	70.5	6.5	76.1	5.4						
26.0	68.8	6.5	74.4	5.1	79.2	4.1				
28.0	67.1	6.5	72.6	4.9	77.5	3.9				
30.0	65.3	6.1	70.8	4.7	75.6	3.8	79.3	3.1		
32.0	63.5	5.8	69.0	4.5	73.6	3.6	77.5	3.0		
34.0	61.6	5.4	67.1	4.3	71.6	3.5	75.5	2.9	77.9	2.5
36.0	59.7	5.1	65.1	4.1	69.5	3.3	73.4	2.8	75.4	2.4
38.0	57.8	4.8	63.2	3.9	67.3	3.2	71.2	2.7	72.9	2.4
40.0	55.9	4.4	61.2	3.8	65.1	3.1	68.8	2.7	70.3	2.3
42.0	53.8	4.1	59.1	3.6	62.8	3.0	66.3	2.6	67.6	2.3
44.0	51.8	3.9	57.0	3.5	60.6	2.9	63.7	2.6	64.7	2.3
46.0	49.7	3.6	54.9	3.3	58.2	2.8	60.9	2.5		
48.0	47.6	3.4	52.7	3.1	55.9	2.8	58.1	2.5		
50.0	45.3	3.2	50.4	3.0	53.4	2.7	55.3	2.5		
52.0	43.0	3.0	47.9	2.9	50.8	2.6	52.4	2.5		
54.0	40.5	2.8	45.3	2.7	48.0	2.5				
56.0	37.7	2.6	42.5	2.6	44.9	2.4				
58.0	34.7	2.5	39.3	2.5	41.3	2.4				
60.										

■ B性能

40.9m・50mブーム+10.5m~27.3mSLジブ

■40.9mブーム+10.5m SLジブ B性能

作業半径 (m)	0°		15°		30°		45°		60°	
	角度	荷重	角度	荷重	角度	荷重	角度	荷重	角度	荷重
9.0	81.0	22.0								
10.0	78.9	22.0								
11.0	77.8	22.0								
12.0	76.7	22.0	79.5	21.3						
14.0	74.5	22.0	77.1	19.7	79.5	15.8				
16.0	72.3	22.0	74.9	18.4	77.2	15.0	78.8	12.4		
18.0	70.0	21.7	72.6	17.2	74.8	14.4	76.5	12.0	77.3	9.8
20.0	67.7	19.4	70.3	15.9	72.5	13.8	74.1	11.7	74.8	9.6
22.0	65.4	17.4	67.9	14.6	70.1	12.8	71.5	11.5	72.1	9.6
24.0	63.0	15.6	65.5	13.4	67.6	11.9	68.9	11.0	69.3	9.5
26.0	60.5	14.0	63.0	12.4	65.0	11.2	66.1	10.4	66.3	9.5
28.0	58.0	12.7	60.5	11.5	62.4	10.5	63.2	9.9		
30.0	55.3	11.2	57.9	10.7	59.7	9.8	60.2	9.4		
32.0	52.5	9.4	55.1	9.9	56.8	9.2	57.2	8.9		
34.0	49.6	7.8	52.2	8.6	53.9	8.7	54.1	8.4		
36.0	46.6	6.5	49.1	7.1	50.6	7.6	51.0	7.8		
38.0	43.4	5.1	45.8	5.7	47.1	6.1				
40.0	40.0	3.9	42.2	4.4	43.4	4.7				
42.0	36.3	2.8	38.3	3.2	39.3	3.4				
44.0			34.1	2.1	34.7	2.3				
θ(°)	17~83		17~83		30~83		45~83		60~83	
標準フック	22 ton									
フック荷重	880 kg									
フック掛数	2本									

(単位: ton)

■50mブーム+10.5m SLジブ B性能

作業半径 (m)	0°		15°		30°		45°		60°	
	角度	荷重	角度	荷重	角度	荷重	角度	荷重	角度	荷重
11.0	80.6	17.0								
12.0	79.7	17.0								
14.0	77.9	17.0	80.2	17.0						
16.0	75.9	17.0	78.3	17.0	80.0	15.3				
18.0	74.0	17.0	76.4	17.0	78.0	14.7	79.6	12.3	80.1	9.8
20.0	72.1	16.4	74.4	15.2	76.2	13.4	77.5	12.0	78.1	9.7
22.0	70.2	14.4	72.4	13.5	74.2	12.3	75.4	11.3	76.0	9.6
24.0	68.2	12.6	70.4	12.0	72.2	11.2	73.2	10.4	73.9	9.5
26.0	66.2	11.2	68.3	10.7	70.1	10.3	71.1	9.7	71.7	9.3
28.0	64.1	9.9	66.2	9.5	68.0	9.2	68.9	9.0	69.3	8.7
30.0	62.0	8.9	64.0	8.5	65.8	8.3	66.6	8.2	67.0	8.1
32.0	59.8	7.9	61.9	7.7	63.5	7.5	64.3	7.4		
34.0	57.6	7.0	59.6	6.9	61.2	6.8	62.0	6.7		
36.0	55.3	6.3	57.4	6.2	58.8	6.1	59.5	6.1		
38.0	52.8	4.9	55.0	5.5	56.4	5.5	57.0	5.5		
40.0	50.3	3.7	52.5	4.4	53.8	4.9	54.3	4.9		
42.0	47.7	2.6	49.7	3.2	51.0	3.6	51.3	3.8		
44.0			46.8	2.1	48.1	2.5				
θ(°)	40~83		40~83		40~83		45~83		60~83	
標準フック	22 ton									
フック荷重	880 kg									
フック掛数	2本									

(単位: ton)

■40.9mブーム+18.9m SLジブ B性能

作業半径 (m)	0°		15°		30°		45°		60°	
	角度	荷重	角度	荷重	角度	荷重	角度	荷重	角度	荷重
10.0	81.1	10.0								
11.0	80.1	10.0								
12.0	79.2	10.0								
14.0	77.3	10.0								
16.0	75.4	10.0	79.4	10.0						
18.0	73.4	10.0	77.4	10.0						
20.0	71.5	10.0	75.4	10.0	79.2	7.7				
22.0	69.5	10.0	73.4	9.4	77.2	7.4	80.3	6.0		
24.0	67.5	10.0	71.4	8.8	75.1	7.1	78.1	5.8	80.4	4.6
26.0	65.4	10.0	69.3	8.3	73.0	6.8	75.9	5.6	77.7	4.5
28.0	63.3	9.4	67.2	7.8	70.9	6.5	73.5	5.5	75.0	4.4
30.0	61.1	8.7	65.1	7.4	68.6	6.3	71.1	5.3	72.4	4.4
32.0	58.9	8.1	62.9	7.0	66.4	6.0	68.7	5.2	69.7	4.4
34.0	56.7	7.5	60.7	6.7	64.1	5.8	66.2	5.1	67.0	4.3
36.0	54.5	7.0	58.4	6.3	61.7	5.6	63.6	5.0	64.1	4.3
38.0	52.2	6.6	56.0	6.1	59.2	5.4	60.9	4.9		
40.0	49.9	6.2	53.6	5.8	56.6	5.2	57.9	4.8		
42.0	46.7	5.2	51.1	5.4	53.9	5.0	54.8	4.7		
44.0	44.2	4.1	48.4	5.1	50.9	4.8	51.5	4.6		
46.0	41.1	3.2	45.2	4.0	47.8	4.5				
48.0	37.5	2.4	41.7	3.1	44.1	3.6				
50.0	33.8	1.6	37.7	2.2	39.9	2.6				
52.0			33.3	1.4	35.4	1.7				
θ(°)	30~83		30~83		30~83		45~83		60~83	
標準フック	11.4 ton									
フック荷重	420 kg									
フック掛数	1本									

(単位: ton)

■50mブーム+18.9m SLジブ B性能

作業半径 (m)	0°		15°		30°		45°		60°	
	角度	荷重	角度	荷重	角度	荷重	角度	荷重	角度	荷重
12.0	81.5	9.5								
14.0	79.8	9.5								
16.0	78.2	9.5								
18.0	76.6	9.5	80.2	9.5						
20.0	74.9	9.5	78.5	9.5						
22.0	73.2	9.5	76.9	9.5	79.9	7.7				
24.0	71.6	9.5	75.1	9.4	78.1	7.4	80.6	5.9		
26.0	69.8	9.5	73.5	8.8	76.4	7.1	78.8	5.8		
28.0	68.0	9.5	71.8	8.4	74.6	6.9	76.9	5.6	78.1	4.5
30.0	66.3	8.7	70.1	7.9	72.8	6.6	75.0	5.5	76.1	4.4
32.0	64.5	7.8	68.2	7.3	71.0	6.4	73.1	5.4	74.0	4.4
34.0	62.7	7.0	66.3	6.7	69.1	6.1	71.1	5.3	71.9	4.3
36.0	60.8	6.3	64.3	6.1	67.2	5.7	69.1	5.2	69.7	4.3
38.0	58.9	5.7	62.3	5.6	65.3	5.3	67.0	5.0	67.5	4.3
40.0	57.0	5.1	60.3	5.0	63.3	4.9	64.8	4.7		
42.0	55.0	4.6	58.2	4.6	61.3	4.5	62.5	4.4		
44.0	52.8	3.7	56.2	4.1	59.1	4.1	60.2	4.1		
46.0	50.5	2.8	54.1	3.7	56.7	3.7	57.7	3.7		
48.0	48.1	2.0	51.7	2.9	54.2	3.4	55.1	3.4		
50.0			49.2	2.0	51.4	2.7	52.3	3.0		
52.0			46.6	1.3	48.6	1.8				
θ(°)	41~83		41~83		41~83		45~83		60~83	
標準フック	11.4 ton									
フック荷重	420 kg									
フック掛数	1本									

(単位: ton)

■40.9mブーム+27.3m SLジブ B性能

作業半径 (m)	0°		15°		30°		45°		60°	
	角度	荷重	角度	荷重	角度	荷重	角度	荷重	角度	荷重
12.0	80.2	6.5								
14.0	78.6	6.5								
16.0	77.0	6.5								
18.0	75.4	6.5								
20.0	73.8	6.5	79.5	6.1						
22.0	72.1	6.5	77.8	5.7						
24.0	70.5	6.5	76.1	5.4						
26.0	68.8	6.5	74.4	5.1	79.2	4.1				
28.0	67.1	6.5	72.6	4.9	77.5	3.9				
30.0	65.3	6.1	70.8	4.7	75.6	3.8	79.3	3.1		
32.0	63.5	5.8	69.0	4.5	73.6	3.6	77.5	3.0		
34.0	61.6	5.4	67.1	4.3	71.6	3.5	75.5	2.9	77.9	2.5
36.0	59.7	5.1	65.1	4.1	69.5	3.3	73.4	2.8	75.4	2.4
38.0	57.8	4.8	63.2	3.9	67.3	3.2	71.2	2.7	72.9	2.4
40.0	55.9	4.4	61.2	3.8	65.1	3.1	68.8	2.7	70.3	2.3
42.0	53.8	4.1	59.1	3.6	62.8	3.0	66.3	2.6	67.6	2.3
44.0	51.8	3.9	57.0	3.5	60.6	2.9	63.7	2.6	64.7	2.3
46.0	49.7	3.6	54.9	3.3	58.2	2.8	60.9	2.5		
48.0	47.6	3.4	52.7	3.1	55.9	2.8	58.1	2.5		
50.0	45.3	3.2	50.4	3.0	53.4	2.7	55.3	2.5		
52.0	42.5	2.5	47.9	2.9	50.8	2.6	52.4	2.5		
54.0	39.5	1.9	45.3	2.7	48.0	2.5				
56.0			42.3	2.1	44.9	2.4				
58.0			38.9	1.4	41.0	1.9				
θ(°)	30~83		30~83		30~83		45~83		60~83	
標準フック	11.4 ton									
フック荷重	420 kg									
フック掛数	1本									

(単位: ton)

■50mブーム+27.3m SLジブ B性能

作業半径 (m)	0°		15°		30°		45°		60°	
	角度	荷重	角度	荷重	角度	荷重	角度	荷重	角度	荷重
14.0	82.0	6.0								
16.0	80.5	6.0								
18.0	79.0	6.0								
20.0	77.5	6.0								
22.0	76.1	6.0	79.8	6.0						
24.0	74.5	6.0	78.4	5.7						
26.0	73.0	6.0	77.0	5.4						
28.0	71.4	6.0	75.5	5.2	79.6	4.0				
30.0	69.8	6.0	74.1	5.0	78.2	3.9				
32.0	68.2	6.0	72.5	4.8	76.6	3.8	80.2	3.0		
34.0	66.7	6.0	71.0	4.6	75.1	3.6	78.3			

■ C性能

40.9m・50mブーム+10.5m~27.3mSLジブ

■40.9mブーム+10.5mSLジブ

C性能

作業半径 (m)	0°		15°		30°		45°		60°	
	角度	荷重	角度	荷重	角度	荷重	角度	荷重	角度	荷重
9.0	81.0	22.0								
10.0	78.9	22.0								
11.0	77.8	22.0								
12.0	76.7	22.0	79.5	21.3						
14.0	74.5	22.0	77.1	19.7	79.5	15.8				
16.0	72.3	22.0	74.9	18.4	77.2	15.0	78.8	12.4		
18.0	70.0	21.7	72.6	17.2	74.8	14.4	76.5	12.0	77.3	9.8
20.0	67.7	19.1	70.3	15.9	72.5	13.8	74.1	11.7	74.8	9.6
22.0	65.3	15.7	67.9	14.6	70.1	12.8	71.5	11.5	72.1	9.6
24.0	62.7	12.9	65.5	13.4	67.6	11.9	68.9	11.0	69.3	9.5
26.0	60.2	10.5	63.0	11.6	65.0	11.2	66.1	10.4	63.3	9.5
28.0	57.5	8.4	60.3	9.4	62.3	10.3	63.2	9.9		
30.0	54.8	6.4	57.5	7.5	59.5	8.3	60.2	8.7		
32.0	52.0	4.7	54.6	5.7	56.4	6.4	57.0	6.8		
34.0	49.1	3.3	51.6	4.1	53.2	4.7	53.7	5.0		
36.0	46.0	2.0	48.3	2.7	49.9	3.2	50.4	3.4		
38.0					46.4	1.9				
θ(°)	41~83		42~83		42~83		45~83		60~83	
標準フック	22 ton									
フック荷重	880 kg									
フック掛数	2本									

(単位: ton)

■50mブーム+10.5mSLジブ

C性能

作業半径 (m)	0°		15°		30°		45°		60°	
	角度	荷重	角度	荷重	角度	荷重	角度	荷重	角度	荷重
11.0	80.6	17.0								
12.0	79.7	17.0								
14.0	77.9	17.0	80.2	17.0						
16.0	75.9	17.0	78.3	17.0	80.0	15.3				
18.0	74.0	17.0	76.4	17.0	78.0	14.7	79.6	12.3	80.1	9.8
20.0	72.1	16.4	74.4	15.2	76.2	13.4	77.5	12.0	78.1	9.7
22.0	70.2	14.4	72.4	13.5	74.2	12.3	75.4	11.3	76.0	9.6
24.0	68.2	12.6	70.4	12.0	72.2	11.2	73.2	10.4	73.9	9.5
26.0	66.1	10.4	68.3	10.7	70.1	10.3	71.1	9.7	71.7	9.3
28.0	63.9	8.2	66.2	9.4	68.0	9.2	68.9	9.0	69.3	8.7
30.0	61.6	6.3	63.8	7.4	65.8	8.3	66.6	8.2	67.0	8.1
32.0	59.3	4.6	61.5	5.6	63.4	6.4	64.3	7.0		
34.0	56.9	3.1	58.9	4.0	60.9	4.8	61.7	5.3		
36.0			56.4	2.7	58.5	3.3	59.0	3.7		
38.0							56.3	2.4		
θ(°)	52~83		52~83		52~83		52~83		60~83	
標準フック	22 ton									
フック荷重	880 kg									
フック掛数	2本									

(単位: ton)

■40.9mブーム+18.9mSLジブ

C性能

作業半径 (m)	0°		15°		30°		45°		60°	
	角度	荷重	角度	荷重	角度	荷重	角度	荷重	角度	荷重
10.0	81.1	10.0								
11.0	80.1	10.0								
12.0	79.2	10.0								
14.0	77.3	10.0								
16.0	75.4	10.0	79.4	10.0						
18.0	73.4	10.0	77.4	10.0						
20.0	71.5	10.0	75.4	10.0	79.2	7.7				
22.0	69.5	10.0	73.4	9.4	77.2	7.4	80.3	6.0		
24.0	67.5	10.0	71.4	8.8	75.1	7.1	78.1	5.8	80.4	4.6
26.0	65.4	10.0	69.3	8.3	73.0	6.8	75.9	5.6	77.7	4.5
28.0	63.3	9.4	67.2	7.8	70.9	6.5	73.5	5.5	75.0	4.4
30.0	61.1	8.7	65.1	7.4	68.6	6.3	71.1	5.3	72.4	4.4
32.0	58.8	7.3	62.9	7.0	66.4	6.0	68.7	5.2	69.7	4.4
34.0	56.5	5.8	60.7	6.7	64.1	5.8	66.2	5.1	67.0	4.3
36.0	54.1	4.5	58.3	5.9	61.7	5.6	63.6	5.0	64.1	4.3
38.0	51.5	3.3	55.9	4.6	59.2	5.4	60.9	4.9		
40.0	48.8	2.3	53.2	3.4	56.4	4.4	57.9	4.8		
42.0	45.9	1.4	50.4	2.4	53.5	3.2	54.6	3.7		
44.0					50.3	2.2	51.2	2.5		
θ(°)	43~83		45~83		45~83		45~83		60~83	
標準フック	11.4 ton									
フック荷重	420 kg									
フック掛数	1本									

(単位: ton)

■50mブーム+18.9mSLジブ

C性能

作業半径 (m)	0°		15°		30°		45°		60°	
	角度	荷重	角度	荷重	角度	荷重	角度	荷重	角度	荷重
12.0	81.5	9.5								
14.0	79.8	9.5								
16.0	78.2	9.5								
18.0	76.6	9.5	80.2	9.5						
20.0	74.9	9.5	78.5	9.5						
22.0	73.2	9.5	76.9	9.5	79.9	7.7				
24.0	71.6	9.5	75.1	9.4	78.1	7.4	80.6	5.9		
26.0	69.8	9.5	73.5	8.8	76.4	7.1	78.8	5.8		
28.0	68.0	9.5	71.8	8.4	74.6	6.9	76.9	5.6	78.1	4.5
30.0	66.3	8.5	70.1	7.9	72.8	6.6	75.0	5.5	76.1	4.4
32.0	64.3	6.9	68.2	7.3	71.0	6.4	73.1	5.4	74.0	4.4
34.0	62.3	5.4	66.3	6.7	69.1	6.1	71.1	5.3	71.9	4.3
36.0	60.2	4.1	64.2	5.6	67.2	5.7	69.1	5.2	69.7	4.3
38.0			62.0	4.3	65.3	5.3	67.0	5.0	67.5	4.3
40.0			59.8	3.2	63.1	4.3	64.8	4.7		
42.0					60.8	3.2	62.4	3.8		
44.0					58.3	2.1	59.8	2.7		
θ(°)	54~83		54~83		54~83		55~83		60~83	
標準フック	11.4 ton									
フック荷重	420 kg									
フック掛数	1本									

(単位: ton)

■40.9mブーム+27.3mSLジブ

C性能

作業半径 (m)	0°		15°		30°		45°		60°	
	角度	荷重	角度	荷重	角度	荷重	角度	荷重	角度	荷重
12.0	80.2	6.5								
14.0	78.6	6.5								
16.0	77.0	6.5								
18.0	75.4	6.5								
20.0	73.8	6.5	79.5	6.1						
22.0	72.1	6.5	77.8	5.7						
24.0	70.5	6.5	76.1	5.4						
26.0	68.8	6.5	74.4	5.1	79.2	4.1				
28.0	67.1	6.5	72.6	4.9	77.5	3.9				
30.0	65.3	6.1	70.8	4.7	75.6	3.8	79.3	3.1		
32.0	63.5	5.8	69.0	4.5	73.6	3.6	77.5	3.0		
34.0	61.6	5.4	67.1	4.3	71.6	3.5	75.5	2.9	77.9	2.5
36.0	59.7	5.1	65.1	4.1	69.5	3.3	73.4	2.8	75.4	2.4
38.0	57.8	4.8	63.2	3.9	67.3	3.2	71.2	2.7	72.9	2.4
40.0	55.8	4.0	61.2	3.8	65.1	3.1	68.8	2.7	70.3	2.3
42.0	53.6	3.0	59.1	3.6	62.8	3.0	66.3	2.6	67.6	2.3
44.0	51.3	2.2	57.0	3.5	60.6	2.9	63.7	2.6	64.7	2.3
46.0	48.9	1.4	54.7	2.7	58.2	2.8	60.9	2.5		
48.0			52.2	1.9	55.9	2.8	58.1	2.5		
50.0					53.3	2.1	55.3	2.5		
52.0							52.2	1.8		
θ(°)	44~83		47~83		48~83		48~83		60~83	
標準フック	11.4 ton									
フック荷重	420 kg									
フック掛数	1本									

(単位: ton)

■50mブーム+27.3mSLジブ

C性能

作業半径 (m)	0°		15°		30°		45°		60°	
	角度	荷重	角度	荷重	角度	荷重	角度	荷重	角度	荷重
14.0	82.0	6.0								
16.0	80.5	6.0								
18.0	79.0	6.0								
20.0	77.5	6.0								
22.0	76.1	6.0	79.8	6.0						
24.0	74.5	6.0	78.4	5.7						
26.0	73.0	6.0	77.0	5.4						
28.0	71.4	6.0	75.5	5.2	79.6	4.0				
30.0	69.8	6.0	74.1	5.0	78.2	3.9				
32.0	68.2	6.0	72.5	4.8	76.6	3.8	80.2	3.0		
34.0	66.7	6.0	71.0	4.6	75.1	3.6	78.3	3.0	80.3	2.5
36.0	65.0	5.6	69.4	4.4	73.4	3.5	76.5	2.9	78.3	2.4
38.0	63.1	4.4	67.8	4.2	71.7	3.4	74.6	2.8	76.3	2.4
40.0	61.2	3.4	66.1	4.1	70.0	3.3	72.8	2.8	74.3	2.4
42.0	59.2	2.4	64.5	3.9	68.2	3.2	70.9	2.7	72.2	2.3
44.0			62.5	3.2	66.4	3.1	68.9	2.7	70.0	2.3
46.0			60.3	2.3	64.5	3.0	66.9	2.6	67.7	2.3
48.0					62.6	2.8	64.8	2.6	65.3	2.3
50.0					60.3	1.9	62.7	2.5		
52.0							60.1	1.9		
θ(°)	54~83		55~83		55~83		55~83		60~83	
標準フック	11.4 ton									
フック荷重	420 kg									
フック掛数	1本									

(単位: ton)

■ D性能

40.9m・50mブーム+10.5m~27.3mSLジブ

■40.9mブーム+10.5m SLジブ

D性能

作業半径 (m)	0°		15°		30°		45°		60°	
	角度	荷重	角度	荷重	角度	荷重	角度	荷重	角度	荷重
9.0	81.0	22.0								
10.0	78.9	22.0								
11.0	77.8	22.0								
12.0	76.7	22.0	79.5	21.3						
14.0	74.5	22.0	77.1	19.7	79.5	15.8				
16.0	72.3	22.0	74.9	18.4	77.2	15.0	78.8	12.4		
18.0	69.8	19.0	72.6	17.2	74.8	14.4	76.5	12.0	77.3	9.8
20.0	67.4	14.9	70.3	15.9	72.5	13.8	74.1	11.7	74.8	9.6
22.0	64.9	11.7	67.8	13.1	70.1	12.8	71.5	11.5	72.1	9.6
24.0	62.2	8.9	65.2	10.3	67.5	11.4	68.9	11.0	69.3	9.5
26.0	59.7	6.4	62.6	7.9	64.7	8.9	66.0	9.6	66.3	9.5
28.0	57.1	4.4	59.8	5.6	61.9	6.6	63.0	7.3		
30.0	54.3	2.6	57.0	3.7	58.9	4.6	59.9	5.2		
32.0					55.9	2.9	56.7	3.3		
θ(°)	51~83		52~83		52~83		53~83		60~83	
標準フック	22 ton									
フック荷重	880 kg									
フック掛数	2本									

(単位: ton)

■50mブーム+10.5m SLジブ

D性能

作業半径 (m)	0°		15°		30°		45°		60°	
	角度	荷重	角度	荷重	角度	荷重	角度	荷重	角度	荷重
11.0	80.6	17.0								
12.0	79.7	17.0								
14.0	77.9	17.0	80.2	17.0						
16.0	75.9	17.0	78.3	17.0	80.0	15.3				
18.0	74.0	17.0	76.4	17.0	78.0	14.7	79.6	12.3	80.1	9.8
20.0	71.9	14.4	74.4	15.2	76.2	13.4	77.5	12.0	78.1	9.7
22.0	69.8	11.2	72.3	12.9	74.2	12.3	75.4	11.3	76.0	9.6
24.0	67.7	8.7	70.1	10.2	72.2	11.2	73.2	10.4	73.9	9.5
26.0			67.9	7.8	70.0	8.9	71.1	9.7	71.7	9.3
28.0					67.6	6.7	68.6	7.5	69.2	7.8
30.0									66.6	5.7
θ(°)	63~83		63~83		63~83		63~83		63~83	
標準フック	22 ton									
フック荷重	880 kg									
フック掛数	2本									

(単位: ton)

■40.9mブーム+18.9m SLジブ

D性能

作業半径 (m)	0°		15°		30°		45°		60°	
	角度	荷重	角度	荷重	角度	荷重	角度	荷重	角度	荷重
10.0	81.1	10.0								
11.0	80.1	10.0								
12.0	79.2	10.0								
14.0	77.3	10.0								
16.0	75.4	10.0	79.4	10.0						
18.0	73.4	10.0	77.4	10.0						
20.0	71.5	10.0	75.4	10.0	79.2	7.7				
22.0	69.5	10.0	73.4	9.4	77.2	7.4	80.3	6.0		
24.0	67.5	10.0	71.4	8.8	75.1	7.1	78.1	5.8	80.4	4.6
26.0	65.3	9.1	69.3	8.3	73.0	6.8	75.9	5.6	77.7	4.5
28.0	63.1	7.1	67.2	7.8	70.9	6.5	73.5	5.5	75.0	4.4
30.0	60.8	5.4	65.1	7.3	68.6	6.3	71.1	5.3	72.4	4.4
32.0	58.5	3.8	62.8	5.6	66.4	6.0	68.7	5.2	69.7	4.4
34.0	56.2	2.5	60.5	4.1	64.0	5.5	66.2	5.1	67.0	4.3
36.0			58.2	2.8	61.5	4.1	63.6	5.0	64.1	4.3
38.0					59.0	2.8	60.5	3.5		
40.0							57.4	2.2		
θ(°)	52~83		54~83		54~83		54~83		60~83	
標準フック	11.4 ton									
フック荷重	420 kg									
フック掛数	1本									

(単位: ton)

■50mブーム+18.9m SLジブ

D性能

作業半径 (m)	0°		15°		30°		45°		60°	
	角度	荷重	角度	荷重	角度	荷重	角度	荷重	角度	荷重
12.0	81.5	9.5								
14.0	79.8	9.5								
16.0	78.2	9.5								
18.0	76.6	9.5	80.2	9.5						
20.0	74.9	9.5	78.5	9.5						
22.0	73.2	9.5	76.9	9.5	79.9	7.7				
24.0	71.6	9.5	75.1	9.4	78.1	7.4	80.6	5.9		
26.0	69.6	8.6	73.5	8.8	76.4	7.1	78.8	5.8		
28.0	67.5	6.7	71.8	8.4	74.6	6.9	76.9	5.6	78.1	4.5
30.0			69.9	7.0	72.8	6.6	75.0	5.5	76.1	4.4
32.0			67.7	5.3	71.0	6.4	73.1	5.4	74.0	4.4
34.0					69.0	5.4	71.1	5.3	71.9	4.3
36.0							69.0	5.0	69.7	4.3
θ(°)	63~83		63~83		63~83		64~83		64~83	
標準フック	11.4 ton									
フック荷重	420 kg									
フック掛数	1本									

(単位: ton)

■40.9mブーム+27.3m SLジブ

D性能

作業半径 (m)	0°		15°		30°		45°		60°	
	角度	荷重	角度	荷重	角度	荷重	角度	荷重	角度	荷重
12.0	80.2	6.5								
14.0	78.6	6.5								
16.0	77.0	6.5								
18.0	75.4	6.5								
20.0	73.8	6.5	79.5	6.1						
22.0	72.1	6.5	77.8	5.7						
24.0	70.5	6.5	76.1	5.4						
26.0	68.8	6.5	74.4	5.1	79.2	4.1				
28.0	67.1	6.5	72.6	4.9	77.5	3.9				
30.0	65.3	6.1	70.8	4.7	75.6	3.8	79.3	3.1		
32.0	63.4	5.6	69.0	4.5	73.6	3.6	77.5	3.0		
34.0	61.4	4.3	67.1	4.3	71.6	3.5	75.5	2.9	77.9	2.5
36.0	59.3	3.1	65.1	4.1	69.5	3.3	73.4	2.8	75.4	2.4
38.0			63.2	3.9	67.3	3.2	71.2	2.7	72.9	2.4
40.0			60.9	2.9	65.1	3.1	68.8	2.7	70.3	2.3
42.0			58.6	2.0	62.8	3.0	66.3	2.6	67.6	2.3
44.0					60.5	2.4	63.7	2.6	64.7	2.3
46.0					58.1	1.5	60.8	2.4		
48.0							58.0	1.4		
θ(°)	54~83		54~83		54~83		55~83		60~83	
標準フック	11.4 ton									
フック荷重	420 kg									
フック掛数	1本									

(単位: ton)

■50mブーム+27.3m SLジブ

D性能

作業半径 (m)	0°		15°		30°		45°		60°	
	角度	荷重	角度	荷重	角度	荷重	角度	荷重	角度	荷重
14.0	82.0	6.0								
16.0	80.5	6.0								
18.0	79.0	6.0								
20.0	77.5	6.0								
22.0	76.1	6.0	79.8	6.0						
24.0	74.5	6.0	78.4	5.7						
26.0	73.0	6.0	77.0	5.4						
28.0	71.4	6.0	75.5	5.2	79.6	4.0				
30.0	69.8	6.0	74.1	5.0	78.2	3.9				
32.0			72.5	4.8	76.6	3.8	80.2	3.0		
34.0			71.0	4.6	75.1	3.6	78.3	3.0	80.3	2.5
36.0			69.4	4.4	73.4	3.5	76.5	2.9	78.3	2.4
38.0					71.7	3.4	74.6	2.8	76.3	2.4
40.0					70.0	3.3	72.8	2.8	74.3	2.4
42.0							70.9	2.7	72.2	2.3
44.0							68.9	2.7	70.0	2.3
46.0									67.7	2.3
θ(°)	64~83		64~83		64~83		64~83		64~83	
標準フック	11.4 ton									
フック荷重	420 kg									
フック掛数	1本									

(単位: ton)

ヘビーリフトジブ

■作業半径揚程図

13.6m~50mブーム+12m・21m・30m・40m・47m・54mヘビーリフトジブ

- | | |
|----------------------------------|----------------------------------|
| Ⓐ 13.6mブーム+12mヘビーリフトジブ(オフセット10°) | Ⓔ 50.0mブーム+21mヘビーリフトジブ(オフセット10°) |
| Ⓑ 13.6mブーム+21mヘビーリフトジブ(オフセット10°) | Ⓕ 50.0mブーム+30mヘビーリフトジブ(オフセット10°) |
| Ⓒ 13.6mブーム+30mヘビーリフトジブ(オフセット10°) | Ⓖ 50.0mブーム+40mヘビーリフトジブ(オフセット10°) |
| Ⓓ 13.6mブーム+12mヘビーリフトジブ(オフセット60°) | Ⓗ 50.0mブーム+47mヘビーリフトジブ(オフセット10°) |
| Ⓔ 13.6mブーム+21mヘビーリフトジブ(オフセット60°) | Ⓚ 50.0mブーム+54mヘビーリフトジブ(オフセット10°) |
| Ⓕ 13.6mブーム+30mヘビーリフトジブ(オフセット60°) | Ⓛ 50.0mブーム+21mヘビーリフトジブ(オフセット60°) |
| | Ⓜ 50.0mブーム+30mヘビーリフトジブ(オフセット60°) |
| | Ⓝ 50.0mブーム+40mヘビーリフトジブ(オフセット60°) |
| | Ⓞ 50.0mブーム+47mヘビーリフトジブ(オフセット60°) |
| | Ⓟ 50.0mブーム+54mヘビーリフトジブ(オフセット45°) |

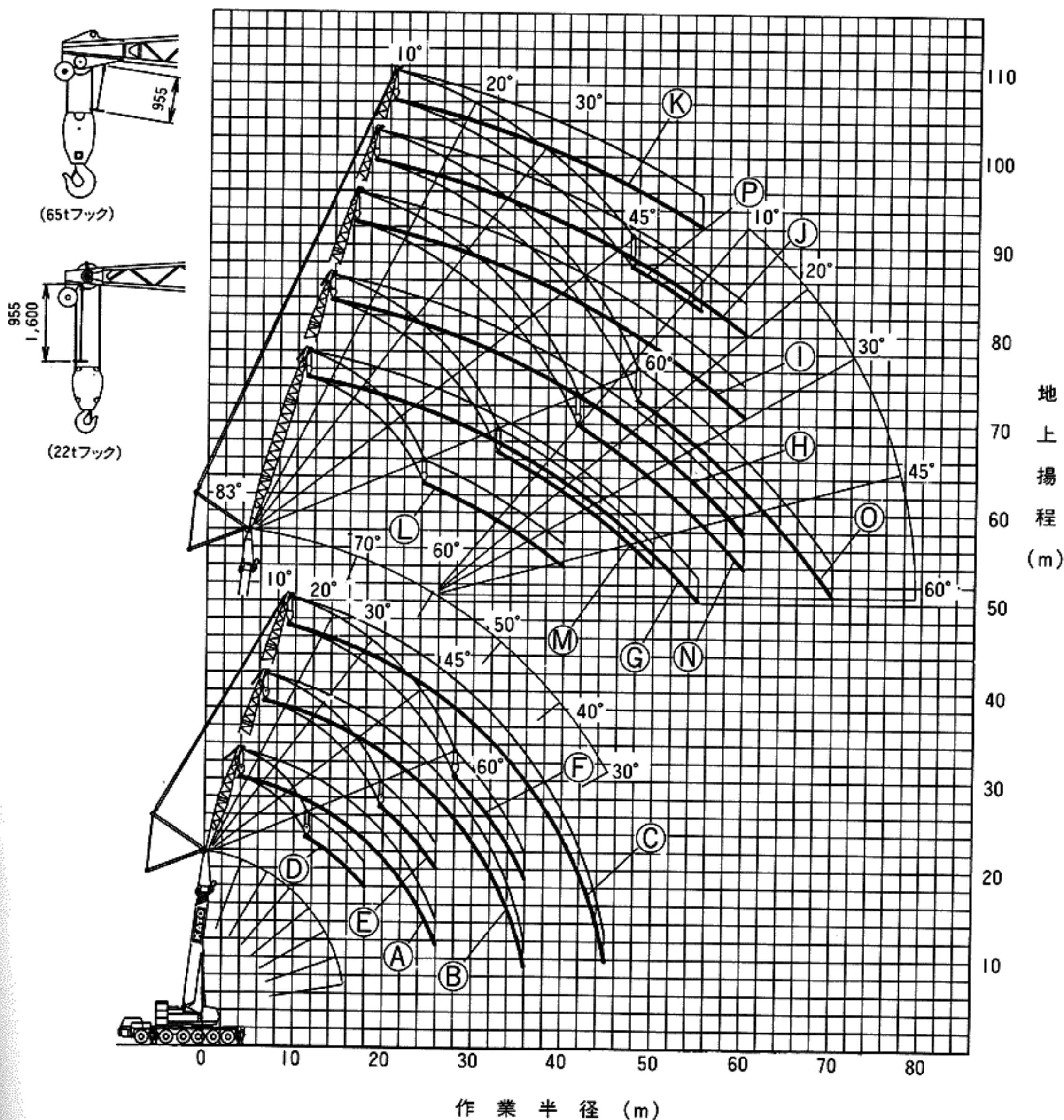

注) 本図は、ブーム及びヘビーリフトジブのたわみを含んでいません。

ヘビーリフトジブ(12m・54m)

■定格総荷重表

■ A性能

13.6m~50mブーム+4.35m

■13.6mブーム+4.35m+12mヘビーリフトジブ

A性能

作業半径	10°	20°	30°	45°	60°
6.0 (m)	84.0				
7.0	83.9				
8.0	82.6	79.3			
9.0	81.4	75.3			
10.0	76.6	71.4	60.9		
11.0	71.0	67.5	58.2		
12.0	65.2	64.1	55.8	43.2	
14.0	55.8	58.2	51.6	40.9	31.9
16.0	48.6	50.9	48.2	39.1	31.2
18.0	42.8	43.9	44.6	37.7	30.9
20.0	37.7	38.3	38.8	36.7	
22.0	33.2	33.7	34.0	34.3	
24.0	29.5	29.8	30.0		
26.0	26.3	26.5			
θ(°)	10~83	20~83	30~83	45~83	60~83
標準フック	150 ton				
フック重量	1850 kg				
巻掛本数	8本				

(単位: ton)

■31.8mブーム+4.35m+12mヘビーリフトジブ

A性能

作業半径	10°	20°	30°	45°	60°
9.0 (m)	40.0				
10.0	39.5				
11.0	38.8	34.9			
12.0	38.2	34.4			
14.0	37.0	33.6	30.6		
16.0	36.0	32.8	30.0	26.2	
18.0	33.3	32.2	29.6	26.0	22.6
20.0	29.9	30.9	29.2	25.8	22.6
22.0	26.6	27.5	28.5	25.7	22.6
24.0	23.7	24.5	25.3	25.7	22.6
26.0	21.3	22.0	22.7	23.6	22.6
28.0	19.2	19.8	20.4	21.1	
30.0	17.3	17.8	18.3	18.9	
32.0	15.2	15.7	16.1	16.5	
34.0	13.4	13.9	14.2	14.4	
36.0	11.8	12.2	12.4		
38.0	10.4	10.6	10.8		
40.0	9.1	9.3	9.4		
45.0	4.6				
θ(°)	10~83	20~83	30~83	45~83	60~83
標準フック	65 ton				
フック重量	1000 kg				
巻掛本数	4本				

(単位: ton)

■18.15mブーム+4.35m+12mヘビーリフトジブ

A性能

作業半径	10°	20°	30°	45°	60°
7.0 (m)	77.0				
8.0	77.0				
9.0	77.0	77.0			
10.0	75.5	75.3			
11.0	69.7	70.1	60.7		
12.0	64.4	65.1	58.4		
14.0	55.3	56.7	54.4	43.5	34.0
16.0	47.8	49.0	50.1	41.7	33.2
18.0	40.9	41.9	42.9	40.1	32.5
20.0	35.5	36.3	37.0	37.9	32.4
22.0	31.0	31.6	32.3	32.9	
24.0	27.2	27.8	28.3	28.7	
26.0	24.1	24.5	24.9		
28.0	21.4	21.7	21.9		
30.0	19.0	19.2			
32.0	12.4				
θ(°)	10~83	20~83	30~83	45~83	60~83
標準フック	150 ton				
フック重量	1850 kg				
巻掛本数	8本				

(単位: ton)

■40.9mブーム+4.35m+54mヘビーリフトジブ

A性能

作業半径	10°	20°	30°	45°	60°
26.0 (m)	3.8				
28.0	3.8				
30.0	3.8				
32.0	3.8				
34.0	3.8	3.7			
36.0	3.8	3.5			
38.0	3.8	3.3			
40.0	3.8	3.2			
45.0	3.4	2.8	2.4		
50.0	3.0	2.5	2.2		
55.0	2.7	2.3	2.0	1.7	
60.0	2.4	2.1	1.9	1.6	1.5
65.0	2.2	1.9	1.7	1.5	1.5
70.0	2.0	1.8	1.6	1.5	1.5
75.0		1.7	1.6	1.5	
80.0			1.5	1.5	
θ(°)	40~83	40~83	40~83	45~83	60~83
標準フック	22 ton				
フック重量	880 kg				
巻掛本数	2本				

(単位: ton)

■22.7mブーム+4.35m+12mヘビーリフトジブ

A性能

作業半径	10°	20°	30°	45°	60°
8.0 (m)	64.0				
9.0	64.0				
10.0	64.0	64.0			
11.0	64.0	64.0	64.0		
12.0	60.3	61.6	61.8		
14.0	51.8	53.3	54.4	46.9	
16.0	44.8	46.3	47.7	45.0	35.5
18.0	39.2	40.4	41.5	42.9	34.8
20.0	33.7	34.7	35.7	36.8	34.4
22.0	29.2	30.1	30.9	31.8	32.2
24.0	25.5	26.2	26.9	27.6	
26.0	22.3	23.0	23.5	24.0	
28.0	19.6	20.2	20.6	20.9	
30.0	17.3	17.7	18.0		
32.0	15.3	15.6	15.8		
34.0	13.5	13.7			
36.0	9.6				
θ(°)	10~83	20~83	30~83	45~83	60~83
標準フック	65 ton				
フック重量	1000 kg				
巻掛本数	6本				

(単位: ton)

■50mブーム+4.35m+54mヘビーリフトジブ

A性能

作業半径	10°	20°	30°	45°
28.0 (m)	2.5			
30.0	2.5			
32.0	2.5			
34.0	2.5			
36.0	2.5	2.5		
38.0	2.5	2.5		
40.0	2.5	2.5		
45.0	2.5	2.5	2.4	
50.0	2.5	2.5	2.2	
55.0	2.2	2.2	2.0	1.5
60.0		2.1	1.9	
65.0			1.8	
θ(°)	51~83	52~83	52~83	55~83
標準フック	22 ton			
フック重量	880 kg			
巻掛本数	2本			

(単位: ton)

ヘビーリフトジブ(21m)

■ A 性能

13.6m~50mブーム+4.35m

作業半径	10°	20°	30°	45°	60°
9.0 (m)	55.5				
10.0	54.7				
11.0	53.6				
12.0	52.6				
14.0	48.7	41.4			
16.0	43.5	37.7	33.0		
18.0	39.4	34.6	30.7		
20.0	35.9	32.0	28.7	22.9	
22.0	33.0	29.9	27.0	21.9	17.2
24.0	30.6	28.0	25.6	21.0	16.8
26.0	28.1	26.4	24.3	20.3	16.5
28.0	25.1	25.0	23.2	19.7	
30.0	22.6	23.0	22.4	19.4	
32.0	20.4	20.7	21.0		
34.0	18.6	18.8	18.9		
36.0	15.9				
θ(°)	10~83	20~83	30~83	45~83	60~83
標準フック	65 ton				
フック重量	1000 kg				
巻掛本数	6本				

(単位: ton)

作業半径	10°	20°	30°	45°	60°
14.0 (m)	27.0				
16.0	27.0	25.0			
18.0	27.0	24.1			
20.0	26.0	23.4	21.1		
22.0	25.1	22.8	20.6		
24.0	24.3	22.2	20.1	17.2	
26.0	22.7	21.7	19.7	17.0	14.3
28.0	20.9	21.2	19.4	16.8	14.2
30.0	18.9	19.9	19.1	16.6	14.2
32.0	17.0	17.9	18.7	16.6	14.2
34.0	15.2	15.9	16.6	16.5	14.2
36.0	13.5	14.2	14.8	15.5	14.2
38.0	12.1	12.7	13.2	13.8	
40.0	10.7	11.4	11.8	12.3	
45.0	7.9	8.4	8.7		
50.0	5.7	6.0			
θ(°)	11~83	20~83	30~83	45~83	60~83
標準フック	65 ton				
フック重量	1000 kg				
巻掛本数	4本				

(単位: ton)

作業半径	10°	20°	30°	45°	60°
10.0 (m)	53.0				
11.0	53.0				
12.0	53.0				
14.0	51.8	43.3			
16.0	47.2	39.7	34.3		
18.0	42.8	36.6	32.0		
20.0	37.9	34.0	30.2	24.2	
22.0	33.4	31.8	28.5	23.2	18.1
24.0	29.6	29.9	27.1	22.3	17.7
26.0	26.3	27.3	25.8	21.6	17.4
28.0	23.5	24.2	24.7	21.0	17.2
30.0	20.9	21.6	22.1	20.5	
32.0	18.8	19.3	19.8	20.1	
34.0	16.9	17.4	17.7	18.1	
36.0	15.3	15.6	15.9		
38.0	13.9	14.1	14.3		
40.0	12.1	12.7			
θ(°)	10~83	20~83	30~83	45~83	60~83
標準フック	65 ton				
フック重量	1000 kg				
巻掛本数	6本				

(単位: ton)

作業半径	10°	20°	30°	45°	60°
16.0 (m)	16.0				
18.0	16.0	16.0			
20.0	16.0	16.0			
22.0	16.0	16.0	16.0		
24.0	16.0	16.0	16.0		
26.0	16.0	16.0	16.0	16.0	
28.0	16.0	16.0	16.0	16.0	14.7
30.0	15.0	15.8	16.0	16.0	14.6
32.0	13.7	14.5	15.2	16.0	14.6
34.0	12.6	13.3	13.9	14.8	14.6
36.0	11.6	12.2	12.8	13.5	14.1
38.0	10.6	11.2	11.7	12.4	12.8
40.0	9.8	10.3	10.8	11.3	
45.0	7.7	8.1	8.5	8.9	
50.0	5.4	5.9	6.2		
55.0	3.5	3.8	4.0		
60.0		1.9			
θ(°)	21~83	22~83	30~83	45~83	60~83
標準フック	22 ton				
フック重量	880 kg				
巻掛本数	2本				

(単位: ton)

作業半径	10°	20°	30°	45°	60°
11.0 (m)	44.0				
12.0	44.0				
14.0	44.0				
16.0	44.0	43.9			
18.0	42.3	40.6	34.7		
20.0	36.7	37.7	32.7		
22.0	32.1	33.7	31.0	25.2	
24.0	28.3	29.6	29.4	24.3	19.1
26.0	25.0	26.2	27.3	23.5	18.7
28.0	22.2	23.2	24.1	22.8	18.5
30.0	19.8	20.6	21.3	22.2	18.3
32.0	17.6	18.3	19.0	19.7	18.2
34.0	15.8	16.4	16.9	17.5	
36.0	14.1	14.6	15.1	15.5	
38.0	12.7	13.1	13.4		
40.0	11.4	11.7	12.0		
45.0	7.0				
θ(°)	10~83	20~83	30~83	45~83	60~83
標準フック	65 ton				
フック重量	1000 kg				
巻掛本数	4本				

(単位: ton)

作業半径	10°	20°	30°	45°	60°
16.0 (m)	9.5				
18.0	9.5				
20.0	9.5	9.5			
22.0	9.5	9.5			
24.0	9.5	9.5	9.5		
26.0	9.5	9.5	9.5	9.1	
28.0	9.5	9.5	9.5	9.0	
30.0	9.5	9.5	9.5	8.9	7.4
32.0	9.5	9.5	9.5	8.8	7.4
34.0	9.2	9.5	9.5	8.8	7.4
36.0	8.4	9.0	9.5	8.8	7.4
38.0	7.6	8.2	8.7	8.8	7.4
40.0	6.9	7.4	7.9	8.5	7.4
45.0	5.2	5.6	6.0	6.5	
50.0	3.8	4.2	4.5	4.9	
55.0	2.7	3.0	3.2	3.4	
60.0			2.0		
θ(°)	38~83	38~83	38~83	45~83	60~83
標準フック	22 ton				
フック重量	880 kg				
巻掛本数	2本				

(単位: ton)

ヘビーリフトジブ(30m)

■ A性能

13.6m~50mブーム+4.35m

作業半径	10°	20°	30°	45°	60°
14.0 (m)	33.0				
16.0	32.4				
18.0	31.8	29.5			
20.0	30.9	27.1			
22.0	28.2	25.1	22.2		
24.0	26.0	23.3	20.8		
26.0	24.1	21.8	19.6		
28.0	22.4	20.5	18.5	15.0	
30.0	21.0	19.3	17.6	14.3	11.2
32.0	19.7	18.3	16.8	13.8	10.9
34.0	18.6	17.4	16.0	13.3	10.6
36.0	17.6	16.6	15.4	13.0	10.5
38.0	16.4	15.9	14.8	12.7	
40.0	15.1	15.2	14.4	12.5	
45.0	12.4				
θ(°)	10~83	20~83	30~83	45~83	60~83
標準フック	65 ton				
フック重量	1000 kg				
巻掛本数	4本				

(単位: ton)

作業半径	10°	20°	30°	45°	60°
16.0 (m)	19.0				
18.0	18.6				
20.0	18.4				
22.0	18.2	18.2			
24.0	18.0	18.0			
26.0	17.8	17.6	15.8		
28.0	17.6	17.1	15.4		
30.0	17.5	16.6	15.1	12.7	
32.0	17.4	16.2	14.7	12.5	
34.0	16.4	15.8	14.4	12.3	10.1
36.0	14.9	15.5	14.2	12.1	10.1
38.0	13.4	14.3	14.0	12.0	10.0
40.0	12.1	12.9	13.7	11.9	10.0
45.0	9.3	10.0	10.6	11.3	10.0
50.0	7.0	7.6	8.2	8.6	
55.0	5.1	5.5	5.9		
60.0	3.4	3.7			
θ(°)	14~83	20~83	30~83	45~83	60~83
標準フック	22 ton				
フック重量	880 kg				
巻掛本数	2本				

(単位: ton)

作業半径	10°	20°	30°	45°	60°
14.0 (m)	32.0				
16.0	32.0				
18.0	32.0	30.6			
20.0	32.0	28.3			
22.0	30.3	26.3	23.1		
24.0	28.0	24.5	21.8		
26.0	26.0	23.0	20.6		
28.0	24.2	21.6	19.6	15.8	
30.0	22.3	20.5	18.7	15.2	
32.0	20.1	19.4	17.8	14.7	11.5
34.0	18.2	18.5	17.1	14.2	11.3
36.0	16.5	17.2	16.4	13.8	11.1
38.0	15.0	15.6	15.8	13.5	11.0
40.0	13.7	14.2	14.7	13.2	
45.0	11.0	11.3	11.6		
50.0	6.3				
θ(°)	10~83	20~83	30~83	45~83	60~83
標準フック	65 ton				
フック重量	1000 kg				
巻掛本数	4本				

(単位: ton)

作業半径	10°	20°	30°	45°	60°
18.0 (m)	11.5				
20.0	11.5				
22.0	11.5				
24.0	11.0	11.0			
26.0	11.0	11.0			
28.0	11.0	11.0	11.0		
30.0	11.0	11.0	11.0		
32.0	11.0	11.0	11.0	11.0	
34.0	11.0	11.0	11.0	11.0	
36.0	11.0	11.0	11.0	11.0	10.2
38.0	10.5	10.8	11.0	11.0	10.2
40.0	9.6	10.4	10.8	11.0	10.1
45.0	7.8	8.4	9.0	9.9	10.1
50.0	6.3	6.8	7.3	8.0	
55.0	4.5	5.1	5.6	6.2	
60.0	2.8	3.3	3.7		
65.0			1.9		
θ(°)	23~83	23~83	30~83	45~83	60~83
標準フック	22 ton				
フック重量	880 kg				
巻掛本数	2本				

(単位: ton)

作業半径	10°	20°	30°	45°	60°
14.0 (m)	30.0				
16.0	30.0				
18.0	30.0				
20.0	30.0	29.3			
22.0	30.0	27.3			
24.0	29.6	25.6	22.4		
26.0	26.5	24.0	21.2		
28.0	23.7	22.7	20.2	16.4	
30.0	21.1	21.5	19.3	15.8	
32.0	18.9	19.9	18.5	15.3	12.0
34.0	17.0	17.9	17.7	14.8	11.7
36.0	15.3	16.2	17.0	14.4	11.5
38.0	13.9	14.6	15.3	14.0	11.4
40.0	12.6	13.2	13.9	13.7	11.3
45.0	9.9	10.3	10.8	11.2	
50.0	7.6	8.0	8.2		
θ(°)	10~83	20~83	30~83	45~83	60~83
標準フック	65 ton				
フック重量	1000 kg				
巻掛本数	4本				

(単位: ton)

作業半径	10°	20°	30°	45°	60°
20.0 (m)	6.6				
22.0	6.6				
24.0	6.6	6.6			
26.0	6.6	6.6			
28.0	6.6	6.6	6.6		
30.0	6.6	6.6	6.6		
32.0	6.6	6.6	6.6		
34.0	6.6	6.6	6.6	5.8	
36.0	6.6	6.6	6.6	5.8	
38.0	6.3	6.5	6.6	5.7	4.5
40.0	6.0	6.3	6.5	5.6	4.5
45.0	5.1	5.7	6.0	5.6	4.5
50.0	3.9	4.4	4.9	5.6	4.5
55.0	2.8	3.3	3.7	4.2	
60.0	1.9	2.3	2.7	3.1	
θ(°)	40~83	40~83	40~83	45~83	64~83
標準フック	22 ton				
フック重量	880 kg				
巻掛本数	2本				

(単位: ton)

ヘビーリフトジブ(40m・47m)

■ A性能

31.8m～50mブーム+4.35m

作業半径	10°	20°	30°	45°	60°
20.0 (m)	11.0				
22.0	11.0				
24.0	11.0				
26.0	11.0	11.0			
28.0	11.0	11.0			
30.0	11.0	11.0			
32.0	11.0	11.0	10.7		
34.0	11.0	11.0	10.2		
36.0	11.0	11.0	9.7		
38.0	11.0	10.7	9.3	7.8	
40.0	11.0	10.2	8.9	7.5	
45.0	10.4	9.1	8.0	7.0	6.2
50.0	8.3	8.2	7.4	6.5	6.0
55.0	6.4	7.2	6.8	6.2	5.9
60.0	4.8	5.5	6.0	6.0	
65.0	3.4	3.9	4.3		
70.0	2.2	2.4			
$\theta(^{\circ})$	15~83	20~83	30~83	45~83	60~83
標準フック	22 ton				
フック重量	880 kg				
巻掛本数	2本				

(単位: ton)

作業半径	10°	20°	30°	45°	60°
22.0 (m)	7.5				
24.0	7.5				
26.0	7.5				
28.0	7.5				
30.0	7.5	7.3			
32.0	7.5	7.0			
34.0	7.5	6.7			
36.0	7.3	6.5	5.8		
38.0	7.0	6.2	5.6		
40.0	6.7	6.0	5.5		
45.0	6.1	5.5	5.0	4.5	
50.0	5.6	5.1	4.8	4.4	4.2
55.0	5.2	4.8	4.5	4.2	4.1
60.0	4.8	4.6	4.3	4.2	4.1
65.0	4.0	4.4	4.2	4.2	
70.0	2.7	3.3	3.7	4.1	
$\theta(^{\circ})$	25~83	25~83	30~83	45~83	60~83
標準フック	22 ton				
フック重量	880 kg				
巻掛本数	2本				

(単位: ton)

作業半径	10°	20°	30°	45°	60°
22.0 (m)	7.5				
24.0	7.5				
26.0	7.5				
28.0	7.5	7.5			
30.0	7.5	7.5			
32.0	7.5	7.5			
34.0	7.5	7.5	7.5		
36.0	7.5	7.5	7.5		
38.0	7.5	7.5	7.5		
40.0	7.5	7.5	7.5	7.5	
45.0	7.5	7.5	7.5	7.2	6.3
50.0	6.3	7.0	7.4	6.7	6.1
55.0	5.1	5.7	6.3	6.4	5.9
60.0	4.1	4.6	5.0	5.7	
65.0	2.7	3.3	3.9	4.5	
70.0		2.0	2.4		
$\theta(^{\circ})$	25~83	25~83	30~83	45~83	60~83
標準フック	22 ton				
フック重量	880 kg				
巻掛本数	2本				

(単位: ton)

作業半径	10°	20°	30°	45°	60°
24.0 (m)	5.5				
26.0	5.5				
28.0	5.5				
30.0	5.5				
32.0	5.5	5.5			
34.0	5.5	5.5			
36.0	5.5	5.5			
38.0	5.5	5.5	5.5		
40.0	5.5	5.5	5.5		
45.0	5.5	5.5	5.2		
50.0	5.5	5.4	4.9	4.4	
55.0	4.9	5.1	4.7	4.3	4.1
60.0	3.9	4.5	4.5	4.2	4.1
65.0	3.0	3.6	4.1	4.1	4.1
70.0	1.9	2.7	3.2	3.8	
75.0				2.4	
$\theta(^{\circ})$	33~83	33~83	33~83	45~83	60~83
標準フック	22 ton				
フック重量	880 kg				
巻掛本数	2本				

(単位: ton)

作業半径	10°	20°	30°	45°	60°
24.0 (m)	4.5				
26.0	4.5				
28.0	4.5				
30.0	4.5	4.5			
32.0	4.5	4.5			
34.0	4.5	4.5			
36.0	4.5	4.5	4.5		
38.0	4.5	4.5	4.5		
40.0	4.5	4.5	4.5		
45.0	4.5	4.5	4.5	3.7	
50.0	3.8	4.4	4.4	3.6	2.7
55.0	2.8	3.4	3.9	3.5	2.7
60.0	2.0	2.5	2.9	3.5	2.7
65.0		1.7	2.1	2.7	
70.0				1.7	
$\theta(^{\circ})$	45~83	45~83	45~83	45~83	60~83
標準フック	22 ton				
フック重量	880 kg				
巻掛本数	2本				

(単位: ton)

作業半径	10°	20°	30°	45°	60°
26.0 (m)	3.3				
28.0	3.3				
30.0	3.3				
32.0	3.3				
34.0	3.3	3.3			
36.0	3.3	3.3			
38.0	3.3	3.3			
40.0	3.3	3.3	3.1		
45.0	3.3	3.3	3.1		
50.0	3.3	3.1	3.1	2.5	
55.0	2.5	2.8	2.8	2.4	1.6
60.0	1.7	2.3	2.7	2.4	1.6
65.0		1.5	2.1	2.4	1.6
70.0				2.0	1.6
$\theta(^{\circ})$	48~83	48~83	48~83	49~83	60~83
標準フック	22 ton				
フック重量	880 kg				
巻掛本数	2本				

(単位: ton)

ヘビーリフトジブ(12m・54m)

■ B性能

13.6m~50mブーム+4.35m

作業半径	10°	20°	30°	45°	60°
6.0 (m)	84.0				
7.0	83.9				
8.0	82.6	79.3			
9.0	81.4	75.3			
10.0	76.6	71.4	60.9		
11.0	69.5	67.5	58.2		
12.0	62.7	64.1	55.8	43.2	
14.0	52.1	53.2	51.6	40.9	31.9
16.0	44.1	45.0	45.9	39.1	31.2
18.0	37.9	38.6	39.3	37.7	30.9
20.0	32.8	33.3	33.7	34.2	
22.0	28.3	28.7	29.0	29.2	
24.0	24.7	25.0	25.1		
26.0	21.7	21.9			
θ(°)	10~83	20~83	30~83	45~83	60~83
標準フック	150 ton				
フック重量	1850 kg				
巻掛本数	8本				

(単位: ton)

作業半径	10°	20°	30°	45°	60°
9.0 (m)	40.0				
10.0	39.5				
11.0	38.8	34.9			
12.0	38.2	34.4			
14.0	37.0	33.6	30.6		
16.0	36.0	32.8	30.0	26.2	
18.0	33.3	32.2	29.6	26.0	22.6
20.0	29.1	30.2	29.2	25.8	22.6
22.0	24.9	25.8	26.6	25.7	22.6
24.0	21.4	22.1	22.8	23.5	22.6
26.0	18.4	19.1	19.6	20.2	20.5
28.0	16.0	16.5	17.0	17.5	
30.0	13.9	14.4	14.8	15.2	
32.0	12.1	12.5	12.9	13.2	
34.0	10.6	10.9	11.2	11.4	
36.0	9.2	9.5	9.7		
38.0	7.8	8.1	8.3		
40.0	6.6	6.8	6.9		
45.0	3.9				
θ(°)	10~83	20~83	30~83	45~83	60~83
標準フック	65 ton				
フック重量	1000 kg				
巻掛本数	4本				

(単位: ton)

■18.15mブーム+4.35m+12mヘビーリフトジブ B性能

作業半径	10°	20°	30°	45°	60°
7.0 (m)	77.0				
8.0	77.0				
9.0	77.0	77.0			
10.0	75.4	75.3			
11.0	67.3	69.3	60.7		
12.0	60.5	62.3	58.4		
14.0	49.9	51.3	52.7	43.5	34.0
16.0	41.9	43.1	44.2	41.7	33.2
18.0	35.7	36.7	37.6	38.7	32.5
20.0	30.7	31.5	32.2	32.9	32.4
22.0	26.4	27.0	27.5	28.0	
24.0	22.8	23.3	23.7	24.0	
26.0	19.9	20.2	20.5		
28.0	17.4	17.7	17.8		
30.0	15.4	15.5			
32.0	12.4				
θ(°)	10~83	20~83	30~83	45~83	60~83
標準フック	150 ton				
フック重量	1850 kg				
巻掛本数	8本				

(単位: ton)

■40.9mブーム+4.35m+54mヘビーリフトジブ B性能

作業半径	10°	20°	30°	45°	60°
26.0 (m)	3.8				
28.0	3.8				
30.0	3.8				
32.0	3.8				
34.0	3.8	3.7			
36.0	3.8	3.5			
38.0	3.8	3.3			
40.0	3.8	3.2			
45.0	3.4	2.8	2.4		
50.0	3.0	2.5	2.2		
55.0	2.7	2.3	2.0	1.7	
60.0	2.4	2.1	1.9	1.6	1.5
65.0	1.8	1.9	1.7	1.5	1.5
70.0		1.6	1.6	1.5	1.5
75.0				1.5	
θ(°)	49~83	50~83	51~83	56~83	60~83
標準フック	22 ton				
フック重量	880 kg				
巻掛本数	2本				

(単位: ton)

■22.7mブーム+4.35m+12mヘビーリフトジブ B性能

作業半径	10°	20°	30°	45°	60°
8.0 (m)	64.0				
9.0	64.0				
10.0	64.0	64.0			
11.0	64.0	64.0	64.0		
12.0	58.8	60.9	61.8		
14.0	48.1	49.8	51.4	46.9	
16.0	40.1	41.6	42.9	44.6	35.5
18.0	33.9	35.1	36.3	37.6	34.8
20.0	29.0	30.0	30.9	32.0	32.5
22.0	24.9	25.6	26.3	27.1	27.4
24.0	21.3	21.9	22.5	23.1	
26.0	18.4	18.9	19.4	19.8	
28.0	16.0	16.4	16.7	17.0	
30.0	13.9	14.3	14.5		
32.0	12.2	12.4	12.5		
34.0	10.6	10.8			
36.0	9.3				
θ(°)	10~83	20~83	30~83	45~83	60~83
標準フック	65 ton				
フック重量	1000 kg				
巻掛本数	6本				

(単位: ton)

■50mブーム+4.35m+54mヘビーリフトジブ B性能

作業半径	10°	20°	30°	45°
28.0 (m)	2.5			
30.0	2.5			
32.0	2.5			
34.0	2.5			
36.0	2.5	2.5		
38.0	2.5	2.5		
40.0	2.5	2.5		
45.0	2.5	2.5	2.4	
50.0	2.5	2.5	2.2	
55.0	2.2	2.2	2.0	1.5
60.0		2.1	1.9	
65.0			1.8	
θ(°)	58~83	59~83	60~83	60~83
標準フック	22 ton			
フック重量	880 kg			
巻掛本数	2本			

(単位: ton)

ヘビーリフトジブ(21m)

■ B性能

13.6m~50mブーム+4.35m

作業半径	10°	20°	30°	45°	60°
9.0 (m)	55.5				
10.0	54.7				
11.0	53.6				
12.0	52.6				
14.0	48.7	41.4			
16.0	43.5	37.7	33.0		
18.0	39.4	34.6	30.7		
20.0	34.8	32.0	28.7	22.9	
22.0	30.2	29.9	27.0	21.9	17.2
24.0	26.5	27.2	25.6	21.0	16.8
26.0	23.5	24.1	24.3	20.3	16.5
28.0	20.9	21.4	21.9	19.7	
30.0	18.8	19.2	19.6	19.4	
32.0	16.9	17.3	17.5		
34.0	15.3	15.6	15.7		
36.0	14.0				
$\theta(^{\circ})$	10~83	20~83	30~83	45~83	60~83
標準フック	65 ton				
フック重量	1000 kg				
巻掛本数	6本				

(単位: ton)

作業半径	10°	20°	30°	45°	60°
14.0 (m)	27.0				
16.0	27.0	25.0			
18.0	27.0	24.1			
20.0	26.0	23.4	21.1		
22.0	25.1	22.8	20.6		
24.0	23.2	22.2	20.1	17.2	
26.0	20.2	21.3	19.7	17.0	14.3
28.0	17.7	18.7	19.4	16.8	14.2
30.0	15.5	16.4	17.3	16.6	14.2
32.0	13.7	14.5	15.2	16.1	14.2
34.0	12.1	12.8	13.5	14.2	14.2
36.0	10.7	11.3	11.9	12.6	12.9
38.0	9.4	10.0	10.5	11.1	
40.0	8.3	8.9	9.3	9.7	
45.0	5.7	6.2	6.5		
50.0	3.5	3.8	3.9		
$\theta(^{\circ})$	20~83	20~83	30~83	45~83	60~83
標準フック	65 ton				
フック重量	1000 kg				
巻掛本数	4本				

(単位: ton)

作業半径	10°	20°	30°	45°	60°
10.0 (m)	53.0				
11.0	53.0				
12.0	53.0				
14.0	51.8	43.3			
16.0	44.6	39.7	34.3		
18.0	38.3	36.6	32.0		
20.0	33.1	34.0	30.2	24.2	
22.0	28.6	29.7	28.5	23.2	18.1
24.0	24.9	25.8	26.7	22.3	17.7
26.0	21.9	22.7	23.5	21.6	17.4
28.0	19.3	20.0	20.7	21.0	17.2
30.0	17.2	17.8	18.4	19.0	
32.0	15.3	15.9	16.3	16.8	
34.0	13.8	14.2	14.5	14.9	
36.0	12.4	12.7	13.0		
38.0	11.1	11.4	11.5		
40.0	10.0	10.1			
$\theta(^{\circ})$	10~83	20~83	30~83	45~83	60~83
標準フック	65 ton				
フック重量	1000 kg				
巻掛本数	6本				

(単位: ton)

作業半径	10°	20°	30°	45°	60°
16.0 (m)	16.0				
18.0	16.0	16.0			
20.0	16.0	16.0			
22.0	16.0	16.0	16.0		
24.0	16.0	16.0	16.0		
26.0	16.0	16.0	16.0	16.0	
28.0	16.0	16.0	16.0	16.0	14.7
30.0	15.0	15.8	16.0	16.0	14.6
32.0	13.5	14.4	15.2	16.0	14.6
34.0	11.9	12.7	13.5	14.4	14.6
36.0	10.5	11.2	11.9	12.7	13.2
38.0	9.3	9.9	10.5	11.2	11.6
40.0	8.1	8.8	9.3	9.9	
45.0	5.4	6.0	6.5	7.0	
50.0	3.2	3.7	4.0		
$\theta(^{\circ})$	30~83	30~83	35~83	45~83	60~83
標準フック	22 ton				
フック重量	880 kg				
巻掛本数	2本				

(単位: ton)

作業半径	10°	20°	30°	45°	60°
11.0 (m)	44.0				
12.0	44.0				
14.0	44.0				
16.0	43.4	43.9			
18.0	37.1	39.1	34.7		
20.0	32.0	33.6	32.7		
22.0	27.5	28.8	30.1	25.2	
24.0	23.8	24.9	26.0	24.3	19.1
26.0	20.8	21.8	22.7	23.5	18.7
28.0	18.2	19.1	19.9	21.0	18.5
30.0	16.1	16.8	17.6	18.4	18.3
32.0	14.2	14.9	15.5	16.2	16.6
34.0	12.6	13.2	13.7	14.3	
36.0	11.2	11.7	12.1	12.5	
38.0	10.0	10.4	10.7		
40.0	8.9	9.2	9.4		
45.0	6.3				
$\theta(^{\circ})$	10~83	20~83	30~83	45~83	60~83
標準フック	65 ton				
フック重量	1000 kg				
巻掛本数	4本				

(単位: ton)

作業半径	10°	20°	30°	45°	60°
16.0 (m)	9.5				
18.0	9.5				
20.0	9.5	9.5			
22.0	9.5	9.5			
24.0	9.5	9.5	9.5		
26.0	9.5	9.5	9.5	9.1	
28.0	9.5	9.5	9.5	9.0	
30.0	9.5	9.5	9.5	8.9	7.4
32.0	9.5	9.5	9.5	8.8	7.4
34.0	9.2	9.5	9.5	8.8	7.4
36.0	8.4	9.0	9.5	8.8	7.4
38.0	7.6	8.2	8.7	8.8	7.4
40.0	6.9	7.4	7.9	8.5	7.4
45.0	5.0	5.6	6.0	6.5	
50.0	2.8	3.4	3.9	4.4	
$\theta(^{\circ})$	45~83	45~83	45~83	47~83	60~83
標準フック	22 ton				
フック重量	880 kg				
巻掛本数	2本				

(単位: ton)

ヘビーリフトジブ(30m)

■ B性能

13.6m~50mブーム+4.35m

作業半径	10°	20°	30°	45°	60°
14.0 (m)	33.0				
16.0	32.4				
18.0	31.8	29.5			
20.0	30.9	27.1			
22.0	28.2	25.1	22.2		
24.0	26.0	23.3	20.8		
26.0	24.1	21.8	19.6		
28.0	22.0	20.5	18.5	15.0	
30.0	19.8	19.3	17.6	14.3	11.2
32.0	17.9	18.3	16.8	13.8	10.9
34.0	16.3	16.8	16.0	13.3	10.6
36.0	14.9	15.3	15.4	13.0	10.5
38.0	13.6	14.0	14.4	12.7	
40.0	12.5	12.8	13.1	12.5	
$\theta(^{\circ})$	10~83	20~83	30~83	45~83	60~83
標準フック	65 ton				
フック重量	1000 kg				
巻掛本数	4本				

(単位: ton)

作業半径	10°	20°	30°	45°	60°
16.0 (m)	19.0				
18.0	18.6				
20.0	18.4				
22.0	18.2	18.2			
24.0	18.0	18.0			
26.0	17.8	17.6	15.8		
28.0	17.6	17.1	15.4		
30.0	16.9	16.6	15.1	12.7	
32.0	15.1	16.2	14.7	12.5	
34.0	13.4	14.5	14.4	12.3	10.1
36.0	12.0	12.9	13.8	12.1	10.1
38.0	10.7	11.6	12.4	12.0	10.0
40.0	9.6	10.4	11.1	11.9	10.0
45.0	7.1	7.8	8.4	9.1	9.4
50.0	4.9	5.6	6.1	6.6	
55.0	3.1	3.5	3.9		
$\theta(^{\circ})$	20~83	25~83	30~83	45~83	60~83
標準フック	22 ton				
フック重量	880 kg				
巻掛本数	2本				

(単位: ton)

作業半径	10°	20°	30°	45°	60°
14.0 (m)	32.0				
16.0	32.0				
18.0	32.0	30.6			
20.0	32.0	28.3			
22.0	30.1	26.3	23.1		
24.0	26.3	24.5	21.8		
26.0	23.2	23.0	20.6		
28.0	20.7	21.6	19.6	15.8	
30.0	18.5	19.4	18.7	15.2	
32.0	16.6	17.4	17.8	14.7	11.5
34.0	15.0	15.7	16.4	14.2	11.3
36.0	13.5	14.2	14.8	13.8	11.1
38.0	12.2	12.8	13.4	13.5	11.0
40.0	11.1	11.6	12.1	12.7	
45.0	8.8	9.1	9.4		
50.0	6.3				
$\theta(^{\circ})$	10~83	20~83	30~83	45~83	60~83
標準フック	65 ton				
フック重量	1000 kg				
巻掛本数	4本				

(単位: ton)

作業半径	10°	20°	30°	45°	60°
18.0 (m)	11.5				
20.0	11.5				
22.0	11.5				
24.0	11.0	11.0			
26.0	11.0	11.0			
28.0	11.0	11.0	11.0		
30.0	11.0	11.0	11.0		
32.0	11.0	11.0	11.0	11.0	
34.0	11.0	11.0	11.0	11.0	
36.0	11.0	11.0	11.0	11.0	10.2
38.0	10.2	10.8	11.0	11.0	10.2
40.0	9.1	10.0	10.8	11.0	10.1
45.0	6.5	7.4	8.1	9.0	9.5
50.0	4.3	5.1	5.8	6.6	
55.0	2.4	3.1	3.7	4.2	
$\theta(^{\circ})$	36~83	38~83	38~83	45~83	60~83
標準フック	22 ton				
フック重量	880 kg				
巻掛本数	2本				

(単位: ton)

作業半径	10°	20°	30°	45°	60°
14.0 (m)	30.0				
16.0	30.0				
18.0	30.0				
20.0	30.0	29.3			
22.0	29.0	27.3			
24.0	25.2	25.6	22.4		
26.0	22.1	23.5	21.2		
28.0	19.5	20.8	20.2	16.4	
30.0	17.3	18.5	19.3	15.8	
32.0	15.4	16.5	17.4	15.3	12.0
34.0	13.8	14.7	15.6	14.8	11.7
36.0	12.4	13.2	14.0	14.4	11.5
38.0	11.1	11.8	12.5	13.5	11.4
40.0	10.0	10.6	11.3	12.0	11.3
45.0	7.6	8.1	8.5	9.0	
50.0	5.6	5.9	6.2		
$\theta(^{\circ})$	15~83	20~83	30~83	45~83	60~83
標準フック	65 ton				
フック重量	1000 kg				
巻掛本数	4本				

(単位: ton)

作業半径	10°	20°	30°	45°	60°
20.0 (m)	6.6				
22.0	6.6				
24.0	6.6	6.6			
26.0	6.6	6.6			
28.0	6.6	6.6	6.6		
30.0	6.6	6.6	6.6		
32.0	6.6	6.6	6.6		
34.0	6.6	6.6	6.6	5.8	
36.0	6.6	6.6	6.6	5.8	
38.0	6.3	6.5	6.6	5.7	4.5
40.0	6.0	6.3	6.5	5.6	4.5
45.0	5.1	5.7	6.0	5.6	4.5
50.0	3.7	4.4	4.9	5.6	4.5
55.0		2.7	3.4	4.1	
$\theta(^{\circ})$	50~83	51~83	51~83	52~83	60~83
標準フック	22 ton				
フック重量	880 kg				
巻掛本数	2本				

(単位: ton)

ヘビーリフトジブ(40m・47m)

■ B性能

31.8m~50mブーム+4.35m

作業半径	10°	20°	30°	45°	60°
20.0 (m)	11.0				
22.0	11.0				
24.0	11.0				
26.0	11.0	11.0			
28.0	11.0	11.0			
30.0	11.0	11.0			
32.0	11.0	11.0	10.7		
34.0	11.0	11.0	10.2		
36.0	11.0	11.0	9.7		
38.0	11.0	10.7	9.3	7.8	
40.0	10.7	10.2	8.9	7.5	
45.0	8.3	9.1	8.0	7.0	6.2
50.0	6.3	7.1	7.4	6.5	6.0
55.0	4.5	5.3	6.0	6.2	5.9
60.0	3.0	3.6	4.2	4.8	
65.0	1.7	2.2	2.5		
$\theta(^{\circ})$	22~83	25~83	30~83	45~83	60~83
標準フック	22 ton				
フック重量	880 kg				
巻掛本数	2本				

(単位: ton)

作業半径	10°	20°	30°	45°	60°
22.0 (m)	7.5				
24.0	7.5				
26.0	7.5				
28.0	7.5				
30.0	7.5	7.3			
32.0	7.5	7.0			
34.0	7.5	6.7			
36.0	7.3	6.5	5.8		
38.0	7.0	6.2	5.6		
40.0	6.7	6.0	5.5		
45.0	6.1	5.5	5.0	4.5	
50.0	5.6	5.1	4.8	4.4	4.2
55.0	5.1	4.8	4.5	4.2	4.1
60.0	3.5	4.4	4.3	4.2	4.1
65.0	2.2	2.9	3.6	4.2	
70.0		1.7	2.1		
$\theta(^{\circ})$	26~83	30~83	32~83	45~83	60~83
標準フック	22 ton				
フック重量	880 kg				
巻掛本数	2本				

(単位: ton)

作業半径	10°	20°	30°	45°	60°
22.0 (m)	7.5				
24.0	7.5				
26.0	7.5				
28.0	7.5	7.5			
30.0	7.5	7.5			
32.0	7.5	7.5			
34.0	7.5	7.5	7.5		
36.0	7.5	7.5	7.5		
38.0	7.5	7.5	7.5		
40.0	7.5	7.5	7.5	7.5	
45.0	7.5	7.5	7.5	7.2	6.3
50.0	5.6	6.7	7.4	6.7	6.1
55.0	3.8	4.7	5.6	6.4	5.9
60.0	2.2	3.0	3.8	4.7	
65.0		1.6	2.2	2.8	
$\theta(^{\circ})$	40~83	40~83	40~83	45~83	60~83
標準フック	22 ton				
フック重量	880 kg				
巻掛本数	2本				

(単位: ton)

作業半径	10°	20°	30°	45°	60°
24.0 (m)	5.5				
26.0	5.5				
28.0	5.5				
30.0	5.5				
32.0	5.5	5.5			
34.0	5.5	5.5			
36.0	5.5	5.5			
38.0	5.5	5.5	5.5		
40.0	5.5	5.5	5.5		
45.0	5.5	5.5	5.2		
50.0	5.5	5.4	4.9	4.4	
55.0	4.3	5.1	4.7	4.3	4.1
60.0	2.8	3.8	4.5	4.2	4.1
65.0	1.5	2.3	3.1	4.1	4.1
70.0			1.7	2.5	
$\theta(^{\circ})$	45~83	45~83	46~83	46~83	60~83
標準フック	22 ton				
フック重量	880 kg				
巻掛本数	2本				

(単位: ton)

作業半径	10°	20°	30°	45°	60°
24.0 (m)	4.5				
26.0	4.5				
28.0	4.5				
30.0	4.5	4.5			
32.0	4.5	4.5			
34.0	4.5	4.5			
36.0	4.5	4.5	4.5		
38.0	4.5	4.5	4.5		
40.0	4.5	4.5	4.5		
45.0	4.5	4.5	4.5	3.7	
50.0	3.8	4.4	4.4	3.6	2.7
55.0	2.8	3.4	3.9	3.5	2.7
60.0		2.5	2.9	3.5	2.7
65.0				2.7	
$\theta(^{\circ})$	54~83	54~83	54~83	57~83	60~83
標準フック	22 ton				
フック重量	880 kg				
巻掛本数	2本				

(単位: ton)

作業半径	10°	20°	30°	45°	60°
26.0 (m)	3.3				
28.0	3.3				
30.0	3.3				
32.0	3.3				
34.0	3.3	3.3			
36.0	3.3	3.3			
38.0	3.3	3.3			
40.0	3.3	3.3	3.1		
45.0	3.3	3.3	3.1		
50.0	3.3	3.1	3.1	2.5	
55.0	2.5	2.8	2.8	2.4	1.6
60.0	1.7	2.3	2.7	2.4	1.6
65.0			2.1	2.4	1.6
70.0				2.0	1.6
$\theta(^{\circ})$	55~83	56~83	56~83	57~83	60~83
標準フック	22 ton				
フック重量	880 kg				
巻掛本数	2本				

(単位: ton)

ヘビーリフトジブ(12m・54m)

■ C性能

13.6m~50mブーム+4.35m

■13.6mブーム+4.35m+12mヘビーリフトジブ

C性能

作業半径	10°	20°	30°	45°	60°
6.0 (m)	84.0				
7.0	83.9				
8.0	82.6	79.3			
9.0	79.7	75.3			
10.0	70.5	71.4	60.9		
11.0	63.1	64.6	58.2		
12.0	56.8	58.2	55.8	43.2	
14.0	45.1	46.2	47.2	40.9	31.9
16.0	36.4	37.3	38.1	39.0	31.2
18.0	30.2	30.8	31.4	32.2	30.9
20.0	25.5	26.0	26.4	26.9	
22.0	21.8	22.2	22.5	22.7	
24.0	18.8	19.1	19.3		
26.0	16.4	16.5			
θ(°)	10~83	20~83	30~83	45~83	60~83
標準フック	150 ton				
フック重量	1850 kg				
巻掛本数	8本				

(単位: ton)

■31.8mブーム+4.35m+12mヘビーリフトジブ

C性能

作業半径	10°	20°	30°	45°	60°
9.0 (m)	40.0				
10.0	39.5				
11.0	38.8	34.9			
12.0	38.2	34.4			
14.0	37.0	33.6	30.6		
16.0	32.9	32.8	30.0	26.2	
18.0	26.7	27.9	29.0	26.0	22.6
20.0	22.1	23.1	24.0	25.1	22.6
22.0	18.4	19.3	20.0	21.0	21.5
24.0	15.5	16.2	16.9	17.6	18.0
26.0	13.1	13.7	14.3	14.9	15.2
28.0	11.1	11.6	12.1	12.6	
30.0	9.4	9.9	10.2	9.5	
32.0	7.7	8.2	8.6	8.9	
34.0	6.2	6.7	7.0	7.3	
36.0	4.9	5.3	5.5		
38.0	3.7	4.0	4.2		
θ(°)	15~83	20~83	30~83	45~83	60~83
標準フック	65 ton				
フック重量	1000 kg				
巻掛本数	4本				

(単位: ton)

■18.15mブーム+4.35m+12mヘビーリフトジブ

C性能

作業半径	10°	20°	30°	45°	60°
7.0 (m)	77.0				
8.0	77.0				
9.0	77.0	77.0			
10.0	68.4	70.6			
11.0	60.9	62.8	60.7		
12.0	54.6	56.4	58.1		
14.0	43.0	44.4	45.7	43.5	34.0
16.0	34.4	35.5	36.5	37.8	33.2
18.0	28.2	29.1	29.9	30.9	31.5
20.0	23.5	24.2	24.9	25.6	26.0
22.0	19.9	20.4	21.0	21.5	
24.0	16.9	17.4	17.8	18.1	
26.0	14.5	14.9	15.2		
28.0	12.5	12.8	12.9		
30.0	10.8	11.0			
32.0	9.4				
θ(°)	10~83	20~83	30~83	45~83	60~83
標準フック	150 ton				
フック重量	1850 kg				
巻掛本数	8本				

(単位: ton)

■40.9mブーム+4.35m+54mヘビーリフトジブ

C性能

作業半径	10°	20°	30°	45°	60°
26.0 (m)	3.8				
28.0	3.8				
30.0	3.8				
32.0	3.8				
34.0	3.8	3.7			
36.0	3.8	3.5			
38.0	3.8	3.3			
40.0	3.8	3.2			
45.0	3.4	2.8	2.4		
50.0	3.0	2.5	2.2		
55.0		2.3	2.0	1.7	
60.0			1.9	1.6	1.5
65.0				1.5	1.5
70.0					1.5
θ(°)	60~83	60~83	62~83	64~83	64~83
標準フック	22 ton				
フック重量	880 kg				
巻掛本数	2本				

(単位: ton)

■22.7mブーム+4.35m+12mヘビーリフトジブ

C性能

作業半径	10°	20°	30°	45°	60°
8.0 (m)	64.0				
9.0	64.0				
10.0	64.0	64.0			
11.0	59.1	61.4	63.6		
12.0	52.9	54.9	56.9		
14.0	41.3	42.9	44.5	46.4	
16.0	32.8	34.1	35.3	36.9	35.5
18.0	26.6	27.7	28.7	29.9	30.7
20.0	22.0	22.9	23.7	24.7	25.2
22.0	18.4	19.1	19.8	20.5	20.9
24.0	15.4	16.1	16.6	17.2	
26.0	13.1	13.6	14.0	14.4	
28.0	11.1	11.5	11.8	12.1	
30.0	9.4	9.7	10.0		
32.0	7.8	8.1	8.2		
34.0	6.3	6.5			
36.0	5.0				
θ(°)	10~83	20~83	30~83	45~83	60~83
標準フック	65 ton				
フック重量	1000 kg				
巻掛本数	6本				

(単位: ton)

■50mブーム+4.35m+54mヘビーリフトジブ

C性能

作業半径	10°	20°	30°	45°
28.0 (m)	2.5			
30.0	2.5			
32.0	2.5			
34.0	2.5			
36.0	2.5	2.5		
38.0	2.5	2.5		
40.0	2.5	2.5		
45.0	2.5	2.5	2.4	
50.0		2.5	2.2	
55.0			2.0	1.5
θ(°)	66~83	67~83	69~83	69~83
標準フック	22 ton			
フック重量	880 kg			
巻掛本数	2本			

(単位: ton)

ヘビーリフトジブ(21m)

■ C 性能

13.6m~50mブーム+4.35m

作業半径	10°	20°	30°	45°	60°
9.0 (m)	55.5				
10.0	54.7				
11.0	53.6				
12.0	52.6				
14.0	47.7	41.4			
16.0	38.8	37.7	33.0		
18.0	32.3	33.5	30.7		
20.0	27.5	28.5	28.7	22.9	
22.0	23.7	24.5	25.3	21.9	17.2
24.0	20.6	21.3	22.0	21.0	16.8
26.0	18.1	18.7	19.3	20.1	16.5
28.0	16.0	16.5	17.0	17.6	
30.0	14.2	14.7	15.0	15.4	
32.0	12.7	13.0	13.3		
34.0	11.4	11.6	11.8		
36.0	10.3				
$\theta(^{\circ})$	10~83	20~83	30~83	45~83	60~83
標準フック	65 ton				
フック重量	1000 kg				
巻掛本数	6本				

(単位: ton)

作業半径	10°	20°	30°	45°	60°
14.0 (m)	27.0				
16.0	27.0	25.0			
18.0	27.0	24.1			
20.0	24.1	23.4	21.1		
22.0	20.4	21.8	20.6		
24.0	17.3	18.6	19.8	17.2	
26.0	14.8	16.0	17.0	17.0	14.3
28.0	12.7	13.8	14.7	15.9	14.2
30.0	11.0	11.9	12.7	13.8	14.2
32.0	9.5	10.3	11.0	11.9	12.5
34.0	8.1	8.9	9.5	10.3	10.7
36.0	6.8	7.6	8.2	8.9	9.2
38.0	5.6	6.4	7.0	7.6	
40.0	4.5	5.2	5.8	6.3	
45.0			3.0		
$\theta(^{\circ})$	33~83	34~83	35~83	45~83	60~83
標準フック	65 ton				
フック重量	1000 kg				
巻掛本数	4本				

(単位: ton)

作業半径	10°	20°	30°	45°	60°
10.0 (m)	53.0				
11.0	53.0				
12.0	53.0				
14.0	46.0	43.3			
16.0	37.1	38.9			
18.0	30.7	32.2	32.0		
20.0	25.8	27.1	28.4	24.2	
22.0	22.1	23.2	24.2	23.2	18.1
24.0	19.0	20.0	20.9	22.1	17.7
26.0	16.5	17.3	18.1	19.1	17.4
28.0	14.4	15.1	15.8	16.6	17.2
30.0	12.6	13.3	13.8	14.5	
32.0	11.1	11.6	12.1	12.6	
34.0	9.8	10.2	10.6	10.9	
36.0	8.7	9.0	9.3		
38.0	7.7	7.9	8.0		
40.0	6.7	6.8			
$\theta(^{\circ})$	10~83	20~83	30~83	45~83	60~83
標準フック	65 ton				
フック重量	1000 kg				
巻掛本数	6本				

(単位: ton)

作業半径	10°	20°	30°	45°	60°
16.0 (m)	16.0				
18.0	16.0	16.0			
20.0	16.0	16.0			
22.0	16.0	16.0	16.0		
24.0	16.0	16.0	16.0		
26.0	14.7	15.9	16.0	16.0	
28.0	12.6	13.7	14.7	16.0	14.7
30.0	10.8	11.8	12.7	13.9	14.6
32.0	9.3	10.2	11.0	12.0	12.7
34.0	7.9	8.8	9.5	10.4	11.0
36.0	6.6	7.5	8.2	9.0	9.5
38.0	5.3	6.2	7.0	7.7	8.1
40.0	4.2	5.0	5.8	6.5	
45.0	1.9	2.5	3.1	3.6	
$\theta(^{\circ})$	47~83	47~83	48~83	48~83	60~83
標準フック	22 ton				
フック重量	880 kg				
巻掛本数	2本				

(単位: ton)

作業半径	10°	20°	30°	45°	60°
11.0 (m)	44.0				
12.0	44.0				
14.0	44.0				
16.0	36.0	38.1			
18.0	29.6	31.4	33.1		
20.0	24.8	26.3	27.8		
22.0	21.0	22.3	23.6	25.2	
24.0	17.9	19.1	20.2	21.6	19.1
26.0	15.4	16.4	17.4	18.6	18.7
28.0	13.3	14.2	15.0	16.1	16.8
30.0	11.5	12.3	13.0	13.9	14.4
32.0	10.0	10.7	11.3	12.0	12.4
34.0	8.7	9.3	9.8	10.3	
36.0	7.5	8.0	8.4		
38.0	6.3	6.8	7.2		
40.0	5.2	5.6			
$\theta(^{\circ})$	10~83	20~83	30~83	45~83	60~83
標準フック	65 ton				
フック重量	1000 kg				
巻掛本数	4本				

(単位: ton)

作業半径	10°	20°	30°	45°	60°
16.0 (m)	9.5				
18.0	9.5				
20.0	9.5	9.5			
22.0	9.5	9.5			
24.0	9.5	9.5	9.5		
26.0	9.5	9.5	9.5	9.1	
28.0	9.5	9.5	9.5	9.0	
30.0	9.5	9.5	9.5	8.9	7.4
32.0	8.9	9.5	9.5	8.8	7.4
34.0	7.5	8.5	9.3	8.8	7.4
36.0	6.1	7.2	8.0	8.8	7.4
38.0	4.9	5.9	6.7	7.7	7.4
40.0	3.8	4.7	5.5	6.4	6.9
45.0		2.2	2.8	3.6	
$\theta(^{\circ})$	56~83	56~83	58~83	59~83	60~83
標準フック	22 ton				
フック重量	880 kg				
巻掛本数	2本				

(単位: ton)

ヘビーリフトジブ(30m)

■ C性能

13.6m~50mブーム+4.35m

作業半径	10°	20°	30°	45°	60°
14.0 (m)	33.0				
16.0	32.4				
18.0	31.8	29.5			
20.0	28.8	27.1			
22.0	24.9	25.1	22.2		
24.0	21.8	22.8	20.8		
26.0	19.3	20.1	19.6		
28.0	17.1	17.9	18.5	15.0	
30.0	15.3	16.0	16.7	14.3	11.2
32.0	13.7	14.3	14.9	13.8	10.9
34.0	12.4	12.9	13.4	13.3	10.6
36.0	11.2	11.6	12.1	12.7	10.5
38.0	10.1	10.5	10.9	11.4	
40.0		9.5	9.8	10.1	
$\theta(^{\circ})$	10~83	20~83	30~83	45~83	60~83
標準フック	65 ton				
フック重量	1000 kg				
巻掛本数	4本				

(単位: ton)

作業半径	10°	20°	30°	45°	60°
16.0 (m)	19.0				
18.0	18.6				
20.0	18.4				
22.0	18.2	18.2			
24.0	18.0	18.0			
26.0	16.4	17.6	15.8		
28.0	14.2	15.6	15.4		
30.0	12.4	13.7	14.9	12.7	
32.0	10.8	12.0	13.1	12.5	
34.0	9.5	10.5	11.5	12.3	10.1
36.0	8.3	9.2	10.1	11.3	10.1
38.0	7.2	8.1	8.9	10.0	10.0
40.0	6.1	7.1	7.8	8.8	9.4
45.0	3.7	4.6	5.3	6.2	6.5
50.0		2.5	3.0	3.6	
$\theta(^{\circ})$	38~83	38~83	38~83	45~83	60~83
標準フック	22 ton				
フック重量	880 kg				
巻掛本数	2本				

(単位: ton)

作業半径	10°	20°	30°	45°	60°
14.0 (m)	32.0				
16.0	32.0				
18.0	32.0	30.6			
20.0	27.5	28.3			
22.0	23.6	25.1	23.1		
24.0	20.5	21.8	21.8		
26.0	17.9	19.1	20.2		
28.0	15.8	16.8	17.8	15.8	
30.0	13.9	14.9	15.8	15.2	
32.0	12.4	13.2	14.0	14.7	11.5
34.0	11.0	11.7	12.5	13.4	11.3
36.0	9.8	10.5	11.1	12.0	11.1
38.0	8.8	9.3	9.9	10.6	11.0
40.0	7.8	8.3	8.8	9.4	
45.0	5.8	6.2	6.5		
50.0	4.0				
$\theta(^{\circ})$	10~83	20~83	30~83	45~83	60~83
標準フック	65 ton				
フック重量	1000 kg				
巻掛本数	4本				

(単位: ton)

作業半径	10°	20°	30°	45°	60°
18.0 (m)	11.5				
20.0	11.5				
22.0	11.5				
24.0	11.0	11.0			
26.0	11.0	11.0			
28.0	11.0	11.0	11.0		
30.0	11.0	11.0	11.0		
32.0	10.3	11.0	11.0	11.0	
34.0	9.0	10.1	11.0	11.0	
36.0	7.7	8.8	9.8	11.0	10.2
38.0	6.5	7.7	8.6	9.8	10.2
40.0	5.4	6.6	7.5	8.6	9.4
45.0	3.0	4.0	5.0	6.0	6.6
50.0			2.7	3.5	
$\theta(^{\circ})$	52~83	52~83	54~83	57~83	60~83
標準フック	22 ton				
フック重量	880 kg				
巻掛本数	2本				

(単位: ton)

作業半径	10°	20°	30°	45°	60°
14.0 (m)	30.0				
16.0	30.0				
18.0	30.0				
20.0	26.3	28.4			
22.0	22.5	24.2			
24.0	19.3	20.9	22.4		
26.0	16.8	18.2	19.5		
28.0	14.6	15.9	17.1	16.4	
30.0	12.8	13.9	15.0	15.8	
32.0	11.2	12.2	13.2	14.6	12.0
34.0	9.9	10.8	11.7	12.9	11.7
36.0	8.7	9.5	10.3	11.3	11.5
38.0	7.6	8.4	9.1	10.0	10.6
40.0	6.6	7.3	8.0	8.8	9.2
45.0	4.3	5.0	5.5	6.1	
$\theta(^{\circ})$	24~83	26~83	30~83	45~83	60~83
標準フック	65 ton				
フック重量	1000 kg				
巻掛本数	4本				

(単位: ton)

作業半径	10°	20°	30°	45°	60°
20.0 (m)	6.6				
22.0	6.6				
24.0	6.6	6.6			
26.0	6.6	6.6			
28.0	6.6	6.6	6.6		
30.0	6.6	6.6	6.6		
32.0	6.6	6.6	6.6		
34.0	6.6	6.6	6.6	5.8	
36.0	6.6	6.6	6.6	5.8	
38.0	6.0	6.5	6.6	5.7	4.5
40.0	4.9	6.2	6.5	5.6	4.5
45.0		3.6	4.6	5.6	4.5
50.0				3.4	4.0
$\theta(^{\circ})$	58~83	59~83	60~83	60~83	60~83
標準フック	22 ton				
フック重量	880 kg				
巻掛本数	2本				

(単位: ton)

ヘビーリフトジブ(40m・47m)

■ C性能

31.8m~50mブーム+4.35m

作業半径	10°	20°	30°	45°	60°
20.0 (m)	11.0				
22.0	11.0				
24.0	11.0				
26.0	11.0	11.0			
28.0	11.0	11.0			
30.0	11.0	11.0			
32.0	11.0	11.0	10.7		
34.0	10.6	11.0	10.2		
36.0	9.4	10.7	9.7		
38.0	8.3	9.5	9.3	7.8	
40.0	7.4	8.4	8.9	7.5	
45.0	5.2	6.3	7.1	7.0	6.2
50.0	3.3	4.3	5.2	6.2	6.0
55.0	1.7	2.5	3.3	4.2	4.7
60.0			1.6	2.3	
θ(°)	40~83	42~83	42~83	45~83	60~83
標準フック	22 ton				
フック重量	880 kg				
巻掛本数	2本				

(単位: ton)

作業半径	10°	20°	30°	45°	60°
22.0 (m)	7.5				
24.0	7.5				
26.0	7.5				
28.0	7.5				
30.0	7.5	7.3			
32.0	7.5	7.0			
34.0	7.5	6.7			
36.0	7.3	6.5	5.8		
38.0	7.0	6.2	5.6		
40.0	6.7	6.0	5.5		
45.0	5.7	5.5	5.0	4.5	
50.0	3.8	5.0	4.8	4.4	4.2
55.0	2.3	3.3	4.3	4.2	4.1
60.0		1.8	2.6	3.7	4.1
65.0				2.0	
θ(°)	50~83	50~83	50~83	53~83	60~83
標準フック	22 ton				
フック重量	880 kg				
巻掛本数	2本				

(単位: ton)

作業半径	10°	20°	30°	45°	60°
22.0 (m)	7.5				
24.0	7.5				
26.0	7.5				
28.0	7.5	7.5			
30.0	7.5	7.5			
32.0	7.5	7.5			
34.0	7.5	7.5	7.5		
36.0	7.5	7.5	7.5		
38.0	7.5	7.5	7.5		
40.0	6.8	7.5	7.5	7.5	
45.0	4.4	5.7	6.8	7.2	6.3
50.0	2.5	3.6	4.7	6.0	6.1
55.0		1.9	2.8	4.0	4.7
60.0				2.1	
θ(°)	53~83	53~83	54~83	57~83	60~83
標準フック	22 ton				
フック重量	880 kg				
巻掛本数	2本				

(単位: ton)

作業半径	10°	20°	30°	45°	60°
24.0 (m)	5.5				
26.0	5.5				
28.0	5.5				
30.0	5.5				
32.0	5.5	5.5			
34.0	5.5	5.5			
36.0	5.5	5.5			
38.0	5.5	5.5	5.5		
40.0	5.5	5.5	5.5		
45.0	5.0	5.5	5.2		
50.0	3.0	4.4	4.9	4.4	
55.0		2.6	3.8	4.3	4.1
60.0			2.1	3.4	4.1
65.0				1.7	2.3
θ(°)	57~83	58~83	59~83	59~83	60~83
標準フック	22 ton				
フック重量	880 kg				
巻掛本数	2本				

(単位: ton)

作業半径	10°	20°	30°	45°	60°
24.0 (m)	4.5				
26.0	4.5				
28.0	4.5				
30.0	4.5	4.5			
32.0	4.5	4.5			
34.0	4.5	4.5			
36.0	4.5	4.5	4.5		
38.0	4.5	4.5	4.5		
40.0	4.5	4.5	4.5		
45.0	3.8	4.5	4.5	3.7	
50.0	1.8	3.1	4.3	3.6	2.7
55.0			2.4	3.5	2.7
60.0				1.9	2.5
θ(°)	58~83	59~83	62~83	62~83	64~83
標準フック	22 ton				
フック重量	880 kg				
巻掛本数	2本				

(単位: ton)

作業半径	10°	20°	30°	45°	60°
26.0 (m)	3.3				
28.0	3.3				
30.0	3.3				
32.0	3.3				
34.0	3.3	3.3			
36.0	3.3	3.3			
38.0	3.3	3.3			
40.0	3.3	3.3	3.1		
45.0	3.3	3.3	3.1		
50.0		3.1	3.1	2.5	
55.0			2.8	2.4	1.6
60.0				2.4	1.6
θ(°)	64~83	65~83	65~83	67~83	67~83
標準フック	22 ton				
フック重量	880 kg				
巻掛本数	2本				

(単位: ton)

KATO 株式会社 加藤製作所

本社 東京都品川区東大井1丁目9番37号 ☎140-0011 ☎03(3458)1111番(大代表)

東京支店	東京都品川区東大井1丁目9番37号	☎140-0011	☎03(3458)1112番(代表)
新潟営業所	新潟市南笹口1丁目1番54号(明治生命新潟駅前ビル)	☎950-0912	☎025(247)8326番(代表)
高崎営業所	高崎市相生町1番地1(八十二銀行高崎ビル)	☎370-0811	☎027(325)1311番(代表)
札幌支店	札幌市白石区新水7条2丁目7番1号(札幌流通倉庫東ビル)	☎003-0807	☎011(837)5211番(代表)
帯広営業所	帯広市大通南11丁目18番地1号(明治生命帯広ビル)	☎080-0010	☎0155(25)7211番(代表)
仙台支店	仙台市青葉区二日町3番10号(グラン・シャリオビル)	☎980-0802	☎022(222)4896番(代表)
盛岡営業所	盛岡市中央通3丁目3番26号(盛岡鹿島ビル)	☎020-0021	☎019(652)1191番(代表)
秋田営業所	秋田市山王2丁目1番60号(アイデックスビル)	☎010-0951	☎018(863)5001番(代表)
郡山営業所	郡山市中町1番22号(郡山大同生命ビル)	☎963-8004	☎024(932)1811番(代表)
埼玉支店	大宮市東大成町1丁目497番地MJ森業ビル	☎330-0037	☎048(651)1135番(代表)
宇都宮営業所	宇都宮市一条3丁目1番19号(大東京火災宇都宮ビル)	☎320-0821	☎028(635)6121番(代表)
千葉支店	千葉市稲毛区稲毛東1丁目7番8号	☎263-0031	☎043(242)7746番(代表)
水戸営業所	水戸市五軒町1丁目3番34号(会計ビル)	☎310-0063	☎029(227)5051番(代表)
横浜支店	横浜市神奈川区沢渡1番地2(高島台第2ビル)	☎221-0844	☎045(311)7992番(代表)
静岡営業所	静岡市石田1丁目1番46号(静岡信用金庫石田ビル)	☎422-8042	☎054(286)3141番(代表)
名古屋支店	名古屋市東区葵3丁目23番3号(第14オーシャンビル)	☎461-0004	☎052(934)0588番(代表)
富山営業所	富山市堤町通り1丁目3番6号(日産火災富山ビル)	☎930-0046	☎076(493)1833番(代表)
岐阜営業所	岐阜市加納栄町通6丁目32番1号(日動岐阜ビル)	☎500-8455	☎058(274)8123番(代表)
大阪支店	大阪市淀川区西中島2丁目3番20号	☎532-0011	☎06(6303)1131番(大代表)
京滋営業所	大津市におの浜2丁目1番48号(におの浜森田ビル)	☎520-0801	☎077(524)8001番(代表)
姫路営業所	姫路市南駅前町92番地(USビル)	☎670-0962	☎0792(82)0155番(代表)
中国支店	広島市西区南観音7丁目16番15号(タワー川村ビル)	☎733-0035	☎082(295)0300番(代表)
岡山営業所	岡山市磨屋町9番18号(岡山県農業会館ビル)	☎700-0826	☎086(231)1291番(代表)
徳山営業所	徳山市御幸通1丁目5番地(往友生命徳山ビル)	☎745-0034	☎0834(22)2426番(代表)
四国支店	高松市唐屋町8番地1(富士火災高松ビル)	☎760-0026	☎087(822)7731番(代表)
松山営業所	松山市花園町3番地21(朝日生命松山南堤端ビル)	☎790-0005	☎089(943)5240番(代表)
九州支店	福岡市博多区東比恵3丁目12番16号(東比恵スクエアビル)	☎812-0007	☎092(474)0122番(代表)
大分営業所	大分市都町1丁目1番1号(太陽生命大分ビル)	☎870-0034	☎097(536)6650番(代表)
鹿児島営業所	鹿児島市上之園町24番2(ボイス鹿児島ビル)	☎890-0052	☎099(258)3326番(代表)
沖縄営業所	那覇市松山2丁目1番12号(玉キ米屋ビル)	☎900-0032	☎098(868)9461番(代表)

※本カタログに記載されております性能ならびに仕様は、改良などによりお届けいたします製品と異なる場合がありますので、あらかじめご了承ください。

お問い合わせは…