



RUGGED AND DEPENDABLE

A COMPLETE SOLUTION

- ▶ Emissions-certified 348 HP Cummins diesel engine
- ▶ 5.9 to 7.7 cu. yard bucket available
- ▶ Accepts a wide assortment of attachments to handle many jobs
- ▶ Ride Control option provides stable load handling
- ▶ Single hydraulic control option for easy operation
- ▶ Automatic powershift transmission with four forward and reverse speeds
- ▶ Outboard-mounted, dual circuit wet disc brakes for reliability and long service life
- ▶ Torque-proportioning differentials for longer tire life and less wheel spin
- ▶ Wide front fenders with mud flaps, standard
- ▶ Transmission has helical gears which reduce noise level and vibration
- ▶ Autobrake, standard, protects the transmission from overspeeding and abrupt directional changes.
- ▶ Automatic Reversible Cooling Fan with manual override, standard
- ▶ Adjustable declutch allows the operator to adjust the declutch to various operating conditions
- ▶ Air conditioning, standard
- ▶ MODM (Machine Operation Diagnostic Module) provides essential operations and diagnostic information in an easy-to-read LCD display

**EASY TO OPERATE.
EASY TO MAINTAIN.
EASY TO DO BUSINESS WITH.**

POWER TO SPARE.

The 95ZV-2 features a redesigned ROPS cab with operator-friendly features. The operator may now customize settings and make adjustments to the loader controls to work more efficiently in the current operating conditions or environment. New features like the Adjustable Declutch, Dual Boom Kickout Control, Idle Management System, Dual Mode Engine Switch, and ELS (Efficient Loading System) allow the operator to make adjustments from the comfort of the cab increasing productivity and efficiency. Options such as the Limited Slip Differentials allow the operator additional controls to adapt the 95ZV-2 loader to the working conditions.



COMFORTABLE, EFFICIENT, SAFE.

The 95ZV-2 features standard air conditioning and heater. The Air Ride seat is standard. The operator compartment has increased leg room. Options such as the F-R Directional Switch, Ride control, and Single Lever Hydraulic Control allow the operator additional ease of operation and comfort.

VERSATILE, RELIABLE, STRONG.

Like all Kawasaki loaders, the 95ZV-2 has a 45+ year heritage of strength and reliability.

The 95ZV-2 is available with several buckets, bucket teeth, and bolt-on cutting edge combinations. A third spool valve is available to handle a number of attachments and extend the wheel loader's versatility.

Features such as the outboard-mounted, sealed wet disc brakes are designed for long life and easy access and overhaul. Spin-on filters, grouped grease fittings, sealed universal joints, all provide easy field maintenance. The new MODM (Machine Operation Diagnostic Module) provides essential operational and diagnostic information in an easy-to-read LCD display. The optional K-LINK system allows location, system alarm sensors, and all major machine performance data to be electronically transmitted to cell phones, fax and e-mail for real-time equipment management.

FAILURE IS NOT AN OPTION.

Kawasaki is dedicated to keeping your wheel loader up and running, even in the most challenging situations. Starting with the KLEW (Kawasaki Loaders Early Warning) Oil Analysis System, designed to eliminate unnecessary maintenance and downtime, to our 24-hour parts shipment service, and our extensive rebuild program, Kawasaki has the expertise and experience to respond quickly to your needs.



Kawasaki and their dealer organization offer comprehensive support and service programs designed to keep you on the job.

POWER AND PERFORMANCE PROVIDE UNMATCHED PRODUCTIVITY



COMPUTER CONTROLLED ENGINE

The Engine Control Module (ECM) provides a wide range of operating data and feedback to assist in analyzing diagnostics and troubleshooting. Cummins offers diagnostic tools to allow technicians to quickly recover engine information for fast, accurate analysis.

EPA Tier III emission standards are met by using the Cummins In-Cylinder Advanced Combustion Solution, a proven technology that keeps the overall design simple and less costly to maintain.

- Extended Oil Change intervals
- Increased Peak Torque provides improved performance, better rimpull.
- Reduced RPM reduces fuel consumption without loss of operating efficiency.
- Idle Management System allows for lower engine speed when idling for extended periods to conserve fuel. It also increases engine RPM to reduce engine warm-up time in cold temperatures.

WORLD-CLASS ENGINES

- 348 HP Cummins QSX15 diesel
- Certified Tier III Emissions
- Engineered for longer service life
- Reliable and fuel efficient
- Extensive distribution system
- 24 volt battery system for reserve power
- Turbocharger with aftercooler

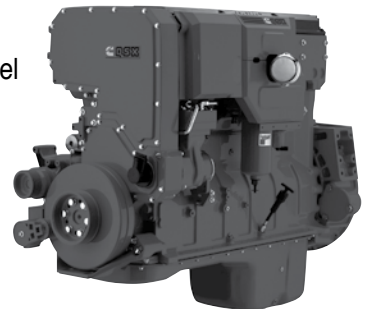

FUEL EFFICIENT MODE



The operator can select either "Power" or "Fuel Efficient" engine mode. Power mode provides added power for extreme applications. Fuel Efficient mode offers better fuel economy for standard applications.

HIGH EFFICIENCY HYDRAULIC SYSTEM

- Dry, reliable
- Cast iron, dirt tolerant, gear pumps
- Easy access to two-spool control valve
- Large oil reservoir keeps oil cooler

TRANSMISSION

- Automatic transmission selects optimum speed from second to fourth gear
- Single lever control
- Switch activates adjustable transmission declutch on the left brake pedal **1**
- Transmission declutch can be set by the operator to match operating conditions
- Downshift button speeds cycle times and reduces operator fatigue
- Helical gears reduce noise and vibration

AXLES/BRAKES

- Torque Proportioned Differentials improve traction in slippery conditions
- 29.5-25-22PR (L-3) tires standard
- Optional L-3 and L-5 bias and radial tires available in 26.5-25 and 29.5-25 sizes
- Autobrake, standard, protects the transmission from overspeeding and abrupt directional changes.
- 5-piece rims standard **2**
- Outboard-mounted, dual-circuit wet disc brakes **3**
- Easy maintenance
- High capacity
- Long life

LIFT ARMS/BUCKETS

- Dual Z-linkage
- High breakout force
- Optional high lift arms available
- 5.9 to 7.7 cu. yd. buckets
- Easy loading
- Excellent load retention
- Full assortment of edges and teeth
- Complete array of attachments available
- Bolt-on heel plates extend bucket life

ECONOMIC AND EFFICIENT SYSTEMS

- Hydraulic System, designed for energy efficiency with the steering flow to supplement the main circuit once steering demand is met. This allows for full utilization of the pump capacity for efficient operation in all conditions.
- Adjustable Boom Kickout can be set by the operator to attain proper dump height and return-to-dig height **4**
- Automatic 4-speed transmission, single grip
- Bucket leveler and boom kick-out standard

STRUCTURED TO LAST

- Redesigned buckets provide easy loading and excellent load retention
- Full assortment of edges and teeth
- Complete array of attachments available
- Massive center pins and bearings **5**
- Heavy box frame rear chassis **6**

5



4



3



2

1



6



THE COMFORT ZONE



ENJOY THE RIDE

- The cab provides excellent visibility in all directions **1**
- The front windshield is flat glass mounted in rubber gaskets that make windshield replacement fast and easy.
- Viscous mounting of the cab reduces vibration and noise
- Fully certified ROPS/FOPS cab meets all regulations
- Increased Leg Room
- Air Conditioning, standard
- Air Ride Seat, standard **2**
- Tilting and Telescopic Steering column
- Easy access to cab on both sides of machine
- Automotive-style roll-up side windows
- AM/FM CD Radio with AUX Input, standard.
- Increased personal storage
- Front and Rear window wipers and washers

1

TOTAL COMMAND. TOTAL CONTROL.

- MODM (Machine Operation Diagnostic Module) offers information to make the operation, maintenance and troubleshooting more efficient. With this information, operators, maintenance and technical personnel can quickly determine key operating data. **3**
- Downshift Button, located on the boom control **4**
- Adjustable Declutch allows the operator to select the location of the left brake pedal where the declutch engages. This allows the operator to easily adjust for various operating conditions.
- 12V outlet for operator to use 2-way radios and other plug-in devices **3**
- ELS — Efficient Loading System, increases rimpull power when digging while demanding less fuel. Increases productivity and fuel efficiency. A switch on the instrument control panel allows operator to activate from cab. **4**



ACCESSIBILITY, SERVICEABILITY, DURABILITY

- Sealed universal joints only require greasing at 12,000 hour intervals extending the life expectancy of the drive shaft
- Engine side covers open wide for optimum access
- Easy access to filters, drains and fittings
- MODM (Machine Operation Diagnostic Module) offers information to make the operation, maintenance and troubleshooting more efficient. With this information, operators, maintenance and technical personnel can quickly determine key operating data.
- Increased Transmission Capacity provides greater service life
- Outboard Wet Disc Brakes, sealed, provide high capacity braking and protection from contamination. The dual brake system separates the front and rear axles for added safety.
- Sealed Deutsch DT electrical connectors are used throughout the system to reduce corrosion and improve durability
- Automatic reversible cooling fan in conjunction with the wide fin radiator, both standard, aid in keeping debris from building in the radiator and cooling cores.
- New standard transmission sight gauge with larger filler tube eases transmission servicing.



OPTIONS

OPTIONAL EQUIPMENT

- JRB Quick Coupler and Attachments **1**
- Limited Slip Differentials provide additional traction for applications requiring extreme traction control. **2**
- K-Lever, stick steering **3**
- F-R Directional Switch allows the operator to select direction directly from the side console.
- Ride Control offers a smooth ride to improve load retention and increase travel speeds. **4**
- HID (High Intensity Discharge) lights are extremely bright lights with exceptionally long service life.
- Autolube
- Back-up Camera
- Transmission Lock-up Torque Converter

- K-Link, a management tool, provides on demand reports on machine location, hours, system sensors, engine performance, operating status, geo-fence break alerts and several customizable reports by phone, pager, or e-mail
- Single Lever Hydraulic Control increases operator efficiency

SPECIAL APPLICATION PACKAGES

- Agriculture
- Hot Slag
- Logging/Woodchip
- Waste/Refuse/Recycling

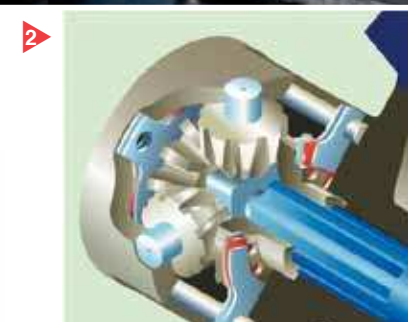
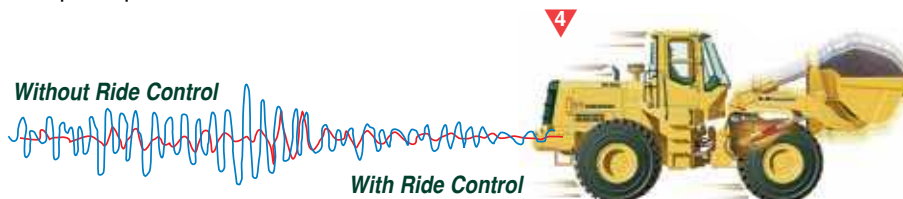

BUCKET DATA

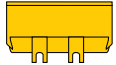
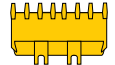
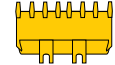
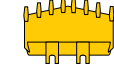
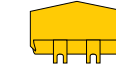
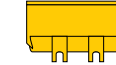
			Standard Boom					
			General Purpose		Rock Straight	Rock-V-Edge		Material Handling
			Straight Edge With Bolt-on Cutting Edge	Straight Edge With Teeth	Straight Edge With Teeth & Segments	Spade Nose With Teeth & Segments	Spade Nose Without Teeth	Straight Edge With Bolt-on Cutting Edge
								
Capacity	Heaped	yd ³ (m ³)	7.0 (5.4)	6.6 (5.0)	6.0 (4.6)	6.1 (4.7)	5.9 (4.5)	7.7 (5.9)
	Struck	yd ³ (m ³)	5.8 (4.4)	5.5 (4.2)	5.0 (3.8)	5.1 (3.9)	4.9 (3.7)	(6.7) (5.1)
Maximum dumping clearance		ft-in (mm)	10'6 ³ / ₁₆ " (3,220)	10'2 ¹ / ₄ " (3,105)	9'1 ¹⁵ / ₁₆ " (3,030)	9'6 ³ / ₁₆ " (2,900)	10'1 ⁷ / ₈ " (3,095)	10'3" (3,125)
Dumping reach (to front of bucket edge or tooth)		ft-in (mm)	4'5 ⁵ / ₃₂ " (1,350)	4'7 ⁷ / ₈ " (1,420)	4'10 ¹¹ / ₁₆ " (1,490)	5'3 ⁹ / ₁₆ " (1,615)	4'11 ⁵ / ₈ " (1,515)	4'8 ⁷ / ₈ " (1,445)
Bucket hinge pin height		ft-in (mm)	14'8 ³ / ₄ " (4,490)	14'8 ³ / ₄ " (4,490)	14'8 ³ / ₄ " (4,490)	14'8 ³ / ₄ " (4,490)	14'8 ³ / ₄ " (4,490)	14'8 ³ / ₄ " (4,490)
Digging depth		ft-in (mm)	3 ⁵ / ₃₂ " (80)	4 ⁵ / ₁₆ " (110)	4 ⁵ / ₁₆ " (110)	4 ⁵ / ₁₆ " (110)	2" (50)	3 ⁵ / ₃₂ " (80)
Breakout force		lb (kg)	55,120 (25,000)	59,525 (27,000)	52,030 (23,600)	45,190 (20,500)	47,400 (21,500)	50,040 (22,700)
Bucket tilt-back angle	at ground level		43°	43°	43°	43°	43°	43°
	at carry position		51°	51°	51°	51°	51°	51°
Overall	Length	ft-in (mm)	30'5 ³ / ₈ " (9,280)	30'10 ⁷ / ₈ " (9,420)	31'2 ³ / ₁₆ " (9,520)	31'9 ⁷ / ₈ " (9,700)	31'2" (9,500)	30'10 ¹ / ₂ " (9,410)
	Height	ft-in (mm)	12'4" (3,760)	12'4" (3,760)	12'4" (3,760)	12'4" (3,760)	12'4" (3,760)	12' 4" (3,760)
	Width (outside tire)	ft-in (mm)	10'6 ³ / ₄ " (3,220)	10'6 ³ / ₄ " (3,220)	10'6 ³ / ₄ " (3,220)	10'6 ³ / ₄ " (3,220)	10'6 ³ / ₄ " (3,220)	10'6 ³ / ₄ " (3,220)
	Width (outside bucket)	ft-in (mm)	11'3 ⁷ / ₈ " (3,450)	11'4 ¹ / ₂ " (3,465)	11'4 ¹ / ₂ " (3,465)	11'4 ¹ / ₂ " (3,465)	11'3 ⁷ / ₈ " (3,450)	11'3 ⁷ / ₈ " (3,450)
Wheel base		ft-in (mm)	11'9 ³ / ₄ " (3,600)	11'9 ³ / ₄ " (3,600)	11'9 ³ / ₄ " (3,600)	11'9 ³ / ₄ " (3,600)	11'9 ³ / ₄ " (3,600)	11'9 ³ / ₄ " (3,600)
Minimum turning radius	at outside bucket	ft-in (mm)	23'10 ¹ / ₂ " (7,275)	24'1/4" (7,320)	24'3 ³ / ₄ " (7,410)	24'3 ³ / ₄ " (7,410)	24'9 ¹ / ₁₆ " (7,330)	24'2 ³ / ₄ " (7,385)
	at center of outside tire	ft-in (mm)	20'2 ¹ / ₂ " (6,160)	20'2 ¹ / ₂ " (6,160)	20'2 ¹ / ₂ " (6,160)	20'2 ¹ / ₂ " (6,160)	20'2 ¹ / ₂ " (6,160)	20'2 ¹ / ₂ " (6,160)
Minimum ground clearance		ft-in (mm)	1'7 ¹¹ / ₁₆ " (500)	1'7 ¹¹ / ₁₆ " (500)	1'7 ¹¹ / ₁₆ " (500)	1'7 ¹¹ / ₁₆ " (500)	1'7 ¹¹ / ₁₆ " (500)	1'7 ¹¹ / ₁₆ " (500)
Full articulation angle		degree	40°	40°	40°	40°	40°	40°
Operating weight (with ROPS Cabin)		lb (kg)	68,170 (30,920)	67,790 (30,750)	67,220 (30,490)	67,500 (30,620)	66,540 (30,180)	68,370 (31,010)
Static Tipping Load (with ROPS Cabin)	Straight	lb (kg)	53,420 (24,230)	53,770 (24,390)	53,480 (24,260)	53,180 (24,120)	54,230 (24,600)	53,180 (24,120)
	Full turn	lb (kg)	43,940 (19,930)	44,220 (20,060)	43,980 (19,950)	43,740 (19,840)	44,620 (20,240)	43,740 (19,840)

The weight and load figure includes optional counterweight, AC, Enclosed ROPS Cab. 29.5x25-22PR (L-3) tires. Full fuel tank and operator.

Materials and specifications are subject to change without notice and without obligation on the part of the manufacturer. The specifications supplied, while believed to be completely reliable, are not to be taken as warranty for which we assume legal responsibility.

BUCKET DATA

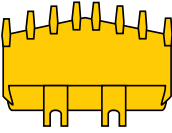
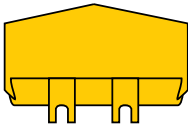
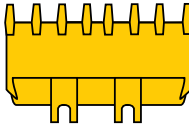
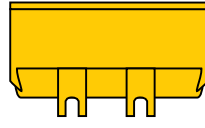
			High Lift Boom				
			Rock-V-Edge		Rock-Straight		General Purpose
			With Teeth	Without Teeth	With Teeth	With Bolt-on Cutting Edge	
							
Capacity	Heaped	yd ³ (m ³)	5.0 (3.8)	5.0 (3.8)	5.0 (3.8)	5.5 (4.2)	
	Struck	yd ³ (m ³)	4.2 (3.2)	4.2 (3.2)	4.2 (3.2)	4.7 (3.6)	
Maximum dumping clearance		ft-in (mm)	11'4 ¹ / ₄ " (3,460)	11'11 ¹¹ / ₁₆ " (3,650)	11'9" (3,580)	12'2 ¹ / ₁₆ " (3,710)	
Dumping reach (to front of bucket edge or tooth)		ft-in (mm)	4'11 ⁷ / ₈ " (1,520)	4'7 ⁷ / ₈ " (1,420)	4'7 ¹ / ₈ " (1,400)	4'4" (1,320)	
Bucket hinge pin height		ft-in (mm)	16' ¹⁵ / ₁₆ " (4,900)	16' ¹⁵ / ₁₆ " (4,900)	16' ¹⁵ / ₁₆ " (4,900)	16' ¹⁵ / ₁₆ " (4,900)	
Digging depth		ft-in (mm)	4 ⁵ / ₁₆ " (110)	2" (50)	4 ⁵ / ₁₆ " (110)	3 ⁵ / ₃₂ " (80)	
Breakout force		lb (kg)	63,230 (28,680)	63,230 (28,680)	65,260 (29,600)	60,160 (27,290)	
Bucket tilt-back angle	at ground level		43°	43°	43°	43°	
	at carry position		51°	51°	51°	51°	
Overall	Length	ft-in (mm)	32'6 ³ / ₁₆ " (9,910)	31'10 ⁵ / ₁₆ " (9,710)	31'11 ¹ / ₁₆ " (9,730)	31'5 ³ / ₁₆ " (9,580)	
	Height	ft-in (mm)	12'4" (3,760)	12'4" (3,760)	12'4" (3,760)	12'4" (3,760)	
	Width (outside tire)	ft-in (mm)	10'6 ³ / ₄ " (3,220)	10'6 ³ / ₄ " (3,220)	10'6 ³ / ₄ " (3,220)	10'6 ³ / ₄ " (3,220)	
	Width (outside bucket)	ft-in (mm)	11'4 ⁷ / ₁₆ " (3,465)	11'4 ⁷ / ₁₆ " (3,465)	11'4 ⁷ / ₁₆ " (3,465)	11'4 ⁷ / ₁₆ " (3,465)	
Wheel base		ft-in (mm)	11'9 ³ / ₄ " (3,600)	11'9 ³ / ₄ " (3,600)	11'9 ³ / ₄ " (3,600)	11'9 ³ / ₄ " (3,600)	
Minimum turning radius	at outside bucket	ft-in (mm)	24'9 ¹ / ₄ " (7,550)	24'6 ³ / ₃₂ " (7,470)	23'2 ³ / ₄ " (7,080)	24'7 ¹¹ / ₁₆ " (7,510)	
	at center of outside tire	ft-in (mm)	20'2 ¹ / ₂ " (6,160)	20'2 ¹ / ₂ " (6,160)	20'2 ¹ / ₂ " (6,160)	20'2 ¹ / ₂ " (6,160)	
Minimum ground clearance		ft-in (mm)	1'7 ¹¹ / ₁₆ " (500)	1'7 ¹¹ / ₁₆ " (500)	1'7 ¹¹ / ₁₆ " (500)	1'7 ¹¹ / ₁₆ " (500)	
Full articulation angle		degree	40°	40°	40°	40°	
Operating weight (with ROPS Cabin)		lb (kg)	68,780 (31,200)	68,300 (30,980)	68,520 (31,080)	68,120 (30,900)	
Static Tipping Load (with ROPS Cabin)	Straight	lb (kg)	44,910 (20,370)	45,390 (20,590)	45,170 (20,490)	45,570 (20,670)	
	Full turn	lb (kg)	36,950 (16,760)	37,350 (16,940)	37,170 (16,860)	37,480 (17,000)	

*The weight and load figure includes optional counterweight, AC, enclosed ROPS Cab., 29.5x25-22PR (L-3) tires, full fuel tank and operator. Measured in accordance with SAEJ732C &J742

OPERATING SPECIFICATIONS

WEIGHTS AND DIMENSIONS (SUPPLEMENTAL DATA)

		Operating Weight	Tipping Load			Overall Width (Outside Tire)	Tread	Vertical Dimensions	Overall Length
			Straight	Full Turn					
Remove ROPS Cab (for transport only)	lb (kg)	-1370 (-620)			in (mm)			-1'9 ¹¹ / ₁₆ " (-550)	
Remove Optional Counter Weight	lb (kg)	-900 (-410)	-2,250 (-1020)	-1,870 (-850)	in (mm)				
Air conditioner – Deletion	lb (kg)	-220 (-100)	-200 (-90)	-200 (-90)	in (mm)				
Belly Guard (Rear Frame)	lb (kg)	+510 (+230)	+860 (+390)	+750 (+340)	in (mm)				
Tires: 26.5-25-24PR (L-3)	lb (kg)	-930 (-420)	-710 (-320)	-620 (-280)	in (mm)	-3 ⁵ / ₈ " (-90)		-2" (-50)	+1 ⁵ / ₈ " (+40)
26.5-25-24PR (L-4)	lb (kg)	+1,260 (+570)	+950 (+430)	+840 (+380)	in (mm)	-2 ⁹ / ₈ " (-60)		-3 ³ / ₈ " (-10)	+3 ³ / ₈ " (+10)
26.5R25* (L-3)	lb (kg)	+120 (+55)	+90 (+40)	+80 (+35)	in (mm)	-3 ⁵ / ₈ " (-90)		-1 ¹ / ₂ " (-40)	+1 ³ / ₈ " (+35)
29.5-25-22PR (L-5)	lb (kg)	+2,380 (+1,080)	+1,810 (+820)	+1,609 (+730)	in (mm)	+3 ³ / ₈ " (+10)		+1 ⁵ / ₈ " (+40)	-1 ⁵ / ₈ " (-40)
29.5R25* (L-3)	lb (kg)	+1,320 (+600)	+990 (+450)	+880 (+400)	in (mm)			+5 ⁵ / ₈ " (+15)	-3 ³ / ₈ " (-10)
26.5-25-24PR (L-3) (75% CaCl ₂)	lb (kg)	+2,160 (+980)	+3,990 (+1,810)	+3,530 (+1600)	in (mm)	-3 ⁵ / ₈ " (-90)		-2" (-50)	+1 ⁵ / ₈ " (+40)
29.5-25-22PR (L-3) (75% CaCl ₂)	lb (kg)	+4,190 (+1,900)	+6,370 (+2,890)	+5,620 (+2,550)	in (mm)				

Base Tire 29.5-25-22PR (L-3)



OPERATING SPECIFICATIONS

Tread 8¹/₁₆" (2,440mm)
 Width (outside tire) 10⁶/₄" (3220mm)
 Width (outside bucket) 11³/₈" (3,450mm)
 Equipped with GSC bucket with bolt on cutting edge
 29.5-25-22PR (L-3) Tire and ROPS Cab

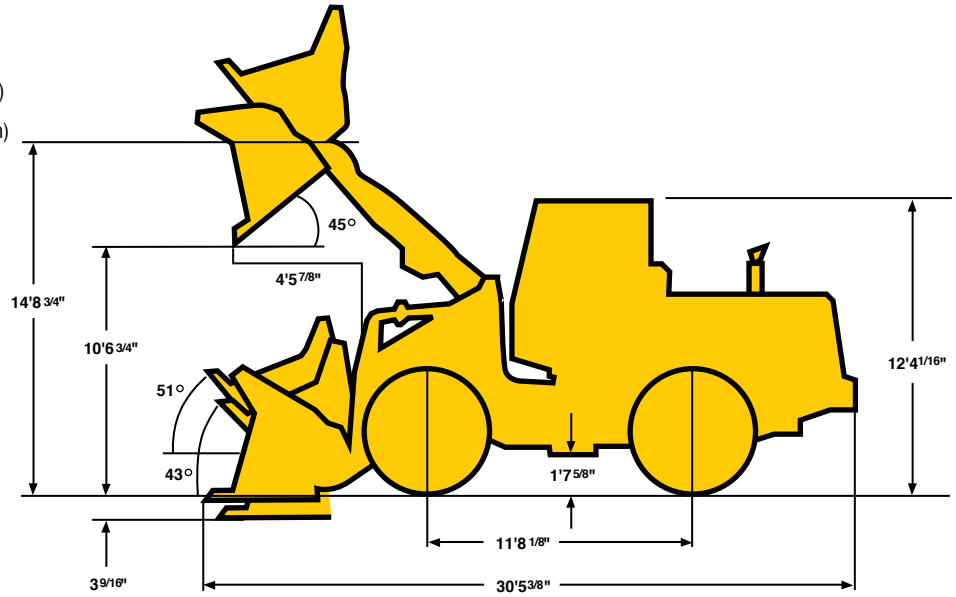

BUCKET SELECTION CHARTS

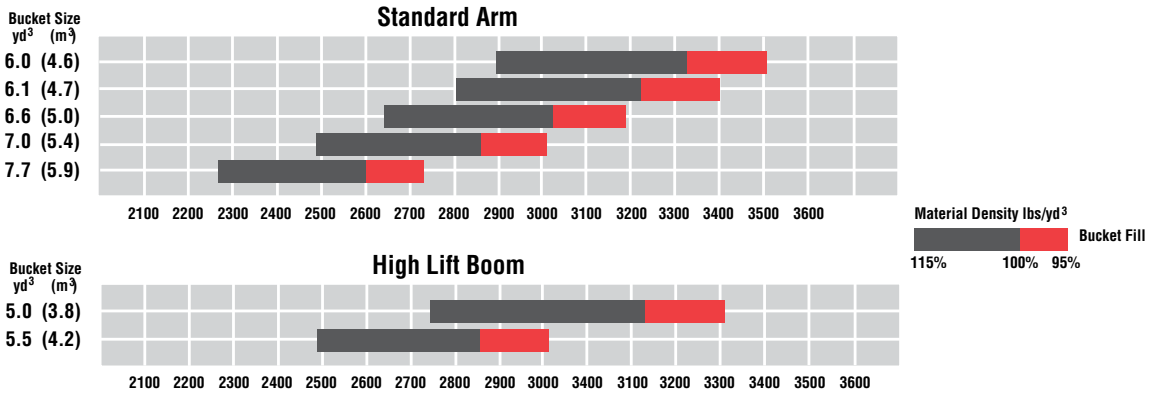

OPERATING SPECIFICATIONS

ENGINE	
Gross Power (SAE J1995)	390 HP/2200 RPM
Net Power (SAE J1349)	348HP/2000 RPM (263kw/2000RPM)
Net Peak Torque	1346 ft/lb @ 1400 RPM
Make/Model/Fuel Type	Cummins/QSX15/Diesel
Type	4-cycle, watercooled, in-line direct injection type with turbo charger and air-cooled intercooler
Number of cylinders	6
Bore and stroke	5.4" x 6.7" (136.9mm x 170.2mm)
Total displacement	917 in ³ (15,032 cm ³)
Alternator	AC24V – 1800W (75 amp)
Battery	12V – 200AH (1,300 CCA), 2 units

TORQUE CONVERTER AND TRANSMISSION		
Torque converter	3 elements, single stage, 1-phase	
Torque stall ratio	3.01:1	
Main clutches	Wet hydraulic, multi-disc type	
Cooling method	Forced circulation type	
Transmission	Full powershift, 4 forward, 3 reverse with automatic mode (2nd – 4th) with downshift switch for 2nd – 1st downshifting. Autobrake protects transmission from overspeeding	
Speeds	Forward	1st: 4.8 MPH (7.7km/hr) 2nd: 9.0 MPH (14.5km/hr) 3rd: 15.2 MPH (24.5 km/hr) 4th: 23.3 MPH (37.5 km/hr)
Speeds	Reverse	1st: 5.2 MPH (8.3 km/hr) 2nd: 9.7 MPH (15.6 km/hr) 3rd: 16.2 MPH (26.1 km/hr)

SYSTEMS CAPACITY		
LOCATION	Gallons	Liters
Engine (coolant)	26.4	(100)
Fuel tank (diesel fuel)	122.8	(465)
Engine oil (oil pan)	13.2	(50)
Front axle (gear oil)	26.4	(100)
Rear axle (gear oil)	26.4	(100)
Torque converter and transmission (engine oil)	17.2	(65)
Hydraulic system (including oil tank)	70	(265)

HYDRAULIC AND STEERING SYSTEM		
Steering type	Articulated frame steering	
Steering mechanism	Hydraulic power steering unit pilot operated type	
Lift (boom) cylinder	Two (2) double-acting piston type: 7.48" x 37.52" (190mm x 953mm)	
Tilt (bucket) cylinder	Two (2) double-acting piston type: 6.3" x 23.82" (160mm x 605mm)	
Steering cylinder	Two (2) double-acting piston type: 3.54" x 23.62" (90mm x 600mm)	
Steering oil pump	Gear type: 94.6 GPM @ 2000 RPM (358 LPM @ 2000 RPM)	
Main oil pump	Gear type: 50.2 GPM @ 2000 RPM (190 LPM @ 2000 RPM)	
Pilot oil pump	Gear type: 44.6 GPM @ 2000 RPM (169 LPM @ 2000 RPM)	
Relief valve set pressure	Loading	3000 psi (210 kg/cm ²)
	Steering	3000 psi (210 kg/cm ²)
HYDRAULIC CYCLE TIME*		
Lifting time (at full load)	6.1 sec.	
Lowering time (empty)	4.0 sec.	
Bucket dumping time	1.5 sec.	
TOTAL	11.6 sec.	

* Measured in accordance with SAE J732C

AXLE SYSTEM		
Drive system	4-wheel drive	
Front and rear axle	Full floating banjo type	
Tires	Standard	29.5 x 25-22PR (L-3)
	Optional	26.5 x 25-24PR (L-3) (L-4) (L-5) 26.5-R25
Reduction and differential gear	Spiral bevel/gear, 1 stage reduction torque proportioning	
Final reduction gear	Outboard mounted, internal planetary gear	
Oscillation angle	±12° (total 24°)	

BRAKE SYSTEM	
Service brakes	4 wheel, adjustment-free, wet multiple disc brake, controlled by full hydraulic system. Dual circuit
Parking/Emergency brake	Spring applied, oil pressure released. Enclosed wet disc type. Located in front axle driveline.

EQUIPMENT DATA

STANDARD EQUIPMENT

<p>Air Conditioner (R134 Refrigerant)</p> <p>Alarms (Audible): Auto Brake Brake Pressure Engine Oil Pressure Hydraulic Oil Level Parking Brake with T/M Engaged</p> <p>Alarms (Visual): Air Filter Battery Discharge Brake Pressure Central Warning Lamp Engine Coolant Level Engine Coolant Temp Engine Oil Pressure Engine Warning Hydraulic Oil Level Torque Converter Oil Temperature Transmission Control Warning</p> <p>Alternator (75 amp)</p> <p>AM/FM CD Radio with AUX Input</p> <p>Batteries: 12V-1,300 CCA (2 units)</p> <p>Boom Kickout (2-Position, Adjustable, In Cab)</p> <p>Brake Line Protection (Front)</p>	<p>Brake (Parking) Spring Applied, Oil Pressure Released, Enclosed Wet Disc Type</p> <p>Brakes (Service) Enclosed Wet Disc, Dual System Full Hydraulic System</p> <p>Bucket Control Lever Dual, Pilot Assisted</p> <p>Bucket Leveler</p> <p>Coat Hook</p> <p>Cold Start Aid</p> <p>Converter, 12V/15Amp dash outlet</p> <p>Cooling Fan, Automatic Reversible w/ manual override</p> <p>Cup Holder</p> <p>Downshift Button</p> <p>Drawbar</p> <p>ELS (Efficient Loading System)</p> <p>Engine Pre-Cleaner (Turbine Type)</p> <p>Fenders (Full Width Front w/ Mudflaps, Rear)</p>	<p>Gauges: Converter Oil Temperature Engine Coolant Temp Fuel Level Hour Meter Hydraulic Oil Level, Sight Tachometer</p> <p>Heater/Pressurizer</p> <p>Hoodsides (Hinged)</p> <p>Horn (Electric)</p> <p>Indicators: Auto Brake Engine Pre-Heater High Beam Parking Brake Transmission Declutch Transmission Shift Monitor Working Light</p> <p>Linkage (Dual Z-type, Sealed)</p> <p>Lights: 2 Headlights (Hi/Lo/Halogen) 4 Forward Working Lights 4 Rear Working Lights 2 Stop/Tail/Backup (LED)</p> <p>MODM (Machine Operation Diagnostic Module)</p> <p>Muffler</p> <p>Neutral Safety Start</p> <p>Operator's Manual Box</p>	<p>Radiator: Wide spaced Aluminum Fin Type</p> <p>Radiator Grille, Hinged</p> <p>Rear Under-Frame Cover</p> <p>Reverse Alarm</p> <p>ROPS Cab: Enclosed cab with sound suppression, front and rear wipers and washers, two rear view and two side mirrors, tinted glass, and sliding side windows</p> <p>Safety Articulation Locking Bar</p> <p>Seat, Air Ride</p> <p>Seat Belt, Retractable, 3" wide</p> <p>Shift Control Unit for Automatic Shift</p> <p>Steering Wheel, Telescoping and Tilt</p> <p>Torque Proportioning Differentials</p> <p>Transmission Declutch Select/Adjustment Switch</p> <p>Vandalism Protection</p> <p>Wrist Rest, Adjustable</p>
--	--	---	--

OPTIONAL EQUIPMENT

<p>AutoLube</p> <p>Back-up Camera</p> <p>Belly Guard, Hinged Transmission</p> <p>Bolt-On Cutting Edge Segments</p> <p>Bucket Teeth</p> <p>Counterweight, Bucket</p>	<p>Cushion Dump Valve</p> <p>Emergency Steering</p> <p>Fenders, Extra-Wide, Front & Rear (hinged)</p> <p>F-R Direction Switch</p> <p>HID Lighting (High Intensity Discharge)</p> <p>High Lift Arm</p>	<p>Hydraulic System, 3-Spool Valve</p> <p>K-Lever Steering</p> <p>K-Link</p> <p>Limited Slip Differentials</p> <p>Lock-up Torque Converter</p> <p>Multi Function Grip</p>	<p>Quick Coupler and Attachments</p> <p>Ride Control</p> <p>Single Lever Hydraulic Control</p> <p>Turn Signal With Four-Way Flasher</p>
---	---	---	---

KAWASAKI KEEPS IT SIMPLE.



Since 1962, Kawasaki has been listening to and learning from customers and dealers in the field. As a result, Kawasaki wheel loaders continue to evolve, with a constant focus on one thing — producing the most durable, most efficient, most dependable machines possible.

EASY TO OPERATE.

In a world of increasing demands, tighter deadlines, shrinking budgets and complicated contracts, better efficiency and greater productivity are a must. Innovative high-tech features on all Kawasaki wheel loaders allow the operator to adapt to the environment and the application right from the cab.

EASY TO MAINTAIN.

Diagnostic and operational modules monitor fluids and filters, and constantly provide information on everything from engine and transmission codes to location, hours, alarm sensors and machine performance data.

EASY TO DO BUSINESS WITH.

No run-arounds. No layers and layers of management. No distractions from competing product lines. Wheel loaders are our only business. Got a question? We'll get you an answer. Need a part? It's on its way. Quickly. Kawasaki offers flexible warranty programs, a state-of-the-art parts distribution system, an in-house rebuild center, and an experienced, knowledgeable support staff, focused on serving you.

The independent dealers that represent and support Kawasaki loaders are experts in their markets and are dedicated to providing you with the best service available.

Together, we are committed to making your investment in a Kawasaki loader a sound business decision that will pay dividends for years to come.

KAWASAKI. ONE FOCUS. COMPLETE SOLUTIONS.



KCMA Corporation

2140 Barrett Park Drive • Suite 101
Kennesaw, Georgia 30144
www.kawasakiloaders.com

Tel: 770-499-7000
Fax: 770-421-6842