

KOBELCO®

140SR ACERA® SHORT RADIUS EXCAVATOR



Operating Weight
32,040 lbs (14,735 kg)

Net Horsepower
94 hp @ 2,000 rpm
(70.1 kW @ 2,000 rpm)

Max Digging Depth
19' 7" (5.98 m)

Bucket Capacity
.30 to .88 cu yd
(.229 to .672 m³)

Bucket Breakout Force
(SAE) 19,000 lbf (84.5 kN)
(ISO) 21,357 lbf (95.0 kN)

Courtesy of Machine.Market

140SR ACERA

THE ULTIMATE DESIGN FOR MULTI-TASKING!

The **Kobelco 140SR ACERA** is the excavator of choice, especially for urban construction sites that offer limited access and require low system noise and exhaust emissions. The 140SR offers maximum versatility with deep dig depth, reliable breakout power, leading drawbar pull force, dozing & backfilling capability and optimized personal comfort.

Kobelco's exclusive **INDR® (Integrated Noise & Dust Reduction)** system reduces operating noise and emissions while maximizing power and systems cooling.

Proven **MITSUBISHI** Engine Performance

The 140SR ACERA delivers leading performance with proven Mitsubishi engine technology. Cranking out 94hp and 508 lb-ft of torque, the 140SR has power to out-dig, out-cycle, out-dump and out-doze the competition.

- Tier III certified 259 cu. in., 4-cylinder, turbo-charged diesel engine
- 94 Net (SAE J1349) engine horsepower @ 2,000 rpm
- 508 lb-ft of engine torque @ 1,600 rpm
- 9% more drawbar pull force than prior 135SR
- 9% increase in hydraulic flow

Heavy-Duty Components

- Long X-frame delivers enhanced stability and superior balance
- Durable Boom and Arm (with rock guard) are standard
- Rollers, sprockets and travel motors are sealed for long life
- Robust lift cylinders ensure maximum rated capacity
- Pumps, valves and piping are optimized for maximum efficiency
- Flanged Steel bucket bushings deliver long life

Innovative/integrated Design

- **INDR** efficiently manages incoming and outgoing air to attain low noise levels, superior system cooling and maximum particulate filtration
- Short Radius platform is ideal for working in tight spaces
- Ergonomically designed cab offers personalized comfort settings
- Integrated counter weight design blends into the overall upper-body structure, providing balance, beauty and minimal tail-swing overhang





A separate swing-out door eliminates the need to remove the pre-screen when checking only the two-stage engine air filter.

Battery access is also provided.

Long Life pre-filter screen can be easily removed for routine cleaning and reinstallation.

Tier III certified 259 cu. in., 4-cylinder, turbo-charged Mitsubishi diesel engine cranks out 94 hp Net (SAE).



FUTURE NOISE REDUCTION TECHNOLOGY IS HERE!

Kobelco's **Integrated Noise & Dust Reduction** system (**INDR**) is a unique design that provides:

- Superior filtration that extends engine air filter life
- Excellent engine and hydraulic system cooling
- Integrated counter weight design

INDR X-Ray View below demonstrates this activity

Advanced air-flow technology draws cool outside air (**Blue** arrows) through vents that are integrated into the overall excavator structure.

A pre-filter screen traps particulates larger than 1mm before the incoming air reaches the two-stage engine air filter. High volume air proceeds to cool the radiator, hydraulic oil cooler, turbo intercooler and entire engine compartment before exhausting through the upper rear vents of the excavator (**Green** arrows).

Engine exhaust emissions exit through the muffler tail pipe away from the excavator.

The **INDR** system is designed to provide premium air filtration and excellent engine cooling while reducing noise emissions by up to 5 dBA, making the 140SR as quiet as many compact excavators.

INDR makes the 140SR ACERA the excavator of choice for working in space-restricted environments that require minimal noise disruption.

INDR X-RAY VIEW

INDR cleans and quiets incoming air, reduces exhaust noise and delivers optimum cooling.

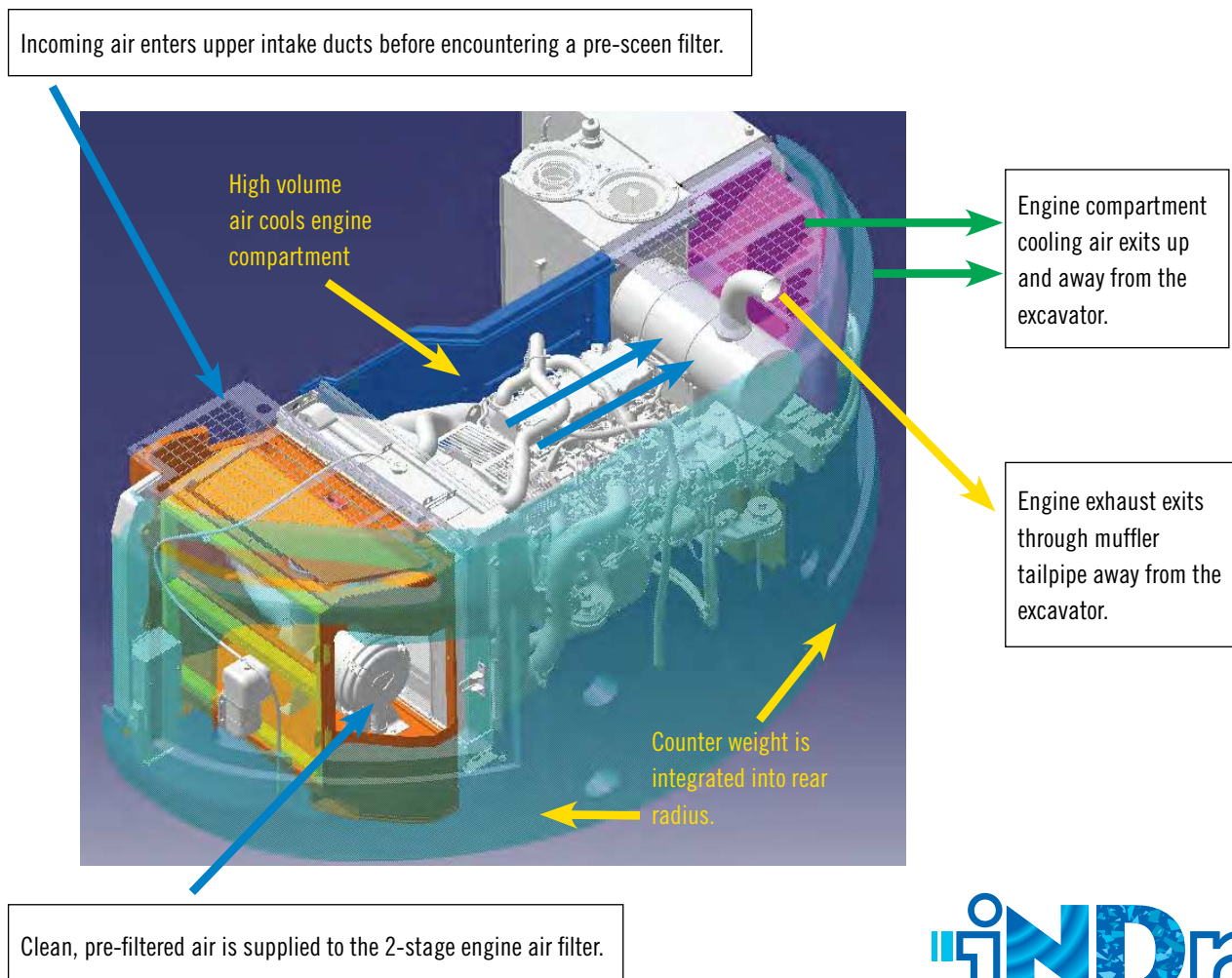



The INDR system is completely integrated into the rear radius of the 140SR. This optimizes functionality while providing balance and beauty.

The enclosed counter weight structure also provides protection and sound reduction for the tandem in-line hydraulic pumps.

Hydraulic hoses, pilot filter and engine mounts are also accessible.



PERSONALIZED LEVEL OF COMFORT

At Kobelco, we put you, the operator – first. We know you can't perform at your best if you're not comfortable. That's why Kobelco has gone to the extremes to ensure that our cabs deliver maximum personal comfort, easy to monitor system performance and a clear view of the job site.

A Cab Designed Around You

- Full-size cab provides 32% wider entry/exit room than prior model
- 7-way adjustable seat lets you personalize the level of comfort
- Key controls are located on the right-side console for easy access
- Programmable climate-control system ensures year-round comfort
- AM/FM stereo with dual speakers lets you enjoy your favorite programs
- 24 volt and 12 volt converters for charging cell phones and accessories
- Storage area is located behind operator's seat

Clear Job-Site Visibility

- Kobelco cabs provide clear visibility with minimal obstructions
- Large tinted glass panels provide an excellent view of the work station
- Operator is positioned for maximum visibility of all functions and controls
- Moveable front, top and side glass panels provide cross-flow ventilation

Easy-to-Read Instruments

- New Monitor includes work mode selector switch, fuel and temperature gauges, and an orange backlit multi-display with large sun shade
- Self-diagnostics with fault code memory makes it easy to monitor and adjust system pressures, engine speed, travel speed and other functions
- Warning screens and audible alarms alert you to temperature and pressure status
- Establish and review service interval reminders for engine oil, hydraulic oil, fuel and filters

Personal Climate Control

- High efficiency/high output air conditioning & heating system
- Program a temperature between 61 and 91 degrees F (18 to 32 C) for year-round convenience and comfort
- Four fan speeds and LCD display let you monitor your environment
- Redesigned vents circulate air around the operator's compartment for exceptional air flow dynamics



The Power Mode System provides four power modes to match your work operations. The monitor features a large sunshade and orange back-lit screen for easy daytime viewing.

A personal climate control console includes an LCD display and controls for the high-output air conditioning and heating system and the four-speed fan.

Just program a temperature between 61 and 91 degrees F (18 to 32 C) for optimum comfort any time of the year.



ACERA



Spacious dimensions, thoughtful placement of key operating controls and an unrivaled view make the Kobelco cab a comfortable and productive place to work.

The durable, cushioned operator seat adjusts seven ways to maximize operator comfort.



140SR ACERA

DEPENDABLE POWER & CONTROL

The 140SR ACERA hydraulic compartment offers easy ground-level access to the extremely quiet, tandem in-line hydraulic pumps. Our **Intelligent Total Control System (ITCS)** efficiently maximizes both engine and hydraulic performance to give you ground breaking power and smooth, progressive operational control.

Intelligent Total Control System (ITCS)

ITCS integrates communication and execution between the engine, hydraulics and electronics for superior operational control. ITCS:

- Recognizes your moves and assists by providing progressive power, where and when it's needed, so you stay in control.
- Provides smooth, even movement required for fine grading and leveling
- Auto-Accel smoothly increases engine rpms and hydraulic flow in direct proportion to the operator's movement of the control levers. This results in even, deliberate acceleration for precise applications.
- Auto-Decel reduces engine rpms after 4 seconds of operator inactivity, extending engine life and reducing fuel cost. (Time-delay is adjustable).

Power Mode Selection

The 140SR ACERA provides four work modes:

- **H Mode** Heavy-duty excavation work, gives priority to the workload at high speed (default mode)
- **S Mode** Standard digging and loading work, provides fuel savings
- **B Mode** Breaker work (1-way hydraulic flow)
- **A Mode** Demolition work with crusher/nibbler-breaker (2-way/2 pump flow)

Changing modes is fast and easily viewable on the Orange, back-lit readout display

Auto Warm-up System

Kobelco's "hands-off" engine and hydraulic warm-up system automatically warms the hydraulic circuit to an optimum 126 degrees (F) and kicks-in whenever ambient temperatures drop below 50 degrees (F). This feature maximizes system efficiency so you can be more productive.



Swing-out front door panel provides access to valve assembly and hydraulic lines.

2-Stage engine air filter and radiator systems are accessible after removal of pre-filter screen.



Anti-slip step pads and support rail provide secure access to the upper structure.

Dual 80 Amp Hr batteries are easy to access and protected by a heavy-duty rubber cover.

140SR ACERA

Smooth, Powerful Hydraulics

Kobelco performance features are unmatched by the competition.

- High performance tandem in-line hydraulic pumps are quiet and efficient, lowering overall operating costs
- Independent Travel circuit provides dedicated flow for excavator travel
- Swing priority dedicates power for trenching operations
- Boom and arm holding valves minimize drift for accurate positioning
- Standard high-flow valve can be switched between one-pump flow to two-pump flow from inside the cab
- Hydraulic flow has been increased by 9% to improve overall performance

Easy Maintenance & Servicing

The 140SR ACERA provides ground-level access to:

- INDR pre-filter for cleaning with air or water
- Side-by-side radiator, oil cooler and intercooler
- Hydraulic pump, tank, valves, hoses and filters
- Batteries, air filter, back-up alarm and other connections

Designed with Attachments in Mind

Kobelco doesn't just design excavators; we design excavators for use with attachments on the jobsite.

- High-output hydraulic system is adjustable from inside the cab
- Standard one or two-way auxiliary valve makes it easy to install piping and controls for auxiliary hydraulics
- Two auxiliary hydraulic modes permit switching between one-way and two-way hydraulic flow without leaving the cab
- An optional independent flow 'extra' circuit, powered by rotary gear pump, provides flow for multi-function attachments that include thumbs or twist buckets

Feel the passion we've built into the new Kobelco 140SR ACERA excavator. For productivity, comfort and fine control, see your Kobelco dealer today, or use our dealer locator at www.kobelcoamerica.com to find the dealer nearest you.



140SR DIMENSIONS, WEIGHTS & BUCKET SELECTION CHART

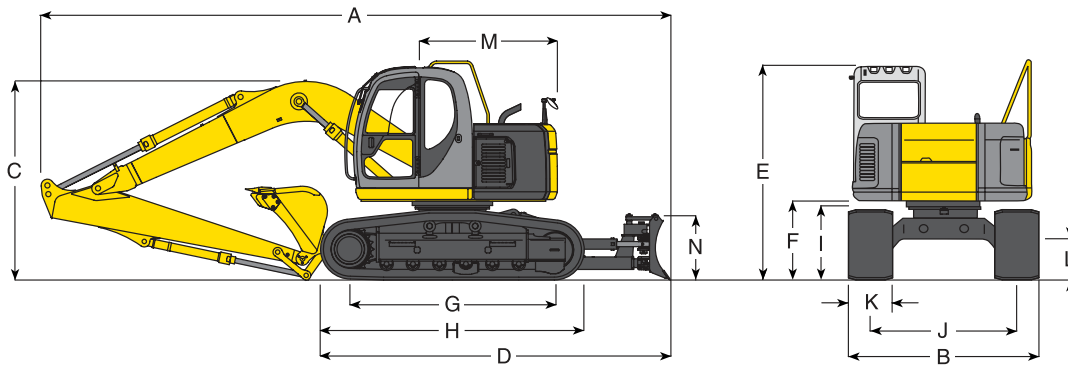

DIMENSIONS

	Standard Arm		Optional Arm	
ARM LENGTH ft (m)	9' 4"	(2.84 m)	7' 10"	(2.38 m)
BOOM LENGTH	15' 5"	(4.72 m)	15' 5"	(4.72 m)
A Overall length	24' 7"	(7.5)	24' 2"	(7.37)
B Overall width (with 600 mm shoe)	8' 6"	(2.59)	8' 6"	(2.59)
C Overall height (to top of boom)	10' 1"	(3.07)	9' 4"	(2.84)
D Basic machine length	14' 0"	(4.27)	14' 0"	(4.27)
E Overall height (to top of cab)*	9' 3"	(2.82)	9' 3"	(2.82)
F Ground clearance of rear end*	2' 10"	(0.855)	2' 10"	(0.855)
G Center distance of tumbler	10' 0"	(3.04)	10' 0"	(3.04)
H Overall length of crawler	12' 4"	(3.75)	12' 4"	(3.75)
I Crawler height at tumbler center*	2' 7"	(0.775)	2' 7"	(0.775)
J Track gauge	6' 6"	(1.99)	6' 6"	(1.99)
K Width of crawler shoe	2' 0"	(0.60)	2' 0"	(0.60)
L Ground clearance of undercarriage*	1' 5"	(0.435)	1' 5"	(0.435)
M Tail swing radius	4' 10"	(1.49)	4' 10"	(1.49)
N Height of blade	22"	(0.56)	22"	(0.56)

* Excludes height of grouser bar

WEIGHTS

140SR with 9'4" (2.84 m) std. HD arm, and bucket weighing 740 lbs (335 kg)

Operating weight w/bucket	lb (kg)	32,040 (14,735)
Machine weight	in (mm)	31,300 (14,400)
Ground pressure	psi (kPa)	5.08 (35)
Standard counter weight	lb (kg)	7,500 (3,400)

HYDRAULIC SYSTEM

Pump	Tandem inline variable displacement 2 VP + 1 FG		
Max. discharge flow	US gal/min (l/min)	2 x 34.3	(2 x 130)
Auxiliary pump output	US gal/min (l/min)	1 x 5.3	(1 x 20)
Operating pressure:			
Implement	psi (MPa)	4,970	(34.3)
Travel	psi (MPa)	4,970	(34.3)
Swing	psi (MPa)	4,060	(28.0)
Pilot control circuit	psi (MPa)	725	(5.0)
Control valves (directional)	8-spool valves		

BUCKET SELECTION CHART

Bucket Duty	Capacity (SAE)		Width		Bucket		Arm ft-in (m)
	Cubic Yard (m³)		Inches (m)		Weight lb (kg)		9'4" (2.84)
General	.30	(.229)	18	(.457)	650	(296)	H
	.44	(.336)	24	(.609)	720	(327)	H
	.58	(.443)	30	(.762)	835	(379)	M
	.73	(.558)	36	(.914)	905	(411)	L
	.88	(.672)	42	(1.066)	1,015	(460)	L
Heavy Duty	.30	(.299)	18	(.457)	705	(320)	H
	.44	(.336)	24	(.609)	780	(354)	H
	.58	(.443)	30	(.762)	900	(408)	M
	.73	(.558)	36	(.914)	975	(442)	L
	.88	(.672)	42	(1.066)	1,090	(494)	X

H - Used with material weight up to 3,000 lbs/cu yd (1,780 kg/m³)
M - Used with material weight up to 2,500 lbs/cu yd (1,483 kg/m³)

L - Used with material weight up to 2,000 lbs/cu yd (1,186 kg/m³)
X - Not recommended

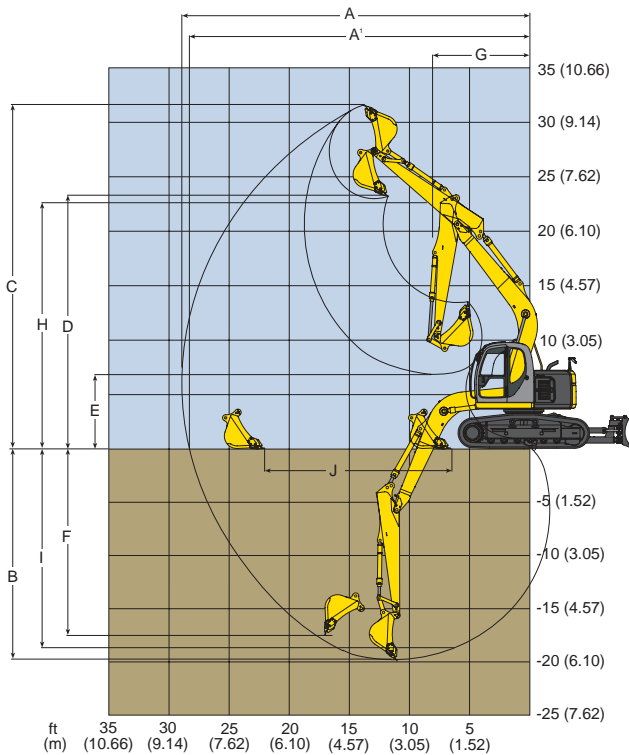

This chart is a graphic representation of the working ranges for the 140SR equipped with a 9' 4" (2.84 m) arm.

PERFORMANCE SUMMARY

Travel speed (turtle)	mph (km/h)	2.1 (3.40)
Travel speed (rabbit)	mph (km/h)	3.5 (5.60)
Swing speed	rpm	11.5
Gradeability	degrees (%)	35 (70)
Drawbar pulling force	lbs (kN)	31,000 (138)
Swing Torque	ft-lbs (kN•m)	27,175 (38)
Bucket capacity range (SAE heaped)	cu yd (m ³)	0.5 (0.38)

ENGINE

Make and Model	Mitsubishi	D04FR-74kW
Type	Water-cooled, 4-cylinder, 4-cycle direct injection diesel engine with intercooler turbo-charger.	
Displacement	cu in (l)	259 (4.25)
Bore	in (mm)	4.02 (102)
Stroke	in (mm)	5.12 (130)
Fuel tank capacity	gal (l)	52.8 (200)
Electrical system	volts (amperes)	24 (30)
Horsepower SAE NET	hp (kW) @ rpm	94 @ 2,000 (70.1 @ 2,000)
Max. torque	lbf-ft (kN•m)	508 @ 1,600 (375 @ 1,600)

WORKING RANGES

ARM	ft-in (m)	Standard	Optional
		9' 4" (2.84)	7' 10" (2.38)
A Max digging reach		28' 10" (8.78)	27' 4" (8.34)
A' Max digging reach at ground level		28' 4" (8.64)	26' 10" (8.19)
B Max digging depth		19' 7" (5.98)	18' 1" (5.52)
C Max digging height		32' 4" (9.55)	30' 2" (9.19)
D Max dumping clearance		23' 4" (7.11)	22' 1" (6.74)
E Min dumping clearance		7' 3" (2.22)	8' 6" (2.58)
F Max vertical wall digging depth		17' 6" (5.35)	16' 1" (4.89)
G Min front swing radius		7' 10" (2.40)	6' 7" (2.00)
H Height at min front swing radius		22' 6" (6.85)	22' 5" (6.83)
I Digging depth at 8' (2.4 m) level bottom		18' 10" (5.74)	17' 4" (5.29)
J Horiz digging stroke at ground level		15' 6" (4.72)	13' 10" (4.21)

Measurements shown are for machines equipped with the 0.7 cu. yd. (0.5 m³) bucket.

BREAKOUT FORCES

ARM	ft-in (m)	Standard	Optional
		9' 4" (2.84)	7' 10" (2.38)
Arm breakout force	SAE lbs (kN)	12,634 (56.2)	14,006 (62.3)
Arm breakout force	ISO lbs (kN)	13,129 (58.4)	14,478 (64.4)
Bucket breakout force	SAE lbf (kN)	19,000 (84.5)	18,299 (81.4)
Bucket breakout force	ISO lbf (kN)	21,357 (95.0)	20,255 (90.1)

REFILL CAPACITIES

Fuel tank capacity	gal (l)	52.8 (200)
Hydraulic oil reservoir	gal (l)	26 (98.5)
Hydraulic system including oil reservoir	gal (l)	40 (140)
Cooling system	gal (l)	3.7 (14)
Lubrication: engine oil	gal (l)	4.89 (18.5)

UNDERCARRIAGE

Track overall length	ft-in (m)	12' 4" (3.75)
Track overall width w/std. shoe	ft-in (m)	8' 6" (2.59)
Standard track shoe	in (mm)	23.6 (600)
Ground Clearance-Undercarriage	in (mm)	1' 5" (435)

SHIPPING DIMENSIONS

Overall Excavator Height	ft-in (m)	10' 1" (3.07)
Width w/Std. Shoe	ft-in (m)	8' 6" (2.59)
Length	ft-in (m)	24' 7" (7.5)



140SR LIFT CAPACITIES — 9' 4" Standard Arm

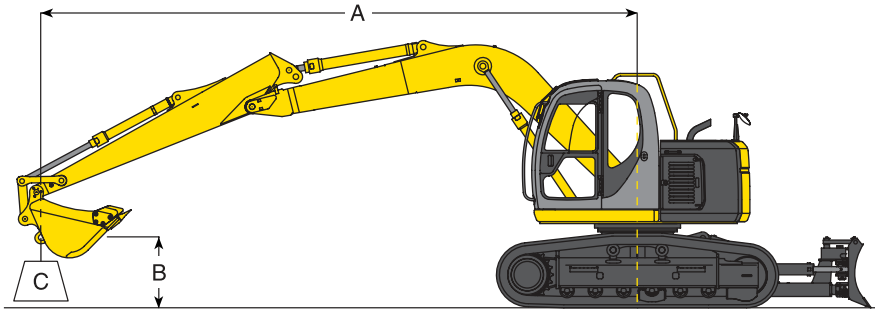

- A** Reach of swing centerline to bucket hook
- B** Bucket hook height above/below ground
- C** Lifting capacities in pounds and kilograms
 - Max discharge pressure: 4,970 psi (349 kg/cm²)
 - Track shoe: 23.6" (600 mm) Triple grouser
 - Boom: 15' 5" (4.72 m)
 - Bucket weight: 740 lbs. (335 kg)

LIFTING CAPACITY — 23.6" (600 mm) triple grouser shoe, with dozer. Based on machine equipped with — Arm: 9'4" (2.84 m)
 Bucket: 0.5 yd³ (0.38 m³) Bucket Weight: (SAE Heaped) 740 lbs. (335 kg) Counter Weight: 8,790 lbs. (3,988 kg)

STANDARD EQUIPMENT - ARM 1 - ADD-ON COUNTER WEIGHT

A	LIFT POINT RADIUS										AT MAX. REACH				
	B	C	5' (1.5 m)		10' (3.0 m)		15' (4.6 m)		20' (6.1 m)		25' (7.6 m)		RADIUS		
			Icon 1	Icon 2	Icon 1	Icon 2	Icon 1	Icon 2	Icon 1	Icon 2	Icon 1	Icon 2			
25' (7.6 m)	lb												*3,380	*3,380	14' 10"
	kg												*1,530	*1,530	(4.52 m)
20' (6.1 m)	lb					*5,690	*5,690	*2,930	*2,930				*2,770	*2,770	20' 1"
	kg					*2,580	*2,580	*1,320	*1,320				*1,250	*1,250	(6.12 m)
15' (4.6 m)	lb					*6,250	*6,250	*5,880	4,710				*2,600	*2,600	23' 0"
	kg					*2,830	*2,830	*2,660	2,130				*1,170	*1,170	(7.03 m)
10' (3.0 m)	lb			*10,460	*10,460	*7,850	7,320	*6,650	4,490				*2,630	*2,630	24' 8"
	kg			*4,740	*4,740	*3,560	3,320	*3,010	2,030				*1,190	*1,190	(7.52 m)
5' (1.5 m)	lb			*15,870	12,490	*9,850	6,660	7,150	4,200	*3,320	2,830		*2,840	2,790	25' 2"
	kg			*7,190	5,660	*4,470	3,020	3,240	1,900	*1,500	1,280		*1,280	1,260	(7.67 m)
Ground Level	lb			*17,070	11,420	10,860	6,150	6,880	3,950				*3,280	2,800	24' 7"
	kg			*7,740	5,170	4,920	2,780	3,120	1,790				*1,480	1,270	(7.51 m)
-5' (-1.5 m)	lb	*10,150	*10,150	*17,890	11,160	10,590	5,900	6,730	3,820				*4,130	3,090	23' 0"
	kg	*4,600	*4,600	*8,110	5,060	4,800	2,670	3,050	1,730				*1,870	1,400	(7.01 m)
-10' (-3.0 m)	lb	*15,830	*15,830	*15,360	11,310	*10,190	5,920						*6,120	3,900	19' 11"
	kg	*7,180	*7,180	*6,960	5,120	*4,620	2,680						*2,770	1,760	(6.08 m)
-15' (-4.6 m)	lb			*9,940	*9,940								*6,270	*6,270	14' 7"
	kg			*4,510	*4,510								*2,840	*2,840	(4.45 m)

LIFTING CAPACITY — 23.6" (600 mm) triple grouser shoe, with dozer. Based on machine equipped with — Arm: 9'4" (2.84 m)
 Bucket: 0.5 yd³ (0.38 m³) Bucket Weight: (SAE Heaped) 740 lbs. (335 kg) Counter Weight: 7,500 lbs. (3,400 kg)









STANDARD EQUIPMENT - ARM 1 - STD. COUNTER WEIGHT

A	LIFT POINT RADIUS										AT MAX. REACH				
	B	C	5' (1.5 m)		10' (3.0 m)		15' (4.6 m)		20' (6.1 m)		25' (7.6 m)		RADIUS		
			Icon 1	Icon 2	Icon 1	Icon 2	Icon 1	Icon 2	Icon 1	Icon 2	Icon 1	Icon 2			
25' (7.6 m)	lb												*3,380	*3,380	14' 10"
	kg												*1,530	*1,530	(4.52 m)
20' (6.1 m)	lb					*5,690	*5,690	*2,930	*2,930				*2,770	*2,770	20' 1"
	kg					*2,580	*2,580	*1,320	*1,320				*1,250	*1,250	(6.12 m)
15' (4.6 m)	lb					*6,250	*6,250	*5,880	4,210				*2,600	*2,600	23' 0"
	kg					*2,830	*2,830	*2,660	1,910				*1,170	*1,170	(7.03 m)
10' (3.0 m)	lb			*10,460	*10,460	*7,850	6,610	*6,650	3,990				*2,630	*2,620	24' 8"
	kg			*4,740	*4,740	*3,560	2,990	*3,010	1,810				*1,190	1,180	(7.52 m)
5' (1.5 m)	lb			*15,870	11,230	*9,850	5,950	6,510	3,710	*3,320	2,450		*2,840	2,410	25' 2"
	kg			*7,190	5,090	*4,470	2,700	2,950	1,680	*1,500	1,110		*1,280	1,090	(7.67 m)
Ground Level	lb			*17,070	10,150	9,900	5,430	6,230	3,460				*3,280	2,410	24' 7"
	kg			*7,740	4,600	4,490	2,460	2,820	1,560				*1,480	1,090	(7.51 m)
-5' (-1.5 m)	lb	*10,150	*10,150	*17,890	9,900	9,620	5,190	6,090	3,320				*4,130	2,670	23' 0"
	kg	*4,600	*4,600	*8,110	4,490	4,360	2,350	2,760	1,500				*1,870	1,210	(7.01 m)
-10' (-3.0 m)	lb	*15,830	*15,830	*15,360	10,040	9,640	5,210						*6,120	3,400	19' 11"
	kg	*7,180	*7,180	*6,960	4,550	4,370	2,360						*2,770	1,540	(6.08 m)
-15' (-4.6 m)	lb			*9,940	*9,940								*6,270	5,790	14' 7"
	kg			*4,510	*4,510								*2,840	2,620	(4.45 m)

140SR LIFT CAPACITIES — 7' 10" Optional Arm









LIFTING CAPACITY — 23.6" (600 mm) triple grouser shoe, with dozer. Based on machine equipped with — Arm: 7'10" (2.38 m)
 Bucket: 0.7 yd³ (0.5 m³) Bucket Weight: (SAE Heaped) 740 lbs. (335 kg) Counter Weight: 8,790 lbs. (3,988 kg)

OPTIONAL EQUIPMENT - ARM 2 - ADD-ON COUNTER WEIGHT

B	A C	LIFT POINT RADIUS								AT MAX. REACH		
		5' (1.5 m)		10' (3.0 m)		15' (4.6 m)		20' (6.1 m)		RADIUS		
												
25' (7.6 m)	lb kg									*3,570 *1,610	*3,570 *1,610	12' 2" (3.70 m)
20' (6.1 m)	lb kg					*6,310 *2,860	*6,310 *2,860			*2,810 *1,270	*2,810 *1,270	18' 2" (5.55 m)
15' (4.6 m)	lb kg					*7,080 *3,210	*7,080 *3,210	*5,290 *2,400	4,630 2,100	*2,640 *1,190	*2,640 *1,190	21' 5" (6.55 m)
10' (3.0 m)	lb kg			*12,270 *5,560	*12,270 *5,560	*8,650 *3,920	7,200 3,260	*7,150 *3,240	4,450 2,020	*2,700 *1,220	*2,700 *1,220	23' 2" (7.07 m)
5' (1.5 m)	lb kg			*17,280 *7,840	12,200 5,530	*10,500 *4,760	6,600 2,990	7,140 3,240	4,200 1,900	*2,960 *1,340	*2,960 *1,340	23' 8" (7.23 m)
Ground Level	lb kg			*16,370 *7,420	11,450 5,190	10,890 4,930	6,180 2,800	6,920 3,130	4,000 1,810	*3,500 *1,580	3,160 1,430	23' 2" (7.06 m)
-5' (-1.5 m)	lb kg	*11,750 *5,320	*11,750 *5,320	*17,400 *7,890	11,370 5,150	10,700 4,850	6,020 2,730	6,830 3,100	3,920 1,770	*4,620 *2,090	3,550 1,610	21' 4" (6.52 m)
-10' (-3.0 m)	lb kg	*18,220 *8,260	*18,220 *8,260	*14,190 *6,430	11,610 5,260	*9,560 *4,330	6,110 2,770			*7,230 *3,270	4,660 2,110	18' 0" (5.51 m)

LIFTING CAPACITY — 23.6" (600 mm) triple grouser shoe, with dozer. Based on machine equipped with — Arm: 7'10" (2.38 m)
 Bucket: 0.7 yd³ (0.5 m³) Bucket Weight: (SAE Heaped) 740 lbs. (335 kg) Counter Weight: 7,500 lbs. (3,400 kg)

OPTIONAL EQUIPMENT - ARM 2 - STD. COUNTER WEIGHT

B	A C	LIFT POINT RADIUS								AT MAX. REACH		
		5' (1.5 m)		10' (3.0 m)		15' (4.6 m)		20' (6.1 m)		RADIUS		
												
25' (7.6 m)	lb kg									*3,570 *1,610	*3,570 *1,610	12' 2" (3.70 m)
20' (6.1 m)	lb kg					*6,310 *2,860	*6,310 *2,860			*2,810 *1,270	*2,810 *1,270	18' 2" (5.55 m)
15' (4.6 m)	lb kg					*7,080 *3,210	6,980 3,160	*5,290 *2,400	4,130 1,870	*2,640 *1,190	*2,640 *1,190	21' 5" (6.55 m)
10' (3.0 m)	lb kg			*12,270 *5,560	*12,270 *5,560	*8,650 *3,920	6,490 2,940	6,770 3,070	3,950 1,790	*2,700 *1,220	*2,700 *1,220	23' 2" (7.07 m)
5' (1.5 m)	lb kg			*17,280 *7,840	10,940 4,960	10,410 4,720	5,890 2,670	6,500 2,940	3,700 1,680	*2,960 *1,340	2,720 1,230	23' 8" (7.23 m)
Ground Level	lb kg			*16,370 *7,420	10,190 4,620	9,920 4,500	5,460 2,470	6,270 2,840	3,500 1,580	*3,500 *1,580	2,750 1,240	23' 2" (7.06 m)
-5' (-1.5 m)	lb kg	*11,750 *5,320	*11,750 *5,320	*17,400 *7,890	10,110 4,580	9,730 4,410	5,300 2,400	6,190 2,800	3,420 1,550	*4,620 *2,090	3,090 1,400	21' 4" (6.52 m)
-10' (-3.0 m)	lb kg	*18,220 *8,260	*18,220 *8,260	*14,190 *6,430	10,350 4,690	*9,560 *4,330	5,390 2,440			*7,230 *3,270	4,100 1,850	18' 0" (5.51 m)



Rating over front



Rating over side / 360 degrees

Notes:

- Do not attempt to lift or hold any load that exceeds these rated values at their specified load radii and heights. Weight of all accessories must be deducted from the above lifting capacities.
- Lifting capacities assume a machine standing on a level, firm, and uniform supporting surface. Operator must make allowance for job conditions such as soft or uneven ground, out of level conditions, side loads, sudden stopping of loads, hazardous conditions, inexperienced personnel, weight of various other buckets, lifting slings, attachments, etc.
- Ratings at bucket lift hook.
- The above rated loads are in compliance with SAE Hydraulic Excavator Lift Capacity Standard J 1097. They do not exceed 87% of hydraulic lifting capacity or 75% of tipping load. Rated loads marked with an asterisk (*) are limited by hydraulic capacity rather than tipping load.
- Operator should be fully acquainted with the Operator's and Maintenance Manuals before operating this machine. Rules for safe operation of equipment should be followed at all times.
- Capacities apply only to the machine as originally manufactured and normally equipped by KOBELCO Construction Machinery America LLC.

140SR DOZER CAPABILITY



In addition to powerful digging and fine grading capabilities, the new 140SR excavator offers an optional 2-way dozer blade and extra-heavy counter weight. This makes the 140SR the best choice for digging, grading, dozing and back-filling. Controlled from inside the cab, the 8' 6" wide blade is 22" (570 mm) high and offers 27" (686 mm) of lift. Lift/lower capabilities are controlled with a single lever from inside the cab.

With a robust lift cylinder and boxed-frame beam supports; the durable dozer blade makes the 140SR the most versatile excavator in its class.

The Kobelco 140SR excavator is the customer's best choice for working in urban construction sites, road building, underground utility work and general site prep and finishing.

The perfect combination for out-performing the competition.



140SR STANDARD AND OPTIONAL EQUIPMENT

STANDARD EQUIPMENT

- AM/FM radio
- Arm, 9' 4" (2.84 m) with rock guard, tapped blocks, breaker ready
- Audible warning system for high coolant temperature, low engine oil pressure, clogged air filter and oil replacement interval
- Automatic swing and travel parking brakes
- Automatic engine accel/decel feature
- Automatic engine & hydraulic warm up function
- Belly pan guard
- Boom: 15' 5" (4.72 m)
- Boom and arm holding (anti-drift) valves
- Breaker valve with flow control
- Cab is die formed, modular steel full-vision, sound insulated, with viscous silicon-filled mounts, windshield wiper, heater and defroster, cigarette lighter, ashtray, floor mat, cab light, control lever lock, tinted skylight with damper cylinder
- Climate control air conditioning/heating system
- Combined one-way or two-way auxiliary hydraulics with hand controls
- Counter weight 7,500 lbs (3,400 kg)
- Display monitor mounted on multi-function console provides status of following: aging of engine oil, fuel and hydraulic filters, system status, engine preheat, low engine oil pressure, engine coolant temperature, air cleaner restriction, battery charging, fuel level, CPU error and tachometer. Beneath monitor are switches for auto-decel, windshield washer and wiper, mode selector, one/two pump auxiliary hydraulics and swing flashers
- Dual element air cleaner
- Exhaust Gas Recirculation (EGR) system
- Electric horn
- Emergency electronic bypass
- Engine shuts down automatically if low oil pressure occurs
- Flanged brass bucket bushing
- Floor mat - removable, washable, replaceable
- Heavy duty batteries (2 x 12 volt 80 AH)
- Independent travel
- Integrated Noise Reduction System
- Lifetime lubricated track rollers, idlers and sprockets, grease cylinder track adjuster, track link disassembly mechanism, long pitch sealed and strutted track links.
- Long-life attachment bushings. Flanged bushing assembly at bucket pivot.
- Mitsubishi Engine, model D04FR-74kW
- Mode selection:
 - H Mode—Heavy-duty excavation work
 - S Mode—Standard digging and loading work
 - B Mode—Breaker work (1-way flow)
 - A Mode—Demolition work (2-way/2-pump flow)
- Standard-Duty X-Frame undercarriage
- Power outlet, 24 volt to 12 volt converter

- Proportional auto accel system
- Removable cleanout screens for radiator & condensers
- Removable travel levers with toe tabs
- Seven (7) track rollers
- Self-lubricating bushings in boom foot and boom hoist cylinders
- Service diagnostics:
 - Computer system displays 68 service items and 60 event fault code memory - accessible from cab
- Starting motor (24 v/5.0 KW) 30 amp alternator
- Straight travel system
- Storage compartment for manuals
- Suspension seat—7-way adjustable w/ safety belt
- Swing and travel automatic parking brakes
- Swing priority (trenching system) functions automatically
- Swing shockless valve
- Track shoes: 23.6" (600 mm) semi-triple bar grouser
- Travel Alarm
- Travel—two speed with automatic shift
- Two lever control for boom, arm, bucket and swing; pilot operated wrist controls and foot pedals
- Warm up function of engine and hydraulic system, functions automatically
- Work lights – two front and two rear

OPTIONAL EQUIPMENT

- Arm, short, 7' 10" (2.38 m)
- Boom and arm load (lock) valves
- Buckets (Esco & Hensley)
- Counter weight, Add-on, 1,290 lbs (585 kg)
- Combined one-way or two-way auxiliary hydraulics with foot controls
- Control pattern changer (ISO/BHL)
- Dozer Blade (22" blade height)
- Hydraulic oil for cold or tropical environments
- Independent low-flow rotation valve w/piping
- Quick Couplers (JRB & Hendrix)
- Rain visor
- Track shoes: 19.7" (500 mm) semi-triple bar grouser with rubber pads
- Track shoes: 27.6" (700 mm) semi-triple bar grouser
- Vandalism guards

NOTE: Due to our policy of continual product improvement, all designs and specifications are subject to change without advance notice.

WORLD CLASS PRODUCTS DEMAND WORLD CLASS DEALERS

The purchase of a Kobelco excavator isn't the end, it's the beginning of our relationship together. Consider your local Kobelco dealer as your partner in productivity who will work with you to supply your business needs. Whether you need assistance in selecting the right model for your operation or developing an affordable leasing or financing plan through CNH Capital, your Kobelco dealer can offer you sound advice because he has decades of heavy equipment experience.

Downtime can happen at any time. And that's the best time to know you've got your Kobelco dealer's full service capabilities. He's the 'one stop shop' who is just down the street. Genuine Kobelco parts and all makes parts coverage, where and when you need them. Factory-trained service technicians, warranty experts and parts manager who are excavator experts. Fully equipped service vehicles which can bring responsive support to you quickly, to get you back up and running. Even customized professional maintenance programs, operator and technical training. You want your Kobelco equipment investment to be productive and keep your operation moving. **So do we.**



Your business deserves nothing less than world class product, supported by a world class business partner. That's your Kobelco dealer—your partner in productivity.

KOBELCO®

Kobelco Construction Machinery America LLC
245 E. North Avenue
Carol Stream, IL 60188-2021
866-726-3396 Toll Free
630-260-4000
630-260-4304 Fax

www.kobelcoamerica.com

Products represented in this brochure may include optional equipment.

Note: Due to our policy of continual product improvement, all design, materials and/or specifications are subject to change without advance notice and without liability therefor. Specifications are applicable to units sold in Canada, the United States, its territories and possessions, and may vary outside these areas.

Safety begins with a thorough understanding of the equipment. Always make sure you and your operators read the Operator's Manual before using the equipment. Pay close attention to all safety and operating decals and never operate machinery without all shields, protective devices and structures in place.

