

# Kobelco 7055-2

## 55 Tonne Crawler Crane

### Range Diagram

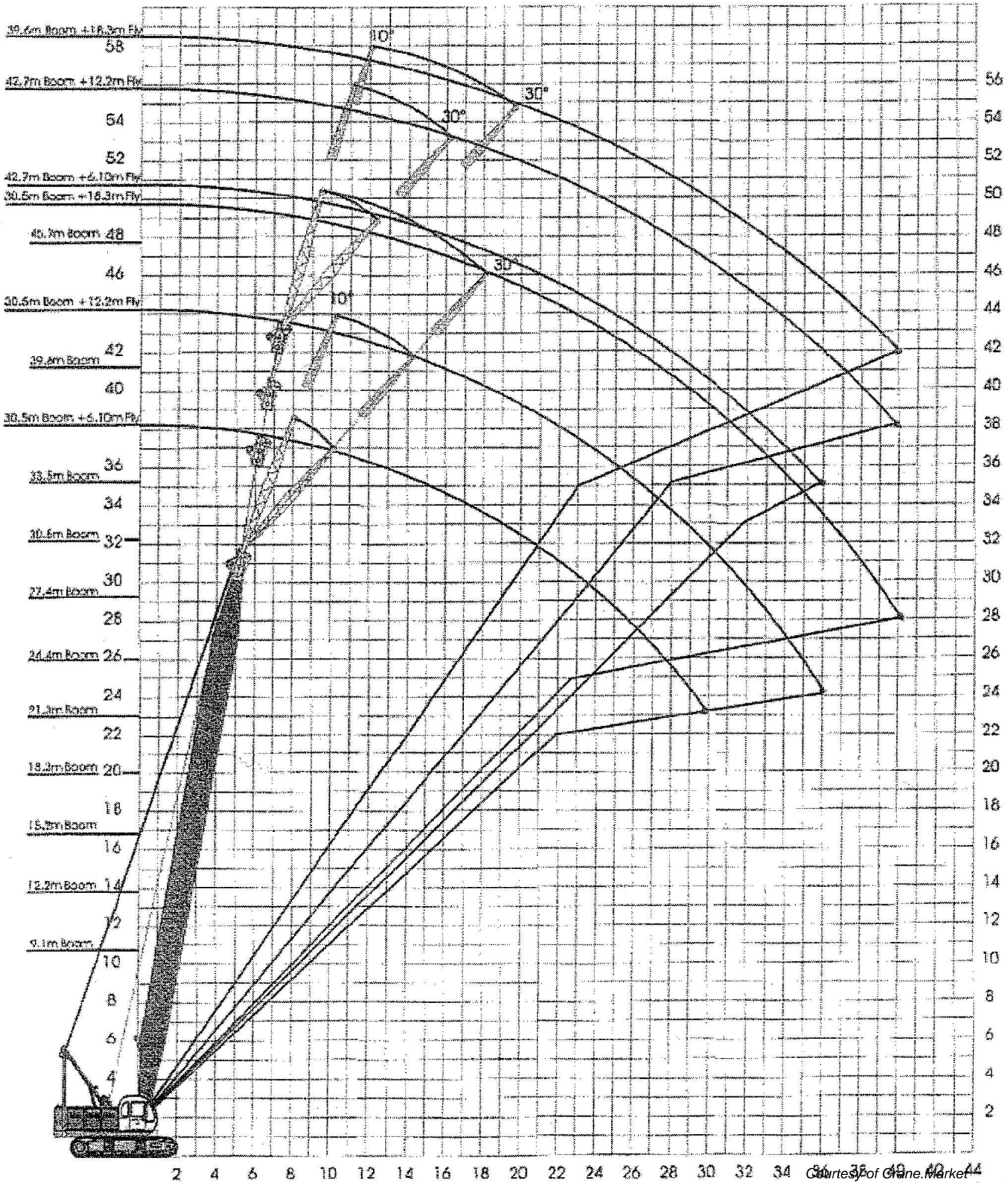

# KOBELCO 7055-2

## HEAVY DUTY BASE MACHINE FOR LIFTING & FOUNDATION WORK

Maximum Lift capacity 55 Metric Tonne

Maximum Crane Boom Length 51.8 Metres

Maximum Crane Boom 39.6 Metres & Fixed Fly 18.3m

Maximum Tower Boom 42.4 Metres & Luffing Fly 29.0m

A mega-powered crane equipped with precision control capability.  
Engine Speed Sensing system for steady, effortless operation.

Powerful engine and strong line pull make light work of heavy duty tasks.

Precise, full hydraulic control gives crane performance idea for construction tasks.

Maximum line speed of 100 m/min for main and auxiliary winches.

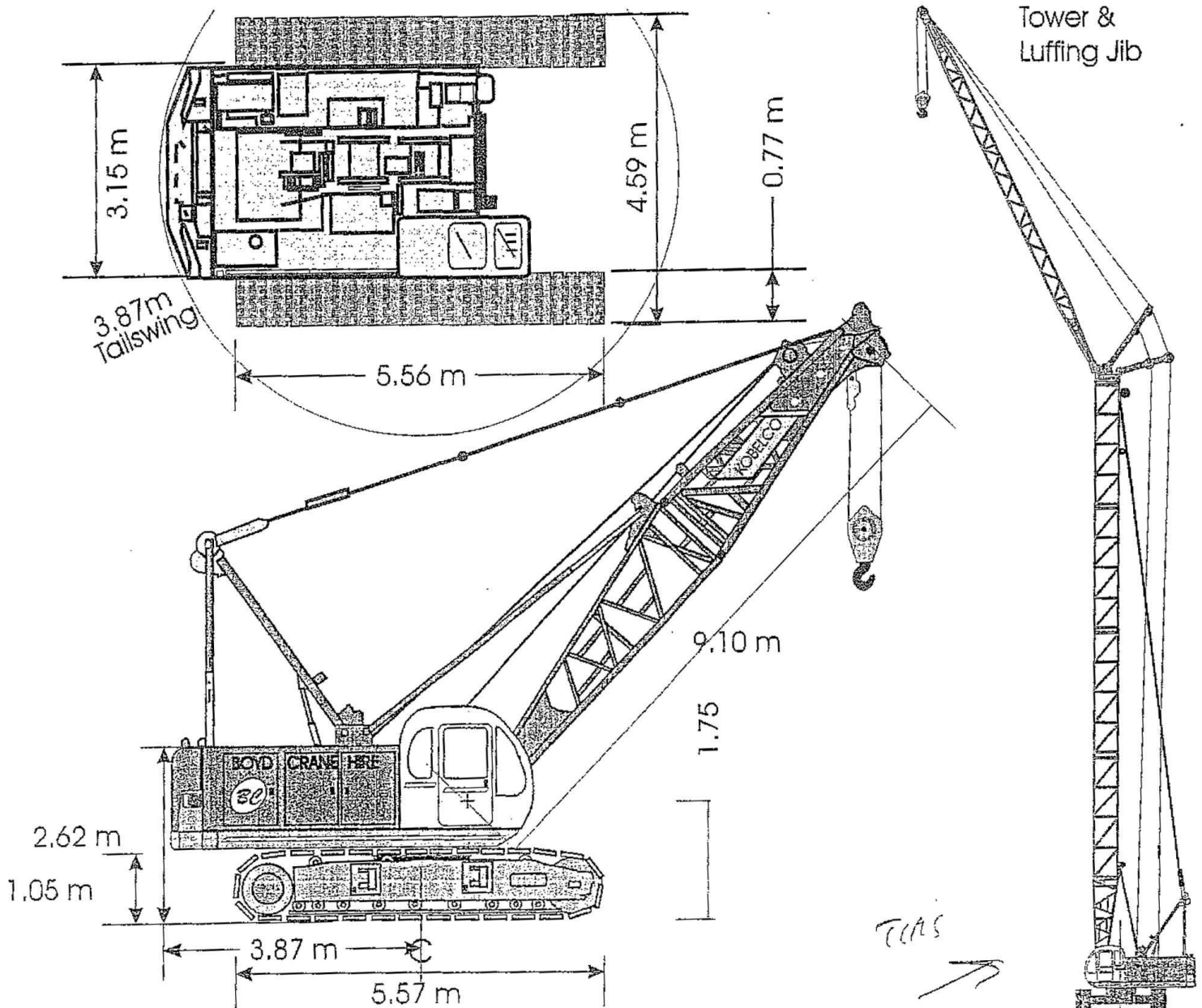

# 7055-2 Crawler Crane, Main Boom



LIFTING RANGE  
360°

Crawlers fully extended

RADIUS METRES	BOOM LENGTH											
	9.1	15.2	24.4	27.4	30.48	33.53	36.6	39.6	42.67	45.7	48.8	51.1
3.0	55.0											
3.7	55.0											
4.0	50.7	50.7										
4.5	44.5	44.4										
5.0	38.5	38.3	31.6									
5.5	32.7	32.6	28.4									
6.0	28.7	28.5	22.4	27.4	24.2							
7.0	22.8	22.6	18.5	22.4	22.3	21.3	19.2					
8.0	18.9	18.6	15.6	18.4	18.4	18.3	18.2	17.4	15.8			
9.0	16.1	15.8	13.5	15.6	15.5	15.4	15.4	15.3	15.2	13.2	13.2	
10.	15.9	13.7	10.5	13.4	13.4	13.3	13.2	13.1	13.1	13.0	12.9	11.8
12		10.7	8.5	10.4	10.4	10.3	10.2	10.1	10.0	10.0	9.9	9.8
14		8.8	7.1	8.4	8.4	8.3	8.2	8.1	8.0	8.0	7.9	7.8
16		8.5	6.1	7.0	7.0	6.9	6.8	6.7	6.6	6.5	6.5	6.3
18			5.3	6.0	5.9	5.8	5.7	5.6	5.5	5.5	5.4	5.3
20			4.6	5.2	5.1	5.0	4.9	4.8	4.7	4.6	4.5	4.4
22			4.5	4.5	4.4	4.3	4.2	4.1	4.0	3.9	3.9	3.7
24				4.0	3.9	3.8	3.7	3.6	3.5	3.4	3.3	3.2
26				3.8	3.4	3.3	3.2	3.1	3.0	2.9	2.8	2.7
28					3.1	3.0	2.9	2.8	2.7	2.6	2.5	2.4
30						2.6	2.5	2.4	2.3	2.2	2.1	2.0
32						2.5	2.3	2.2	2.1	2.0	1.9	1.8
34							2.1	1.9	1.8	1.7	1.6	1.5
36								1.7	1.5	1.4	1.3	1.1
38									1.3	1.2	1.1	

Load Weight Metric Tonnes

**⚠ Caution Hooks & Lifting Equipment to be added to load weight.  
WARNING: VERIFY WITH CHARTS IN CRANE PRIOR TO LIFTING**

Deductions when fitted.

Aux. Hook 160 kg Aux. Boom Nose 120kg

Main Hook 35t 500kg

Main Hook 55t 650 kg

7055-2

### Notes:

1. Operating Radius is the horizontal distance from the centreline of rotation a vertical line through the centre line of gravity of the load.
2. Rated loads included in the charts are the maximum allowable freely suspended loads at a given tower length, tower and jib angle and load radius, and have been determined for the machine standing level on firm supporting surface under ideal operating conditions. The user must limit or de-rate rated loads for adverse conditions (such as soft or uneven ground, out-of-level conditions, wind, side loads, pendulum action, jerking or sudden stopping of loads, inexperience of personnel, multiple machine lifts, travelling with a load).
3. Capacities do not exceed 75% of minimum tipping loads. Some of the rated crane loads are based on the structural strength and over load could damage the tower jib and frame etc. without tipping.
4. Areas on rated crane load table where no rating are shown operation is not intended or approved.
5. The load which can be lifted actually is obtained by deducting weight of hook block, slings and other load handling accessories from the rated crane load.
6. For arrangements of the tower, jib and guy lines and reeving of the tower, hoist rope and jib hoist rope, strictly observe the instruction of the operators manual.
7. Max. hoisting load.
8. The 6.6 ton ball must not be used with 16.8m. Jib weights check if required see p7-32 Tower manual.
9. Confirm working range drawings measurements with rating chart radius.

No. of parts of line	1	2
Max. load (metric ton)	6	12

# Luffing Tower Working Range

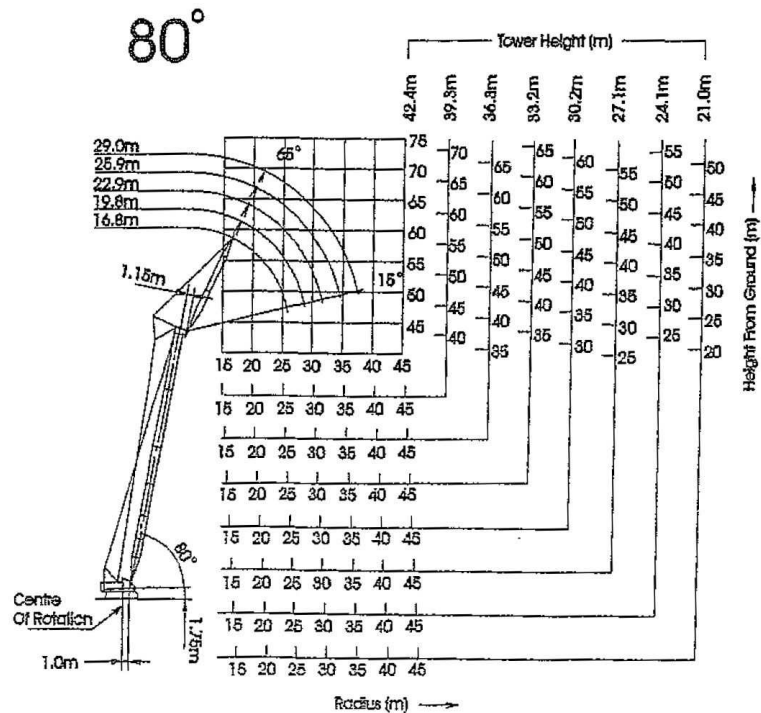
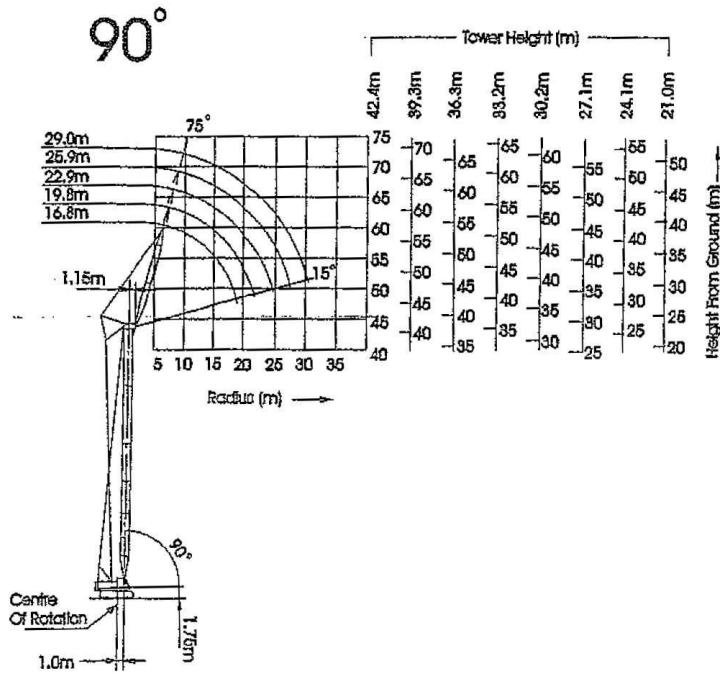



# Luffing Tower

75°

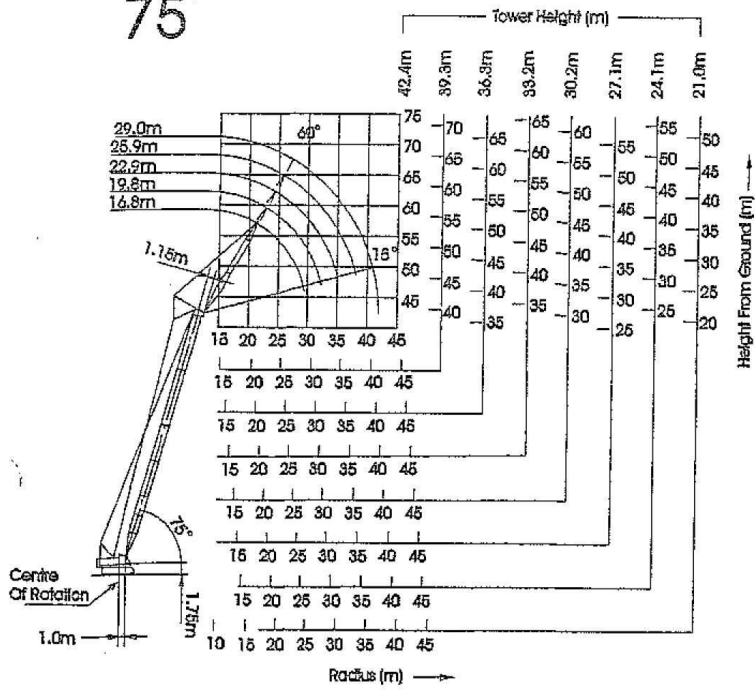

70°

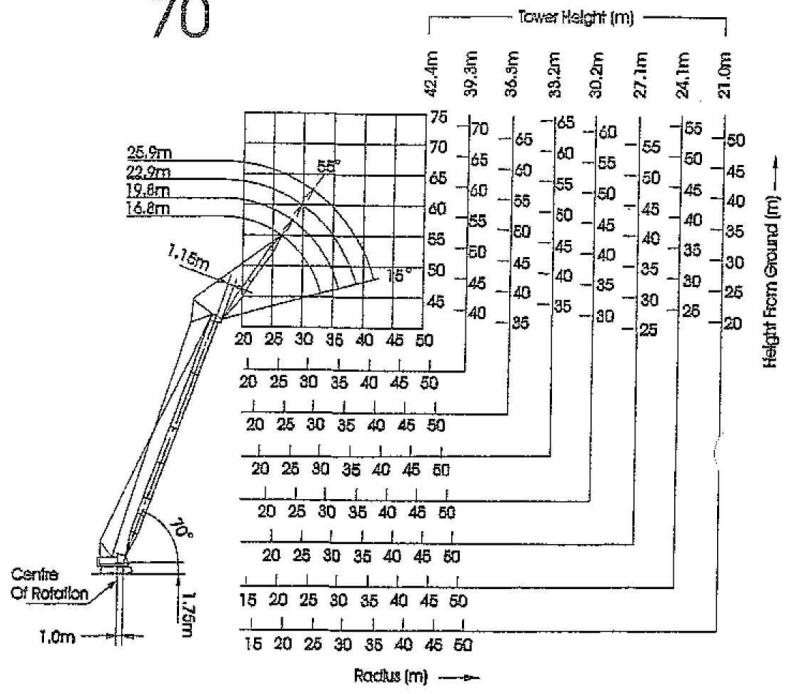

60°

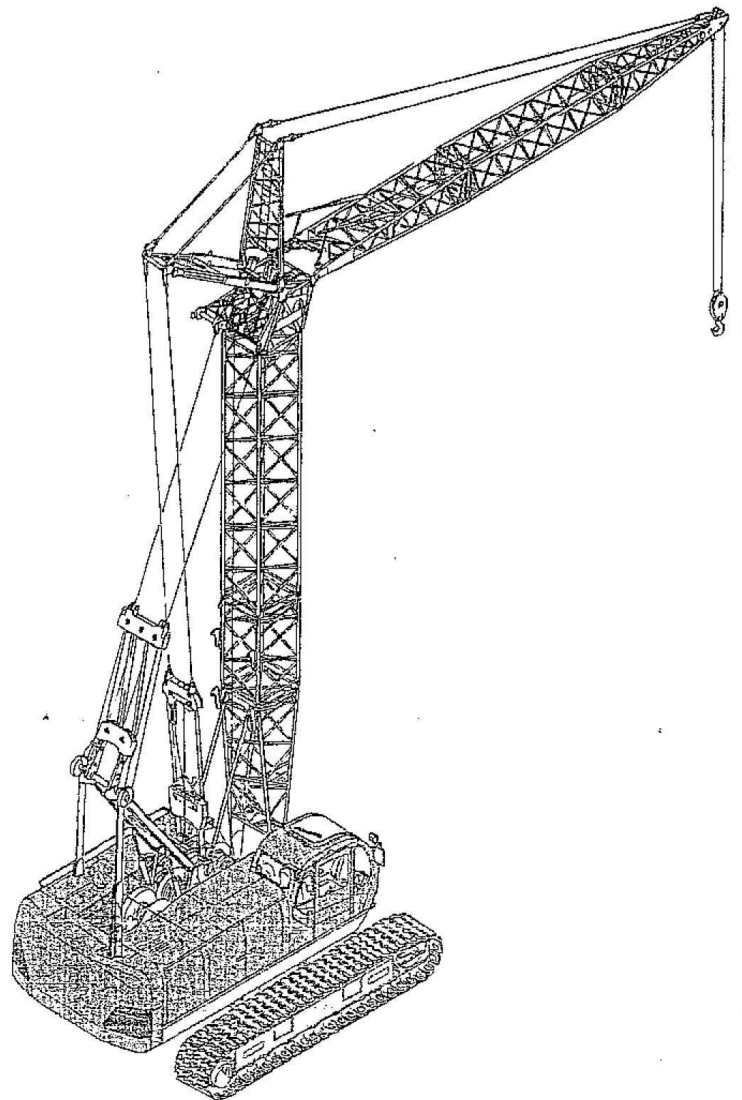
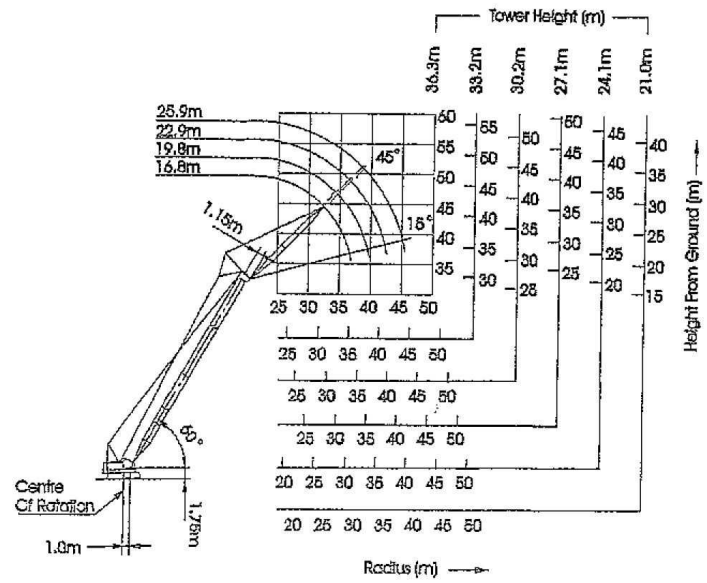

# Luffing Tower- Luffing Jib Lifting Capacities

## 24.1 m Luffing Tower 90°-80°-70° Luffing Jib 16.8m, 19.8m & 22.9m

Rated loads in metric tonnes Crawlers fully extended

Operating Radius (m)	24.1 Tower									
	16.8 m Jib			19.8m Jib			22.9m Jib			
	Tower Angle			Tower Angle			Tower Angle			
	90°	75°	60°	90°	75°	60°	90°	75°	60°	
6.0	12.0t@6.5m									
7.0	12.0			12.0t@7.3m						
8.0	12.0			12.0			11.5t@8.1m			
9.0	12.0			12.0			11.2			
10.0	12.0			11.8			11.0			
12.0	10.7			10.5			10.3			
14.0	9.60			9.40			9.20			
16.0	8.20	6.7t@16.7m		8.10			8.10			
18.0	6.20	6.20		7.20	6.0t@18.3m		7.20	5.3t@19.8m		
20.0	5.5t@18.3m	5.40		5.90	5.30		6.30	5.30		
22.0		4.80		4.6t@21.3m	4.70		5.30	4.70		
24.0		4.30	3.3t@25.9m		4.30		4.10	4.20		
26.0		4.2t@24.6m	3.20		3.80		3.9t@24.2m	3.80		
28.0			2.90		3.6t@27.5m		2.8t@28.1m	3.50		
30.0			2.70				2.60	3.20	2.5t@30.2m	
32.0			2.7t@30.3m				2.40	3.1t@30.4m	2.30	
34.0							2.3t@33.2m		2.10	
36.0									2.00	
38.0									2.0t@36.2m	

Load Weight Metric Tonnes



**Caution Hooks & Lifting Equipment to be added to load weight.**  
**WARNING: VERIFY WITH CHARTS IN CRANE PRIOR TO LIFTING**

Deductions when fitted.

Aux. Hook 160 kg 6.6t capacity Main Hook 19t 500kg 12t capacity

**Kobelco**

Courtesy of Crane Market

# Luffing Tower- Luffing Jib Lifting Capacities

## 27.1m Luffing Tower 90°-80°-70° Luffing Jib 22.9 & 25.9m

Rated loads in metric tonnes Crawlers fully extended

Operating Radius (m)	27.1 m Tower					
	22.9m Jib			25.9m Jib		
	Tower Angle			Tower Angle		
	90°	75°	60°	90°	75°	60°
8.0	11.5t@8.1m			8.6t@8.9m		
9.0	11.2			8.60		
10.0	11.0			8.40		
12.0	10.3			8.20		
14.0	9.20			7.70		
16.0	8.10			7.10		
18.0	7.20			6.50		
20.0	6.30	4.9t@20.6m		5.90		
22.0	5.30	4.50		5.30	4.4t@22.1m	
24.0	4.10	4.00		4.70	4.00	
26.0	3.9t@24.2m	3.70		4.00	3.60	
28.0		3.30		3.3t@27.2m	3.20	
30.0		3.00	2.1t@31.7m		3.00	
32.0		2.9t@31.2m	2.00		2.70	1.7t@33.9m
34.0			1.90		2.50	1.70
36.0			1.70		2.5t@34.2m	1.60
38.0			1.6t@37.6m			1.40
40.0						1.30
42.0						1.3t@40.6m

**Load Weight Metric Tonnes**

**Caution Hooks & Lifting Equipment to be added to load weight.**  
**WARNING: VERIFY WITH CHARTS IN CRANE PRIOR TO LIFTING**

Deductions when fitted.

Aux. Hook 160 kg 6.6t capacity Main Hook 19t 500kg 12t capacity

**Kobelco**

*Courtesy of Crane.Market*

# Luffing Tower- Luffing Jib Lifting Capacities

## 30.2m Luffing Tower 90°-80°-70° Luffing Jib 25.9m & 29.0m

Rated loads in metric tonnes Crawlers fully extended

Operating Radius (m)	30.2 m Tower					
	25.9m Jib			29.0m Jib		
	Tower Angle			Tower Angle		
	90°	75°	60°	90°	80°	70°
8.0	8.6t@8.9m					
9.0	8.60			6.2t@9.7m		
10.0	8.40			6.20		
12.0	8.20			6.20		
14.0	7.70			6.00		
16.0	7.10			5.60		
18.0	6.40			5.10	5.4t@19.6m	
20.0	5.90			4.60	5.20	
22.0	5.30	4.0t@22.9m		4.20	4.60	
24.0	4.70	3.80		3.80	4.10	
26.0	4.00	3.40		3.50	3.70	
28.0	3.3t@27.2m	3.10		3.20	3.40	2.6t@29.0m
30.0		2.80		2.80	3.10	2.50
32.0		2.60		2.8t@30.1m	2.80	2.30
34.0		2.40	1.3t@35.4m		2.60	2.00
36.0		2.3t@34.9m	1.30		2.5t@35.3m	1.90
38.0			1.20			1.70
40.0			1.1t@40.0m			1.60
42.0						1.5t@40.4m

**Load Weight Metric Tonnes**

**Caution Hooks & Lifting Equipment to be added to load weight.**  
**WARNING: VERIFY WITH CHARTS IN CRANE PRIOR TO LIFTING**

Deductions when fitted.

Aux. Hook 160 kg 6.6t capacity Main Hook 19t 500kg 12t capacity

**Kobelco**



# Luffing Tower- Luffing Jib Lifting Capacities

## 33.2m Luffing Tower 90°-80°-70° Luffing Jib 25.9m & 29.0m

Rated loads in metric tonnes Crawlers fully extended

Operating Radius (m)	33.2 m Tower					
	25.9m Jib			29.0m Jib		
	Tower Angle			Tower Angle		
	90°	80°	70°	90°	80°	70°
6.0						
7.0						
8.0	8.6t@8.9m					
9.0	8.60			6.2t@9.7m		
10.0	8.30			6.20		
12.0	8.00			6.20		
14.0	7.70			6.00		
16.0	7.10			5.60		
18.0	6.40	5.5t@18.9m		5.10		
20.0	5.80	5.10		4.60	5.0t@20.1m	
22.0	5.30	4.60		4.20	4.50	
24.0	4.70	4.10		3.80	4.00	
26.0	4.00	3.70		3.50	3.60	
28.0	3.3t@27.2m	3.30	2.5t@28.3m	3.10	3.30	
30.0		3.10	2.30	2.80	3.00	2.2t@30.1m
32.0		2.80	2.10	2.8t@30.1m	2.70	2.00
34.0		2.7t@32.9m	1.90		2.50	1.80
36.0			1.70		2.3t@35.9m	1.60
38.0			1.60			1.50
40.0			1.5t@38.5m			1.40
42.0						1.3t@41.4m

Load Weight Metric Tonnes

**Caution Hooks & Lifting Equipment to be added to load weight.**  
**WARNING: VERIFY WITH CHARTS IN CRANE PRIOR TO LIFTING**

Deductions when fitted.

Aux. Hook 160 kg 6.6t capacity Main Hook 19t 500kg 12t capacity

**Kobelco**

Courtesy of CraneMarket

# Luffing Tower- Luffing Jib Lifting Capacities

## 36.3m Luffing Tower 90°-80°-70° Luffing Jib 25.9m & 29.0m

Rated loads in metric tonnes Crawlers fully extended

Operating Radius (m)	36.3 m Tower					
	25.9m Jib			29.0m Jib		
	Tower Angle			Tower Angle		
	90°	80°	70°	90°	80°	70°
8.0	8.60t@8.9m					
9.0	8.50			6.20t@9.7m		
10.0	8.30			6.20		
12.0	8.00			6.20		
14.0	7.70			6.00		
16.0	7.10			5.60		
18.0	6.40	5.20t@19.4m		5.10		
20.0	5.80	5.00		4.60	4.70t@20.7m	
22.0	5.30	4.40		4.20	4.40	
24.0	4.70	4.00		3.80	3.90	
26.0	3.90	3.60		3.50	3.50	
28.0	3.30t@27.2m	3.20	2.10t@29.4m	3.10	3.20	
30.0		3.00	2.10	2.80	2.90	1.90t@31.1m
32.0		2.70	1.90	2.80t@30.1m	2.70	1.80
34.0		2.50t@33.5m	1.70		2.40	1.60
36.0			1.50		2.30	1.40
38.0			1.40		2.20t@36.4m	1.30
40.0			1.30t@39.5m			1.20
42.0						1.10t@42.0m

Load Weight Metric Tonnes

 **Caution Hooks & Lifting Equipment to be added to load weight.**  
**WARNING: VERIFY WITH CHARTS IN CRANE PRIOR TO LIFTING**

Deductions when fitted.

Aux. Hook 160 kg 6.6t capacity Main Hook 19t 500kg 12t capacity

# Luffing Tower- Luffing Jib Lifting Capacities

## 39.3m Luffing Tower 90°-80°-70° Luffing Jib 25.9m & 29.0m

Rated loads in metric tonnes Crawlers fully extended

Operating Radius (m)	39.3 m Tower					
	25.9m Jib			29.0m Jib		
	Tower Angle			Tower Angle		
	90°	80°	70°	90°	80°	70°
8.0	6.70t@8.9m					
9.0	6.70			6.20t@9.7m		
10.0	6.70			6.20		
12.0	6.70			6.20		
14.0	6.70			6.00		
16.0	6.70			5.60		
18.0	6.40	4.9t@19.9m		5.00		
20.0	5.80	4.80		4.60	4.4t@21.2m	
22.0	5.30	4.30		4.20	4.20	
24.0	4.70	3.80		3.80	3.80	
26.0	3.90	3.50		3.40	3.40	
28.0	3.30t@27.2m	3.10		3.10	3.10	
30.0		2.90	1.70t@30.4m	2.80	2.80	
32.0		2.60	1.60	2.80t@30.1m	2.60	1.50t@32.1m
34.0		2.40t@34.0m	1.40		2.30	1.30
36.0			1.30		2.20	1.20
38.0			1.10		2.10t@36.9m	1.10t@38.0m
40.0			1.10t@39.0m			

**Load Weight Metric Tonnes**

**Caution Hooks & Lifting Equipment to be added to load weight.**  
**WARNING: VERIFY WITH CHARTS IN CRANE PRIOR TO LIFTING**

Deductions when fitted.

Aux. Hook 160 kg 6.6t capacity Main Hook 19t 500kg 12t capacity



# Luffing Tower- Luffing Jib Lifting Capacities

## 42.4m Luffing Tower 90°-80°-70° Luffing Jib 25.9m & 29.0m

Rated loads in metric tonnes Crawlers fully extended

Operating Radius (m)	42.4 m Tower						
	25.9m Jib			29.0m Jib			
	Tower Angle			Tower Angle			
	90°	80°	70°	90°	80°	75°	
8.0	6.5t@8.9m						
9.0	6.50			6.0t@9.7m			
10.0	6.50			6.00			
12.0	6.50			6.00			
14.0	6.40			6.00			
16.0	6.30			5.60			
18.0	6.20			5.00			
20.0	5.80	4.6t@20.4m		4.60	4.1t@21.7m		
22.0	5.30	4.10		4.10	4.10		
24.0	4.70	3.70		3.80	3.60		
26.0	3.90	3.30		3.40	3.30	2.4t@27.6m	
28.0	3.3t@27.2m			3.10	3.00	2.30	
30.0		2.80	1.4t@31.4m		2.80	2.70	2.10
32.0		2.50	1.30	2.8t@30.1m		2.50	1.90
34.0		2.30	1.20		2.30	1.70	
36.0		2.3t@34.5m		1.1t@35.5m		2.10	1.50
38.0					2.0t@37.5m		1.40
40.0						1.20	
42.0						1.2t@41.1m	

**Load Weight Metric Tonnes**

**Caution Hooks & Lifting Equipment to be added to load weight.**  
**WARNING: VERIFY WITH CHARTS IN CRANE PRIOR TO LIFTING**

Deductions when fitted.

Aux. Hook 160 kg 6.6t capacity Main Hook 19t 500kg 12t capacity

**Kobelco**