

KOBELCO

HYDRAULIC CRAWLER CRANE

CKE600

Max. Lifting Capacity: 60.0 t at 3.0 m

Max. Boom Length: 51.8 m

Max. Fixed Jib Combination: 39.6 + 18.3 m

CKE700

Max. Lifting Capacity: 70.0 t at 3.1 m

Max. Boom Length: 54.9 m

Max. Fixed Jib Combination: 42.7 + 18.3 m

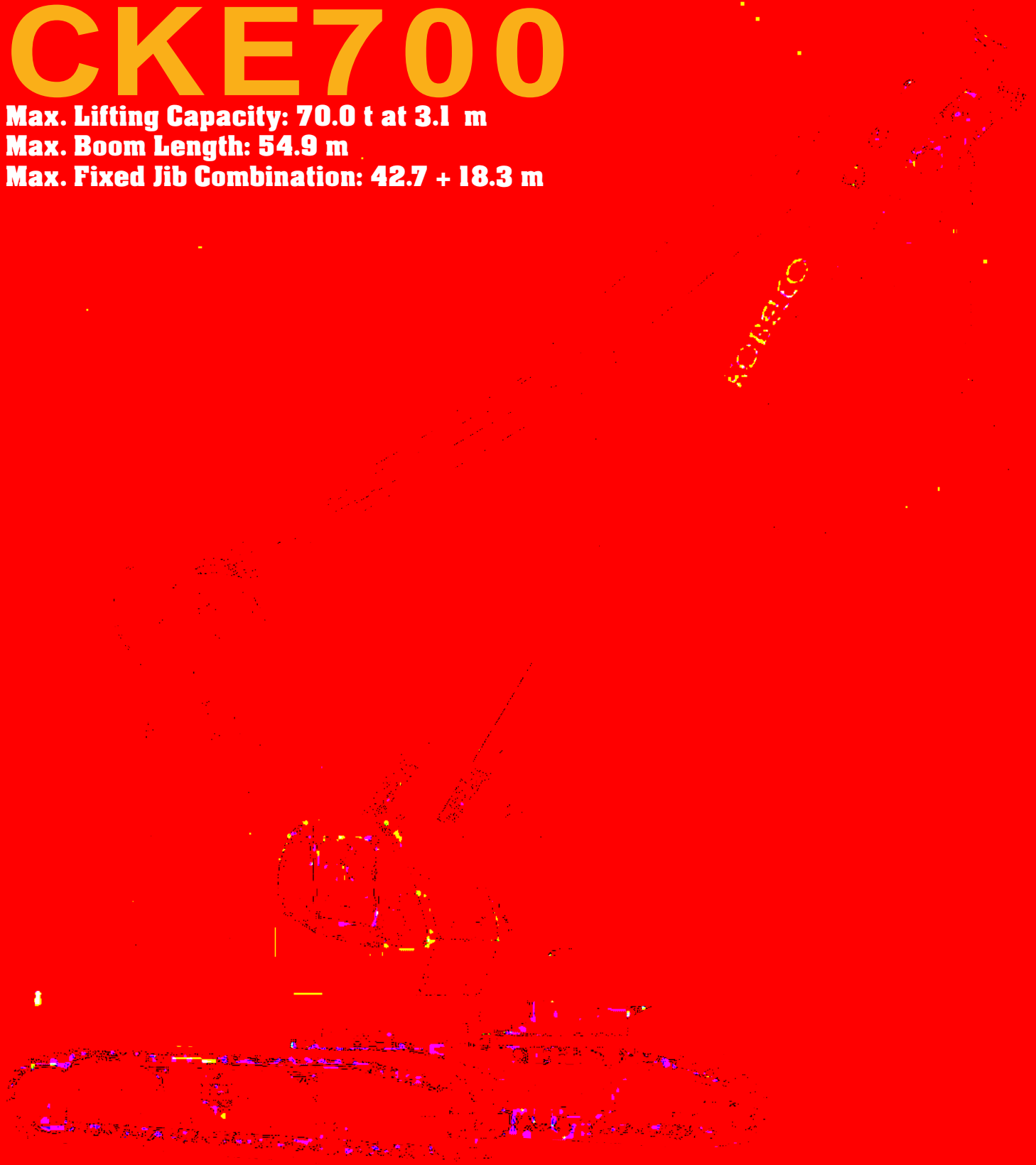

Photos in this catalog may include optional items.

Courtesy of Crane.Market

KOBELCO's awesome new expression of power, speed and efficiency.

The CKE600 and CKE700 crawler cranes from KOBELCO take advantage of new technologies to raise performance to new heights. Winches with extremely powerful line-pull handle the toughest jobs, while the innovative "wet-type" multi-disc braking system provides safe and sure control with minimal maintenance. A large drum capacity promotes ultra-smooth operation and enhanced component service life. An optional full-sized third drum enables the use of an impressive selection of attachments. Add these new features to the renowned power and reliability of KOBELCO cranes, and you have the ideal combination of lifting performance, economical operation and durability.

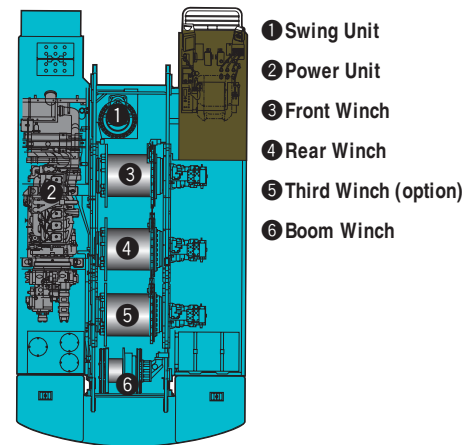
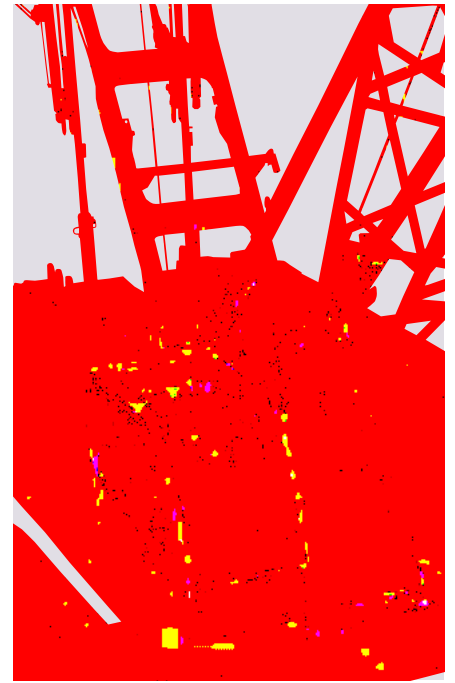

PERFORMANCE

Innovative Wet-Type Disc Brake System

KOBELCO's new oil cooled wet-type multi-disc brake system is first in its class and provides quiet, dependable braking power. Multiple discs are self-adjusting and self-equalizing. Forced oil circulation keeps brake temperatures cooler during long, continuous operations and maximizes smooth brake operation. The completely enclosed system eliminates the possibility of outside contamination, providing years of problem-free service life. The low brake pedal effort reduces operator fatigue when the machine is working in the optional free-fall mode.

Wet-type disc brake installed in winch drum:

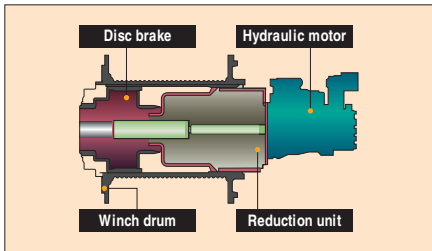

Conventional, externally-fitted band brake:

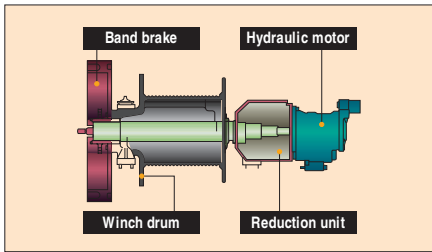

Extremely Powerful Winches

The powerful winches boast a rated single line pull of 8 tf, reducing the number of parts of line involved and improving hoisting speed. The result realizes dynamic lifting capacities and continuous trouble-free operations.

Large Capacity Drums

KOBELCO's innovative internal disc brake system allows for the use of wider drums to avoid the chance of uneven winding, while extending the service life of the wire rope. An optional third drum is now full sized, allowing for more attachment options and better operation coordination.

On-Site Maneuverability

Independently driven hydraulic travel motors with planetary reduction units provide three steering modes (differential steering, skid steering and counter rotation) for optimal on-site maneuverability.

Travel motors are less than track shoe width, protecting them from damage.

CONTROLS & CAB

Roomy, Comfortable Cab

Operator comfort is ensured by vibration-reducing rubber cab mounts a fully adjustable, upholstered seat, and an air conditioner with fresh-air vents. Reinforced tinted glass windows reduce glare, and the semi-short levers and other control devices are ergonomically located and arranged for easy control.

Precise Operation with Responsive Control

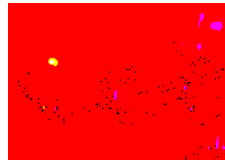

Full-hydraulic technology delivers quick, efficient operation with excellent precision. Pilot pressure-

assisted control allows you to control the speed and power of each function in proportion to lever movement.

Power Lowering and Optional Free-Fall

A choice of either power lowering mode or free-fall mode can be selected for the winch drum according to requirements.

Inching Control Switch

The red switch on the boom lever grip allows easy inching control for hoist, boom hoist, and travel that the operator can activate without taking his hands off the boom hoist lever.

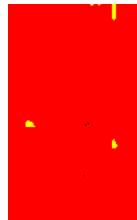

Drum Speed Controller

Speeds for main winch, auxiliary winch and boom hoist can be set independently with trimmer controls.

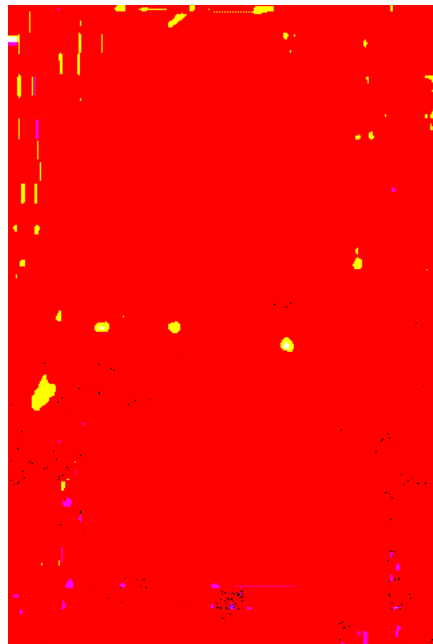

Electric Throttle Control



Sensitive engine control is assured by an electric throttle with a twist grip.

TRANSPORTATION

Transportation

- Crawlers retracted for transportation.

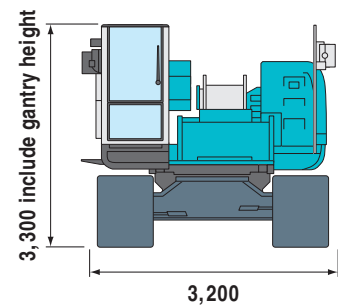

Self-Erecting and Transportation

KOBELCO has designed machines to be assembled and disassembled without the need of an assist crane by employing a counterweight self-handling system. The complete crane can be transported on three trucks (each under 45 tons) and assembled by three men in less than half a day.

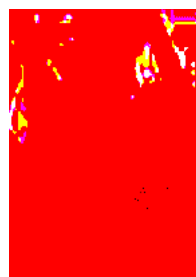

Gantry Raising from Cab

Gantry raising cylinder installed to allow simple gantry hoisting with switch control in cab.

SAFETY

Load Moment Indicator System

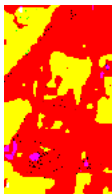

An easy-to-read LCD display is installed with the overload prevention mechanism, indicating rated and actual loads and other useful data. The smooth-stop device for boom lowering prevents dangerous swaying of the load due to sudden automatic stops.

Function Lock Lever

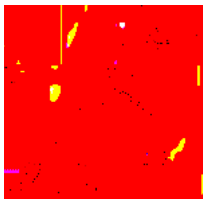

Function lock lever prevents accidental operation when the operator enters or leaves the cab.

Key-Controlled Release Switches

Safety enhancing mechanisms can be individually engaged or cancelled for specific operational needs by using these keys such as free-fall operation and safety function. These keys can be kept by safety officer to prevent any human-error.



Optional Free-Fall Control Switches

The free-fall control switches, strategically located on the hoist levers, allow the operator to engage free-fall whenever desired without removing his hands from the control levers.

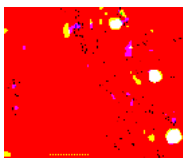

Swing Flashers

Swing flashers and a warning buzzer alert in vicinity when the machine is swinging.

SIMPLIFIED MAINTENANCE

Multi-Display



The easy-to-read LCD multi-display provides current status information on such functions as engine rpm, maintenance and on-board trouble-shooting, providing the operator with an

ongoing real-time assessment of the machine's conditions at a glance.

Easy Maintenance

A new engine layout on the side of the machine provides easy access for routine inspections and servicing.



STANDARD EQUIPMENT

Main Machine

- Boom hoist pedal • Air conditioner

Safety Device

- Drum safety pawl • Boom backstops
- Boom over hoist auto-stop device
- Hook over hoist auto-stop device
- Swing lock pin • Signal horn
- Overload alarm lamp • Cab top guard
- Fire extinguisher

Transportation

- Retractable crawlers
- Counterweight self-removal
- Gantry cylinder

Others

- Electric fuel pump • Tool kits
- Operator's manual

OPTIONAL EQUIPMENT

Main Machine

- Free-fall function for main and aux. winch
- Third drum
- Hydraulic tagline
- Electric fan
- Foot throttle
- One way call
- Drum rotation indicators (front and rear drum)
- Service platform for machine room

Attachment

- Insert boom • Hook
- Auxiliary sheave • Fixed jib



Note: This catalog may contain photographs of machines with specifications, attachments and optional equipment not certified for operation in your country. Please consult KOBELCO for those items you may require. Due to our policy of continual product improvements all designs and specifications are subject to change without advance notice.

Copyright by KOBELCO CRANES CO., LTD. No part of this catalog may be reproduced in any manner without notice.



KOBELCO CRANES CO., LTD.

17-1, Higashigotanda 2-chome, Shinagawa-ku, Tokyo, 141-8626 JAPAN
Tel: ++81 (0) 3-5789-2130 Fax: ++81 (0) 3-5789-3372

Inquiries To: