

KOMATSU®

BR380JG-1E0

HORSEPOWER
Gross: 149 kW 200 HP @ 2050 rpm
Net: 140 kW 187 HP @ 2050 rpm

OPERATING WEIGHT
34000 kg 74,960 lb

ecot3

BR
380
JG



MOBILE CRUSHER

Photo may include optional equipment.

WALK-AROUND

The newly designed Komatsu BR380JG-1E0 mobile crusher looks simple but is very powerful.

The upgraded Komatsu designed crusher offers you amazing production capacity of **50 – 240 ton/h** (55 – 265 U.S. ton/h).

Newly designed vibrating grizzly feeder

The vibrating grizzly feeder moves the material elliptically, so the material can be effectively separated and evenly fed into the jaw.

HydraMind hydraulics and all-hydraulic drive system

Fully hydraulic drive system gets you working right away. The HydraMind system supplies the optimal amount of oil through load-sensing and pressure-compensated valves. Optional equipment can be connected at the hydraulic outlets on the chassis (option).

Large-capacity hopper

The **2500 mm 8'2" x 3770 mm 12'4"** feedhopper is accessible from three sides for material loading.

High-performance jaw

The KCJ4222 large-capacity jaw crusher guarantees maximum crushing capacity in this class along with ease of maintenance. In addition, Komatsu's locking cylinder mechanism allows you to change the discharge clearance with a simple one-touch adjustment and also facilitates the removal of clogged foreign material from the discharge side.



High-speed, large-capacity conveyor belt

A 1050 mm 42" (1000 mm 40") wide conveyor belt travels at 120 m 394' per minute. The discharge height is 2800 mm 9'2".

HORSEPOWER

Gross: 149 kW 200 HP @ 2050 rpm

Net: 140 kW 187 HP @ 2050 rpm

OPERATING WEIGHT

34000 kg 74,960 lb

SAA6D107E-1 turbocharged after-cooled diesel engine

provides 140 kW / 187 HP for superior crushing power. EPA Tier 3 and EU stage 3A emissions certified.

Emergency shut-off buttons are installed on both the left and right sides of the chassis, on the control panel, and on the remote control (option).

Sprinkler nozzles

and a **connector** are standard at the jaw entry.

Outstanding mobility

Hydraulic steering and high-travel speed make the machine easy to relocate. The BR380JG-1 uses the same track undercarriage as Komatsu's hydraulic excavators.

Hydraulic conveyor lifter in the up position ensures adequate ground clearance, and safe driving even on rough ground.

The mobile crusher uses a new interlock system that controls the travel operation, to prevent the conveyor from being dragged or colliding with the ground depending on the conveyor's position.

Photo may include optional equipment.

PRODUCTIVITY FEATURES



Equipped with an eco-friendly engine

Equipped with the SAA6D107E-1 engine, this new mobile crusher has a nominal output as high as 140 kW (187 HP). The latest KOMATSU engine technology for construction machinery, "ecot3", greatly reduces NOx emissions. This engine is EPA Tier 3 and EU Stage 3A emissions certified.

New Komatsu Jaw Crusher largest in its class

The large-capacity jaw crusher, KCJ4222, is another successful example of Komatsu's development efforts. Crushing efficiency is improved dramatically with the installation of a load-presetting semiautomatic feeder system and the increased crusher rotation speed.

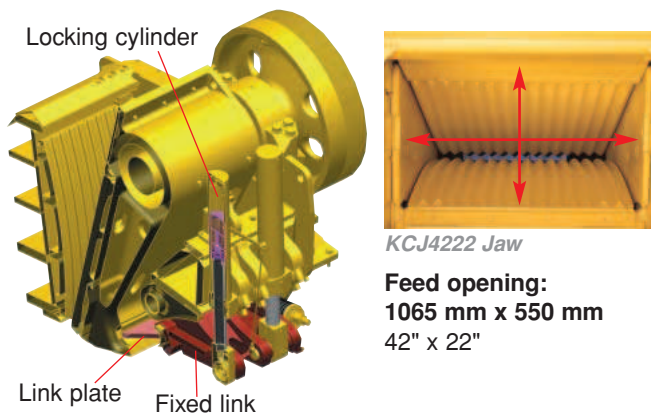

High-speed, large-capacity conveyor belt

The high discharge height of 2800 mm (9'2") makes it easy to configure a system with stock pile conveyor and screens. With its width of 1050 mm (42") and a belt speed of 120 m (394') /min., the belt conveyor has a high volume capacity. In addition, the conveyor reverse mode is provided to facilitate the removal of jammed foreign material.



The first hydraulic crusher protection mechanism in the world

Jaw crushers typically protect themselves by bending toggle plates when they are clogged or jammed with metal or wood debris. The KCJ4222 protects itself by allowing the locking cylinders to fully open the discharge port, which makes it easy to remove clogged foreign material from the crusher. (Patent pending)



Large production capacity

Komatsu's original large-capacity jaw crusher and the most advanced control systems have considerably increased its output capacity, making it easy to manage large workloads.

Fully automatic discharge setting adjustment system

The jaw crusher is equipped with an automatic discharge setting adjustment system that makes it easy to change the opening of the discharge port. Even as both of the jaw plates or one wear, you can adjust the discharge setting with a simple one-touch operation (adjustable within several minutes) with this automatic system. On the monitor panel, you can choose one of the three adjustment modes. (Patent pending)

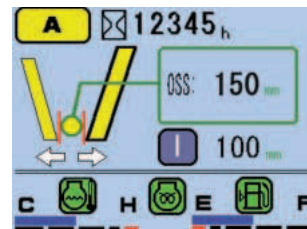

- Mode A: Input a desired value for the discharge setting.
- Mode B: Increase or decrease the current discharge setting.
- Mode C: Press the manual switch to increase or decrease the present discharge setting.

High mobility

The conveyor elevation system insures a high minimum ground clearance, which provides the crusher with outstanding maneuverability at any crushing site. In addition, improved configuration location of the guide handle makes it much easier to operate the conveyor lifter.

The mobile crusher uses a new interlock system that controls the travel operation, to prevent the conveyor from being dragged or colliding with the ground depending on the conveyor's position.



- Minimum ground clearance
- Traveling: 200/300 mm (7.9"/12")
- Crushing: 100/200 mm (3.9"/7.9")

* "Traveling" is prohibited by interlock when the ground clearance is 100mm (3.9").

EASY MAINTENANCE AND SAFETY

Maximum reliability and minimal maintenance

In addition to the spacious clearance of 530 mm (1'9") between the jaw crusher and the conveyor belt, the crusher's bottom area is sealed with covers. This construction design prevents re-bar from being caught by the crusher's member structure. Wide openings on the side frames also ensure easy access to the space below the crusher to remove clogged foreign material.



Opening In The Engine Side



Opening In The Crusher Side
(both sides of undercarriage)

Comfortable design

- To prevent dust, sprinkler nozzles are provided as a standard attachment at the top of the jaw crusher (the water tank & spraying system is option).



Sprinkler Nozzle

Safety

- **Slip-resistant plates**
Highly durable slip-resistant plates maintain superior traction.
- **Thermal and fan guard**
Thermal and fan guards are placed around high-temperature parts of the engine and fan drive.

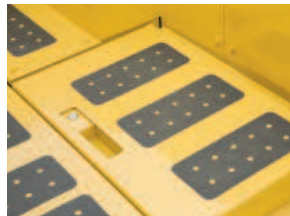

Ease of operation

- All the switches necessary for operation are located on the main control panel, making it easier for the operator standing on the ground to reach and safely control the operation. As the control system is equipped with the one-touch start feature, all you have to do is press the start switch. This simple operation will sequentially start the operation of the magnetic separator, belt conveyor, jaw crusher and feeder.



Main Control Panel

- The multi-function monitor displays the status of all components in real time. With this monitor, you can easily identify the location of a problem.

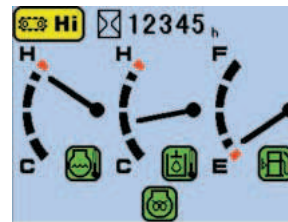

Traveling Mode

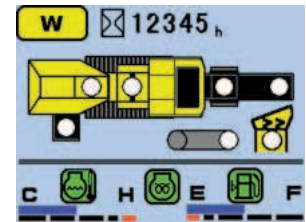

Crushing Mode

- **Radio remote controller (Option)**
With this controller, you can change the mode between "Travel" and "Operation", while remaining onboard the excavator. You can also use it to operate the one-touch start feature.



Photo may include optional equipment.

SPECIFICATIONS



ENGINE

ModelKomatsu SAA6D107E-1
 Type4-cycle, water-cooled, direct injection
 AspirationTurbocharged and air to air aftercooled
 Number of cylinders6
 Bore**107 mm** 4.21"
 Stroke**124 mm** 4.88"
 Piston displacement**6.69 ltr** 408 in³
 Horsepower
 SAE J1995Gross **149 kW** 200 HP
 ISO 9249/SAE J1349Net **140 kW** 187 HP
 Rated rpm2050 rpm
 GovernorAll-speed, electrical
 EPA Tier 3 and EU Stage 3A emissions certified.



HYDRAULIC SYSTEM

TypeHydraMind (Hydraulic Mechanical Intelligence New Design) system
 Closed-center system with load-sensing and pressure-compensated valves
 Main pump:
 TypeVariable-displacement piston pumps
 Pump for hydraulic system
 Travel, crusher, feeder, conveyor and 4 equipment options
 Maximum flow**2 x 230 ltr/min** 2 x 60.8 U.S. gal/min
 Maximum pressure**37.3 MPa** 380 kg/cm² 5,400 psi
 Maximum travel speed**3 km/h** 1.9 mph
 System oil flow (travel, crusher, feeder, conveyor, and option):
 Travel**2 x 160 ltr/min** 2 x 42.3 U.S. gal/min
 Crusher**230 ltr/min** 60.8 U.S. gal/min
 Feeder**.58 ltr/min** 15.3 U.S. gal/min
 Conveyor**.38 ltr/min** 10.0 U.S. gal/min
 Option**.28 ltr/min** 7.4 U.S. gal/min



OPERATING WEIGHT

Operating weight, including 500 mm shoes**34000 kg** 74,960 lb



UNDERCARRIAGE

Seal of trackSealed track
 Track adjusterHydraulic
 Number of shoes45 each side
 Number of carrier rollers2 each side
 Number of track rollers5 each side



CRUSHER

JawKomatsu KCJ4222
 Inlet size**1065 mm x 550 mm** 42" x 22"
 Discharge setting (O.S.)**50 mm to 150 mm** 2.0" to 5.9"
 Rotating speed (variable)170 – 330 rpm

Production Capacity

Maximum treatment capacity (with a muck content of 30%). Unit: **ton/h** U.S. ton/h

Material	Crusher Discharge Setting (open side)			
	50 mm 2.0"	80 mm 3.1"	120 mm 4.7"	150 mm 5.9"
Natural stone	50 – 70 55 – 77	80 – 115 88 – 127	125 – 180 138 – 198	170 – 240 187 – 265
Concrete debris	60 – 85 66 – 94	90 – 130 99 – 143	125 – 175 138 – 193	— —

Note: The production capacity is the sum of the quantity of the material crushed by the crusher and the quantity of the material that passed through the grizzly bar. It depends on the type and properties of the material and the working conditions.



GRIZZLY FEEDER

FrequencyMaximum 1100 cpm
 Size**1000 mm x 3070 mm** 3'3" x 10'1"
 Amplitude (not loaded, all amplitude)**8.0 mm** 0.3"
 Drive typeDirect drive with hydraulic motor



COOLANT AND LUBRICANT CAPACITY

Fuel tank**400 ltr** 105.7 U.S. gal
 Radiator**.28 ltr** 7.4 U.S. gal
 Engine**.26 ltr** 6.9 U.S. gal
 Final drive, each side**4.5 ltr** 1.2 U.S. gal
 Hydraulic system**209 ltr** 55.2 U.S. gal



DIMENSIONS

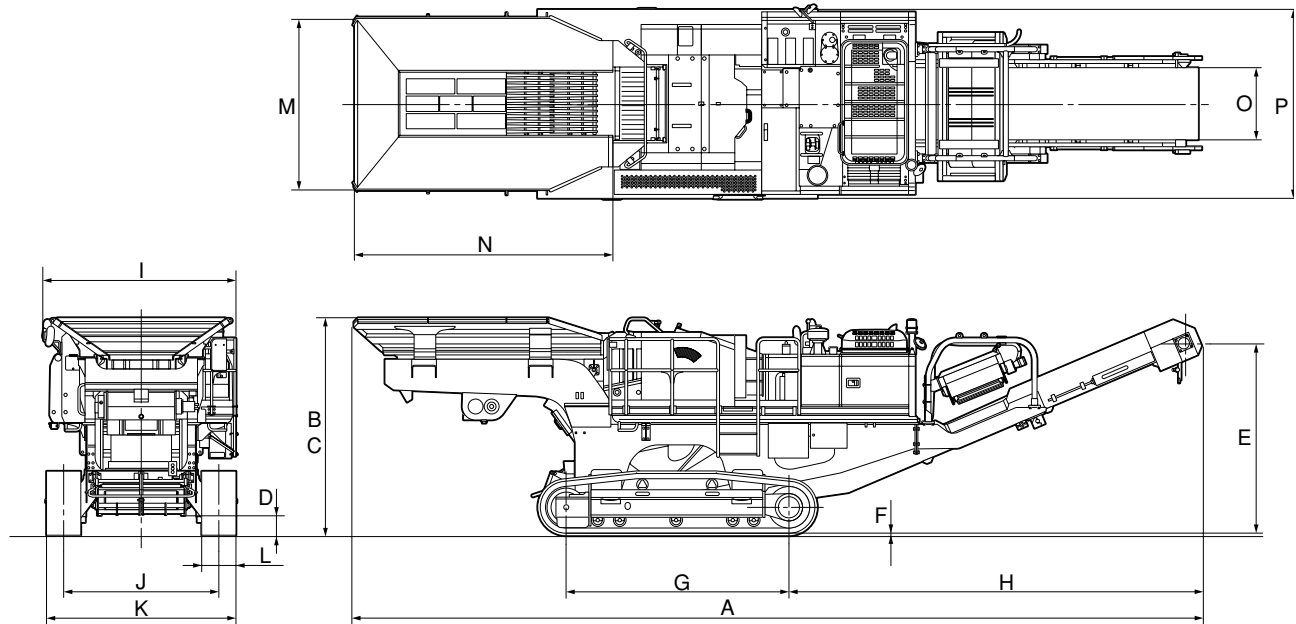

A	Overall length	12500 mm	41'
B	Overall height	3200 mm	10'6"
C	Feed height—side	3200 mm	10'6"
D	Minimum ground clearance (traveling)	300 mm	12"
E	Discharge height	2800 mm	9'2"
F	Grouser height	26 mm	1"
G	Length of track on ground	3275 mm	10'9"
H	Discharge from final drive center	6080 mm	19'11"

I	Overall width	2870 mm	9'5"
J	Track gauge	2280 mm	7'6"
K	Track width	2780 mm	9'1"
L	Shoe width	500 mm	20"
M	Hopper width	2500 mm	8'2"
N	Hopper length	3770 mm	12'4"
O	Discharge conveyor belt width	1050 mm	3'5"
P	Transport width	2810 mm	9'3"



STANDARD EQUIPMENT

- Alternator, **35 ampere** 24 V
- Automatic deaeration system for fuel line
- Automatic engine warm-up system
- Dry type air cleaner, double element
- Electric horn
- EMMS monitoring system
- Engine, Komatsu SAA6D107E-1
- Engine overheat prevention system
- Fan guard structure
- Hydraulic track adjusters (each side)
- Multi-function color monitor
- Power maximizing system
- PPC hydraulic control system
- Radiator and oil cooler dust proof net
- Rearview mirror, LH
- Shoes, triple grouser: **500 mm** 20"
- Slip-resistant plates
- Starting motor, **5.5 kW** 24 V x 1
- Travel alarm



OPTIONAL EQUIPMENT

- Batteries, large capacity
- Conveyor protective plate
- Torque up pulley
- **MAGNETIC SEPARATOR:**
- **MUCK CONVEYOR:**
- **WATER TANK & SPRAYING SYSTEM:**
- **RADIO REMOTE CONTROLLER:**

Magnetic separator for primary conveyor, **900 mm** 35" wide



Muck conveyor assembly can be folded by hydraulic cylinder, **3000 mm x 500 mm** 9'10" x 1'8"



WATER TANK & SPRAYING SYSTEM:



RADIO REMOTE CONTROLLER:



Function:

- Travel
Left/Right
Forward/Reverse
- Feeder
On/Off
- Work equipment
Start/Stop
- Mode selection
Operation/Travel

www.Komatsu.com

Printed in Japan 201306 IP.SIN

KOMATSU[®]

CEN00175-04

Materials and specifications are subject to change without notice
KOMATSU is a trademark of Komatsu Ltd. Japan