

KOMATSU®

D155A-6

D
155A

HORSEPOWER

Gross: 268 kW 360 HP / 1900 min⁻¹

Net: 264 kW 354 HP / 1900 min⁻¹

OPERATING WEIGHT

41700 kg

BLADE CAPACITY (ISO 9246)

Semi-U DOZER: 9.4 m³



Photo may include optional equipment.

WALK-AROUND





PRODUCTIVITY

- Komatsu Technology
- Fuel-efficient Electronic Controlled Engine
- Hydraulic Driven Engine Cooling Fan
- Automatic/Manual Gearshift Selectable Mode

COMFORT

- New Integrated ROPS (ISO 3471) Cab
- Comfortable Ride with Cab Damper Mounting
- Gearshift Pattern Preset Function
- Fuel Control Dial

* Information and Communication Technology

ICT* & KOMTRAX

- Large Multi-lingual High Resolution Liquid Crystal Display (LCD) Monitor
- KOMTRAX

WORK EQUIPMENT

- Innovative SIGMADOZER
- Newly Designed Ripper

MAINTENANCE

- Easy Radiator Cleaning with Hydraulic Drive Fan
- Oil Pressure Checking Ports
- Gull-wing Engine Side Covers
- Measures Against Poor Quality Fuel
- Dust-proof Measures

HORSEPOWER

Gross: 268 kW 360 HP / 1900 min⁻¹
 Net: 264 kW 354 HP / 1900 min⁻¹

OPERATING WEIGHT

41700 kg

BLADE CAPACITY (ISO 9246)

Semi-U DOZER: 9.4 m³

PRODUCTIVITY FEATURES



Komatsu Technology

Komatsu develops and produces all major components, such as engines, electronics and hydraulic components, in house. With this “Komatsu Technology” and adding customer feedback, Komatsu is achieving great advancements in technology. To achieve both high levels of productivity and economical performance, Komatsu has developed the main components with a total control system. The result is a new generation of high performance and environment-friendly bulldozers.

Fuel-efficient Electronic Controlled Engine

The Komatsu SAA6D140E-5 engine delivers 264 kW 354 HP at 1900 min⁻¹. The fuel-efficient, powerful Komatsu engine makes the D155A-6 superior in both ripping and dozing operations. The engine is U.S. EPA Tier 2 and EU Stage 2 emissions equivalent, and features direct fuel injection, turbo-charger and air-to-air charged air cooler to maximize power. To minimize noise and vibration, the engine is mounted to the main frame with rubber cushions.

Hydraulic Driven Engine Cooling Fan

Fan rotation is automatically controlled depending on coolant and hydraulic oil temperature, saving fuel consumption and providing great productivity with a quiet operating environment.

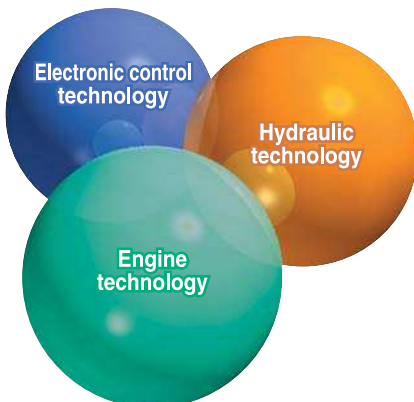
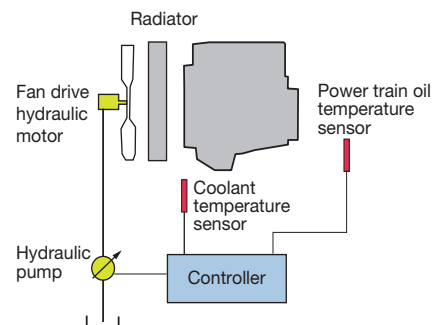

Automatic/Manual Gearshift Selectable Mode

Automatic or manual gearshift modes can be selected with ease to suit the work at hand by simply pressing the switch on the LCD monitor (Selection at neutral).

Automatic gearshift mode

The mode for general dozing. When a load is applied, the gear automatically shifts down, and when the load is off, it automatically shifts up to a set maximum gear speed. This mode automatically selects the optimum gear speed.

Manual gearshift mode

The mode for dozing and ripping rough ground. When loaded, the gear automatically shifts down, but does not shift up when the load is off.



Field-proven Low-drive, Rigid Type Undercarriage

Komatsu's unique low-drive undercarriage features less shoe slippage compared with other types of undercarriage. The undercarriage follows the ground firmly for increased drawbar pull. Large strengthened shoes have been proven to be highly durable in various job sites all over the world.

Length of track on ground: 3150 mm

Automatic Transmission with Torque Converter

Greater power train efficiency is achieved by the new automatic gearshift transmission. The automatic gearshift transmission selects the optimal gear range depending on the working conditions and load placed on the machine. This means the machine is always operating at maximum efficiency (Manual gearshift mode is selectable with a switch).



COMFORT



New Integrated ROPS (ISO 3471) Cab

A newly designed cab is integrated with ROPS (ISO 3471). High rigidity and superb sealing performance sharply reduce noise and vibration for the operator and helps prevent dust from entering the cab. The result is relaxed operation in a comfortable environment for the operator. In addition, side visibility is increased because external ROPS structure and posts are not required. Outstanding visibility has been achieved.



Comfortable Ride with Cab Damper Mounting

The D155A-6's cab mount uses a cab damper which provides excellent shock and vibration absorption capacity with its long stroke. Cab damper mounts soften shocks and vibration while traveling over adverse conditions, which conventional mounting systems are unable to absorb. The cab damper spring isolates the cab from the machine body, suppressing vibration and providing a quiet, comfortable operating environment.

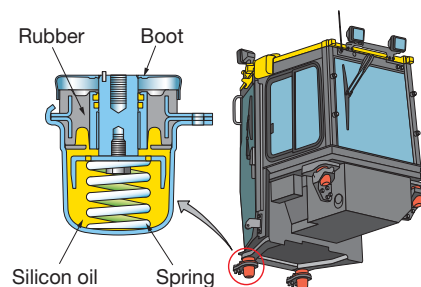

Automatic Air Conditioner (A/C) (Optional)

Enables you to easily and precisely set cab atmosphere with the instruments on the large LCD monitor. The bi-level control function keeps the operator's head and feet cool and warm respectively. This improved air flow function keeps the inside of the cab comfortable throughout the year. Defroster function keeps front glass clear.



Pressurized Cab

Optional air conditioner, air filter and a higher internal air pressure minimize external dust from entering the cab.

Human-machine Interface Palm Command Control System (PCCS)

Komatsu's ergonomically designed control system "PCCS" creates an operating environment with "complete operator control".

Palm Command Electronic Controlled Travel Control Joystick

Palm command travel joystick provides the operator with a relaxed posture and superb fine control. Transmission gear shifting is simplified with thumb push buttons.

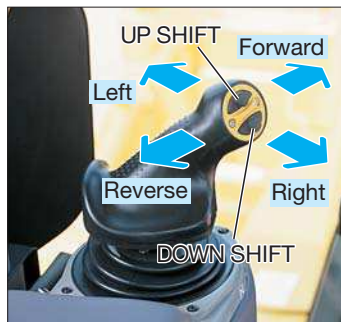

Palm Command Pressure Proportional Control (PPC) Controlled Blade/Ripper Control Joystick

Blade control joystick uses a PPC valve and blade control joystick ergonomics are similar to the travel control joystick. PPC control combined with the highly reliable Komatsu hydraulic system enables superb fine control.

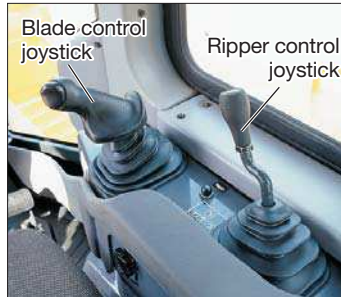

Gearshift Pattern Preset Function

When the gearshift pattern is set to either <F1-R2>, <F2-R2> or <F2-R3L> in automatic gearshift mode, the gear is automatically shifted, reducing round trip repetition work time and operator's efforts.

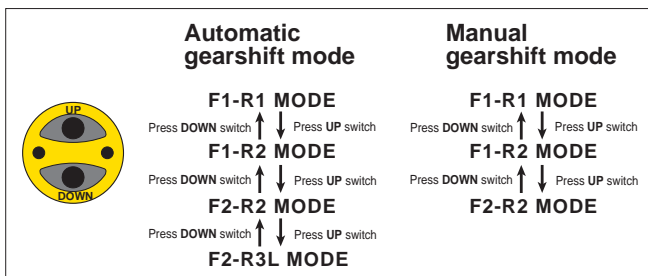

Fuel Control Dial

Engine revolution is controlled by an electronic signal, providing ease of operation, eliminating maintenance of linkage and joints.



Height Adjustable Armrest (Optional)

Armrest is height adjustable without any tools, providing the operator with firm arm support.

Electronic Controlled Modulation Valve (ECMV) Controlled Transmission and Brakes

Controller automatically adjusts each clutch engagement depending on travel conditions, providing smooth shockless clutch engagement, improved component life and operator ride comfort.

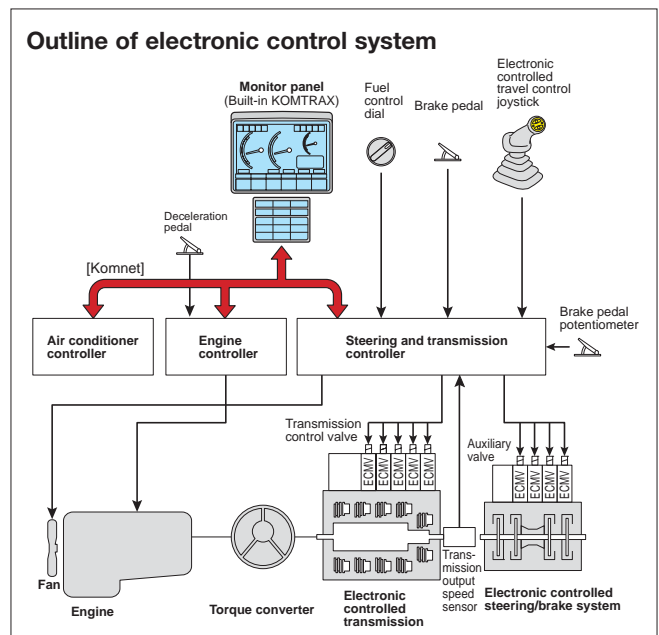



Large Multi-lingual High Resolution LCD Monitor

A large user-friendly high resolution LCD color monitor enables safe, accurate and smooth work. Visibility and resolution are further improved compared with current 7-inch large LCD. Simple and easy to operate switches. Function keys facilitate multi-function operations. Displays data in 10 languages to globally support operators around the world.

Indicators

- 1 Message monitor
- 2 Operation mode monitor
- 3 A/C monitor
- 4 Engine pre-heating monitor
- 5 Fan reverse monitor
- 6 Service meter readings
- 7 Reverse slow mode monitor
- 8 Engine coolant temperature gauge
- 9 Multi-gauge
- 10 Fuel gauge
- 11 Travel speed range display
- 12 Gear shift mode display
- 13 Speed range display
- 14 ECO indicator

Basic operation switches

- 1 Operating mode selector switch
- 2 Gear shift mode selector switch
- 3 Customize switch
- 4 Buzzer cancel switch
- 5 Function switches

Equipment Management Monitoring System

Troubleshooting function to keep operator informed

Various meters, gauges, and warning functions are centrally arranged on the LCD monitor. Offers ease of start-up inspection and promptly warns the operator with a lamp and buzzer if any abnormalities should occur. In addition, countermeasures are indicated in 4 stage error codes. Replacement times for oil and filters are also indicated.



Electric dust indicator

Electric dust indicator allows the monitor to display the caution icon for the air cleaner clogging on the screen to inform the operator sitting on the seat of the air cleaner clogging status.



Maintenance function

The monitor informs replacement time of oil and filters on the LCD when the replacement interval is reached.



Trouble data memory function

Monitor stores abnormalities for effective troubleshooting.



Assists Customer's Equipment Management and Contributes to Fuel Cost Cutting

Equipment Management Support

KOMTRAX terminal installed on your machine collects and sends information such as machine location, working record, machine conditions, etc. using wireless communication. You can review the KOMTRAX data remotely via the online application. KOMTRAX not only gives you the informations on your machine, but also the convenience of managing your fleet on the Web.



Machine location



Historical location check

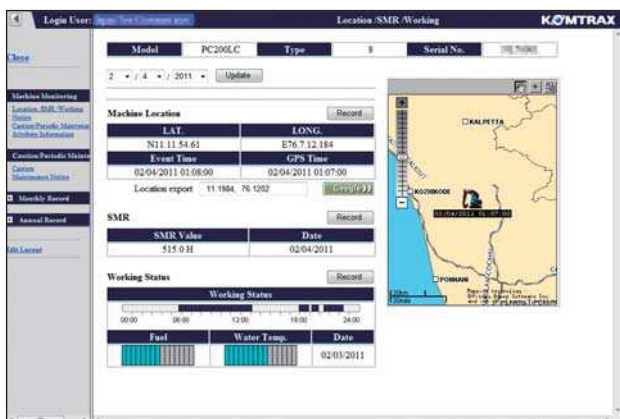

Operation management

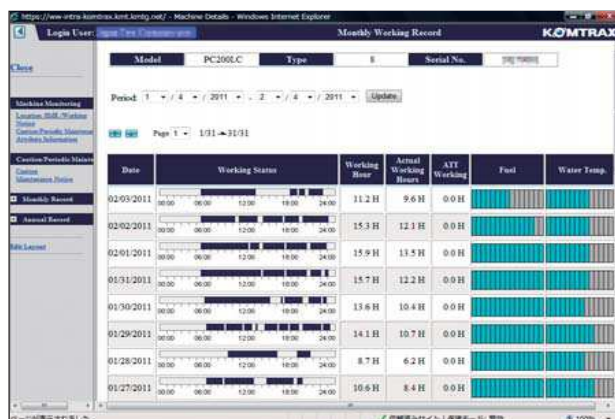

Monthly operation summary

Blade

Innovative SIGMADOZER

Based on a completely new digging theory, SIGMADOZER dramatically improves dozing performance and increases productivity. A new frontal design concept adopted for digging and rolling up at the center of the blade increases soil holding capacity, simultaneously reducing sideway spillage. Reduced digging resistance produces smoother flow of earth, enabling the dozing of larger quantities of soil with less power. In addition, adoption of a new blade linkage system holds the blade closer to the tractor for improved visibility, enhanced digging force and reduced lateral sway of the blade. This is the new generation blade.

Production increased by 15%

Compared with our conventional model

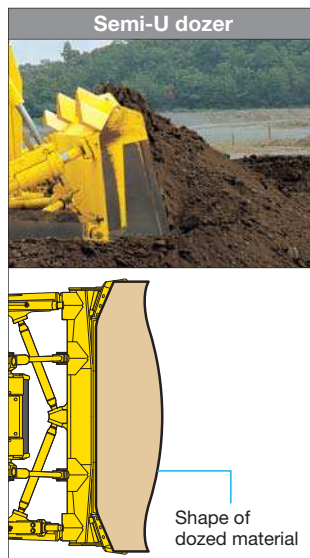
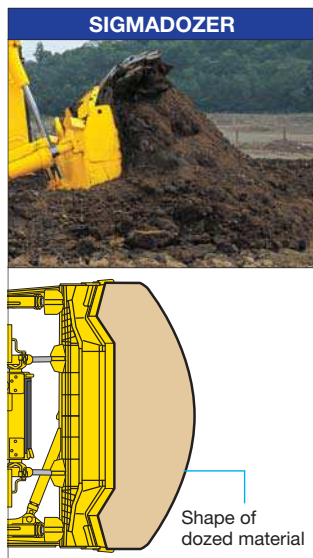

Ripper

Ripper performance

Ripper cylinders are reduced from four to two, greatly improving rear visibility during ripping. Also, expanded ripper movement offers a wider range of operation.

Newly designed ripper

D155A-6

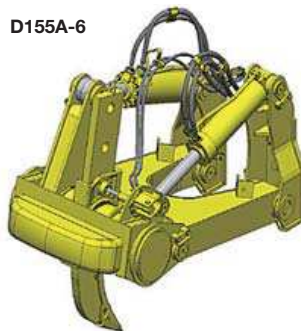

D155A-2

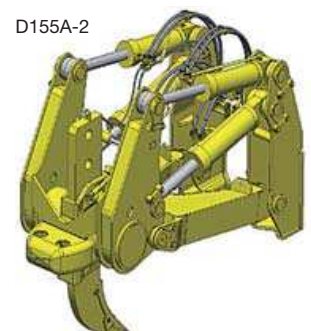

Ripping reach

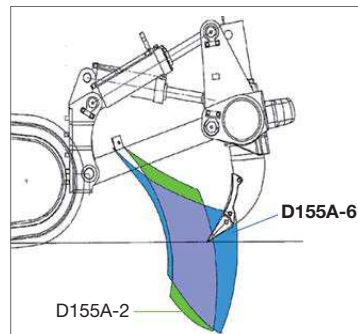

D155A-6 rear visibility

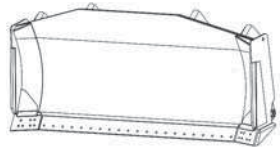
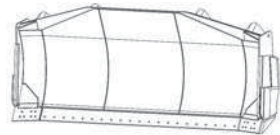
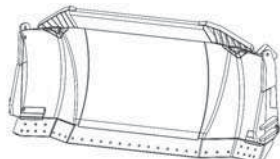
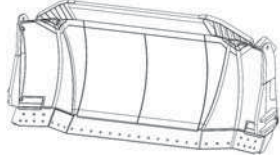
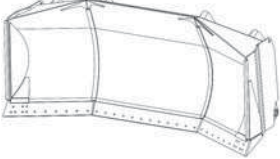
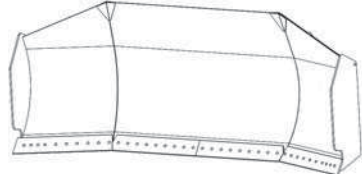

Blade

Type	Feature	Image
Semi-U Dozer	The blade combines penetration ability of straight blade with increased load capacity provided by short wings which include only the end bits.	
Strengthened Semi-U Dozer		
SIGMADOZER	A new frontal design concept adopted for digging and rolling up at the center of the blade increases soil holding capacity, simultaneously reducing sideways spillage. Reduced digging resistance produces smoother flow of earth, enabling the dozing of large quantities of soil with less power.	
Strengthened SIGMADOZER		
U Dozer	The wings on this blade minimize material spillage. Since this blade has a lower HP/loose cubic yards than a straight-tilt dozer, this blade is suitable for moving lighter or loose materials over long distances. Suitable works are land reclamation, stockpiling and other similar jobs.	
Coal Dozer	Specialized blade for pushing coal, with larger width and deep angled wings.	

Ripper

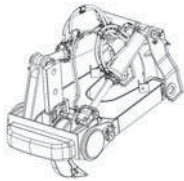
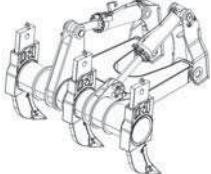
Type	Feature	Image
Variable Giant Ripper	Specially made to handle hard rock with reinforced beam and a shank. The tilt angle of the ripper point is adjustable for better penetration and fragmentation.	
Variable Multi-shank Ripper	The ripper point angle can be varied hydraulically to suit the specific ground conditions. The ideal movement of ripper points ensures powerful digging force throughout the entire digging angle range.	

MAINTENANCE

Easy Radiator Cleaning with Hydraulic Drive Fan

The radiator can be cleaned by utilization of the reversible, hydraulically driven cooling fan. The fan can be reversed from inside the cab by simply turning the switch to reverse.

Oil Pressure Checking Ports

Pressure checking ports for power train components are centralized to promote quick and simple diagnosis.



Gull-wing Engine Side Covers

The opening area is further enlarged when gull-wing engine side covers are opened, facilitating engine maintenance and filter replacement. Side covers have been changed to a thick one-piece structure with a bolt-on catch to improve durability.



Reliable Simple Hull Frame

Simple hull structure main frame design increases durability and reduces stress concentration at critical areas. The mono-coque track frame has a large cross section and utilizes pivot shaft mounting for greater reliability.

Sealed Connectors

Main harnesses and controller connectors are equipped with sealed connectors providing high reliability, as well as water and dust resistance.

Flat Face O-ring Seals

Flat face O-ring seals are used to securely seal all hydraulic hose connections and to help prevent oil leakage.

Measures Against Poor Quality Fuel

In order to help protect the engine against dust and water contained in the fuel, the machine is equipped with a new high efficient main fuel filter and a large water separator. In addition, fuel tank drain valve, water drain valve of the water separator and fuel drain valve are concentrated at one place.



Large water separator

Enclosed Hydraulic Piping

Hydraulic piping for the blade tilt cylinder is completely housed in the push arm, helping protect it from damage.

Modular Power Train Design

Power train components are sealed in a modular design, making servicing work clean, smooth and easy.

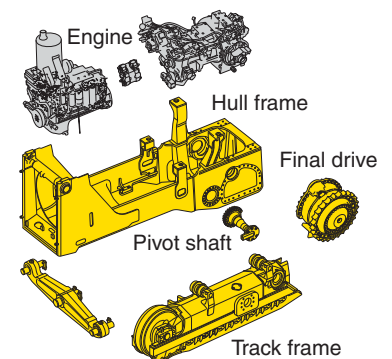

Disc Brakes

Wet disc brakes require less maintenance.

Dust-proof Measures

Large fresh air pre-cleaner is also provided as optional equipment. The hydraulic tank and the fuel tank are equipped with a high-filtration breather with pressure valve to help prevent dust from entering.



Large fresh air pre-cleaner



High-filtration breather

KOMATSU TOTAL SUPPORT**Komatsu Total Support**

To keep your machine available and minimize operation cost when you need it, Komatsu Distributor is ready to provide variety of support before and after procuring the machine.

Fleet recommendation

Komatsu Distributor can study customer job site and provide the most optimum fleet recommendation with detailed information to meet all of your application needs when you are considering to buy new machines or to replace the existing ones from Komatsu.

**Product support**

Komatsu Distributor secure the certain quality of machine will be delivered.

Parts availability

Komatsu Distributor is available for emergency inquiry by the customers for genuine, quality guaranteed Komatsu parts.

Technical support

Komatsu product support service (Technical support) are designed to help customer. Komatsu Distributor offers a variety of effective services how much Komatsu is dedicated to the maintenance and support of Komatsu machine.

- Preventive Maintenance (PM) clinic
- Oil & Wear analysis program
- Undercarriage inspection service, etc.

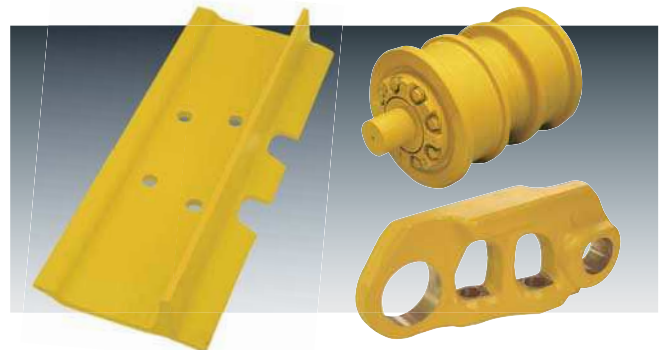
**Repair & maintenance service**

Komatsu Distributor offers quality repair service, periodical maintenance, and maintenance service to the customer, utilizing and promoting Komatsu developed programs.

Komatsu Reman (Remanufacturing) components

Komatsu Reman products are the result of the implementation of the Komatsu global Reman policy which establishes and agrees to reduce the owning, operating and total Life Cycle Costs (LCC) to Komatsu's customer through prompt delivery, high quality and competitively priced in own remanufactured products.



SPECIFICATIONS



ENGINE

Model Komatsu SAA6D140E-5
 Type 4-cycle, water-cooled, direct injection
 Aspiration Turbocharged, air-to-air charged air cooler
 Number of cylinders 6
 Bore x stroke 140 mm x 165 mm
 Piston displacement 15.24 L
 Governor All-speed and mid-range, electronic
 Horsepower
 SAE J1995 Gross 268 kW 360 HP
 ISO 9249 / SAE J1349* Net 264 kW 354 HP
 * Net horsepower at the maximum speed of
 radiator cooling fan Net 239 kW 320 HP
 Rated rpm 1900 min⁻¹
 Fan drive type Hydraulic
 Lubrication system
 Method Gear pump, force lubrication
 Filter Full-flow
 U.S. EPA Tier 2 and EU Stage 2 emissions equivalent.



TORQFLOW TRANSMISSION

Komatsu's automatic TORQFLOW transmission consists of a water-cooled, 3-element, 1-stage, 1-phase torque converter, and a planetary gear, multiple-disc clutch transmission which is hydraulically actuated and force-lubricated for optimum heat dissipation. Gearshift lock lever and neutral switch prevent machine from accidental starts.

Travel speed	Forward	Reverse
1st	3.9 km/h	4.7 km/h
2nd	5.7 km/h	6.8 km/h
3rd L	7.5 km/h	9.2 km/h
3rd	11.4 km/h	13.7 km/h

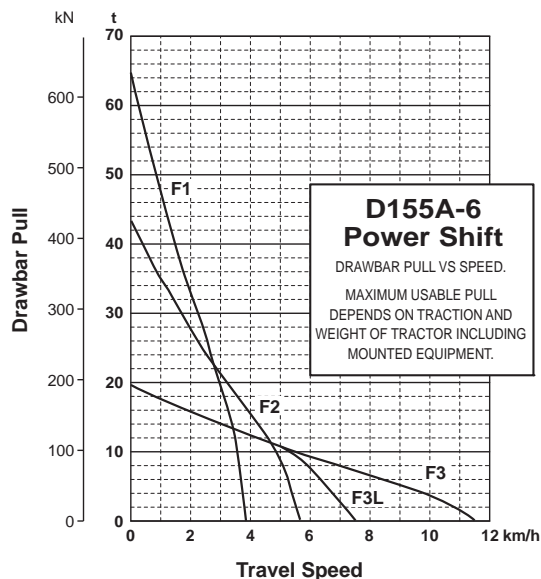

FINAL DRIVES

Double-reduction, spur and planetary final drives increase tractive effort. Segmented sprockets are bolt-on for easy in-the-field replacement.



STEERING SYSTEM

Palm Command Control System (PCCS) controls for all directional movements. Pushing the PCCS joystick forward results in forward machine travel, while pulling it rearward reverses the machine. Simply tilt the PCCS joystick to the left to make a left turn. Tilt it to the right for a right turn.

Wet, multiple-disc, pedal-controlled service brakes are spring-actuated and hydraulically released. Gearshift lock lever also applies parking brakes.

Minimum turning radius 2.14 m



UNDERCARRIAGE

Suspension Oscillation-type with equalizer bar and forward mounted pivot shafts

Track roller frame Monocoque, high-tensile-strength steel construction

Track shoes

Lubricated tracks. Unique dust seals for helping prevent entry of foreign abrasives into pin-to-bushing clearance for extended service. Track tension easily adjusted with grease gun.

Number of shoes (Each side) 41

Grouser height 80 mm

Shoe width (Standard/maximum) 560 mm/710 mm

Ground contact area 35280 cm²

Ground pressure (Tractor only) 90.2 kPa 0.92 kg/cm²

Number of track rollers (Each side) 7

Number of carrier rollers (Each side) 2



COOLANT AND LUBRICANT CAPACITY (REFILL)

Fuel tank 625 L

Coolant 82 L

Engine oil 37 L

Damper 1.5 L

Transmission, bevel gear

and steering system 90 L

Final drive (Each side) 31 L



OPERATING WEIGHT

Tractor weight 32300 kg
 Including rated capacity of lubricant, coolant, full fuel tank, operator and standard equipment

Operating weight 41700 kg
 Including Strengthened Semi U, giant ripper, cab, operator, standard equipment, rated capacity of lubricant, coolant, and full fuel tank.

Ground pressure 115.8 kPa 1.18 kg/cm²



DIMENSIONS

A	4130 mm
B	2140 mm
C	3510 mm
D	1790 mm
E	3150 mm
F	8680 mm
G	3100 mm
H	1370 mm
I	900 mm
J	3395 mm
K	590 mm

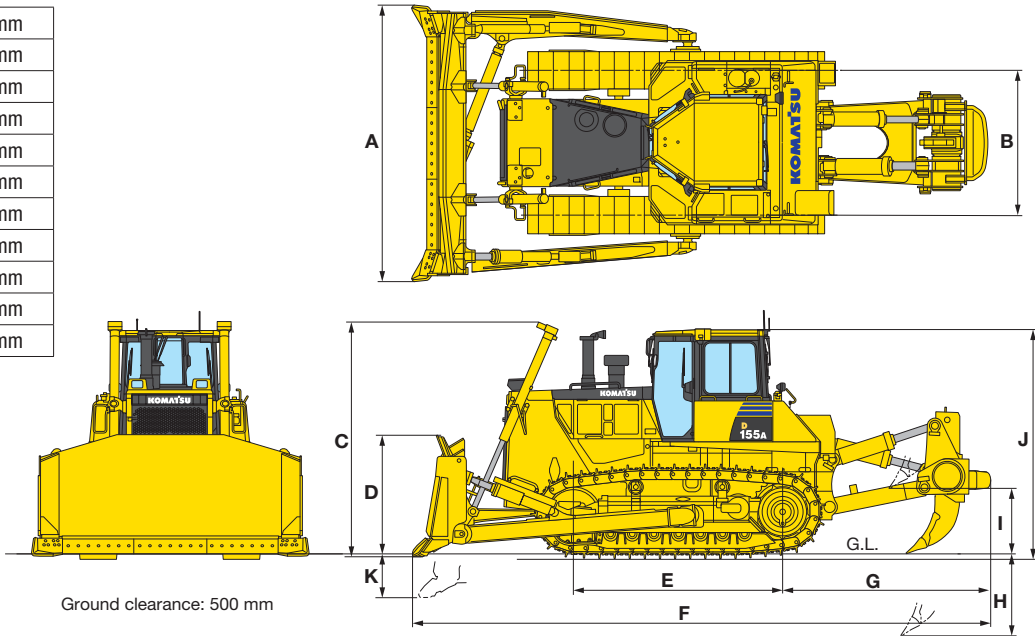

Ground clearance: 500 mm



HYDRAULIC SYSTEM

Closed-center Load Sensing System (CLSS) designed for precise and responsive control, and for efficient simultaneous operation.

Hydraulic control unit:

All spool control valves externally mounted beside the hydraulic tank. Variable piston pump with capacity (Discharge flow) of 200 L/min for implement at rated engine rpm.

Relief valve setting for implement 27.5 MPa 280 kg/cm²

Control valves:

Spool control valve for Semi-U tilt dozer and Full-U tilt dozer.

Positions: Blade lift Raise, hold, lower, and float
Blade tilt Right, hold, and left

Additional control valve required for variable digging angle multi-shank ripper and giant ripper.

Positions: Ripper lift Raise, hold, and lower and float
Ripper tilt Increase, hold, and decrease

Hydraulic cylinders Double-acting, piston

	Number of Cylinders	Bore
Blade Lift	2	110 mm
Blade Tilt	1	160 mm
Ripper Lift	1	180 mm
Ripper Tilt	1	200 mm

Hydraulic oil capacity (Refill):

Semi-U dozer 85 L
U dozer 85 L

Ripper equipment (Additional volume):

Multi-shank ripper 37 L
Giant ripper 37 L



DOZER EQUIPMENT

Use of high-tensile-strength steel in moldboard for strengthened blade construction. Blade tilt hose piping is mounted inside the dozer push arm to help prevent damage.

	Overall Length with Dozer	Blade Capacity (ISO 9246)	Blade Length x Height	Maximum Lift above Ground	Maximum Drop below Ground	Maximum Tilt Adjustment	Weight
Semi-U Dozer	6010 mm	9.4 m ³	4130 mm x 1790 mm	1250 mm	590 mm	950 mm	4960 kg
Strengthened Semi-U Dozer	6010 mm	9.4 m ³	4130 mm x 1790 mm	1250 mm	590 mm	950 mm	5620 kg
SIGMADOZER	6125 mm	9.4 m ³	4060 mm x 1850 mm	1320 mm	617 mm	920 mm	4940 kg
Strengthened SIGMADOZER	6125 mm	9.4 m ³	4060 mm x 1850 mm	1320 mm	617 mm	920 mm	5360 kg
U Dozer	6430 mm	11.9 m ³	4225 mm x 1790 mm	1250 mm	590 mm	970 mm	5630 kg
Coal Dozer	7005 mm	21.7 m ³	5310 mm x 2125 mm	1470 mm	530 mm	1000 mm	6075 kg
Angle Dozer	6580 mm	4.6 m ³	4850 mm x 1170 mm	1560 mm	660 mm	520 mm	5170 kg



STANDARD EQUIPMENT FOR BASE MACHINE

Engine and transmission

- Air cleaner, double element with dust indicator
- Blower cooling fan, hydraulic
- Decelerator pedal
- Engine, Komatsu SAA6D140E-5
- Muffler with rain cap
- Radiator with reserve tank
- TORQFLOW transmission

Electrical system

- Alternator, 24 V/60 A
- Batteries, 2 x 12 V/170 Ah
- Starting motor, 24 V/11 kW
- Working lights (Includes 2 front, 1 rear)

Hydraulic system

- Hydraulics for dozer
- Palm Command Control System (PCCS)

Guard and covers

- Fenders
- Rear cover
- Under guards, oil pan and transmission

Undercarriage

- 560 mm single grouser shoe
- Track roller guard, end sections
- Track shoe assembly
 - Sealed and lubricated track

Operator environment

- Large multi-lingual LCD color monitor
- Rear view mirror
- ROPS/FOPS Cab (ISO 3471/ISO 3449)
- Seat belt
- Suspension seat

Other equipment

- Backup alarm
- Horn, warning



OPTIONAL EQUIPMENT

Engine

- Large pre-cleaner

Electrical system

- Additional working lights
- Alternator, 75 A
- Alternator, 90 A
- Battery disconnect switch
- Large capacity batteries

Undercarriage

- Shoes

Shoes	Additional Weight	Ground Contact Area
560 mm Single-grouser	-0 kg	35280 cm ²
610 mm Single-grouser	+200 kg	38430 cm ²
660 mm Single-grouser	+410 kg	41580 cm ²
710 mm Single-grouser	+610 kg	44730 cm ²
560 mm Extreme Service Single-grouser	+450 kg	35280 cm ²
610 mm Extreme Service Single-grouser	+690 kg	38430 cm ²
660 mm Extreme Service Single-grouser	+920 kg	41580 cm ²

- Track roller full guard

Work equipment

- Blade
 - Angle dozer
 - Coal dozer
 - Full-U dozer
 - Semi-U dozer
 - SIGMADOZER
 - Strengthened semi-U dozer
 - Strengthened SIGMADOZER

- Rigid drawbar
- Variable giant ripper
 - Additional weight (Including hydraulic control unit): 3380 kg
 - Beam length: 1410 mm
 - Hydraulically-controlled parallelogram-type ripper with one shank. Digging angle infinitely adjustable. Standard digging angle: 45°
 - Maximum digging depth: 1370 mm
 - Maximum lift above ground: 900 mm

- Variable multi-shank ripper
 - Additional weight (Including hydraulic control unit): 3760 kg
 - Beam length: 2320 mm
 - Hydraulically-controlled parallelogram-type ripper with three shanks. Digging angle infinitely adjustable. Standard digging angle: 45°
 - Maximum digging depth: 900 mm
 - Maximum lift above ground: 900 mm

Operator environment

- Air conditioner (A/C)
- Cab heater and defroster

Other equipment

- Provision for aftermarket machine control system, TOPCON
- Rear view monitor system
- Tool kit

www.komatsu.com

Printed in Japan 201612 IP.As

KOMATSU®

CEN00255-07

Materials and specifications are subject to change without notice.
KOMATSU is a trademark of Komatsu Ltd. Japan.