

KOMATSU

D
155AX

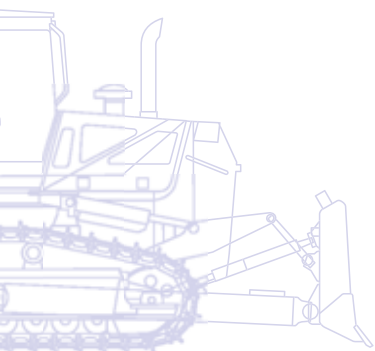

Crawler Dozer **D155AX-6**



ENGINE POWER
268 kW / 359 HP @ 1.900 rpm

OPERATING WEIGHT
39.500 kg

Courtesy of Machine.Market

Walk-Around

Remarkably efficient both for ripping and for dozing, the D155AX-6 is a productive, reliable and durable Komatsu bulldozer. Among many outstanding features, it boasts a powerful and fuel efficient power train, the Komatsu Sigmadozer® blade and a field proven automatic transmission and lockup torque converter electronically controlled with Komatsu's latest technology. The D155AX-6 is designed and built by Komatsu to give you a drastically enhanced competitive edge and a lower cost of ownership. Rain or shine, this Komatsu dozer will quickly become a trusted working partner.

High productivity & low fuel consumption

- Torque converter with auto lockup
- Automatic transmission
- Clean, powerful engine
- Selectable working modes
- Auto-downshift function

Optimized work equipment

- Sigmadozer® blade
- Semi-U and U blades
- Variable giant and multishank ripper
- Komatsu-Topcon blade control systems



D155AX-6

ENGINE POWER
268 kW / 359 HP @ 1.900 rpm

OPERATING WEIGHT
39.500 kg

First-class operator comfort

- Quiet and comfortable cab
- Fully adjustable air suspension seat
- Superior visibility on blade and ripper
- Less noise and vibrations



State of the art controls

- Hydrostatic steering system
- Gearshift preset function
- Easy and precise
- Large LCD colour multi monitor



Tough and reliable

- Low-drive undercarriage
- K-Bogie undercarriage system
- Sturdy, rugged design
- Highly reliable electric circuit

KOMTRAX

Komatsu Satellite
Monitoring System

High Productivity & Low Fuel Consumption

Torque converter with auto lockup

Combined with the automatic transmission, the exclusive automatic lock up torque converter on the D155AX-6 is the key to low cycle times and to improved overall performance. The power train control system either engages the torque converter when torque multiplication is needed, or automatically locks it up and sends full engine power directly to the transmission during less torque demanding applications. This eliminates unnecessary power loss and lets the machine constantly operate at maximum efficiency. Necessary drawbar pull is always maintained and overall fuel consumption is reduced by up to 10%.

Automatic transmission

Set by default, the D155AX-6's highly efficient transmission automatically matches the best gear mode for all dozing and ripping operations and includes a travel speed preset function to reduce work time and operator's efforts. Thanks to Komatsu's ECMV (Electronic Controlled Modulation Valves), gear changes are smoothly timed to always keep the power transfer at maximum efficiency.

A clean, powerful engine

A powerful and fuel-efficient engine certified for EU Stage IIIA and EPA Tier III emission regulations makes the D155AX-6 an outstanding performer both for dozing and ripping. This 268 kW / 359 HP ecot3 engine combines top productivity and preservation of the environment.

Hydraulic drive radiator cooling fan

The rotation speed of the cooling fan is electronically controlled and is correctly determined by the temperature of the engine coolant and hydraulic oil: the higher the temperature, the faster the fan will turn. This system increases fuel efficiency, reduces the operating noise levels and requires less horsepower than belt driven fans.

Selectable working modes

Working mode can be set to either "Power" for maximum power or to "Economy" for energy saving operations. Combined with a choice between automatic or manual working mode, this lets the operator select the optimum machine power configuration for the work at hand.



Komatsu SAA6D140E-5 ecot3 engine



Torque converter with auto lockup





Auto-downshift

The engine controller continuously monitors the engine speed, travel gear and travel speed. When a load is applied and the machine slows, the controller automatically downshifts, optimising the gear speed for the best dozing performance. This function enables comfortable operation and high productivity without manual downshifting. It can be deactivated by a cancel switch on the monitor panel.

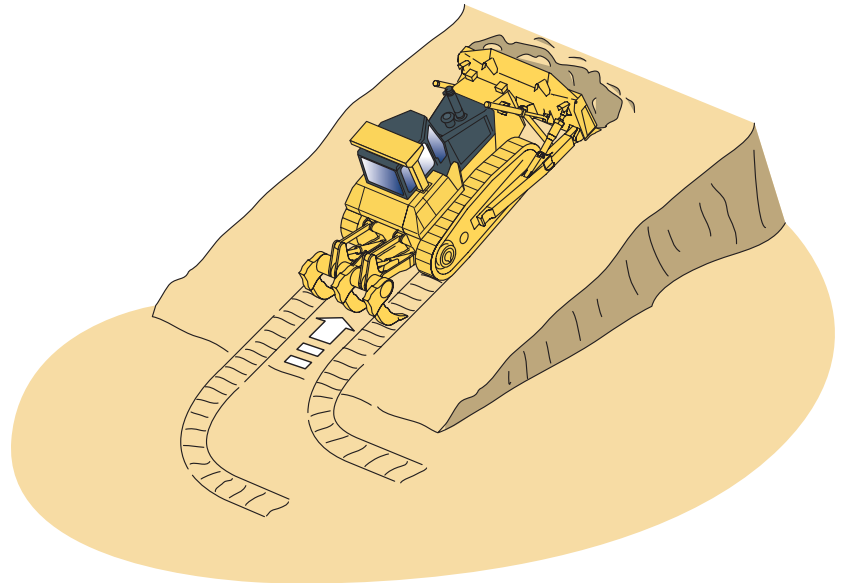

First-Class Operator Comfort

Quiet and comfortable cab

Operator comfort is essential for safe and productive work. The D155AX-6 provides a quiet and comfortable cab, the ideal environment to concentrate on the job at hand. The cab's hexagonal design and large tinted glass windows offer excellent panoramic visibility. The high capacity and fully automatic climate control system pressurizes the cab to keep dust out. A high quality sound absorbent lining covers the interior to minimize operator ear noise levels.

Fully adjustable suspension seat and travel control console

A comfortable, heavy-duty and fully adjustable suspension seat is at the centre of the operator's safe and cosy work space. For dozing operations, the seat faces straight forward, with a perfect view of both sides of the blade. For ripping, it can be turned 15° to the right, significantly improving rear visibility and reducing neck strain. The position of the travel control console can also be independently adjusted fore, aft and in height to fit each operator's preference.

Superior visibility on blade and ripper

The redesigned ROPS/FOPS integrated cab and the well-located operator seat give optimal blade visibility to the left and right and make both dozing and grading easy, safe and fast. To further improve safety and ripping efficiency the special shape of the fuel tank gives the operator a clear view of the ripper point and of the dozer's back side.

Less noise and vibrations

The D155AX-6 cab mounts use a cab damper that provides excellent shock and vibration absorption with its long stroke and exclusive design. Cab damper mounts significantly soften shocks and vibrations that conventional mounting systems are unable to absorb.



Excellent visibility on ripper





State of the Art Controls

Hydrostatic steering system

The hydrostatic steering system (HSS) offers fast response and more precise turning. Both tracks are powered without interruption allowing smooth, continuous turns and powerful and productive dozing even on soft ground or on slopes.

Gearshift preset function

To reduce the frequency of gear shifting and for comfortable machine operation, a shift preset mode is provided as standard equipment. The preset switch lets the operator select a combination of forward/reverse gear shifts by using the UP/DOWN shift switch on the steering lever. Once the shift pattern is selected, only forward / reverse direction control selection is required for a correct gear shift.

Easy and precise

The ergonomic Palm Command Control System (PCCS) provides efficient and comfortable steering. The blade control joystick uses Proportional Pressure Control (PPC) for precise operations, excellent and easy grading jobs - and better productivity. When backing up over shot rock or other rough surfaces, travel speed can be reduced with the "slow reverse" function to improve ride quality and decrease vibrations and fuel consumption.



Rear view camera system





Large LCD colour multi monitor

A large user-friendly colour monitor with simple and easy to operate switches enables safe, accurate and smooth work. The TFT (Thin Film Transistor) liquid crystal display can easily be read at various angles and lighting conditions, and the industry-first function keys facilitate multi-function activity.



Tough and Reliable

Low drive undercarriage

Komatsu's undercarriage is extraordinarily tough and offers excellent grading ability and stability. The centre of gravity of the whole machine remains low for safe and stable machine usage on slopes. The low drive undercarriage also greatly reduces the noise levels around the dozer. The heavy-duty link assemblies with large-diameter bushings, substantial track link height and superior oil seals are the basis for a high durable undercarriage – and a drastically lower cost of ownership.

K-Bogie undercarriage system

The K-bogie undercarriage is built with flexible mounted bogie systems that allow a high vertical track roller movement. The 7 track roller/K-bogie design supports and guides the tracks on all ground conditions for a much smoother drive and a longer undercarriage life.

Sturdy, rugged design

A high-rigidity hull structure main frame improves durability and reduces stress concentration at critical areas. The track frame with a large cross section utilizes pivot shaft mounting for greater reliability. All hydraulic piping is robustly protected by cover and inner route to ensure damage protection from materials.

Highly reliable electric circuit

The new generation of Komatsu dozers have special reinforced electrical wiring harnesses covered with a heat-resistant material that improves mechanical strength, provides longer life, and protects the system from damage. The reliability of the D155AX-6's electrical circuit is further increased by the use of "DT connectors" that have a very high resistance to dust, corrosion and moisture and keep your machine up and running.

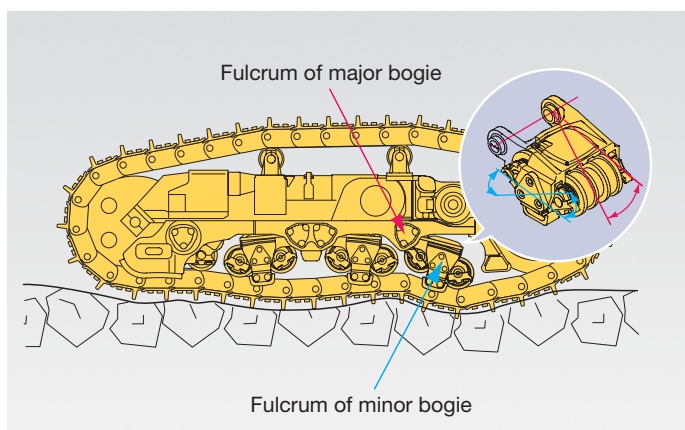



Optimized Work Equipment

Komatsu blades

For increased blade performance and better machine balance, Komatsu uses a box blade design, with the highest resistance for a light weight blade. For increased durability, special Komatsu highly wear resistant steel is used for the front and sides of the blade. The special deep curved design of the blade makes it easy to handle a wide range of materials, with good penetration and a large blade capacity, optimizing high dozing performance with excellent fuel efficiency.

Sigmodozer® blade

The middle section of Komatsu's Sigmodozer® blade acts like a V-shaped bucket with aggressive ground penetration. Its lateral blade edges help to push the rolling material continuously towards the centre. Combined with the blade's deep curve this largely increases effective capacity and reduces spillage and fuel consumption. The blade's flat cutting edge and the standard pitch function also offer top grading performance.

Komatsu rippers

Komatsu's special ripper concept, with all cylinders connected to the ripper shank holder, allows maximum pry-out force. Its key feature is the ripper point movement that lifts up the material during the ripper shank operation to greatly improve overall performance. The shank supplies great penetration into various types of materials and is fitted with special wear parts for increased longevity.

Improved ripper design

The ripper cylinders were reduced from four to two, greatly improving rear visibility during ripping and allowing an extended ripper working area. The new design reduces maintenance costs without losing performance and productivity.

Komatsu-Topcon blade control systems (option)

Automatic blade movements on a dozer greatly improve dozing productivity and grading accuracy. They also allow operators to work faster and more safely with a reduced workload. Komatsu-Topcon blade control systems are the best way to automate blade movements. Depending on the control system used, blade movement can be monitored or fully automated. As a result, even inexperienced operators work much faster and deliver a high-quality final graded area. All the information from the laser or GPS systems is constantly available on an in-cab display, clearly showing the slope and elevation.

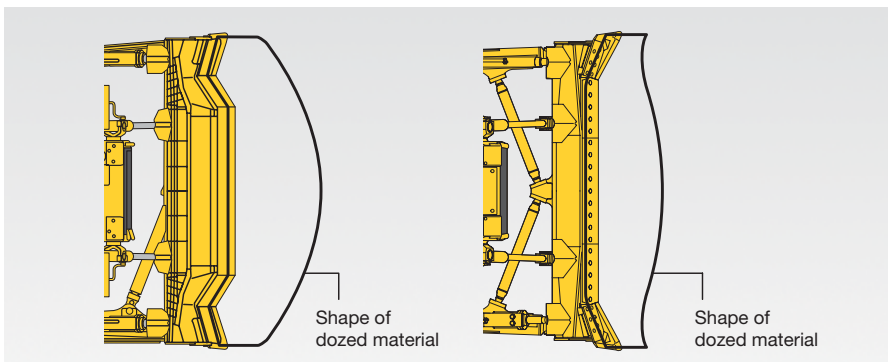

Up to 15% higher production with the Sigmodozer® blade (left), compared to conventional Semi-U blade (right).



The Sigmodozer® blade offers highest material holding capacity



Komatsu Satellite Monitoring System



KOMTRAX™ is a revolutionary machine tracking system designed to save you time and money. You can now monitor your equipment anytime and anywhere. Use valuable machine data received via the KOMTRAX™ web site to optimise your maintenance planning and machine performances.

KOMTRAX™ can assist you with:

Full machine monitoring

Get detailed operation data to know when your machines are used and how productive they are.

Total Fleet Management

Keep track of the location of your machines at all times and discourage unapproved usage or theft.

Complete machine status

Receive warnings, alerts and cautions, via a web site or by e-mail, to help with maintenance planning and for longer machine life.

For further details on KOMTRAX™, please ask your Komatsu dealer for the latest KOMTRAX™ brochure.





Machine working time - With the “daily working record” chart, get precise engine running time data: when your machine was started and when it was shut down, as well as total engine running time.



Maintenance planning - To increase productivity and improve maintenance planning, alerts indicate when items such as filters or oil must be replaced.



Fleet location - The machine list instantly locates all your machines, even those in other countries.



Machine tracking during transport - When your machine is transported, KOMTRAX™ sends travel messages to the web site or by e-mail to inform you of its progress, and confirms when it reaches its destination.



Alarm notifications - You can receive notification of alarms both via the KOMTRAX™ website and by e-mail.



Added security - The “engine lock” feature allows to program when a machine’s engine can be started. And with “geo-fence”, KOMTRAX™ sends notification every time your machine moves in or out of a predetermined operating area.



Easy Maintenance

Centralised service station

Preventative maintenance is essential to ensure the long life of your equipment. Komatsu designed the D155AX-6 with centralised and conveniently located service points to make necessary inspections and maintenance quick and easy.

Reversible radiator fan

The radiator can be cleaned by utilization of the reversible, hydraulically driven cooling fan. The fan can be reversed from inside the cab by simply activating a switch.

Modular power train

All the power train components are enclosed in a sealed module. This eliminates oil spills during mounting and dismounting, and prevents dust and dirt polluting individual components. Servicing is much cleaner, smoother and easier.

Self-diagnostic monitor

Simple warning functions, service interval announcements and key operational functions are displayed on the new centralised monitor panel. At a glance, any operator can select the best options to get the best out of the D155AX-6. In addition, when required, countermeasures are clearly indicated on the screen to enable the operator or service people to quickly take correct and safe action, and keep the machine free of costly major problems and downtime.

Gull-wing engine side cover

Engine maintenance and filter replacement is further facilitated by gull-wing engine side covers that can be easily and safely opened. The opening angle of the covers has been increased to further facilitate access.



ENGINE

Model Komatsu SAA6D140E-5
 Type Common rail direct injection, water-cooled, emissionised, turbocharged, after-cooled diesel
 Engine power
 at rated engine speed 1.900 rpm
 ISO 14396 268 kW / 359 HP
 ISO 9249 (net engine power) 264 kW / 354 HP
 No. of cylinders 6
 Bore x stroke 140 x 165 mm
 Displacement 15,24 ltr
 Fan drive type Hydraulic
 Lubrication system
 Method Gear pump, force lubrication
 Filter Full flow

TORQFLOW TRANSMISSION

Type Komatsu TORQFLOW
 Torque converter 3-element, 1-stage, 1-phase, water-cooled, automatic lock-up
 Transmission Planetary gear, multiple-disc clutch hydraulically actuated, force-lubricated
 Gearshift lock lever and neutral safety switch prevent accidental starts.

MAX. TRAVEL SPEEDS

	Forward	Reverse
1st	3,8 km/h	4,6 km/h
2nd	5,6 km/h	6,8 km/h
3rd L	7,5 km/h	9,2 km/h
3rd	11,6 km/h	14,0 km/h

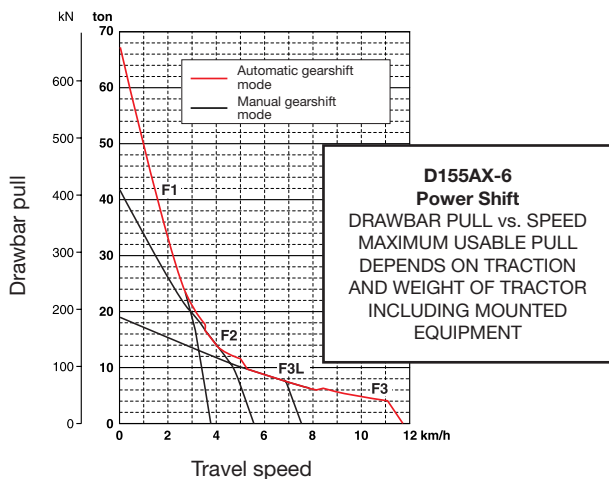

STEERING SYSTEM

Type Hydrostatic Steering System (HSS)
 Steering control PCCS-lever
 Service brakes Wet, multiple-disc, pedal-controlled, spring-actuated and hydraulically released
 Minimum turning radius (counter-rotation)
 (as measured by track marks on ground) 2,14 m

UNDERCARRIAGE

Suspension Oscillating equaliser bar and pivot shaft
 Track roller frame Monocoque, large section, durable construction
 K-Bogie undercarriage Lubricated track rollers are resiliently mounted on the track frame with a bogie suspension system
 Tracks Lubricated tracks, fully sealed
 Track tension Combined spring and hydraulic unit
 Number of shoes (each side) 42
 Grouser height (single grouser) 80 mm
 Shoe width (standard) 610 mm
 Ground contact area 39.955 cm²
 Track rollers (each side) 7
 Carrier rollers (each side) 2

OPERATING WEIGHT (APPR.)

Including strengthened Sigmadozer®, giant ripper, steel cab, ROPS, operator, standard equipment, rated capacity of lubricant, coolant, and full fuel tank
 Operating weight 39.500 kg

SERVICE REFILL CAPACITIES

Fuel tank 625 ltr
 Radiator 82 ltr
 Engine oil 37 ltr
 Damper 1,5 ltr
 Torque converter, transmission, bevel gear and steering system 90 ltr
 Final drive (each side) 31 ltr
 Dozer blade hydraulics 85 ltr
 Giant ripper (additional capacity) 37 ltr
 Multishank ripper (additional capacity) 37 ltr

Specifications

FINAL DRIVE

Type Planetary gear, double-reduction
 Sprocket Segmented sprocket teeth
 are bolt-on for easy replacement

HYDRAULIC SYSTEM

Type CLSS (closed-centre load sensing system)
 All spool valves externally mounted beside the hydraulic tank.
 Main pump Variable displacement piston pump
 Maximum pump flow 325 ltr/min
 Relief valve setting 280 kg/cm²
 Spool control valve positions
 Blade lift Raise, hold, lower, and float
 Blade tilt Right, hold, and left
 Additional control valve positions for ripper
 Ripper lift Raise, hold, and lower
 Ripper tilt Increase, hold, and decrease
 Hydraulic cylinders Double-acting, piston
 No. of cylinders × bore
 Blade lift 2 × 110 mm
 Blade tilt 1 × 160 mm
 Ripper lift 1 × 180 mm
 Ripper tilt 1 × 200 mm

DOZER EQUIPMENT

	Overall length with blade	Blade capacity	Blade width × height	Max. lift above ground	Max. drop below ground	Max. tilt adjustment	Additional weight
Sigmasozer® single tilt	6.125 mm	9,4 m ³	4.060 × 1.850 mm	1.320 mm	617 mm	570 mm	4.940 kg
Sigmasozer® dual tilt	6.125 mm	9,4 m ³	4.060 × 1.850 mm	1.320 mm	617 mm	920 mm	5.020 kg
Strengthened Sigmasozer® single tilt	6.125 mm	9,4 m ³	4.060 × 1.850 mm	1.320 mm	617 mm	570 mm	5.360 kg
Strengthened Sigmasozer® dual tilt	6.125 mm	9,4 m ³	4.060 × 1.850 mm	1.320 mm	617 mm	920 mm	5.450 kg
Semi-U blade single tilt	6.175 mm	9,4 m ³	4.130 × 1.790 mm	1.255 mm	593 mm	575 mm	4.960 kg
Semi-U blade dual tilt	6.175 mm	9,4 m ³	4.130 × 1.790 mm	1.255 mm	593 mm	953 mm	5.050 kg
U blade single tilt	6.590 mm	11,9 m ³	4.225 × 1.790 mm	1.255 mm	593 mm	600 mm	5.630 kg
U blade dual tilt	6.590 mm	11,9 m ³	4.225 × 1.790 mm	1.255 mm	593 mm	970 mm	5.720 kg

Blade capacities are based on the SAE recommended practice J1265.

ENVIRONMENT

Engine emissions Fully complies with EU Stage IIIA and
 EPA Tier III exhaust emission regulations
 Noise levels
 LwA external 111 dB(A) (2000/14/EC)
 LpA operator ear 78 dB(A) (ISO 6396 dynamic test)
 Vibration levels (EN 12096:1997)*
 Hand/arm ≤ 2,5 m/s² (uncertainty K = 0,90 m/s²)
 Body ≤ 0,5 m/s² (uncertainty K = 0,29 m/s²)
 * for the purpose of risk assessment under directive 2002/44/EC,
 please refer to ISO/TR 25398:2006.

RIPPER EQUIPMENT

Multishank ripper
 Type Hydraulically controlled variable ripper
 No. of shanks 3
 Weight (including hydraulic control unit) 3.760 kg
 Beam length 2.320 mm
 Maximum lift above ground 950 mm
 Maximum digging depth 900 mm
 Giant ripper
 Type Hydraulically controlled variable ripper
 No. of shanks 1
 Weight (including hydraulic control unit) 2.440 kg
 Beam length 1.400 mm
 Maximum lift above ground 950 mm
 Maximum digging depth 1.240 mm



DIMENSIONS

	D155AX-6
A	4.060 mm
B	2.140 mm
C	3.385 mm
D	1.850 mm
E	3.275 mm
F	8.225 mm
G	2.745 mm
H	1.240 mm
I	950 mm
J	3.395 mm

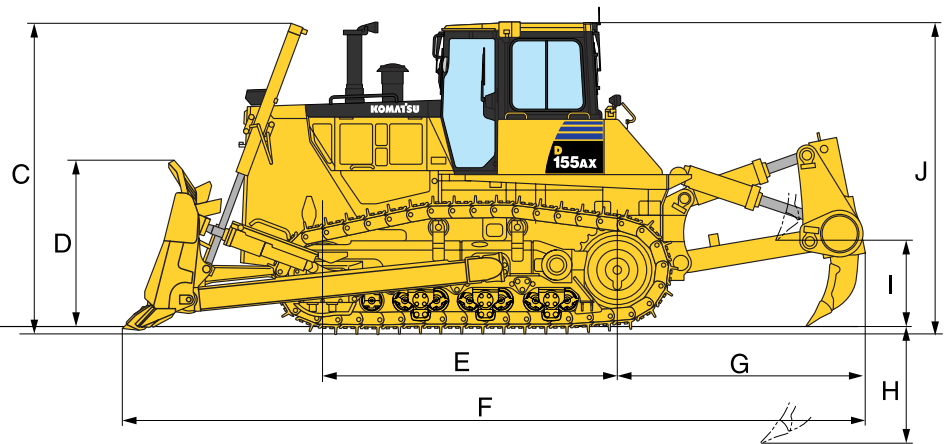
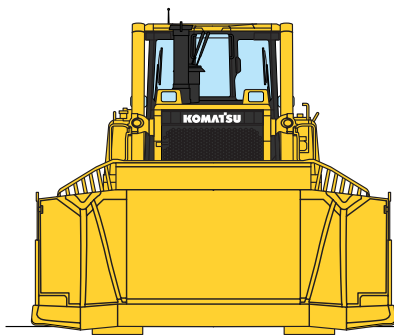
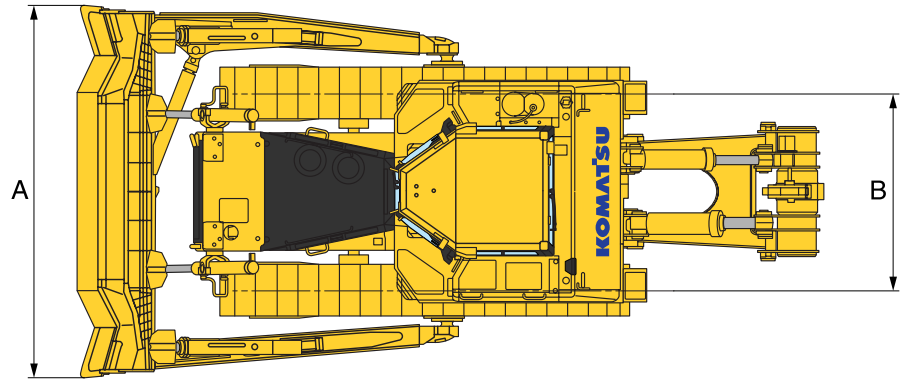

Ground clearance: 500 mm

Crawler Dozer

D155AX-6

Standard and Optional Equipment

ENGINE AND RELATED PARTS

Komatsu SAA6D140E-5 Common rail direct injection diesel engine, turbocharged, EU Stage IIIA/EPA Tier III compliant	●
Locks, filter caps and covers	●
Intake pipe with rain cap	●
Hard water area arrangement using Komatsu Super Coolant	●
Starting motor 24 V/11 kW	●
Alternator 24 V/60 A	●
Batteries 2 × 12 V/170 Ah	●
Gull wing engine side covers	●
Cooling fan, hydrostatic driven with reversing function	●
Damper	●
Electric type engine oil and coolant heater	○
Alternator 24 V/75 A	○
High-capacity batteries 2 × 12 V/220 Ah	○

TRANSMISSION AND BRAKES

Palm lever steering control (PCCS)	●
Automatic hydroshift transmission	●
Decelerator pedal	●
HSS hydrostatic steering system	●
Torque converter with automatic lock-up	●

UNDERCARRIAGE

Single grouser heavy-duty shoes (610 mm)	●
Heavy-duty link assembly, sealed and lubricated	●
Segmented sprockets	●
K-Bogie system	●
Hydraulic track adjusters	●
Single grouser heavy-duty shoes (560 mm, 660 mm, 710 mm)	○
Full length track roller guard	○

CABIN

Suspension seat: fabric, reclining, high backrest, turnable	●
Seat belt	●
Headrest	●
High mount footrest	●
Air conditioner	●
Heated rear window	●
Pre radio installation kit (12 V, antenna, loudspeakers)	●
Fenders	●
Sun visor (rear)	●
Cup holder	●
Lunch box holder	●
Wiper front and rear window	●
Wipers doors	●

SERVICE AND MAINTENANCE

Dry type air cleaner, double element with dust indicator and evacuator	●
Electronic monitor panel	●
KOMTRAX™ - Komatsu satellite monitoring system	●
Tool kit	●
Komatsu-Topcon blade control systems	○

SAFETY EQUIPMENT

Back-up alarm	●
Warning horn	●
Steel cab, meets ISO 3471 and SAE J1040, APR88 ROPS standards, as well as ISO 3449 FOPS standards.	●
Rear-view mirror (inside cab)	●
Rear view camera system	●
Fire extinguisher	○
First aid kit	○
Emergency steering	○

HYDRAULIC SYSTEM

Hydraulics for ripper	●
Hydraulics for dozing blades	●
Mono lever blade control	●

LIGHTING SYSTEM

Additional working light, rear	○
Additional cab lights, front and rear	○
Ripper working light	○

ATTACHMENTS

Front pull hook	●
Rigid drawbar	○
Counterweight + hitch	○

DOZER EQUIPMENT

Sigmadozer® single tilt, 9,4 m³	○
Sigmadozer® dual tilt, 9,4 m³	○
Strengthened Sigmadozer® single tilt, 9,4 m³	○
Strengthened Sigmadozer® dual tilt, 9,4 m³	○
Semi-U blade single tilt, 9,4 m³	○
Semi-U blade dual tilt, 9,4 m³	○
U blade single tilt, 11,9 m³	○
U blade dual tilt, 11,9 m³	○
Multishank variable angle ripper	○
Giant variable angle ripper	○

Further equipment on request

- standard equipment
- optional equipment

Your Komatsu partner:

KOMATSU

Komatsu Europe International NV
 Mechelsesteenweg 586
 B-1800 VILVOORDE (BELGIUM)
 Tel. +32-2-255 24 11
 Fax +32-2-252 19 81
www.komatsu.eu

EESS018005 09/2010

Materials and specifications are subject to change without notice.
KOMATSU is a trademark of Komatsu Ltd. Japan.