

Major equipment

●: Standard ○: Option

	Engine	DX50 Series Diesel
Wet disc brake		
	EPA Tier 3/EU Stage IIIA compliant Diesel engine	●
	Electronic engine control system	●
Engine-related	Heavy duty High Pressure Common Rail system	●
	New combustion system	●
	Air to air charge air cooling system	●
	Overheat prevention function	●
	Auto engine warm-up function	●
	Auto air pre-heat function	●
Traveling-related	Large capacity radiator	●
	Dual floating structure	●
	New operator's seat with suspension	●
	Tiltable steering column	●
	Electric forward/reverse lever	●
	Combination switch (turn signal light & light switch)	●
Meters	Indicator auto-return mechanism	●
	Wide slip-resistant step	●
	Paper binder at engine hood	●
	Meter panel	●
	Hourmeter (6-digit)	●
	Engine cooling water temperature gauge	●
Indicators	Torque converter oil temperature gauge	●
	Fuel gauge	●
	Lifting interlock lamp	●
	Charge warning lamp	●
	Neutral indicator	●
	Failure indicator	●
Electric components	Engine failure indicator	●
	Air cleaner element warning lamp	●
	Cooling water level warning lamp	●
	Glow indicator	●
	Large capacity alternator	●
	Quick auto glow system	●
Mechanism	Neutral start function	●
	Auto fuse	●
	Low maintenance battery	●
	Engine key stop function	●
	Halogen headlight	●
	Rear combination light	●
Exterior	Back-up buzzer	●
	Operator Presence Sensing system	●
	Sedimenter with priming pump	●
	Cyclone air cleaner (double element)	●
	Parking brake with release button	●
	Fully hydrostatic power steering	●
Exterior	Steering knob synchronizer function	○
	Non-asbestos parking brake linings	●
	Key-off lift lock	●
	Floor mat	●
	Assist grip	●
	Overhead guard with front/rear conduits	●
Exterior	Rearview mirrors (pair)	●
	Full shield solid-state engine hood	●
	Easy-removable floor panel	●
	Easy-removable radiator cover	●
	Engine hood lock	●
	Radiator reservoir tank	●
Exterior	Jacking points	●

Options

Engine & power train related

- Extra fuel filters
- Pre-cleaner
- Upward exhaust muffler
- Automatic transmission
- Steering knob synchronizer function

Exterior

- Canvas cabin
- Steel cabin
- Heater
- Air-conditioner
- Tilt cylinder boots
- Power steering cylinder boots
- Fuel cap with key
- Front glass with wiper
- Fire extinguisher
- Rear under mirror

Electrical equipment

- Headlights, 2-stage (High-Low)
- Mast mount type head lights
- Rear working light
- Yellow strobe light

Meters & gauges

- Speedmeter with alarm
- Mast tilt angle gauge

Tyre-related

- Elastic cushion tyre (6.0 & 7.0 ton)

Mast

● 2-stage free view mast

The mast enables a wide view with excellent forward visibility.

● 2-stage full free view mast

This is ideal for sites with height limitations, where the large free lift is required.

● 3-stage full free view mast

The mast extends in three stages and high level loading is easily performed.

Attachments

● Side shifter

The fork may be shifted sideways together with its backrest, both to the right and to the left.

● Fork positioner

The operator is able to adjust the fork spread width from the operator's seat.

● Fork positioner with side shifter

The combination of fork positioner and side shifter.

● Fork positioner with side shift function

This attachment is a fork positioner which has a simultaneous fork movement function to act as a side shifter.

● Hinged fork

The fork tilts up/down using its hinge as a fulcrum.

● Bale clamp

This attachment is recommended for handling packed pulp or raw cotton. The bale is efficiently held from both sides by the bale clamps.

DX50 Series

6.0 / 7.0 / 8.0 ton DIESEL FORKLIFT TRUCKS

EPA Tier 3 / EU Stage IIIA Emission Compliant



www.Komatsu.com

Printed in Japan 1012-2-01shi

KOMATSU®

Form No. BR-DX50emi-002

Materials and specifications are subject to change without notice

KOMATSU is a trademark of Komatsu Ltd. Japan

"Reducing Total Operating Costs" with Komatsu Innovative Technologies

The fusion of advanced engines and Komatsu's unique hydraulic system enables the new DX50 Series to achieve a significant reduction in the total operation costs and facilitates superior work performance. Our innovative machines challenge the conventional concept of the forklift.

Komatsu's Hydraulic System and the NEW Diesel Engine Reduce the Fuel Consumption KOMATSU ONLY

In order to minimize the engine load, the new DX50 Series adopts the Komatsu's latest hydraulic system. The compact 3.3-liter engine features superior performance and achieves up to 20% less fuel consumption.

Fuel Consumption
Max. 20% saving

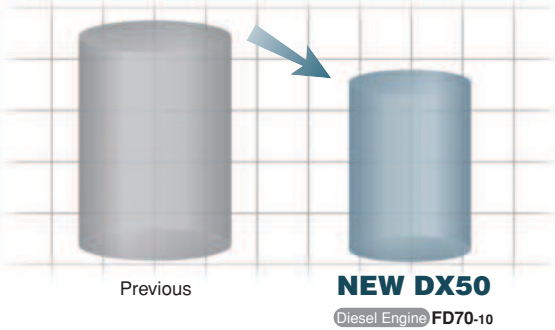

Komatsu tested data, comparison with FD70-8 model. The results may vary depending on conditions.

■ Komatsu's Latest Hydraulic System Contributes Low Fuel Consumption

As the engine speed changes, the engine RPMs control pump detects the engine revs. and controls the oil feed to reduce the load on the engine. This hydraulic system offers optimized balancing of traveling and loading work, making it ideal for forklift operations that often put complex demands on the engine such as starting/acceleration while performing lift operations.

- Optimally controlled hydraulic oil results in;
- Optimized balancing of traveling and loading work
 - Achieved compact 3.3 liter engine equip

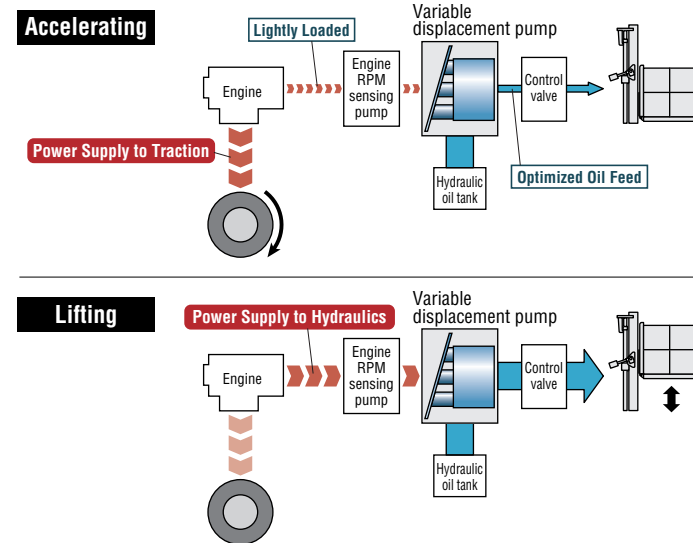

Greatly Reduced Total Operating Costs

The sealed wet disc brakes can withstand about 10,000* hours operation without maintenance and eliminating frequent brake shoes replacements. The engine oil replacement interval has been extended for 300 hours, which reduces oil costs. The reduced maintenance costs and significant fuel saving provide a total operating cost reduction of about 14% over eight years of usage. *A periodical check and oil replacement are necessary. Komatsu genuine engine oil is recommended.

■ Running cost (Accumulated costs for 8 years)

Assuming FD70-8 as 100%;



■ Total operating cost (*Image)

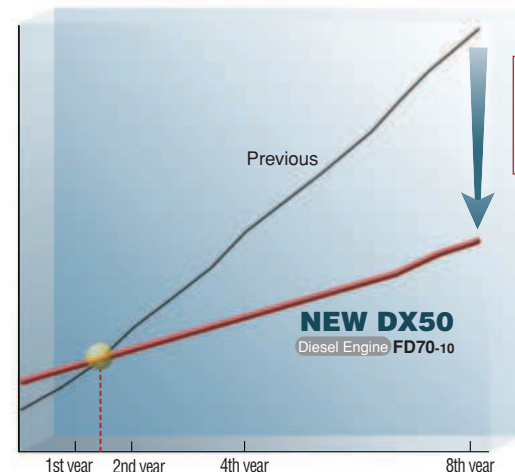

Total operating cost
Approx. 14% saving
(8 years)

Komatsu tested data, comparison with FD70-8 model. Operation hours: 5 h/day, 25 days/month (Total: Approx. 1500 h/year). Maintenance intervals to manufacturer's recommendation. Cost calculation is based on Japanese market price. The results may vary depending on conditions.

The Advanced Technology Offers Reduced CO₂ Emissions



The new DX50 Series feature the SAA4D95LE-5-A engine in combination with Komatsu's efficient hydraulic system. This arrangement enables a reduction in annual CO₂ emissions by about 7.1 tons.

Annual CO₂ emissions
About 7.1 tons reduction

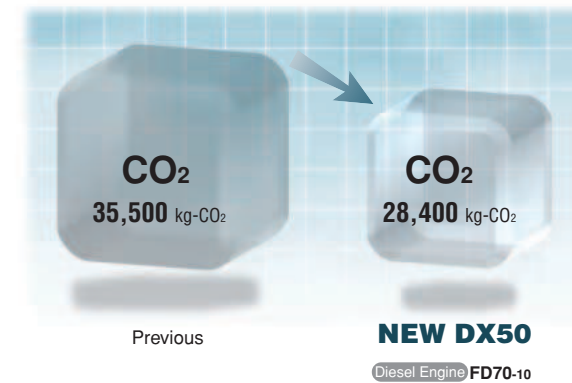

Komatsu tested data, comparison with FD70-8 model. The CO₂ emission coefficient is given in the Common Guidelines of the Japanese METI and MLIT (April 2006). The results may vary depending on conditions.

■ An Advanced Diesel Engine Conforms to the Latest Emission Regulations

Low fuel consumption and low environmental impact are enabled by elimination of excess combustion and the use of the combined technologies of the high pressure common rail system, electronic control system, new combustion system and air to air charge air cooling system.

EPA Tier 3 / EU Stage IIIA Emission Compliant



SAA4D95LE-5-A
Displacement:
3,260 cm³
Rated Output:
69.0 kW @ 2,250 min⁻¹
Maximum Torque:
343 Nm @ 1,600 min⁻¹



Superior "Productivity" and "Reliability" Satisfy Demanding Operations

Durable Wet Disc Brakes to Withstand Severe Conditions

The wet disc brake is sealed with oil to block dust penetration, providing durable, water resistant and fade resistant characteristics. Smooth, stable braking provides "Productivity" and "Reliability" in demanding operation.

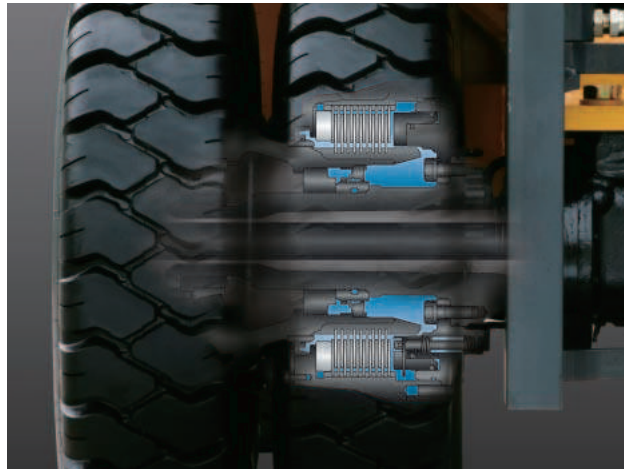

A Cooling System to Achieve Increased Braking Stability

The oil in the wet disc brake system is circulated through the brake oil cooler. This mechanism ensures stable braking under a heavy work load and prevents deterioration of the braking force due to raised oil temperatures.

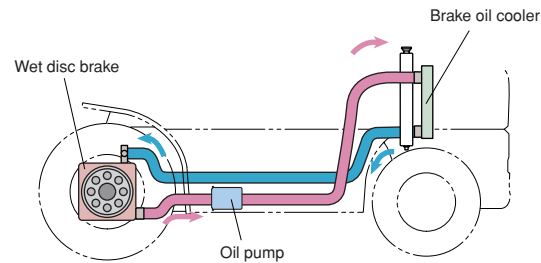

- Steady breaking is always achieved.
- Overheating of the brakes is prevented.
- Downtime and maintenance costs are reduced.



First-class Productivity is Achieved

First-class Cycle Time

The new DX50 Series adopts a compact 3.3-liter engine in conjunction with Komatsu's advanced hydraulic system. This arrangement features high productivity and achieves a first class cycle time.

- The NEW DX50 Series achieves high productivity equivalent to the previous DX20 Series.

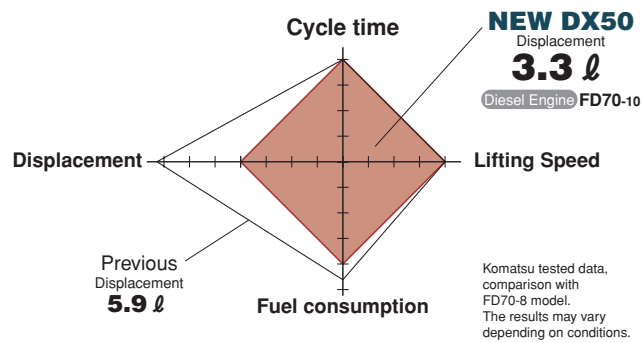

- Lifting Speed (Loaded)
Diesel Engine FD70-10
450 mm/s

- Traveling Speed (Unloaded)
Diesel Engine FD70-10
31.0 km/h

Fully Hydrostatic Power Steering for Superb Maneuver

The FHPS (Fully Hydrostatic Power Steering) mechanism facilitates fully stationary steering as well as switchback operations using the small diameter steering wheel. The system has a superior response capability so that the operator can pick up or place cargo flexibly even in a narrow space. In addition, steering knob synchronizer function is available as an option.

The 8.0 ton model offers a significant size reduction

The 8.0 model features a shorter wheelbase and swift mobility while maintaining the power and speed capable of achieving high productivity. The DX50 8.0 ton model is an ideal choice for confined spaces.

- Length
4890 mm
5095 mm [Previous 8.0 ton model]
- Width
2050 mm
2120 mm [Previous 8.0 ton model]
- Turning radius
3450 mm
3600 mm [Previous 8.0 ton model]

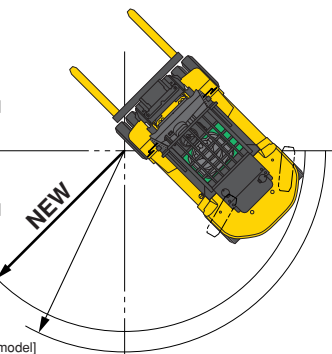

Excellent Durability for Demanding Work

Rugged Design with High Rigidity

The high rigidity mast, frame, front and rear axles ensure outstanding reliability even when performing heavy-duty work.

[Mast]

A heavy mast rail profile for excellent rigidity.

[Frame]

The successful high rigidity structure of previous models is adopted.

[Front axle]

The proven reliable design of previous models is adopted.

[Rear axle]

The durability of the power steering cylinders is improved.

Improved Reliabilities for the Hydraulic and Electrical Systems

The main hydraulic pipe connectors are face-sealed using O-rings. Waterproof connectors are provided to the main harnesses and the system controller in order to provide higher resistance to water and dust. Hydraulic and electrical piping systems are in separate configurations to improve the reliability and servicing.

Engine Protection for Maintaining the Engine in Top Condition

The electronic engine controls upgrade the performance of the engine protection (fail-safe functions).

- Trouble diagnosis: Engine malfunctions are automatically detected and an alarm lamp blinks.
- Overheating prevention (Diesel): The engine output and RPMs are reduced when the coolant temperature is high.
- Automatic engine warm-up (Diesel): The RPMs are accelerated to warm up the engine at low temperatures.
- Automatic air pre-heating (Diesel): The engine is automatically pre-heated when starting it at low temperatures.



Engine failure indicator



Careful Design Facilitates Inspection and Servicing

Filter Layout Optimization for Improved Serviceability

A fully-opening floor plate.

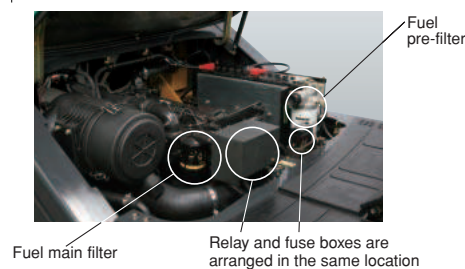

Fuel main filter, Fuel pre-filter, Relay and fuse boxes are arranged in the same location

Easy Radiator Cleaning



Wide Opening Engine Hood with a Lock for Easy Servicing



Engine hood locking provides safety servicing

