

KOMATSU®

PC138USLC-2 With Tier 2 SAA4D95LE-3-A Engine

NET HORSEPOWER

66.2 kW **89 HP** @ 2200 rpm

OPERATING WEIGHT

14000–14760 kg **30,860–32,537 lb**

BUCKET CAPACITY

0.35–0.70 m³ **0.46–0.92 yd³**

PC
138
USLC

HYDRAULIC EXCAVATOR



Photo may include optional equipment.

GALEO

WALK-AROUND

Working in congested or confined areas can be a challenge. Komatsu's PC138USLC-2 hydraulic excavator has a short tail swing profile, designed for work in confined areas. By reducing tail swing, the PC138USLC-2 can work in areas where conventional profile excavators would pose a safety risk. Perfect for work on roadways, urban areas, or anywhere space is limited, the PC138USLC-2 provides you with the performance and productivity you expect from Komatsu equipment.

Larger Cab

- Komatsu's low noise design cab is a fully pressed high-rigidity cab that uses viscous cab mounting for reduced noise
- Sliding convex door facilitates easy entrance in confined areas and reduces the danger of being damaged on roadways because the door does not protrude when open
- Komatsu's large cab meets ISO working space standards to provide secure, safe, and comfortable operation



Intermittent Wiper is useful for light rain.



Aluminum Oil Cooler provides excellent thermal conductivity, improving heat balance without increasing the fan rotating speed, which contributes to reducing the noise level.

High Mobility

Large drawbar pull and steering force provide great travel performance.

Narrow Width

Komatsu's PC138USLC-2 occupies a road width of 3.46 m **11'4"** or less. This allows the machine to work on either side of a 7 m **23'** wide road without having to close both sides of the road.

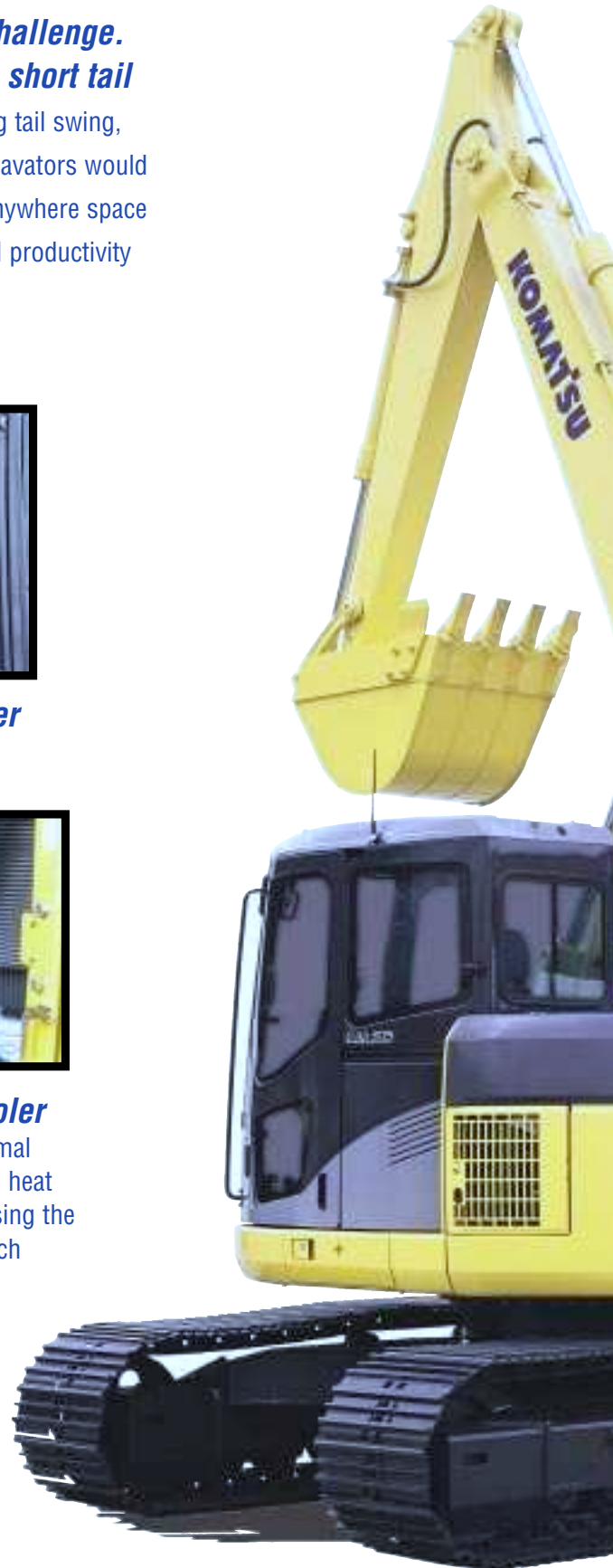

Wide Working Ranges

Maximum digging height of the PC138USLC-2 is larger than that of the PC120LC-6. Raising the boom on the PC138USLC-2 to a wider angle enhances overall working performance. Job sites that require a long upper reach, such as demolition and slope cutting, also benefit from the increased digging and dumping ranges of the PC138USLC-2.

High Stability

The PC138USLC-2 offers exceptional lifting capacity and high stability with a large cast-iron counterweight.

Safe Operation

The PC138USLC-2's compact design helps prevent impact damage to the environment and machine.

NET HORSEPOWER

66.2 kW **89 HP** @ 2200 rpm

OPERATING WEIGHT

14000–14760 kg

30,860–32,537 lb

BUCKET CAPACITY

0.35–0.70 m³ **0.46–0.92 yd³**

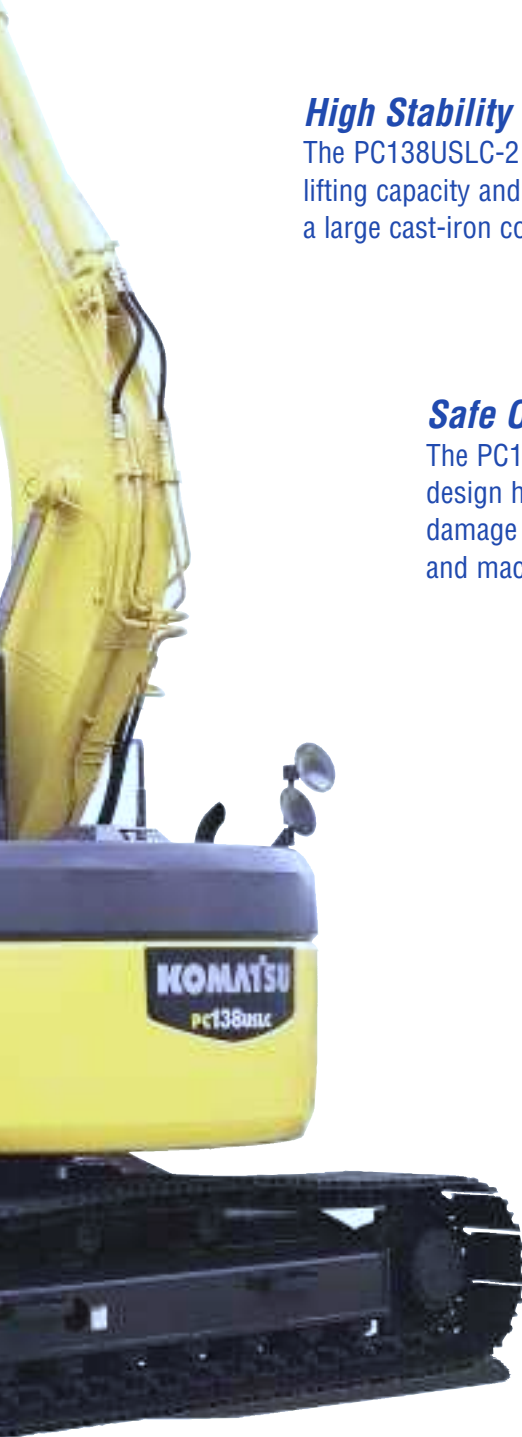

Pump/Engine Room Partition

prevents oil from spraying on the engine if a hydraulic hose should burst.

SAA4D95LE-3-A Turbocharged Aftercooled Diesel Engine

provides an output of 66.2 kW **89 HP** with excellent productivity. This engine is Tier 2 EPA, EU and Japan emissions certified.



Komatsu's highly productive, innovative technology, environmentally friendly machines built for the 21st century.

Photo may include optional equipment.

PRODUCTIVITY FEATURES

Safe Operation With Small Tail Swing Even in Confined Areas

Short implement swing radius:

Boom raising angle of the PC138USLC-2 is larger than a conventional profile excavator. The result is a reduced front implement radius.

Short tail swing radius:

Because the tail of the PC138USLC-2 is more compact than conventional models, the PC138USLC-2 reduces the potential for impact damage to the machine and environment.

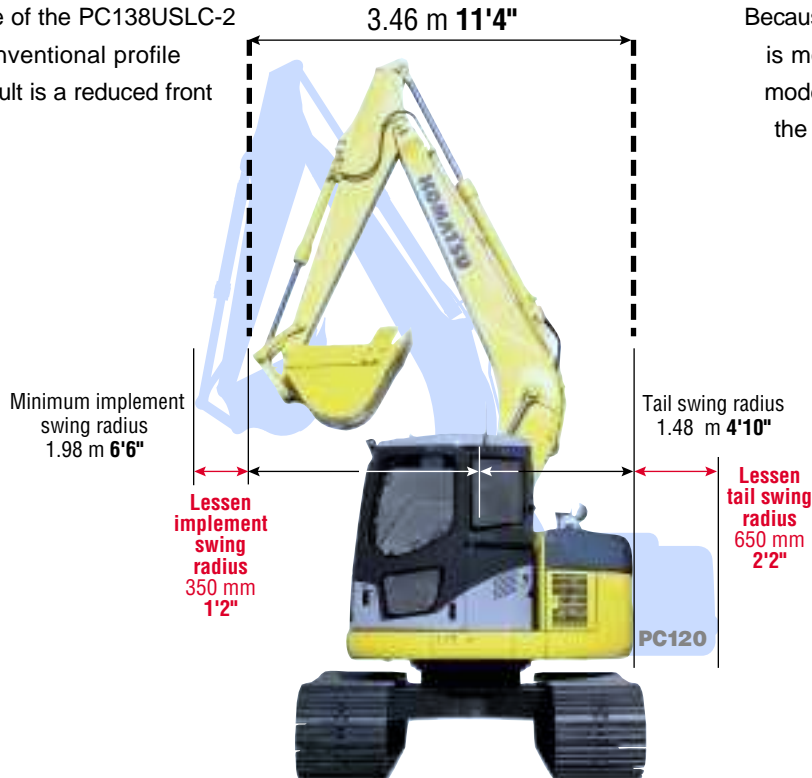

Track Protrusion

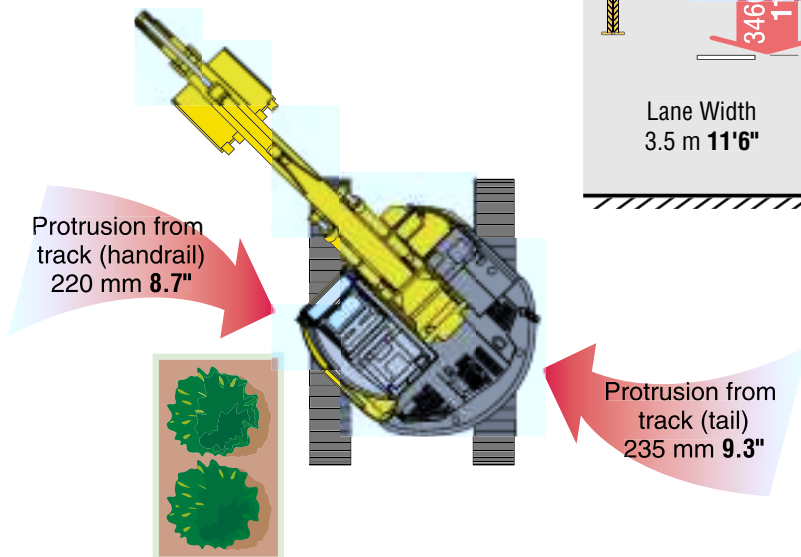

Road Work

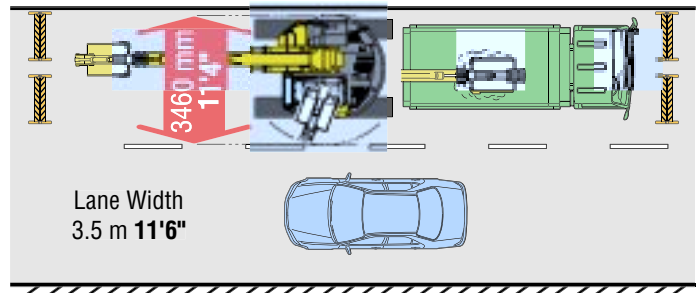

Logging Road Work

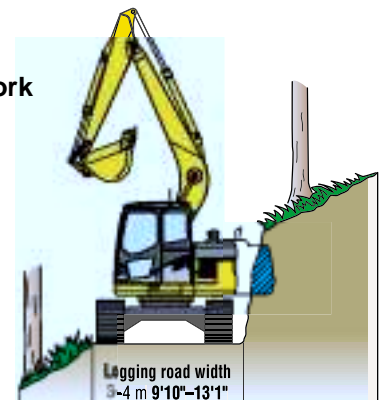

Excellent Productivity

Engine

The PC138USLC-2 gets its exceptional power and work capacity from the Komatsu SAA4D95LE-3-A engine. Output is 66.2 kW **89 HP**, giving you increased hydraulic power with maximum fuel efficiency. This engine is Tier 2 EPA, EU, and Japan emissions certified. Noise levels have also been reduced for greater operator comfort.

Wider Working Ranges

Raising the boom on the PC138USLC-2 to a wider angle enhances overall working performance.

Job sites that require a long upper reach, such as demolition and slope cutting, also benefit from the increased digging and dumping ranges of the PC138USLC-2.



Large Digging Force

The PC138USLC-2 has a large bucket digging force and arm crowd force, facilitating digging hard rock-bed. Digging force SAE rating.

	PC138USLC-2
Bucket digging force	7950 kgf 17,530 lb
Arm crowd force	5550 kgf 12,240 lb

(2.5 m 8'2" arm)

High Stability

The PC138USLC-2 offers exceptional lifting capacity and high stability with a large cast-iron counterweight that requires no additional clearance.

	PC138USLC-2	PC120LC-6
Lifting capacity*	1320 kg 2,910 lb	1350 kg 3,000 lb
Weight of counterweight	3420 kg 7,540 lb	2255 kg 4,960 lb

(2.5 m 8'2" arm)

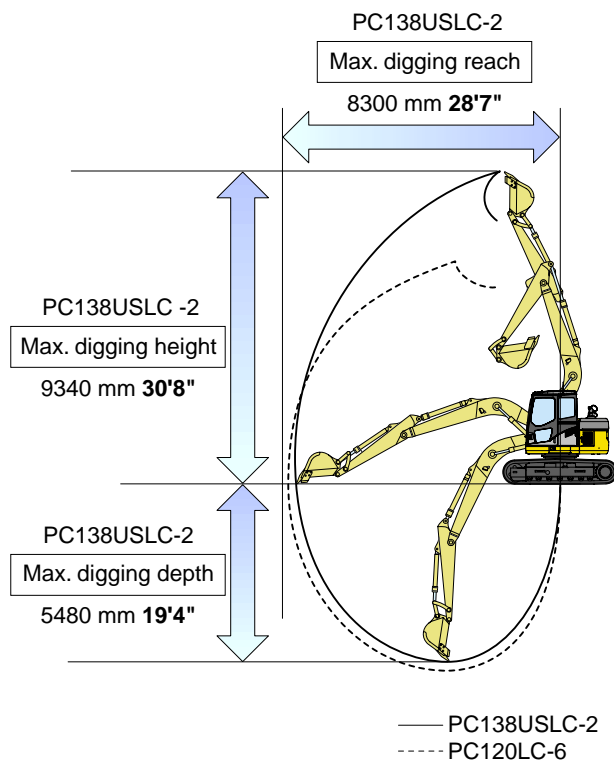

	PC138USLC-2	PC120LC-6
Maximum digging height	9340 mm 30'5"	8610 mm 28'3"
Maximum digging depth	5480 mm 17'9"	5520 mm 18'1"
Maximum dumping height	6840 mm 22'8"	6170 mm 20'3"

Easy Operation

Self-Diagnostic System

The PC138USLC-2 features one of the most advanced diagnostic systems in the industry. Komatsu's exclusive system identifies maintenance items, reduces diagnostic time, and helps you maintain maximum production.



Working Mode	Application	Advantage
A	Active Mode	<ul style="list-style-type: none"> ● Maximum production/power ● Fast cycle times
E	Economy Mode	<ul style="list-style-type: none"> ● Good cycle times ● Good fuel economy
B	Breaker Operation	<ul style="list-style-type: none"> ● Optimum engine rpm, hydraulic flow, and pressure

PRODUCTIVITY FEATURES

The PC138USLC-2 cab interior is spacious and provides a comfortable working environment...

Large Operator's Cab

Large Size Cab

The PC138USLC-2 employs a new convex shape, large size cab that provides a comfortable operating environment.

Multi-Position Controls

The multi-position, pressure proportional control levers allow the operator to work in comfort while maintaining precise control.

A double-slide mechanism allows the seat and controllers to move together or independently, allowing the operator to position the controllers for maximum productivity and comfort.

Cab Mount

The cab rests on viscous damping mounts to reduce vibration and noise from the machine body. Operator fatigue is reduced.

Sliding Convex Door

The sliding convex door facilitates entrance in confined areas and reduces the danger of being damaged on roadways because the door does not protrude when open.

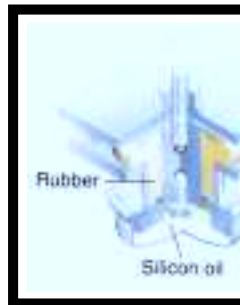
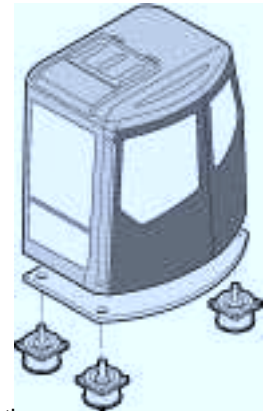

Cab volume 1.11 times larger than before

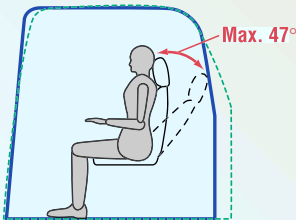
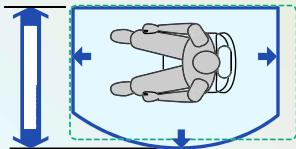

— PC138US-2
- - - PC120-6



Low Noise

Komatsu's low noise design uses a partition between the cab and engine room, an airtight valve room, and viscous cab mounting to reduce noise levels to 72 dB(A) at operator's ear.



Skylight



Washable Floor

The PC138USLC-2's floor is easy to keep clean. The gently inclined surface has a flanged floor mat and drainage holes to facilitate runoff.



Photos may include optional equipment.

MAINTENANCE FEATURES

Easy Maintenance

Komatsu designed the PC138USLC-2 to have easy service access. By doing so, routine maintenance and servicing are less likely to be skipped, which can mean a reduction in costly downtime later on. Here are some of the many service features found on the PC138USLC-2.



Optimum Maintenance Layout

With the left and right side service doors, it is possible to access the major maintenance points from ground level.

Furthermore, the fuel drain valve, engine oil filter, swing machinery oil filler, and PTO oil filler are remote mounted, facilitating easy maintenance.

New Hybrid Filter Element

The new hybrid element in the hydraulic circuit filter extends the element replacement interval to 500 hours and the hydraulic oil replacement interval to 5,000 hours.

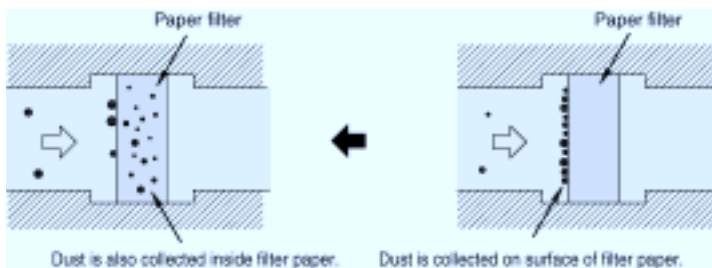
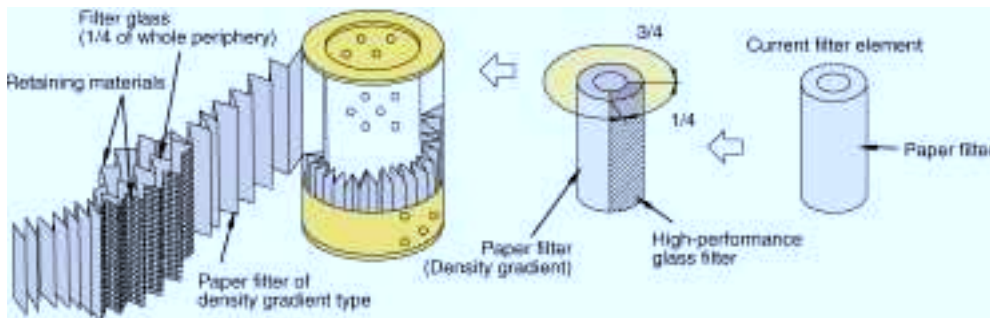
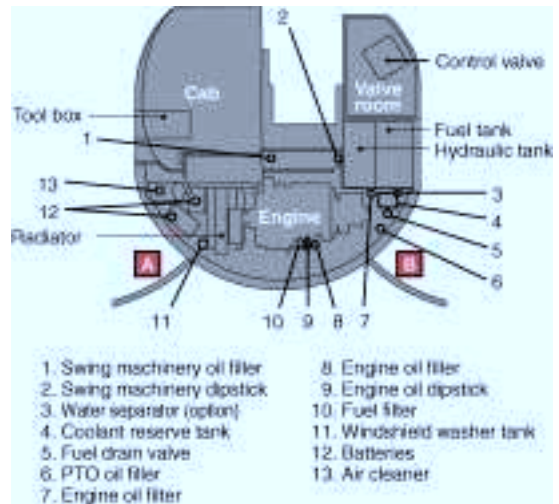

- High-performance glass-type filter is employed for 25% of the total filter area
- Pore gradient-type paper media is used
- The filter area is larger and has a longer life than pore gradient-type paper media because it collects dust three-dimensionally

Large Tool Box

Large tool box provides plenty of space. Grease pump storage space is also provided.



RELIABILITY AND SAFETY

Safety Features

Excellent Reliability

Dustproof Radiator Net

The dustproof radiator net prevents dust from entering into the radiator core and causing engine overheating.

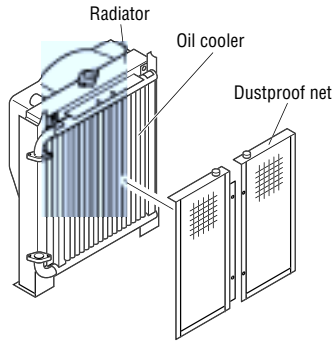

Dustproof Radiator Net

Wave Fin Radiator

A high cooling efficiency wave fin is used on the radiator.

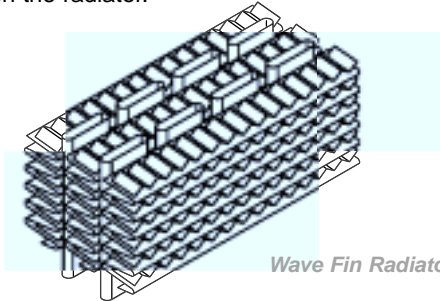

Wave Fin Radiator

Dual Filter Air Cleaner

A dual filter air cleaner is employed to prevent dust from entering the engine.

Metal Guard Ring

The metal guard ring protects all the hydraulic cylinders from seizure and improves reliability.

DT Connectors

Water resistant DT connectors are used to improve wiring harness reliability.



Pump/engine room partition prevents oil from spraying on the engine if a hydraulic hose should burst.

Large handrail is installed for getting on/off machine cab safely.

Steps with no-skid sheet

provide anti-skid footing for maintenance.



Boom holding valve reduces hydraulic drift of boom.



Hammer for emergency is provided to break cab glass for escape in case of emergency.

PC138USLC-2 HYDRAULIC EXCAVATOR

SPECIFICATIONS



ENGINE

Model Komatsu SAA4D95LE-3-A
 Type Water cooled, 4-cycle, direct injection
 Aspiration Turbocharged, and air-to-air aftercooled
 Number of cylinders 4
 Bore 95 mm **3.74"**
 Stroke 115 mm **4.53"**
 Piston displacement 3.26 ltr **199 in³**
 Horsepower:
 Gross 69.2 kW **93 HP @ 2200 rpm**
 Net 66.2 kW **89 HP @ 2200 rpm**
 Governor All speed control, mechanical
 This engine is Tier 2 EPA, EU, and Japan emissions certified.
 Starting motor 4.5 kW/**24 V**
 Alternator 25 A/**24 V**
 Battery 72 Ah/**2 x 12 V**



HYDRAULICS SYSTEM

Type HydraMind (Hydraulic Mechanical Intelligence New Design) system, Closed-center system with load-sensing valve and pressure-compensated valve
 Main pump:
 Type Variable capacity piston type
 Pumps for Boom, arm, bucket, swing, and travel circuits
 Maximum flow 226 ltr/min **59.7 U.S. gal/min**
 Hydraulic motors:
 Travel 2 x piston motor with parking brake
 Swing 1 x piston motor with swing holding brake
 Relief valve setting:
 Implement circuits 31.9 MPa 325 kgf/cm² **4,620 psi**
 Travel circuit 34.8 MPa 355 kgf/cm² **5,050 psi**
 Swing circuit 27.5 MPa 280 kgf/cm² **3,980 psi**
 Pilot circuit 2.9 MPa 30 kgf/cm² **430 psi**
 Hydraulic cylinders:
 (Number of cylinders – bore x stroke)
 Boom 2–105 mm x 1055 mm **4.1" x 41.5"**
 Arm 1–115 mm x 1175 mm **4.5" x 46.3"**
 Bucket 1–100 mm x 885 mm **3.7" x 34.8"**



SWING SYSTEM

Driven by Hydraulic motor
 Swing reduction Planetary gear
 Swing circle lubrication Grease-bathed
 Swing lock Wet, multiple-disc brake
 Swing speed 11.0 rpm
 Swing torque 2991 kg.m **21,627 ft lbs**



STANDARD EQUIPMENT

- Air cleaner, double element with auto dust evacuator
- Air conditioner
- Alternator, 25 Ampere, 24 V
- Batteries, 72 Ah/2 x 12 V
- Cab which includes: Antenna, AM/FM radio, floor mat, intermittent front windshield wiper and washer, large ceiling hatch, pull-up front window, removable lower windshield, sliding seat
- Cooling fan, mixed flow with fan guard
- Counterweight, 3420 kg **7,540 lb**
- Dustproof net for radiator and oil cooler
- Monitor panel
- Light, one front



DRIVES AND BRAKES

Steering control Two levers with pedals
 Drive method Fully hydrostatic
 Maximum drawbar pull 123 kN 12500 kgf **27,550 lbf**
 Maximum travel speed: High 5.1 km/h **3.2 mph**
 Low 3.2 km/h **2.0 mph**
 Service brake Hydraulic lock
 Parking brake Wet, multiple-disc



UNDERCARRIAGE

Center frame X-leg frame
 Track frame Box-section
 Seal of track Sealed track
 Track adjuster Hydraulic
 Number of shoes 46 each side
 Number of carrier rollers 2 each side
 Number of track rollers 8 each side



COOLANT AND LUBRICANT CAPACITY (REFILLING)

Fuel tank 200 ltr **52.8 U.S. gal**
 Radiator 18.2 ltr **4.8 U.S. gal**
 Engine 17.0 ltr **4.5 U.S. gal**
 Final drive, each side 2.5 ltr **0.7 U.S. gal**
 Swing drive 2.5 ltr **0.7 U.S. gal**
 Hydraulic tank 69.0 ltr **18.2 U.S. gal**



OPERATING WEIGHT (APPROXIMATE)

Operating weight including 4600 mm **15'1"** one-piece boom, 2500 mm **8'2"** arm, SAE heaped 0.35 m³ **0.46 yd³** backhoe bucket, rated capacity of lubricants, coolant, full fuel tank, operator, and standard equipment.

Shoes		Operating Weight		Ground Pressure		
mm	in	kg	lb	kPa	kg/cm ²	psi
500*	20"	14400	31,758	42.2	0.43	6.16
600	24"	14050	30,980	34.3	0.35	4.98
700	28"	14150	31,195	30.2	0.30	4.30

*includes the blade weight

- Auto deceleration
- Pump/engine partition cover
- Rearview mirror
- Shoe, 600 mm **24"** triple grouser
- Starting motor 4.5 kW
- Swing holding brake



DIMENSIONS

	Boom Length	4600 mm	15'1"	4600 mm	15'1"	4600 mm	15'1"
	Arm Length	2500 mm	8'2"	3000 mm	9'10"	2100 mm	6'11"
A	Overall length	7395 mm	24'3"	7295 mm	23'11"	7410 mm	24'4"
B	Overall height (to top of boom)	2850 mm	9'4"	3190 mm	10'6"	2690 mm	8'10"
C	Length on ground (transport)	4540 mm	14'11"	4400 mm	14'5"	4690 mm	15'5"
D	Overall width	2590 mm	8'6"				
E	Overall height (to top of cab)	2815 mm	9'3"				
F	Ground clearance, counterweight	900 mm	2'11"				
G	Minimum ground clearance	395 mm	1'4"				
H	Tail swing radius	1480 mm	4'10"				
I	Length of track on ground	3100 mm	10'2"				
J	Track length	3840 mm	12'7"				
K	Track gauge	1990 mm	6'6"				
L	Width of crawler	2590 mm	8'6"				
M	Shoe width	600 mm	24"				
N	Grouser height	25 mm	1.0"				
O	Machine cab height	1980 mm	6'6"				
P	Machine cab width	2515 mm	8'3"				
Q	Distance swing center to rear end	1480 mm	4'10"				

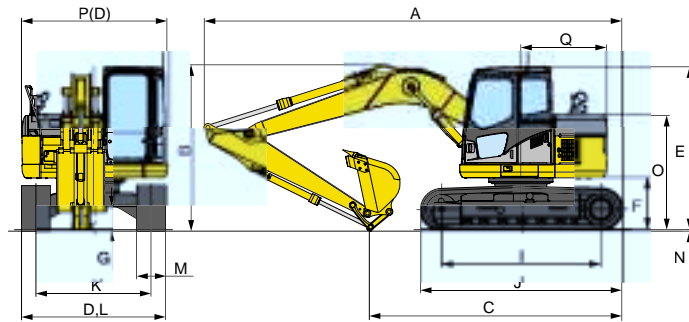
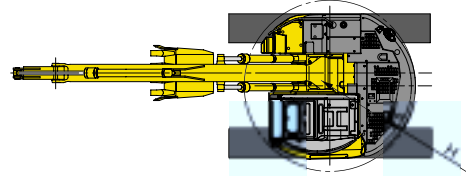

WORKING RANGE

	Boom	4600 mm	15'1"	4600 mm	15'1"	4600 mm	15'1"
	Arm	2500 mm	8'2"	3000 mm	9'10"	2100 mm	6'11"
A	Maximum digging height	9340 mm	30'8"	9700 mm	31'10"	9020 mm	29'7"
B	Maximum dumping height	6840 mm	22'5"	7350 mm	24'1"	6525 mm	21'5"
C	Maximum digging depth	5480 mm	18'0"	5900 mm	19'4"	5070 mm	16'8"
D	Maximum vertical wall digging depth	4900 mm	16'1"	5340 mm	17'6"	4490 mm	14'9"
E	Maximum digging depth of cut for 2440 mm 8' level	5265 mm	17'3"	5715 mm	18'9"	4835 mm	15'10"
F	Maximum digging reach	8300 mm	27'3"	8720 mm	28'7"	7930 mm	26'0"
G	Maximum digging reach at ground	8180 mm	26'10"	8600 mm	28'3"	7805 mm	25'7"
H	Minimum swing radius	1980 mm	6'6"	2250 mm	7'5"	1845 mm	6'1"
ISO rating	Bucket digging force	93.2 kN 9500 kgf	20,940 lbf	88.3 kN 9000 kgf	19,840 lbf	88.3 kN 9000 kgf	19,840 lbf
	Arm crowd force	61.8 kN 6300 kgf	13,890 lbf	55.9 kN 5700 kgf	12,570 lbf	71.6 kN 7300 kgf	16,090 lbf
SAE rating	Bucket digging force	81.4 kN 8300 kgf	18,300 lbf	78.0 kN 7950 kgf	17,530 lbf	78.0 kN 7950 kgf	17,530 lbf
	Arm crowd force	60.8 kN 6200 kgf	13,670 lbf	54.4 kN 5550 kgf	12,240 lbf	69.6 kN 7100 kgf	15,650 lbf

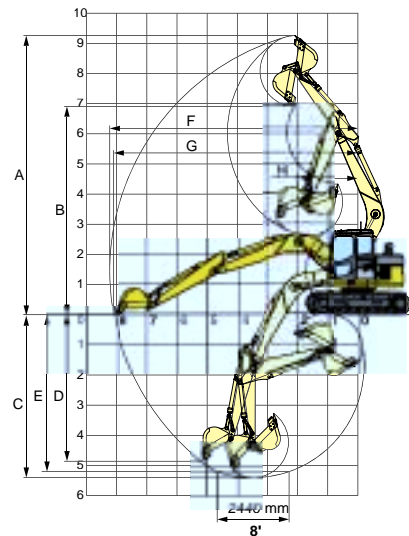

BACKHOE BUCKET AND ARM COMBINATION

Bucket Type	Bucket						Arms			
	Capacity		OLW	Weight		Number of Teeth	6'11"	8'2"	9'10"	
Komatsu "H" Series HD	0.35 m ³	0.46 yd ³	610 mm	24"	421 kg	928 lb	4	V	V	V
	0.50 m ³	0.65 yd ³	762 mm	30"	463 kg	1,021 lb	5	V	V	W
	0.60 m ³	0.79 yd ³	914 mm	36"	525 kg	1,157 lb	5	W	X	Y
	0.70 m ³	0.92 yd ³	1067 mm	42"	564 kg	1,244 lb	6	X	Y	Y
Komatsu "H" Series SD	0.34 m ³	0.44 yd ³	610 mm	24"	441 kg	972 lb	4	V	V	V
	0.45 m ³	0.59 yd ³	762 mm	30"	509 kg	1,122 lb	5	V	V	W
	0.56 m ³	0.73 yd ³	914 mm	36"	581 kg	1,280 lb	5	W	X	Y
	0.67 m ³	0.88 yd ³	1067 mm	42"	652 kg	1,437 lb	6	X	Y	Z

V – Used with weights up to 3,500 lb/yd³, W – Used with weights up to 3,000 lb/yd³
 X – Used with weights up to 2,500 lb/yd³, Y – Used with weights up to 2,000 lb/yd³, Z – Not useable



OPTIONAL EQUIPMENT

- Boom 4600 mm 15'1" with actuator piping
- Alternator, 60A
- Arm, 3000 mm 9'10"
- Arm, 2100 mm 6'11"
- Arm, 2500 mm 8'2"
- Arm, 2500 mm 8'2" with actuator piping
- Blade assembly
- Hydraulic control unit
 - 1 additional actuator
 - 2 additional actuators
- Pattern change valve
- Shoes
 - 500 mm 20" triple grouser
 - 700 mm 28" triple grouser
- Track roller guard
- Track frame undercover
- Rain visor
- Sun visor



LIFTING CAPACITY

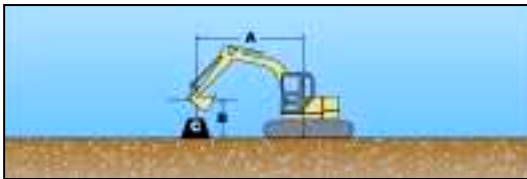

Equipment:

- Boom: 4.6 m 15'1"
- Bucket: 0.35 m³ 0.46 yd³
- Counterweight: 3420 kg 7,540 lb

- A: Reach from swing circle
- B: Bucket hook height
- C: Lifting capacity
- Cf: Rating over front
- Cs: Rating over side
- ☉: Rating at maximum reach

PC138USLC-2		Arm: 2100 mm 6'11"						Unit: kg lb	
B	A	3.0 m 10'		4.5 m 15'		6.0 m 20'		☉ Maximum	
		Cf	Cs	Cf	Cs	Cf	Cs	Cf	Cs
6.0 m 20'				*3340 *7,370	*3340 *7,370			*2250 *4,980	*2250 *4,980
3.0 m 10'		*5800 *12,800	*5800 *12,800	*4120 *9,900	3210 7,080	3330 7,360	1970 4,350	*2060 *4,550	1530 3,380
0.0 m 0'		*6160 *13,580	5110 11,270	*4960 *10,940	2770 6,110	3140 6,920	1790 3,960	2460 5,440	3170 1,440
-3.0 m -10'		*6000 *13,240	5200 11,460	4100 9,040	2740 6,040			2960 6,530	2100 4,640

PC138USLC-2		Arm: 2500 mm 8'2"						Unit: kg lb	
B	A	3.0 m 10'		4.5 m 15'		6.0 m 20'		☉ Maximum	
		Cf	Cs	Cf	Cs	Cf	Cs	Cf	Cs
6.0 m 20'								*1820 *4,020	*1820 *4,020
3.0 m 10'		*5170 *11,390	*5170 *11,390	*3850 *8,490	3280 7,240	3230 7,130	2010 4,440	*1680 *3,720	1400 3,100
0.0 m 0'		6830 15,060	5200 11,480	*4910 *10,910	2760 6,080	3160 6,960	1810 3,990	*2000 *4,420	1320 2,910
-3.0 m -10'		*6620 *14,600	5160 11,390	4430 9,780	2670 5,900			2900 6,400	1830 4,050

PC138USLC-2		Arm: 3000 mm 9'10"						Unit: kg lb	
B	A	3.0 m 10'		4.5 m 15'		6.0 m 20'		☉ Maximum	
		Cf	Cs	Cf	Cs	Cf	Cs	Cf	Cs
6.0 m 20'				*2530 *5,580	*2530 *5,580	*2230 *4,920	2110 4,660	*1440 *3,190	*1440 *3,190
3.0 m 10'		*3560 *7,860	*3560 *7,860	*3440 *7,590	3350 7,390	*2980 *6,580	2040 4,500	*1340 *2,960	1230 2,720
0.0 m 0'		*7760 *17,120	5270 11,630	5030 11,100	2830 6,240	3150 6,960	1800 3,980	*1560 *3,450	1150 2,550
-3.0 m -10'		*7180 *15,830	5070 11,180	4770 10,510	2660 5,870	3070 6,770	1730 3,810	2440 5,390	1530 3,390

* Load is limited by hydraulic capacity rather than tipping. Ratings are based on ISO Standard No. 10567. Rated loads do not exceed 87% of hydraulic lift capacity or 75% of tipping load.

AESS658-00

©2004 Komatsu Printed in USA

DK04(7.5M) C

04/04 (EV-1)

KOMATSU®

440 N. Fairway Drive
P.O. Box 8112
Vernon Hills, IL 60061-8112

