

KOMATSU®

PC200LC-7

FLYWHEEL HORSEPOWER
107 kW **143 HP** @ 1950 rpm

OPERATING WEIGHT
20430–21260 kg
45,040–46,870 lb

BUCKET CAPACITY
0.48–1.53 m³ **0.65–2.0 yd³**

PC
200
LC

HYDRAULIC EXCAVATOR



Photo may include optional equipment.

GALEO

WALK-AROUND

Productivity Features

- ***High Production and Low Fuel Consumption***

Production is increased with larger output during Active mode while fuel efficiency is further improved.

- ***Maximum Digging Height is 10 m 32'10"***, a benefit in jobs requiring a longer reach

Easy Maintenance

- Replacement interval is extended for engine oil, engine oil filter and hydraulic filter
- Remote mounted engine oil filter and fuel drain valve for easy access
- Water separator is standard equipment
- Easier radiator cleaning
- Fuel tank capacity is increased
- SCSH bushings on work equipment extend lubricating interval from 100 hours to 500 hours (excluding bucket)

Simplified Maintenance

- The replacement interval of the new hydraulic filter is 1,000 hours

- ***Bucket Digging Power Is Increased 29%***

over the PC200LC-6

- ***Higher Lifting Capacity***

PC200LC-7's lateral stability is improved, and lifting capacity is also increased.



Harmony with Environment

- Low emission engine
A powerful turbocharged and air to air aftercooled Komatsu SAA6D102E-2 provides 107 kW **143 HP**. This engine is EPA, EU, and Japan Tier 2 emissions certified without sacrificing power or machine productivity
- Economy mode improves fuel consumption
- Low operating noise

Large Comfortable Cab

PC200LC-7's cab volume is increased by 14%, over the PC200LC-6 offering an exceptionally roomy operating environment.

- Highly pressurized cab with air conditioner
- Low noise design
- Low vibration with cab damper mounting

FLYWHEEL HORSEPOWER

107 kW **143 HP** @ 1950 rpm

OPERATING WEIGHT

20430–21260 kg

45,040–46,870 lb

BUCKET CAPACITY

0.48–1.53 m³

0.65–2.0 yd³

***Excellent Reliability and Durability***

- High rigidity work equipment
- Sturdy frame structure
- Reliable Komatsu manufactured major components
- Highly reliable electronic devices

GALEO

Komatsu's highly productive, innovative technology, environmentally friendly machines built for the 21st century.

PRODUCTIVITY FEATURES

High Production and Low Fuel Consumption

Engine

The PC200LC-7 gets its exceptional power and work capacity from a Komatsu SAA6D102E-2 engine. Output is 107 kW **143 HP**, providing increased hydraulic power and improved fuel efficiency.

Hydraulics

Unique two-pump system ensures smooth compound movement of the work equipment. HydraMind controls both pumps for efficient engine power use. This system also reduces hydraulic loss during operation.

Large Digging Height

PC200LC-7's maximum digging height is 10 m **32'10"**, facilitating jobs that require a longer reach, such as demolition and slope finishing.

Four Working Modes

Working Mode Selection

The PC200LC-7 excavator is equipped with four working modes (**A, E, B** and **L** mode). Each mode is designed to match engine speed, pump output, and system pressure with the current application. This provides the flexibility to match equipment performance to the job at hand.

Economy Mode

Economy mode is environmentally friendly. Fuel consumption is reduced 20% (compared with PC200LC-7 Active mode) and production is equal to the PC200LC-6 Heavy-duty mode.

Power Max Function

This function temporarily increases digging force by 7% for added power in tough situations.

Lifting Mode

When the Lifting mode is selected, lifting capacity is increased by 7% by raising hydraulic pressure.

Larger Digging Power Provides Increased Production

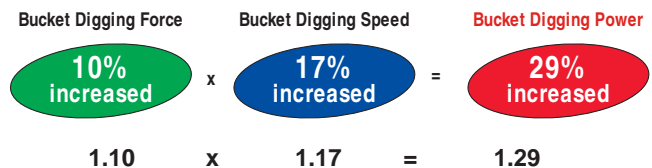

Bucket Digging Power is obtained by bucket digging force x bucket digging speed. New PC200LC-7 bucket digging force is increased by 10% and bucket digging speed is increased by 17%, the resulting total bucket digging power is increased 29% (bucket digging force compared with PC200LC-6). The digging force and speed generated result in the largest digging power and the largest production in the 20 ton **22 U.S. ton** class.

Bucket Digging Force*: SAE 138 kN 14100 kg **31,080 lb**
 ISO 149 kN 15200 kg **33,510 lb**
 Arm Crowd Force*: SAE 101 kN 10300 kg **22,710 lb**
 ISO 108 kN 11000 kg **24,250 lb**

*Measured with Power Max function, 2925 mm **9'7"** arm

Working Mode	Application	Advantage
A	Active mode	<ul style="list-style-type: none"> Maximum production/power Fast cycle times
E	Economy mode	<ul style="list-style-type: none"> Excellent fuel economy
L	Lifting mode	<ul style="list-style-type: none"> Hydraulic pressure is increased by 7%
B	Breaker operation	<ul style="list-style-type: none"> Optimum engine rpm, hydraulic flow

Automatic Three-Travel Speed

Travel speed is automatically shifted from high to low speed according to the pressure required to travel.

	High	Mid	Low
Travel Speed	5.5 km/h 3.4 mph	4.1 km/h 2.5 mph	3.0 km/h 1.9 mph

Multi-Function Color Monitor

A newly developed Multi-Function Color Monitor has multiple functions, such as Working mode selection, hydraulic pump oil flow adjustment for matching to attachment, and maintenance interval notice, etc.

Working Mode Selection

The Multi-Function Color Monitor allows for easy selection of the working modes (A, E, B and L modes).

Automatic Three-Travel Speed

Travel speed is automatically shifted from high to low speed according to the pressure required to travel.

EMMS (Equipment Management Monitoring System)

Monitor Function

Controller monitors engine oil level, coolant temperature, battery charge and air clogging, etc. If the controller finds any abnormality, it is displayed.

Maintenance Function

The monitor informs replacement time of oil, filters and other maintenance items when the designated interval is reached.

Trouble Data Memory Function

The monitor stores machine abnormalities for effective troubleshooting.



Excellent Reliability and Durability

● High Rigidity Work Equipment

The arm and boom are strengthened to correspond to increased bucket and arm digging forces. The arm and boom cross sectional strength are increased 31% and 4% respectively. The boom and arm have large cross-sectional dimensions as well as continuous groove welding, improving digging and side-contact strength.

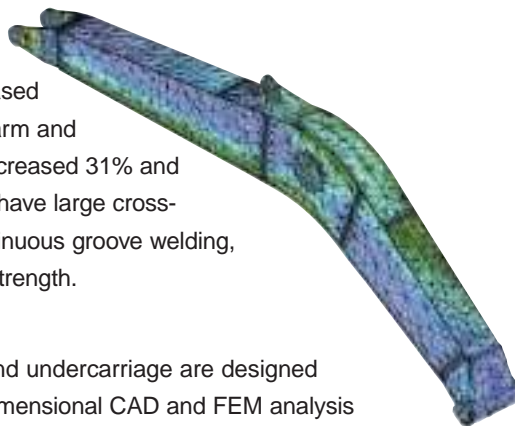

● Sturdy Frame Structure

The revolving frame, center frame and undercarriage are designed by using the most advanced three-dimensional CAD and FEM analysis technology.

● Reliable Components

All of the major machine components, such as engine, hydraulic pumps, hydraulic motors and control valves, etc., are exclusively designed and manufactured by Komatsu.

● Highly Reliable Electronic Devices

Exclusively designed electronic devices have passed severe testing.

- Controller
- Sensors
- Connectors
- Heat resistant wiring

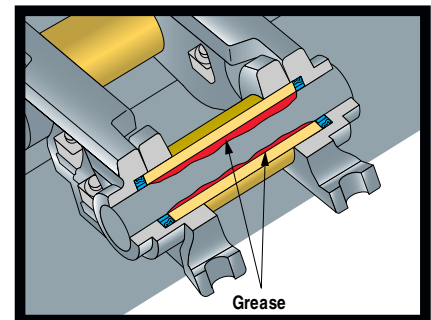

Grease Sealed Track provides excellent undercarriage durability



Track Link with Strut

PC200LC-7 uses track links with strut providing superb durability

WORKING ENVIRONMENT

PC200LC-7 cab interior is spacious and provides a comfortable working environment...

Large Comfortable Cab

Comfortable Cab

New PC200LC-7's cab volume is increased by 14%, offering an exceptionally comfortable operating environment. The large cab permits full flat reclining of the seat back.

Pressurized Cab

The air conditioner, air filter and a higher internal air pressure (6.0 mm Aq **0.2" Aq**) prevent external dust from entering the cab.

Low Noise Design

Noise level is remarkably reduced, not only engine noise but also noise when swinging and hydraulic relief.

Low Vibration with Cab Damper Mounting

PC200LC-7 uses new, improved multi-layer viscous mount system that incorporates longer stroke and the addition of a spring. The new cab damper mounting combined with strengthened left and right side decks aids vibration reduction at the operator's seat.

Vibration at floor is reduced from 120 dB (VL) to 115 dB (VL).

dB (VL) is index for expressing size of vibration.

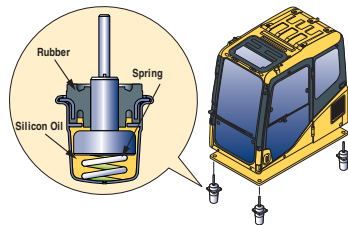

Comparison of Riding Comfort

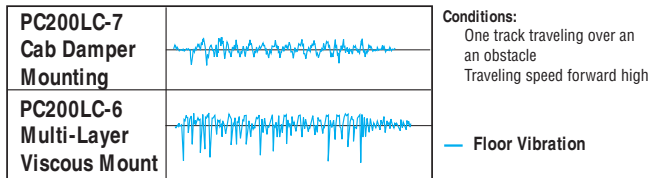

Pitch vertical direction on graph shows size of vibration.



Skylight



Sliding Window



Washable Cab Floor mat
 The PC200LC-7's cab floor mat is easy to keep clean. The gently inclined surface has a flanged floor mat and drainage holes to facilitate runoff.

SAFETY FEATURES



Photo may include optional equipment.

Safety Features

Wide Visibility

The right side window pillar has been removed and the rear pillar reshaped to provide better visibility. Blind spots have been decreased by 34%.

Pump/engine room partition

prevents oil from spraying on the engine if a hydraulic hose should burst.

Thermal and fan guards are placed around high-temperature parts of the engine and fan drive.

Steps with non-skid sheet and large handrail. Steps with non-skid sheet provide anti-slip footing for maintenance.

Multi-Position Controls

The multi-position, pressure proportional control levers allow the operator to work in comfort while maintaining precise control. A double-slide mechanism allows the seat and controllers to move together or independently, allowing the operator to position the controllers for maximum productivity and comfort.



Seat Sliding Amount: 340 mm
13.4", increased 120 mm 4.7"



Large Handrail



Thermal Guard



Defroster



Cab Frame Mounted Wiper



Bottle Holder and
Magazine Rack

MAINTENANCE FEATURES

Easy Maintenance

Komatsu designed the PC200LC-7 to have easy service access. We know by doing this, routine maintenance and servicing are less likely to be skipped, which can mean a reduction in costly downtime later on. Here are some of the many service features found on the PC200LC-7.

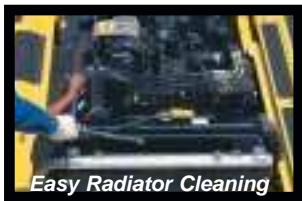

- Easy Radiator Cleaning**
 Clearance between radiator and oil cooler is increased to facilitate radiator core cleaning with an air nozzle.

- Water Separator** is standard equipment, removing water mixed in fuel and preventing fuel system damage.

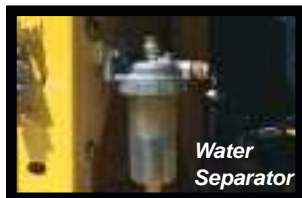

- Easy Access to Engine Oil Filter and Fuel Drain Valve.** Engine oil filter and fuel drain valve are remotely mounted to improve accessibility.

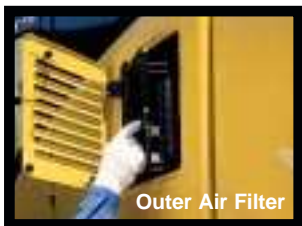

Removal and installation of air conditioner filter element, without tools, facilitates cleaning.

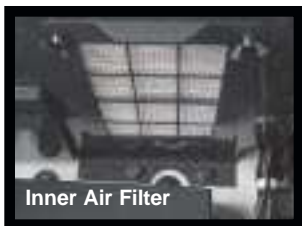

- Easy Cab Filter Maintenance**
 Tool free removal of the internal and external cab filters.

- Fuel Tank Capacity Increased**
 Fuel tank capacity is increased from 340 ltr **89.8 U.S. gal** to 400 ltr **105.7 U.S. gal** to extend operating hours before refueling. The fuel tank is treated for rust prevention and improved corrosion resistance.

Reducing Maintenance Costs

- Hydraulic Oil and Filter/Engine Oil and Filter Replacement Interval Extended**

The new high performance filters are used in the hydraulic circuit and engine. Hydraulic oil filter, engine oil, and engine oil filter element replacement intervals are significantly extended to reduce maintenance costs.

Comparison of Replacement Intervals unit: hours

	PC200LC-7	PC200LC-6
Engine oil	500	250
Engine oil filter	500	250
Hydraulic oil	5,000	5,000
Hydraulic oil filter	1,000	500

All Work Equipment Lubrication Intervals are 500 Hours with SCSH Bushings (Excluding Bucket)

Newly developed SCSH bushings are used on bucket and arm top bushing; end faces are injected with Tungsten Carbide. All bushing lubrication intervals of work equipment are extended from 100 hours to 500 hours (excluding the bucket) reducing maintenance costs.

SCSH (Steel Copper Sinter Hard Material) bushing

is based on ferrous powder metallurgy (carbonized treatment). It contains a special lubricant in pores, and the hard particles are diffused to improve durability for wear and scratching.

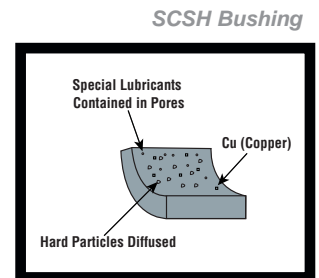

Tungsten Carbide Injected Bushing

Tungsten Carbide is injected into the end faces of the arm top bushing to form a hard film, reducing wear of contacting surfaces and fluttering of the bucket.

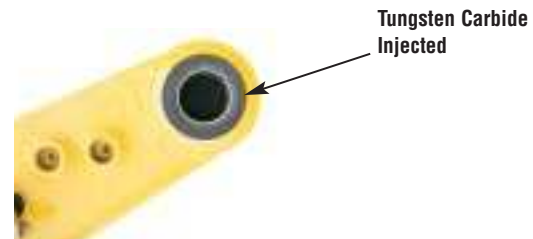

SPECIFICATIONS



ENGINE

Model Komatsu SAA6D102E-2
 Type Water-cooled, 4-cycle, direct injection
 Aspiration Turbocharged and air-air aftercooling
 Number of cylinders 6
 Bore 102 mm **4.02"**
 Stroke 120 mm **4.72"**
 Piston displacement 5.88 ltr **359 in³**
 Power rating (*SAE J1995 conditions)
 *Gross **150 HP** 111.9 kW @ 1950 rpm
 Flywheel **143 HP** 106.6 kW @ 1950 rpm
 Governor All-speed control, mechanical
 Meets 2003 EPA Tier 2 emission regulations.



HYDRAULICS

Type ... HydrauMind (Hydraulic Mechanical Intelligence New Design) system, closed-center system with load sensing valves and pressure compensated valves
 Number of selectable working modes 4
 Main pump:
 Type Variable displacement piston type
 Pumps for Boom, arm, bucket, swing, and travel circuits
 Maximum flow 428 ltr/min **113 U.S. gal/min**
 Supply for control circuit Self-reducing valve
 Hydraulic motors:
 Travel 2 x axial piston motor with parking brake
 Swing 1 x axial piston motor with swing holding brake
 Relief valve setting:
 Implement circuits 37.3 MPa 380 kgf/cm² **5,400 psi**
 Travel circuit 37.3 MPa 380 kgf/cm² **5,400 psi**
 Swing circuit 28.9 MPa 290 kgf/cm² **4,125 psi**
 Pilot circuit 3.2 MPa 33 kgf/cm² **470 psi**
 Hydraulic cylinders:
 (Number of cylinders – bore x stroke x rod diameter)
 Boom 2–130 mm x 1334 mm x 90 mm **5.1" x 52.5" x 3.5"**
 Arm 1–135 mm x 1490 mm x 95 mm **5.3" x 58.7" x 3.7"**
 Bucket 1–115 mm x 1120 mm x 80 mm **4.5" x 44.1" x 3.2"**



DRIVES AND BRAKES

Steering control Two levers with pedals
 Drive method Hydrostatic
 Maximum drawbar pull 178 kN 18200 kg **40,120 lb**
 Gradeability 70%, 35°
 Maximum travel speed: High 5.5 km/h **3.4 mph**
 (Auto-Shift) Mid 4.1 km/h **2.5 mph**
 Low 3.0 km/h **1.9 mph**
 Service brake Hydraulic lock
 Parking brake Mechanical disc brake



SWING SYSTEM

Drive method Hydrostatic
 Swing reduction Planetary gear
 Swing circle lubrication Grease-bathed
 Service brake Hydraulic lock
 Holding brake/Swing lock Mechanical disc brake
 Swing speed 12.4 rpm
 Swing torque 6656 kg•m **48,124 ft lbs**



UNDERCARRIAGE

Center frame X-frame
 Track frame Box-section
 Seal of track Sealed track
 Track adjuster Hydraulic
 Number of shoes (each side): 49
 Number of carrier rollers 2 each side
 Number of track rollers (each side): 9



COOLANT AND LUBRICANT CAPACITY (REFILLING)

Fuel tank 400 ltr **105.7 U.S. gal**
 Coolant 22.4 ltr **5.9 U.S. gal**
 Engine 24.0 ltr **6.3 U.S. gal**
 Final drive, each side 4.5 ltr **1.2 U.S. gal**
 Swing drive 6.6 ltr **1.7 U.S. gal**
 Hydraulic tank 143 ltr **37.8 U.S. gal**



OPERATING WEIGHT (APPROXIMATE)

Operating weight including 5700 mm **18'8"** one-piece boom, 2925 mm **9'7"** arm, SAE heaped 0.80 m³ **1.05 yd³** backhoe bucket, rated capacity of lubricants, coolant, full fuel tank, operator, and standard equipment.

Shoes	PC200LC-7	
	Operating Weight	Ground Pressure
700 mm 28"	20700 kg 45,640 lb	36.3 kPa 0.37 kgf/cm ² 5.26 psi
800 mm 31.5"	21050 kg 46,410 lb	33.3 kPa 0.34 kgf/cm ² 4.85 psi

PC200LC-7 HYDRAULIC EXCAVATOR



DIMENSIONS

	Arm Length	2410 mm	7'11"	2925 mm	9'7"
A	Overall length	9495 mm	31'2"	9425 mm	30'11"
B	Length on ground (transport):	5885 mm	19'4"	5000 mm	16'5"
C	Overall height (to top of boom)	3190 mm	10'6"	2970 mm	9'9"
D	Overall width	3180 mm	10'5"		
E	Overall height (to top of cab)	3000 mm	9'10"		
F	Ground clearance, counterweight	1085 mm	3'7"		
G	Ground clearance (minimum)	440 mm	1'5"		
H	Tail swing radius	2750 mm	9'0"		
I	Track length on ground	3640 mm	11'11"		
J	Track length	4450 mm	14'7"		
K	Track gauge	2380 mm	7'10"		
L	Width of crawler	3180 mm	10'5"		
M	Shoe width	800 mm	31.5"		
N	Grouser height	26 mm	1.0"		
O	Machine cab height	2095 mm	6'10"		
P	Machine cab width	2710 mm	8'11"		
Q	Distance, swing center to rear end	2710 mm	8'11"		

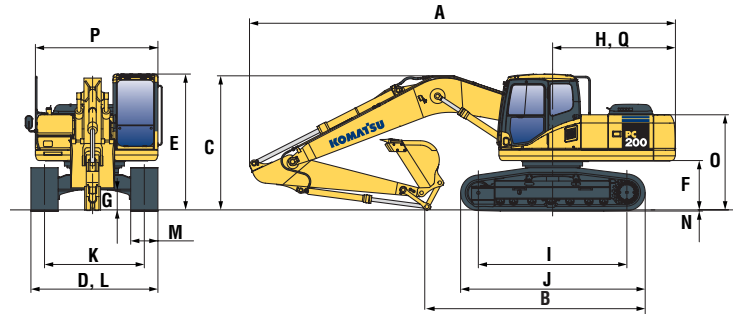

WORKING RANGE

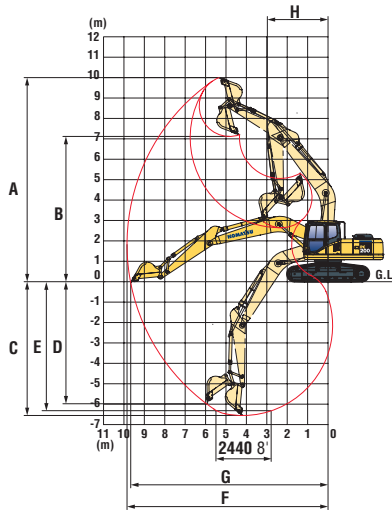

	Arm	2410 mm	7'11"	2925 mm	9'7"
A	Max. digging height	9800 mm	32'2"	10000 mm	32'10"
B	Max. dumping height	6890 mm	22'7"	7110 mm	23'4"
C	Max. digging depth	6095 mm	20'0"	6620 mm	21'9"
D	Max. vertical wall digging depth	5430 mm	17'10"	5980 mm	19'7"
E	Max. digging depth of cut for 8' level	5780 mm	19'0"	6370 mm	20'11"
F	Max. digging reach	9380 mm	30'9"	9875 mm	32'5"
G	Max. digging reach at ground level	9190 mm	30'2"	9700 mm	31'10"
H	Min. swing radius	3090 mm	10'2"	3040 mm	10'0"
SAE rating	Bucket digging force at power max.	138 kN		138 kN	
	Arm crowd force at power max.	14100 kgf/31,080 lb		101 kN	10300 kgf/22,710 lb
ISO rating	Bucket digging force at power max.	149 kN		149 kN	
	Arm crowd force at power max.	15200 kgf/33,510 lb		127 kN	13000 kgf/28,660 lb



BACKHOE BUCKET, ARM, AND BOOM COMBINATION

Bucket Type	Bucket				Arms		
	Capacity	OLW	Weight	Number of Teeth	7'11"	9'7"	
Komatsu "H" Series HD	0.50 m ³ 0.66 yd ³	610 mm 24"	639 kg 1,409 lb	3	V	V	
	0.67 m ³ 0.88 yd ³	762 mm 30"	679 kg 1,497 lb	4	V	V	
	0.86 m ³ 1.13 yd ³	914 mm 36"	767 kg 1,690 lb	4	V	V	
	1.04 m ³ 1.36 yd ³	1067 mm 42"	842 kg 1,856 lb	5	V	V	
	1.22 m ³ 1.59 yd ³	1219 mm 48"	910 kg 2,007 lb	6	W	X	
	1.38 m ³ 1.80 yd ³	1219 mm 48"	962 kg 2,121 lb	6	X	Y	
Komatsu "H" Series SD	0.50 m ³ 0.66 yd ³	610 mm 24"	655 kg 1,445 lb	3	V	V	
	0.65 m ³ 0.85 yd ³	762 mm 30"	717 kg 1,580 lb	4	V	V	
	0.83 m ³ 1.08 yd ³	914 mm 36"	792 kg 1,745 lb	4	V	V	
	0.99 m ³ 1.30 yd ³	1067 mm 42"	895 kg 1,973 lb	5	V	W	
	1.16 m ³ 1.52 yd ³	1219 mm 48"	1036 kg 2,283 lb	6	W	X	

V – Used with weights up to 3,500 lb/yd³, W – Used with weights up to 3,000 lb/yd³

X – Used with weights up to 2,500 lb/yd³, Y – Used with weights up to 2,000 lb/yd³, Z – Not useable



LIFTING CAPACITY

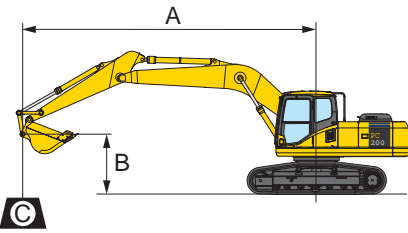

- A: Reach from swing center
- B: Bucket hook height
- C: Lifting capacity
- Cf: Rating over front
- Cs: Rating over side
- ⊙: Rating at maximum reach

Conditions:

- Arm: 2925 mm **9'7"**
- Boom length 5700 mm **18'8"**
- Bucket 0.8 m³ **1.05 yd³** (SAE heaped)
–Bucket weight: 628 kg **1,385 lb.**

PC200LC-7												Shoe: 700 mm 28" triple grouser	
B \ A	1.5 m 5'		3.0 m 10'		4.6 m 15'		6.1 m 20'		7.6 m 25'		⊙ MAX		
	Cf	Cs	Cf	Cs	Cf	Cs	Cf	Cs	Cf	Cs	Cf	Cs	
7.6 m 25'							*3800 kg *8,300 lb	*3800 kg *8,300 lb			*2750 kg *6,100 lb	*2750 kg *6,100 lb	
6.1 m 20'							*5200 kg *11,500 lb	4600 kg 10,200 lb			*2600 kg *5,800 lb	*2600 kg *5,800 lb	
4.6 m 15'							*6000 kg *13,300 lb	4500 kg 9,900 lb	*4650 kg *10,250 lb	3000 kg 6,600 lb	*2650 kg *5,800 lb	2550 kg 5,600 lb	
3.0 m 10'			*13650 kg *30,100 lb	13300 kg 29,300 lb	*8900 kg *19,700 lb	6800 kg 14,900 lb	6950 kg 15,300 lb	4250 kg 9,400 lb	4750 kg 10,500 lb	2900 kg 6,400 lb	*2800 kg *6,100 lb	2300 kg 5,100 lb	
1.5 m 5'			*7500 kg *16,500 lb	*7500 kg *16,500 lb	10850 kg 23,900 lb	6250 kg 13,800 lb	6650 kg 14,700 lb	4000 kg 8,800 lb	4650 kg 10,250 lb	2800 kg 6,100 lb	*3050 kg *6,700 lb	2200 kg 4,800 lb	
0 m 0'			*8000 kg *17,700 lb	*8000 kg *17,700 lb	10400 kg 23,000 lb	5900 kg 13,000 lb	6450 kg 14,200 lb	3800 kg 8,350 lb	4500 kg 10,000 lb	2700 kg 5,900 lb	*3500 kg *7,800 lb	2250 kg 4,900 lb	
-1.5 m -5'	*6800 kg *15,000 lb	*6800 kg *15,000 lb	*11200 kg *24,700 lb	*11200 kg *24,700 lb	10250 kg 22,600 lb	5750 kg 12,700 lb	6350 kg 14,000 lb	3700 kg 8,200 lb	4450 kg 9,900 lb	2650 kg 5,800 lb	4150 kg *9,200 lb	2450 kg 5,400 lb	
-3.0 m -10'	*10550 kg *23,200 lb	*10550 kg *23,200 lb	*16050 kg *35,400 lb	11450 kg 25,300 lb	10300 kg 22,700 lb	5800 kg 12,700 lb	6350 kg 14,000 lb	3700 kg 8,200 lb			4950 kg 10,900 lb	2950 kg 6,500 lb	
-4.6 m -15'			*15800 kg *34,900 lb	11850 kg 26,100 lb	10500 kg 23,100 lb	5950 kg 13,100 lb					7050 kg 15,500 lb	4150 kg 9,200 lb	

* Load is limited by hydraulic capacity rather than tipping. Ratings are based on iso Standard No. 10567. Rated loads do not exceed 87% of hydraulic lift capacity or 75% of tipping load.

PC200LC-7												Shoe: 800 mm 31.5" triple grouser	
B \ A	1.5 m 5'		3.0 m 10'		4.6 m 15'		6.1 m 20'		7.6 m 25'		⊙ MAX		
	Cf	Cs	Cf	Cs	Cf	Cs	Cf	Cs	Cf	Cs	Cf	Cs	
7.6 m 25'							*3800 kg *8,300 lb	*3800 kg *8,300 lb			*2750 kg *6,100 lb	*2750 kg *6,100 lb	
6.1 m 20'							*5200 kg *11,500 lb	*4700 kg *10,300 lb			*2600 kg *5,800 lb	*2600 kg *5,800 lb	
4.6 m 15'							*6000 kg *13,300 lb	4550 kg 10,000 lb	4650 kg 10,250 lb	3050 kg 6,700 lb	*2650 kg *5,800 lb	2600 kg 5,700 lb	
3.0 m 10'			*13650 kg *30,100 lb	*13450 kg *29,700 lb	*8900 kg *19,700 lb	6850 kg 15,100 lb	*7050 kg *15,500 lb	4300 kg 9,500 lb	4850 kg 10,700 lb	2950 kg 6,500 lb	*2800 kg *6,100 lb	2350 kg 5,100 lb	
1.5 m 5'			*7500 kg *16,500 lb	*7500 kg *16,500 lb	11000 kg 24,200 lb	6300 kg 13,900 lb	6750 kg 14,900 lb	4050 kg 9,000 lb	4700 kg 10,400 lb	2800 kg 6,200 lb	*3050 kg *6,700 lb	2250 kg 4,900 lb	
0 m 0'			*8000 kg *17,700 lb	*8000 kg *17,700 lb	10550 kg 23,300 lb	5950 kg 13,200 lb	6550 kg 14,500 lb	3850 kg 8,500 lb	4600 kg 10,100 lb	2750 kg 6,000 lb	3500 kg 7,800 lb	2250 kg 4,900 lb	
-1.5 m -5'	*6800 kg *15,000 lb	*6800 kg *15,000 lb	*11200 kg *24,700 lb	11200 kg 24,700 lb	10400 kg 22,900 lb	5850 kg 12,900 lb	6450 kg 14,200 lb	3750 kg 8,300 lb	4550 kg 10,000 lb	2700 kg 5,900 lb	4200 kg *9,300 lb	2500 kg 5,500 lb	
-3.0 m -10'	*10550 kg *23,200 lb	*10550 kg *23,200 lb	*16050 kg *35,400 lb	11600 kg 25,600 lb	10450 kg 23,000 lb	5850 kg 12,900 lb	6450 kg 14,200 lb	3800 kg 8,350 lb			5050 kg 11,100 lb	3000 kg 6,600 lb	
-4.6 m -15'			*15800 kg *34,900 lb	12000 kg 26,400 lb	10650 kg 23,500 lb	6050 kg 13,300 lb					7150 kg 15,800 lb	4200 kg 9,300 lb	

* Load is limited by hydraulic capacity rather than tipping. Ratings are based on ISO Standard No. 10567. Rated loads do not exceed 87% of hydraulic lift capacity or 75% of tipping load.



STANDARD EQUIPMENT

- Air conditioner with defroster
- Alternator, 50 Ampere, 24V
- Auto-Decel
- Automatic deaeration system for fuel line
- Automatic engine warm-up system
- Batteries, large capacity
- Boom and arm holding valve
- Cab
- Counterweight
- Dry type air cleaner, double element
- Electric horn
- Engine, Komatsu SAA6D102E-2
- Engine overheat prevention system
- Fan guard structure
- High pressure hydraulic filters
- Hydraulic track adjusters (each side)
- Multi-function color monitor
- Power maximizing system
- PPC hydraulic control system
- Radiator and oil cooler dustproof net
- Rearview mirror, RH, LH
- Seat belt, retractable 76 mm 3"
- Seat, suspension
- Service valve
- Shoes, triple grouser: 800 mm 31.5"
- Starting motor, 4.5 kW/24V x 1
- Track guiding guard, center section
- Travel alarm
- Working light, 2 (boom and RH)
- Working mode selection system



OPTIONAL EQUIPMENT

- Arms
 - 2925 mm 9'7" arm assembly
 - 2925 mm 9'7" HD arm assembly with piping
 - 2410 mm 7'11" arm assembly
- Boom
 - 5700 mm 18'8" boom
 - 5700 mm 18'8" HD boom with piping
- Cab front and top guards
- Converter, 12V
- High Ambient Temperature Spec.
- Pattern change valve
- Rain visor
- Shoes, triple grouser: 700 mm 28"
- Straight travel pedal
- Sun visor
- Track frame undercover
- Track roller guards (full length)



ATTACHMENT OPTIONS

- Buckets
 - Lug bushing
 - Play adjustment mechanism
- Komatsu breakers/hammers
- Komatsu plate compactors
- Lincoln autolube systems
- JRB couplers
- PSM thumbs

For a complete line up of available attachments, please contact your local Komatsu distributor

AESS587-04

©2004 Komatsu Printed in USA

DK03(7.5M) C

03/04(EV-3)

KOMATSU®

440 N. Fairway Drive
P.O. Box 8112
Vernon Hills, IL 60061-8112

