

KOMATSU®

PC210LCi-10

Tier 4 Interim Engine

PC210LCi

NET HORSEPOWER

158 HP @ 2000rpm
118 kW @ 2000rpm

OPERATING WEIGHT

48,950–52,036 lb
22203–23603 kg

BUCKET CAPACITY

0.66–1.57 yd³
0.50–1.20 m³



PHOTOS MAY INCLUDE OPTIONAL EQUIPMENT

intelligent
MACHINE CONTROL

PC210LCi

WALK-AROUND

PC210LCi-10



Photos may include optional equipment

PC210LCi-10

Tier 4 Interim Engine

NET HORSEPOWER

158 HP @ 2000rpm
118 kW @ 2000rpm

OPERATING WEIGHT

48,950–52,036 lb
22203–23603 kg

BUCKET CAPACITY

0.66–1.57 yd³
0.50–1.20 m³



MAKE EVERY PASS COUNT

Improve your efficiency – less time required to complete excavation to finish grade with intelligent Machine Control (see pg 5).

Semi-automatic operation – next generation technology goes beyond traditional machine guidance (indicate only) type systems.

Innovative

- World's first intelligent Machine Control excavator, features semi-automatic operation of work equipment for highly accurate work.
- Large 12.1" (30.7 cm) monitor neatly displays simultaneously information such as magnified fine grading view, 3D view, current as-built status, etc.

Integrated

- Complete factory installed integrated intelligent Machine Control system comes standard with stroke sensing hydraulic cylinders, Global Navigation Satellite System (GNSS) components and an Inertial Measurement Unit (IMU) sensor. All components are validated to Komatsu's rigid quality & durability standards.

Intelligent

- intelligent Machine Control excavator allows the operator to focus on moving material efficiently while semi-automatically tracing the target surface and limiting over-excavation.
- Facing angle compass, light bar and sound guidance aid in ease of operation and bucket positioning.



Photos may include optional equipment



Photos may include optional equipment

intelligent Machine Control

intelligent Machine Control is based on Komatsu's unique sensor package, including stroke sensing hydraulic cylinders, an IMU sensor, and GNSS antennas. It utilizes 3D design data loaded in the control box to accurately check its position against the target. If the bucket hits the target surface,

it is semi-automatically limited to minimize over-excavation. If the operator turns off Auto mode, the machine can be operated with highly accurate, responsive machine guidance (indicate only).



• Auto grade assist

With the auto grade assist function, the operator moves the arm, the boom adjusts the bucket height automatically, tracing the target surface and minimizing digging too deep. This allows the operator to perform rough digging without worrying about the design surface, and to perform fine digging by operating the arm lever only. The working range is expanded by holding the lever to move the boom downward.



• Auto stop control

During boom or bucket operation, the work equipment automatically stops when the bucket edge reaches the design surface, thus minimizing damage to the design surface.

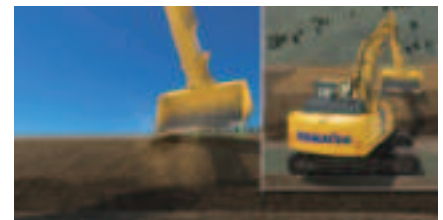

• Minimum distance control

The intelligent Machine Control excavator controls the bucket by automatically selecting the point on the bucket closest to the target surface. Should the machine not be facing a sloped surface at a right angle, it will still follow the target surface and minimize digging below it.

Improved Construction Efficiency

Staking, survey and final inspection which is usually done manually, can be reduced with the intelligent Machine Control excavator by setting 3D design data on the control box. Also, use of the facing angle compass can minimize leveling work for the surface on which the machine sits. Even if the machine is inclined while working, the facing angle compass allows the operator to ensure that the machine is facing perpendicular to the target surface. The intelligent Machine Control technology allows the operator to improve work efficiency (i.e. shorter construction time) while minimizing over-excavating the target surface from rough digging to finish grading.

Comparison of construction time based on in-house test of excavation and grading slope surface

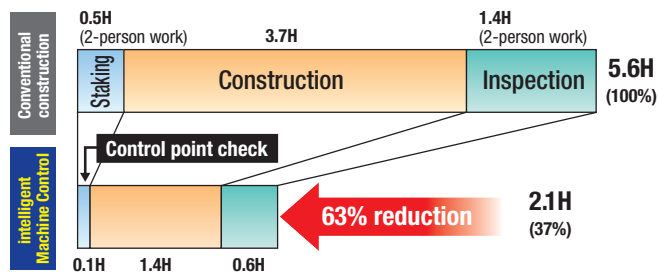

* When used by an expert operator, the Komatsu intelligent Machine Control system increases construction efficiency.
 * The above data does not include design time or working data creation time. The above data are based on in-house construction tests whose conditions may differ from actual construction.



Comparison of slope shaping work

Conventional construction

Shaping with reference to finishing stakes



intelligent Machine Control

Reduces staking work and the number of assistant workers.



Improved Work Accuracy

The bucket edge/tip position is instantly displayed on the control box, eliminating the wait time for display on the monitor during construction. The large and easy-to-view control box displays information clearly, aiding in highly accurate work. With manual operation and conventional machine guidance, finish grade quality and excavating accurately depends heavily on the skill of the operator. With the intelligent Machine Control excavator, the bucket is automatically limited to follow the target grade without over-excavating.

Relationship between finished surface and allowable value

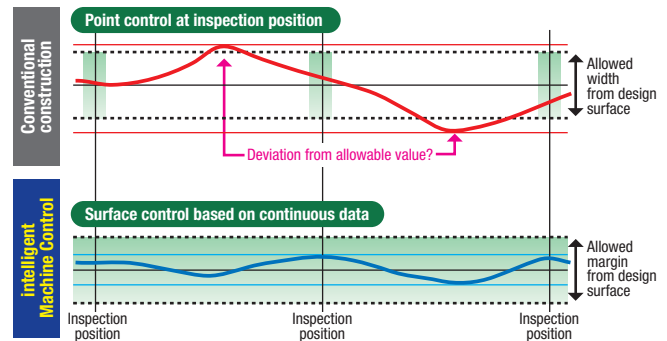

As-Built Surface Track Mapping

Operator can display and check the as-built status and find where to cut and fill.



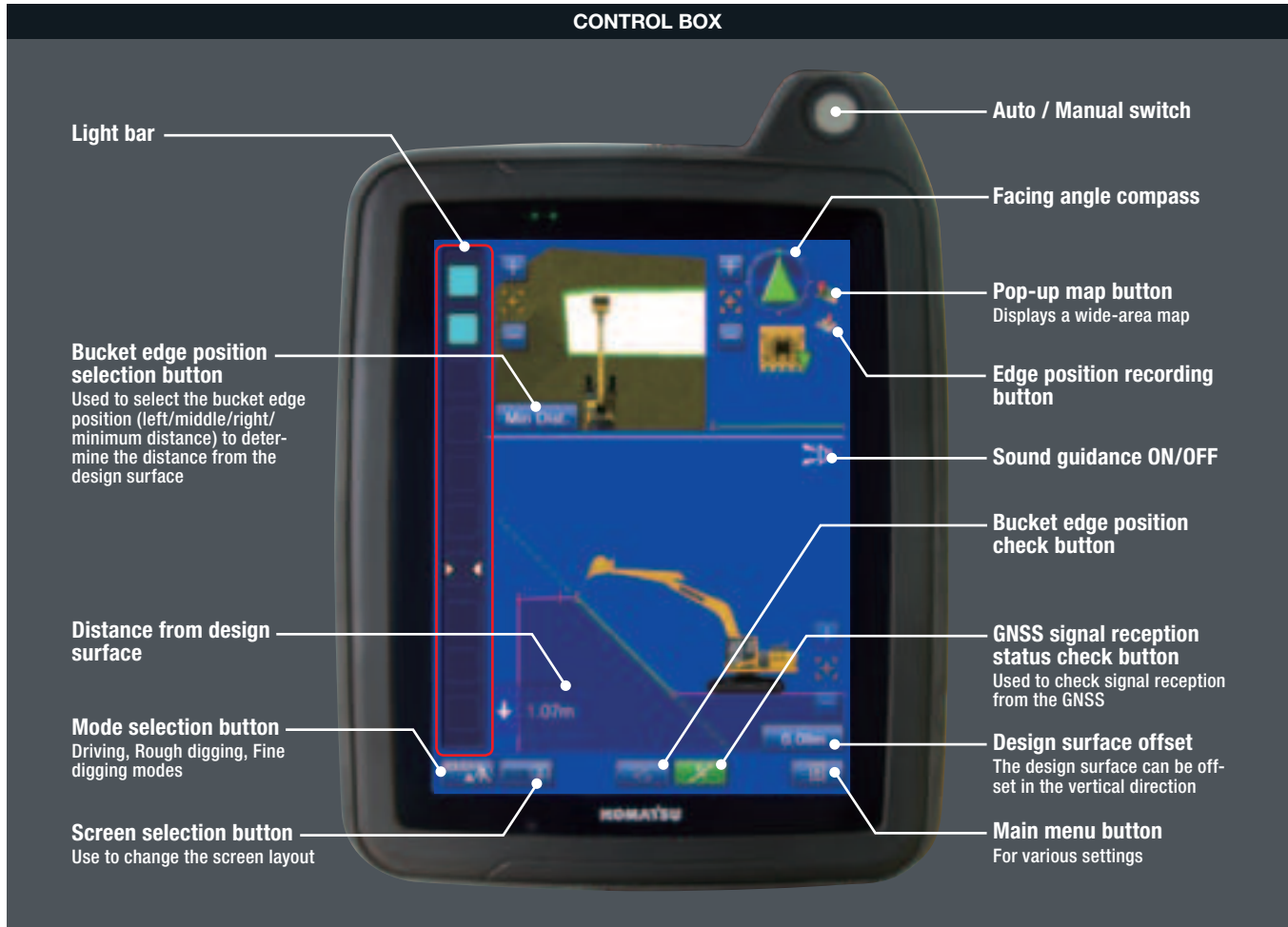

Control Box

The monitor of the Komatsu intelligent Machine Control (control box) uses a large 12.1" (30.7 cm) screen for visibility and ease of use. The simple screen layout displays the necessary information in an easily understood fashion. Touch screen icon interface instead of multi-step menu simplifies operation.

Realistic 3D display

The machine and design surfaces are shown in realistic 3D. The angle and magnification of the views can be changed, which allows the operator to select the optimum view depending on the work conditions.



Machine Navigation

Facing angle compass

The orientation and color of the facing angle compass's arrow shows the operator the facing angle of the bucket edge relative to the target surface. This allows the bucket edge to be accurately positioned square with the target surface, which is useful when finishing slopes.



Bucket Edge Guidance with Eyesight and Sound

Light bar

Colors show the bucket edge position relative to the target surface. Since the light bar is located on the left side of the screen, the bucket edge position can be viewed simply while operating, which increases the work efficiency.



Sound guidance

The operator can recognize the target surfaces not only by eyesight, but also by sound. Unique tones can be programmed for various bucket edge distances from the target surface.



Factory installed Komatsu intelligent Machine Control components

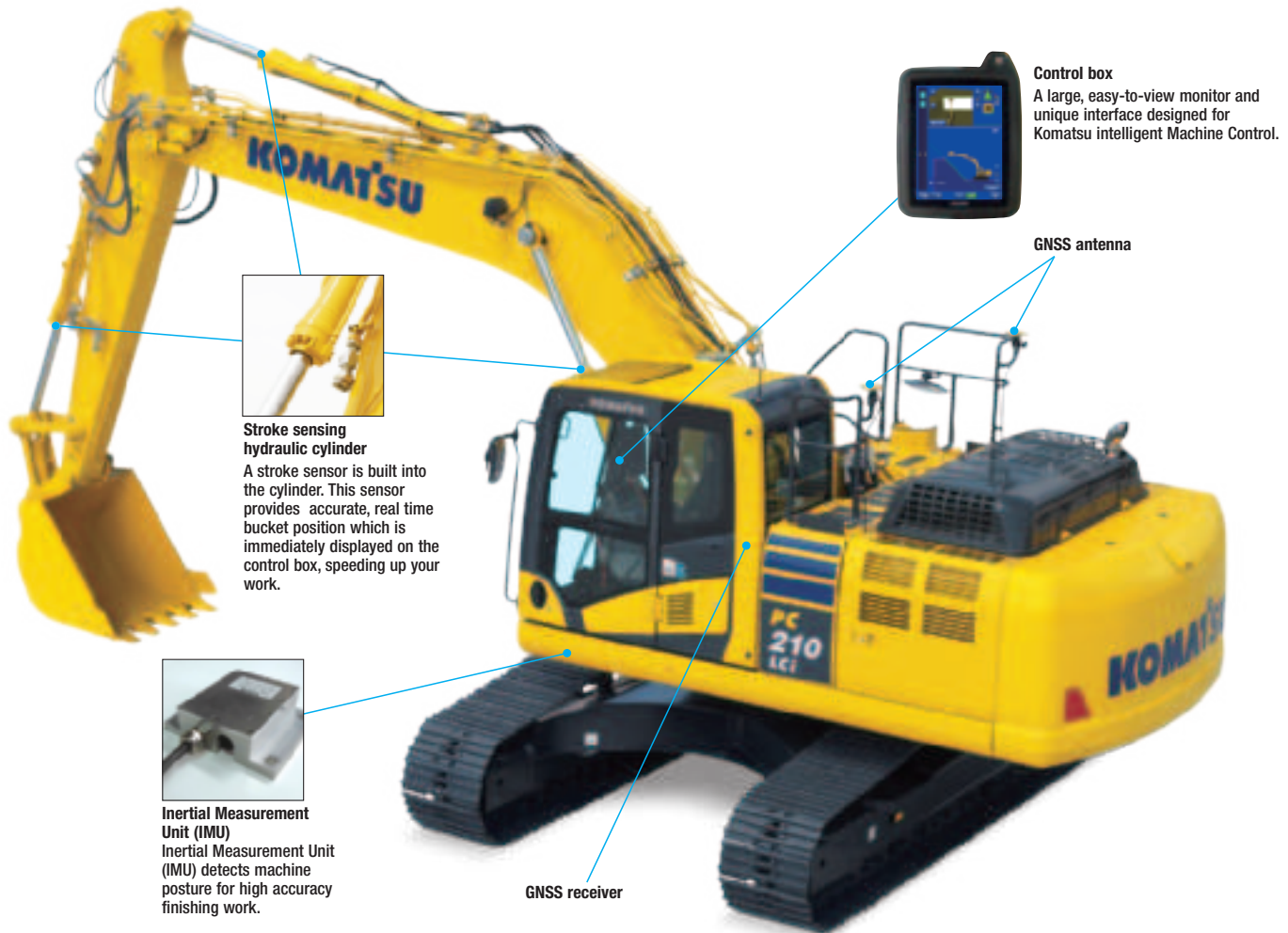

TOPCON Sitelink 3D Enterprise

The Sitelink 3D Enterprise connects the office and machine via a network, visualize the worksite clearly.



Transmission of design data from office to machine



Sending messages from office to machine or vice versa



Progress information and as-built data can be sent to the office from the machine in real time.



Remote assistance function enables troubleshooting from afar via the internet.

Please contact your local Topcon dealer for details.

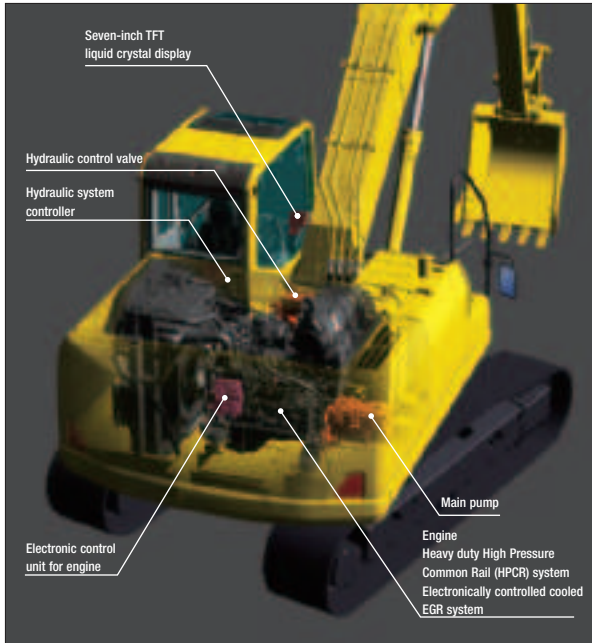

PC200LC-10 representation shown.

Advanced Electronic Control System

The engine control system has been upgraded to effectively manage the air flow rate, EGR gas flow rate, fuel injection parameters, and aftertreatment functions. The new control system also provides enhanced diagnostic capabilities.



Environment-Friendly Engine

The Komatsu SAA6D107E-2 engine is EPA Tier 4 Interim and EU Stage 3B emissions certified and provides exceptional performance while reducing fuel consumption. Based on Komatsu proprietary technologies developed over many years, this new diesel engine reduces exhaust gas particulate matter (PM) by more than 90% and nitrogen oxides (NOx) by more than 45% when compared to Tier 3 levels.

Through the in-house development and production of engines, electronics, and hydraulic components, Komatsu has achieved great advancements in technology, providing high levels of performance and efficiency in virtually all applications.

Komatsu Diesel Particulate Filter (KDPF)

Komatsu has developed a high efficiency diesel particulate filter that captures more than 90% of particulate matter. Both passive and active regeneration are automatically initiated by the engine controller depending on the soot level of the KDPF. A special oxidation catalyst with a fuel injection system is used to oxidize and remove particulate matter while the machine is running so the regeneration process will not interfere with daily operation.

The operator can also initiate regeneration manually or disable regeneration depending on the work environment.

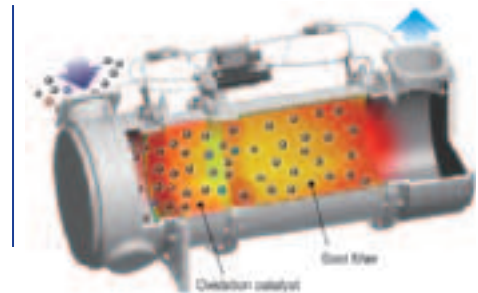

Closed Crankcase Ventilation (CCV)

Crankcase emissions (blow-by gas) are passed through a CCV filter. The CCV filter traps oil mist which is returned back to the crankcase while the gas, which is almost oil mist free, is fed back to the air intake.



Komatsu Variable Geometry Turbocharger (KVG T)

Using Komatsu proprietary technology, a newly designed variable geometry turbocharger with a hydraulic actuator is used to manage and deliver optimum air flow to the combustion chamber under all speed and load conditions. The robust hydraulic actuator provides power and precision, resulting in cleaner exhaust gas and improved fuel economy while maintaining performance.

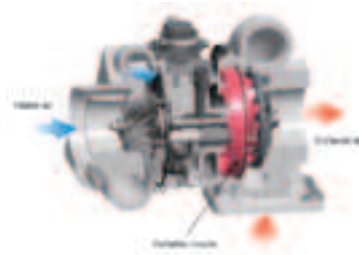

Heavy Duty High Pressure Common Rail (HPCR) Fuel Injection System

The heavy duty HPCR system is electronically controlled to deliver a precise quantity of pressurized fuel into the combustion chamber using multiple injection events to achieve complete fuel burn and reduce exhaust gas emissions. Fuel injector reliability has been improved by using ultra-hard wear resistant materials.



Redesigned Combustion Chamber

The combustion chamber located at the top of the engine piston has a new shape designed to improve combustion and further reduce NOx, PM, fuel consumption, and noise levels.

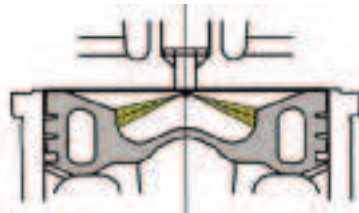

Large Digging Force

The PC210LCi-10 is equipped with the Power Max system. This function temporarily increases digging force for 8.5 seconds of operation.

Maximum arm crowd force (ISO):

101 kN (10.3 t) ➔ **108 kN (11.0 t)** **7 % UP**
(with Power Max.)

Maximum bucket digging force (ISO):

138 kN (14.1 t) ➔ **149 kN (15.2 t)** **8 % UP**
(with Power Max.)

* Measured with Power Max function, 3045 mm arm and ISO rating

Low Operational Noise

The PC210LCi-10 provides low noise operation using a low noise engine and methods that reduce noise at the source such as sound absorbing materials.

Cooled Exhaust Gas Recirculation (EGR)

Cooled EGR, a technology that has been well proven in Komatsu Tier 3 engines, reduces NOx emissions to meet Tier 4 levels. The hydraulically actuated EGR system has increased capacity and uses larger and more robust components to ensure reliability for demanding work conditions.

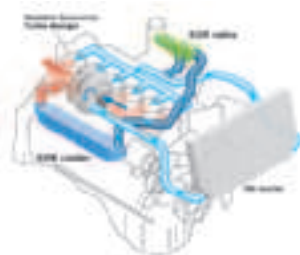

Efficient Hydraulic System

The PC210LCi-10 uses a Closed-center Load Sensing System (CLSS) that improves fuel efficiency and provides quick response to the operator's demands.

The PC210LCi-10 also introduces new technology to enhance the engine and hydraulic pump control. This total control system matches the engine and hydraulics at the most efficient point under any load condition. There have also been improvements in the main valve and hydraulic circuit to reduce hydraulic loss, resulting in higher efficiency and lower fuel consumption.

Reduced Up To 10% Fuel consumption

vs PC200LC-8
Based on typical work pattern collected via KOMTRAX

Large Displacement High Efficiency Pump

Pump displacement has been increased, providing increased flow output as well as operation at the most efficient engine speed.



Idling Caution

To reduce unnecessary fuel consumption, an idling caution is displayed on the monitor if the engine idles for 5 minutes or more.



Working Mode Selection

The PC210LCi-10 excavator is equipped with six working modes (P, E, L, B, ATT/P and ATT/E). Each mode is designed to match engine speed, pump flow, and system pressure to the application. The PC210LCi-10 features a new mode (ATT/E) which allows operators to run attachments while in Economy mode.

Working Mode	Application	Advantage
P	Power mode	<ul style="list-style-type: none"> •Maximum production/power •Fast cycle times
E	Economy mode	<ul style="list-style-type: none"> •Good cycle times •Better fuel economy
L	Lifting mode	<ul style="list-style-type: none"> •Increases hydraulic pressure
B	Breaker mode	<ul style="list-style-type: none"> •Optimum engine rpm, hydraulic flow
ATT/P	Attachment Power mode	<ul style="list-style-type: none"> •Optimum engine rpm, hydraulic flow, 2-way •Power mode
ATT/E	Attachment Economy mode	<ul style="list-style-type: none"> •Optimum engine rpm, hydraulic flow, 2-way •Economy mode

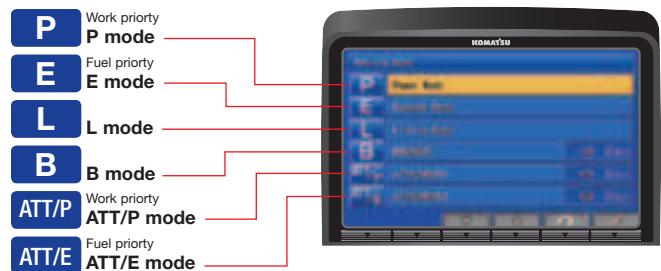

Lifting Mode

When the Lifting mode is selected, the lift capacity is increased 7% by raising the hydraulic pressure.

Ecology-Gauge Assists with Energy Saving Operations

The Ecology-gauge and new fuel consumption gauge are viewed on the right side of the color monitor and assist the operator in maintaining low fuel consumption and environment friendly operation.

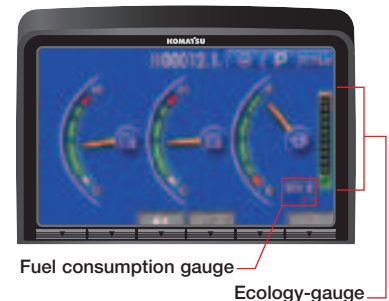

RELIABILITY FEATURES

High Rigidity Work Equipment

Booms and arms are constructed with thick plates of high tensile strength steel. In addition, these structures are designed with large cross-sectional areas and large one piece castings in the boom foot, the boom tip, and the arm tip. The result is work equipment that exhibits long term durability and high resistance to bending and torsional stress.



Komatsu Designed Components

All of the major machine components such as the engine, hydraulic pumps, hydraulic motors, and control valves are exclusively designed and manufactured by Komatsu.

High Efficiency Fuel Filter

A new high efficiency dual element fuel filter improves fuel system reliability.



Equipped with a Fuel Pre-filter (With Water Separator)

A fuel pre-filter removes water and contaminants in the fuel to increase reliability. For convenience, the fuel pre-filter has a built in priming pump.



O-Ring Face Seals

Flat face-to-face O-ring seals are used to securely seal hydraulic hose connections.



Durable Frame Structure

The revolving frame, center frame, and undercarriage are designed using the most advanced three dimensional CAD and FEM analysis technology.

DT-type Connectors

Sealed DT-type connectors provide high reliability, water resistance, and dust resistance.

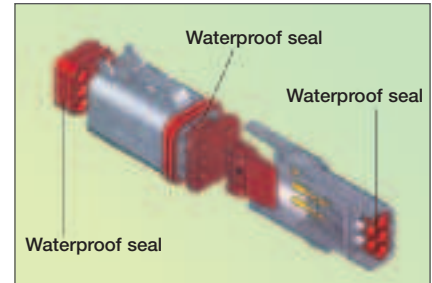

Grease Sealed Track

The PC210LCi-10 uses grease sealed tracks for extended undercarriage life.

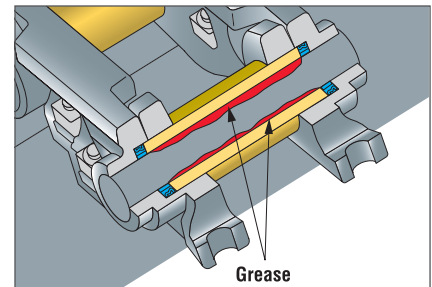

Metal Guard Rings

The PC210LCi-10 uses metal guard rings to protect all of the hydraulic cylinders and improve long term reliability.

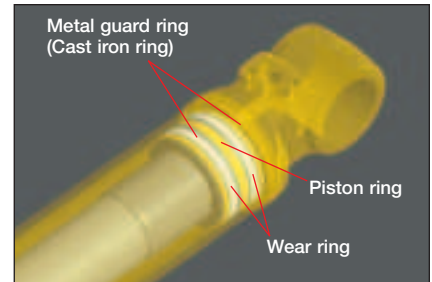

Durable Arm Tip Bushing

The end face of the arm tip bushing provides high resistance to seizure and wear.

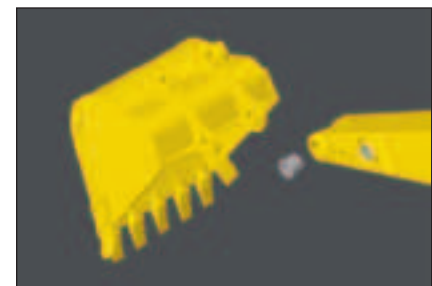

Highly Reliable Electronic Devices

Exclusively designed electronic devices have passed severe testing.

- Controllers
- Sensors
- Connectors
- Heat Resistant Wiring



Photos may include optional equipment.

Newly Designed Wide Spacious Cab

The newly designed wide spacious cab features a high back, fully adjustable seat with a reclining backrest. The console and seat have an integrated design so that they move together and provide additional comfort for the operator.

The new higher capacity operator seat has been enhanced to provide more comfort.

- Heated
- Air Suspension
- Integrated Seat
- Console Mounted Arm Rests



Low Cab Noise

The new cab design is highly rigid and has excellent sound absorption ability. By improving noise source reduction and by using a low noise engine, hydraulic equipment, and air conditioner, this machine is able to generate low noise levels similar to that of a modern automobile.

Automatic Air Conditioner

The automatic air conditioner allows the operator to easily and precisely set the cab atmosphere using the large LCD color monitor panel. The bi-level control function improves air flow and keeps the inside of the cab comfortable throughout the year.

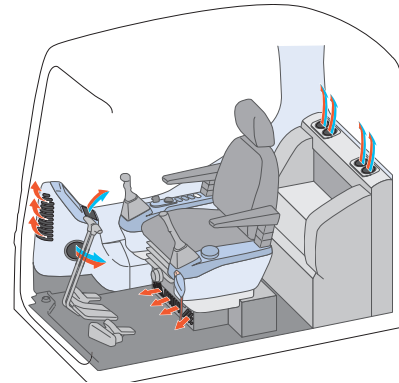

Pressurized Cab

The air conditioner, air filter, and a higher internal cab air pressure minimize the amount of external dust that enters the cab.

Low Vibration with Viscous Cab Mounts

The PC210LCi-10 uses viscous mounts for the cab that incorporate a longer stroke and the addition of a spring. The cab damper mounting combined with a high rigidity deck reduces vibration at the operator's seat.

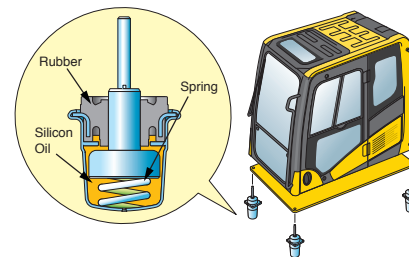

Auxiliary Input (MP3 Jack)

By connecting an auxiliary device such as an MP3 player to the auxiliary input, the operator can hear the sound through the speakers installed in the cab.





Large High Resolution LCD Monitor Panel

A new large, user-friendly, high resolution LCD color monitor enables accurate and smooth work. Screen visibility and resolution are further improved compared to the previous LCD monitor panel. The switches and function keys are easy to operate and provide simple navigation through the monitor screens.

Data is displayed in 25 languages to support operators around the world.

Indicators

- | | |
|----------------------------------|-----------------------------------|
| 1 Auto-decelerator | 5 Hydraulic oil temperature gauge |
| 2 Working mode | 6 Fuel gauge |
| 3 Travel speed | 7 Eco-gauge |
| 4 Engine water temperature gauge | 8 Fuel consumption gauge |
| | 9 Function switches menu |

Basic operation switches

- | | |
|-------------------------|---------------------|
| 1 Auto-decelerator | 4 Buzzer cancel |
| 2 Working mode selector | 5 Wiper |
| 3 Traveling selector | 6 Windshield washer |

Operational "Ecology" Guidance

The monitor panel provides operational advice to the operator to help improve machine efficiency and lower fuel consumption. The operator can access the ecology guidance menu to check the Operation Records, Ecology Guidance Records, and Average Fuel Consumption Logs.



Ecology Guidance

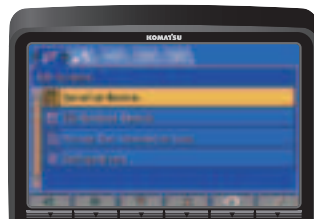

Ecology Guidance menu

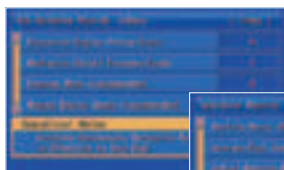

Ecology Guidance Records



Operation Records



Average Fuel Consumption Logs

Improved Attachment Control

The PC210LCi-10 is capable of storing up to ten different attachments in the new monitor panel. The name of each attachment can be changed for better tool management. Hydraulic flow rates can be easily adjusted for one-way and two-way flow attachments.

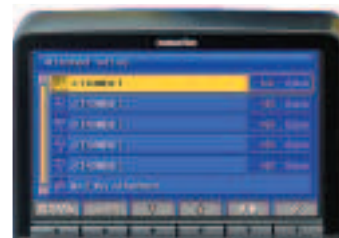

Attachment Setting Screen



Attachment Flow Screen

Easy Access Coolers

The radiator and oil cooler are side-by-side modules which simplifies cleaning, removing, and installing. The swing out cooler design provides easier access to the cooling cores.



KDPF Regeneration Notification

The LCD color monitor panel provides the operator with the status of the KDPF regeneration, without interfering with daily operation.

When the machine initiates active regeneration an icon will appear to notify the operator.

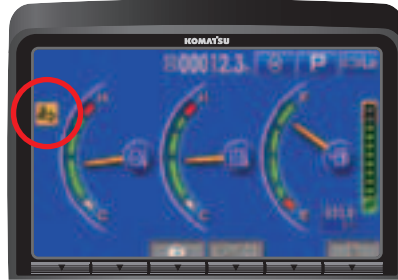

Battery Disconnect Switch

A standard battery disconnect switch allows a technician to disconnect the power supply and lock out before servicing the machine.



Manual Stationary Regeneration

Under most conditions, active regeneration will occur automatically with no effect on machine operation. In case the operator needs to disable active regeneration or initiate a manual stationary regeneration, this can be easily accomplished through the monitor panel.

A soot level indicator is displayed to show how much soot is trapped in the KDPF.

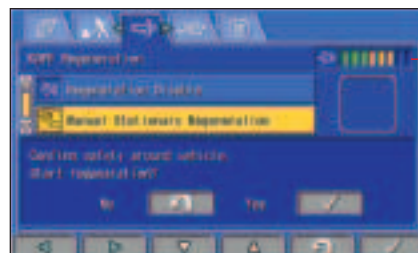

Soot level indicator

Long Life Oils, Filters

High performance filters are used in the hydraulic circuit and engine. By increasing the oil and filter replacement intervals, maintenance costs can be significantly reduced.



Hydraulic oil filter (Ecology-white element)

Engine oil & Engine oil filter	every 500 hours
Hydraulic oil	every 5000 hours
Hydraulic oil filter	every 1000 hours

Extended Work Equipment Greasing Intervals

Special hard material is used for the work equipment bushings to lengthen the greasing intervals. All work equipment bushing lubrication intervals, except the arm tip and bucket linkage, are 500 hours, reducing maintenance costs.



Photos may include optional equipment PC210LC-10 shown

Equipped with Ecology-drain Valve

Minimizes ground contamination due to oil leakage when replacing the engine oil.



Equipment Management Monitoring System (EMMS)

The PC210LCi-10 features an advanced diagnostic system that continuously monitors the machine's vital systems. EMMS tracks maintenance items, provides advanced troubleshooting tools, reduces diagnostic times, and displays error codes. Through continuous monitoring, the EMMS helps identify potential issues and allows the operator to concentrate on the work at hand.

Abnormalities Display with Code

When an abnormality occurs an error code is displayed on the monitor. When an important code is displayed, a caution lamp blinks and a warning buzzer sounds to alert the operator to take action. The monitor also stores a record of abnormalities for more effective troubleshooting.



Advanced Monitoring System

The monitor provides advanced monitoring diagnostics to assist with troubleshooting and reduce downtime.

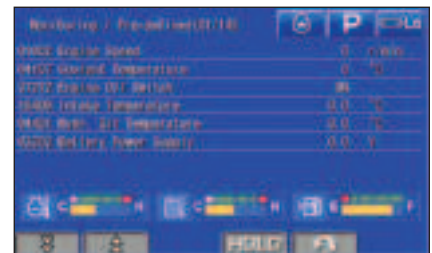

Maintenance Tracking

When the machine approaches or exceeds the oil and filter replacement interval, the monitor panel will display lights to inform the operator.



ROPS Cab Design

The PC210LCi-10 is equipped with an integrated ROPS cab as standard equipment. The cab also meets OPG Top Guard Level 1 requirements.

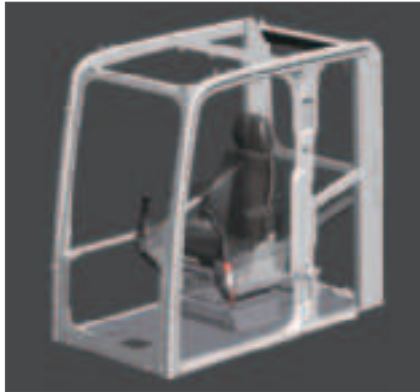

Guardrails

Guardrails have been added on the upper structure of the machine. This provides additional convenience during engine service.



PC210LC-10 shown

Thermal and Fan Guards

Thermal and fan guards are placed around high temperature parts of the engine and fan drive.



Rear-view Monitoring System (standard)

On the large LCD color monitor the operator can view the image from one camera that will display areas directly behind the machine.



Rear view image on monitor

Seat Belt Caution Indicator

A warning indicator on the monitor appears when the seat belt is not engaged.



Lock Lever

When the lock lever is placed in the lock position, all hydraulic controls (travel, swing, boom, arm, and bucket) are inoperable.



Secondary Engine Shutdown Switch

A new secondary switch has been added to shutdown the engine.



Slip Resistant Plates

Durable slip resistant plates maintain excellent foot traction



KOMTRAX EQUIPMENT MONITORING

GET THE WHOLE STORY WITH
KOMTRAX[®]

✓ WHAT

- KOMTRAX is Komatsu's remote equipment monitoring and management system
- KOMTRAX **continuously monitors and records** machine health and operational data
- Information such as fuel consumption, utilization, and a detailed history **aids in making repair or replacement decisions**

✓ WHEN

- Know when your machines are **running or idling** and make decisions that will improve your fleet utilization
- Detailed movement records ensure you know when and where your equipment is moved
- Up to date records allow you to **know when maintenance was done** and help you plan for future maintenance needs

✓ WHERE

- KOMTRAX data **can be accessed virtually anywhere** through your computer, the web or your smart phone
- Automatic alerts keep fleet managers up to date on the latest machine notifications

✓ WHY

- Knowledge is power - **make informed decisions** to manage your fleet better
- Knowing your idle time and fuel consumption will help maximize your machine efficiency
- **Take control of your equipment** - any time, anywhere

✓ WHO

- KOMTRAX is **standard** equipment on all Komatsu construction products



Monthly Operational Analysis

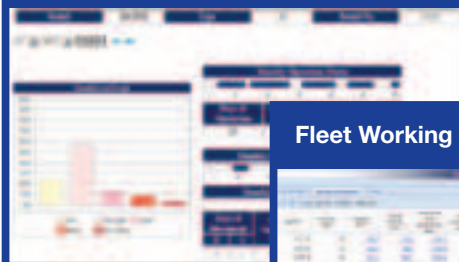

Location/Hours/Working



Fleet Working Status

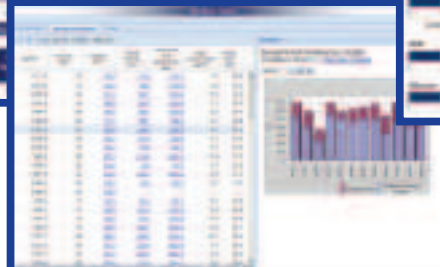

KOMTRAX[®]

For construction and compact equipment.

KOMTRAX Plus[™]

For production and mining class machines.



Komatsu CARE – Complimentary Scheduled Maintenance

- PM services for the earlier of 3 years / 2000 hours
- Performed by factory certified technicians
- Komatsu Genuine parts and fluids
- Significantly lowers your cost of ownership while maintaining high uptime and reliability
- Increases resale value and provides detailed maintenance records
- Extended PM services can be purchased beyond the complimentary period to provide additional peace of mind and maximize uptime



Komatsu CARE – Extended Coverage

- Extended Coverage can provide peace of mind by protecting customers from unplanned expenses that effect cash flow
- Purchasing extended coverage locks-in the cost of covered parts and labor for the coverage period and helps turn these into fixed costs



Komatsu Parts Support

- 24/7/365 to fulfill your parts needs
- 9 parts Distribution Centers strategically located across the U.S. and Canada
- Distributor network of more than 300 locations across U.S. and Canada to serve you
- Online part ordering through Komatsu eParts
- Remanufactured components with same-as-new warranties at a significant cost reduction



Komatsu Oil and Wear Analysis (KOWA)

- KOWA detects fuel dilution, coolant leaks, and measures wear metals
- Proactively maintain your equipment
- Maximize availability and performance
- Can identify potential problems before they lead to major repairs
- Reduce life cycle cost by extending component life

SPECIFICATIONS



ENGINE

Model..... Komatsu SAA6D107E-2*
 Type.....Water-cooled, 4-cycle, direct injection
 Aspiration..... Turbocharged, aftercooled, cooled EGR
 Number of cylinders..... 6
 Bore.....107 mm **4.21"**
 Stroke.....124 mm **4.88"**
 Piston displacement.....6.69 ltr **408 in³**
 Horsepower:
 SAE J1995.....Gross 123 kW **165 HP**
 ISO 9249 / SAE J1349.....Net 118 kW **158 HP**
 Rated rpm..... 2000
 Fan drive method for radiator cooling..... Mechanical
 Governor..... All-speed control, electronic
 *EPA Tier 4 Interim and EU stage 3B emissions certified



HYDRAULICS

Type.....HydrauMind (Hydraulic Mechanical Intelligence New Design) system, closed-center system with load sensing valves and pressure compensated valves
 Number of selectable working modes..... 6
 Main pump:
 Type.....Variable displacement piston type
 Pumps for.....Boom, arm, bucket, swing, and travel circuits
 Maximum flow..... 475 ltr/min **125.5 gal/min**
 Supply for control circuit..... Self-reducing valve
 Hydraulic motors:
 Travel.....2 x axial piston motors with parking brake
 Swing.....1 x axial piston motor with swing holding brake
 Relief valve setting:
 Implement circuits..... 37.3 MPa 380 kg/cm² **5,400 psi**
 Travel circuit..... 37.3 MPa 380 kg/cm² **5,400 psi**
 Swing circuit..... 28.9 MPa 295 kg/cm² **4,190 psi**
 Pilot circuit..... 3.2 MPa 33 kg/cm² **470 psi**

Hydraulic cylinders:

(Number of cylinders – bore x stroke x rod diameter)

Boom .. 2–130 mm x 1334 mm x 90 mm **5.1" x 52.5" x 3.5"**
 Arm1–135 mm x 1490 mm x 95 mm **5.3" x 58.7" x 3.7"**
 Bucket.. 1–115 mm x 1120 mm x 80 mm **4.5" x 44.1" x 3.2"**



DRIVES AND BRAKES

Steering control.....Two levers with pedals
 Drive method..... Hydrostatic
 Maximum drawbar pull.....202 kN 20570 kg **45,349 lb**
 Gradeability.....70%, 35°
 Maximum travel speed: High..... 5.5 km/h **3.4 mph**
 (Auto-Shift) Mid..... 4.1 km/h **2.5 mph**
 (Auto-Shift) Low..... 3.0 km/h **1.9 mph**
 Service brake..... Hydraulic lock
 Parking brake..... Mechanical disc brake



SWING SYSTEM

Drive method..... Hydrostatic
 Swing reduction..... Planetary gear
 Swing circle lubrication..... Grease-bathed
 Service brake..... Hydraulic lock
 Holding brake/Swing lock..... Mechanical disc brake
 Swing speed..... 12.4 rpm
 Swing torque..... 6900 kg•m **49,907 ft lbs**



UNDERCARRIAGE

Center frame..... X-frame
 Track frame..... Box-section
 Seal of track..... Sealed track
 Track adjuster..... Hydraulic
 Number of shoes (each side)..... 49
 Number of carrier rollers (each side)..... 2
 Number of track rollers (each side)..... 9



COOLANT & LUBRICANT CAPACITY (REFILLING)

Fuel tank..... 400 ltr **105.7 U.S. gal**
 Coolant..... 30.7 ltr **8.1 U.S. gal**
 Engine..... 23.1 ltr **6.1 U.S. gal**
 Final drive, each side..... 5.0 ltr **1.3 U.S. gal**
 Swing drive..... 6.5 ltr **1.7 U.S. gal**
 Hydraulic tank..... 132 ltr **34.9 U.S. gal**
 Hydraulic system..... 234 ltr **61.8 U.S. gal**



OPERATING WEIGHT (APPROXIMATE)

Operating weight includes 5700 mm **18'8"** one-piece boom, 2925 mm **9'7"** arm, SAE heaped 1.02 m³ **1.34 yd³** bucket, rated capacity of lubricants, coolant, full fuel tank, operator, and standard equipment.

Triple-Grouser Shoes	Operating Weight	Ground Pressure
700 mm	23323 kg	0.43 kg/cm ²
28"	51,419 lb	6.2 psi
800 mm	23603 kg	0.38 kg/cm ²
31.5"	52,036 lb	5.5 psi

Component Weights

Arm including bucket cylinder and linkage
 2900 mm **9'7"** HD arm assembly..... 1136 kg **2,505 lb**
One piece boom including arm cylinder
 5700 mm **18'8"** HD boom assembly..... 1885 kg **4,156 lb**
 Boom cylinders x 2..... 205 kg **452 lb**
 Counterweight..... 4720 kg **10,406 lb**
 1.02 m³ **1.34 yd³** bucket - 42" width..... 857 kg **1,890 lb**



DIMENSIONS

	Arm Length	2925 mm	9'7"
A	Overall length	9625 mm	31'7"
B	Length on ground (transport)	5000 mm	16'5"
C	Overall height (to top of boom)*	2996 mm	9'9"
D	Overall width	3180 mm	10'5"
E	Overall height (to top of cab)*	3045 mm	10'0"
F	Overall height (to top of handrail)*	3135 mm	10'3"
G	Ground clearance, counterweight	1085 mm	3'7"
H	Ground clearance, minimum	440 mm	1'5"
I	Tail swing radius	2940 mm	9'8"
J	Track length on ground	3655 mm	12'0"
K	Track length	4450 mm	14'7"
L	Track gauge	2380 mm	7'10"
M	Width of crawler	3180 mm	10'5"
N	Shoe width	800 mm	31.5"
O	Grouser height	26 mm	1.0"
P	Machine cab height	2605 mm	8'7"
Q	Machine cab width **	2850 mm	9'4"
R	Distance, swing center to rear end	2910 mm	9'7"

* : Including grouser height
 ** : Including handrail

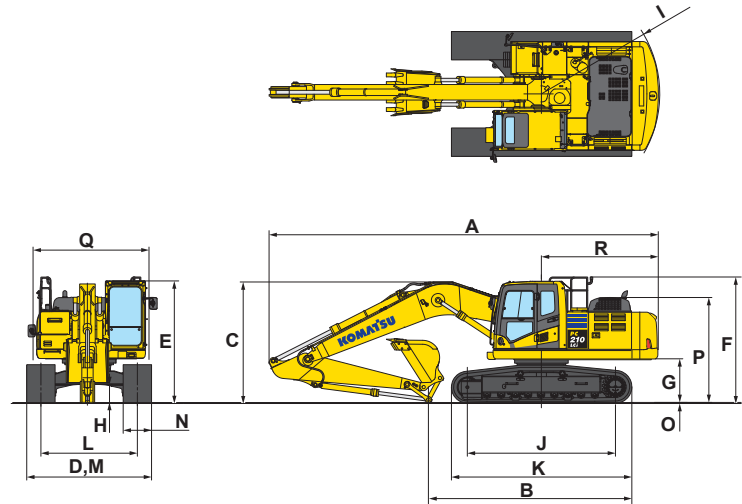

BACKHOE BUCKET, ARM AND BOOM COMBINATION

Bucket Type	Bucket				5.7 m (18'8") Boom		
	Capacity		Width		Weight	2.9 m (9'7")	
Komatsu TL	0.50 m ³	0.66 yd³	610 mm	24"	605 kg	1,334 lb	V
	0.67 m ³	0.88 yd³	762 mm	30"	689 kg	1,518 lb	V
	0.85 m ³	1.11 yd³	914 mm	36"	780 kg	1,719 lb	V
	1.02 m ³	1.34 yd³	1067 mm	42"	857 kg	1,890 lb	W
	1.20 m ³	1.57 yd³	1219 mm	48"	949 kg	2,092 lb	X
Komatsu HP	0.50 m ³	0.66 yd³	610 mm	24"	652 kg	1,437 lb	V
	0.67 m ³	0.88 yd³	762 mm	30"	763 kg	1,681 lb	V
	0.85 m ³	1.11 yd³	914 mm	36"	868 kg	1,913 lb	V
	1.02 m ³	1.34 yd³	1067 mm	42"	950 kg	2,095 lb	W
	1.20 m ³	1.57 yd³	1219 mm	48"	1066 kg	2,349 lb	Y
Komatsu HPS	0.50 m ³	0.66 yd³	610 mm	24"	724 kg	1,597 lb	V
	0.67 m ³	0.88 yd³	762 mm	30"	840 kg	1,851 lb	V
	0.85 m ³	1.11 yd³	914 mm	36"	962 kg	2,120 lb	V
	1.02 m ³	1.34 yd³	1067 mm	42"	1061 kg	2,339 lb	X
	1.20 m ³	1.57 yd³	1219 mm	48"	1193 kg	2,630 lb	Y
Komatsu HPX	0.50 m ³	0.66 yd³	610 mm	24"	824 kg	1,817 lb	V
	0.67 m ³	0.88 yd³	762 mm	30"	939 kg	2,071 lb	V
	0.85 m ³	1.11 yd³	914 mm	36"	1061 kg	2,340 lb	W
	1.02 m ³	1.34 yd³	1067 mm	42"	1161 kg	2,559 lb	X
	1.20 m ³	1.57 yd³	1219 mm	48"	1293 kg	2,850 lb	Y

V - Used with material weights up to 3,500 lb/yd³
 X - Used with material weights up to 2,500 lb/yd³
 Z - Not useable

W - Used with material weights up to 3,000 lb/yd³
 Y - Used with material weights up to 2,000 lb/yd³



WORKING RANGE

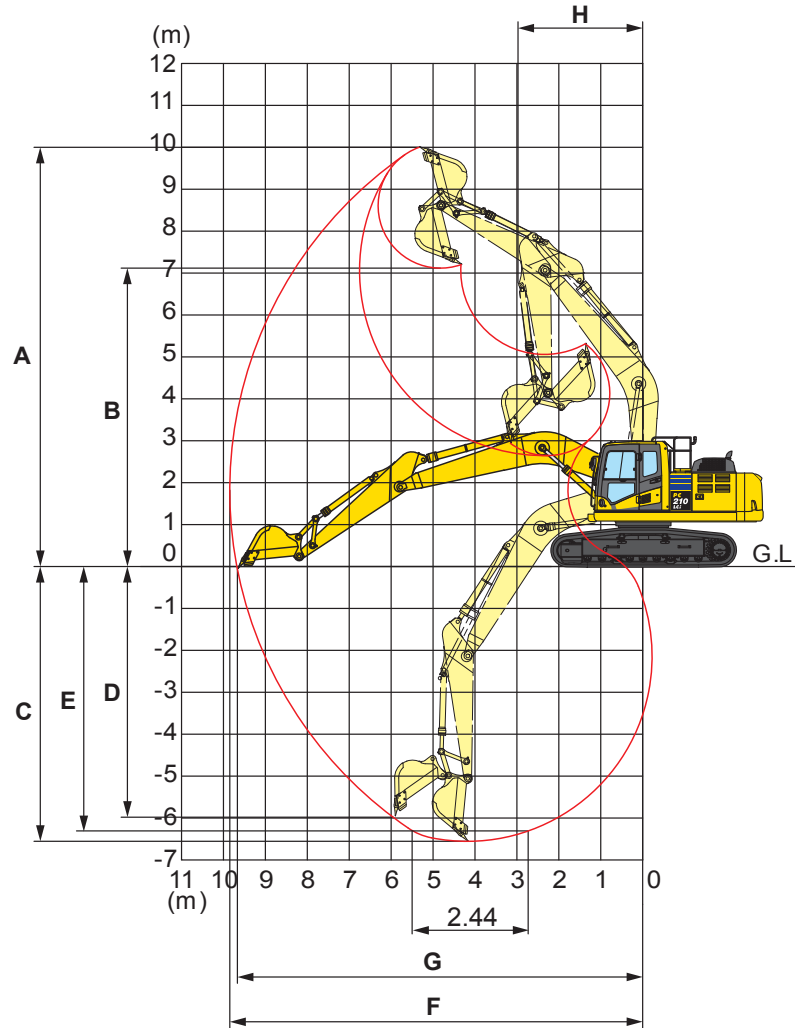

	Arm Length	2925 mm	9'7"
A	Max. digging height	9970 mm	32'9"
B	Max. dumping height	7110 mm	23'4"
C	Max. digging depth	6620 mm	21'9"
D	Max. vertical wall digging depth	5980 mm	19'7"
E	Max. digging depth for 8' level bottom	6370 mm	20'11"
F	Max. digging reach	9875 mm	32'5"
G	Max. digging reach at ground level	9700 mm	31'10"
H	Min. swing radius	3040 mm	10'0"
SAE rating	Bucket digging force at power max.	132 kN	
		13500 kg / 29,762 lb	
	Arm crowd force at power max.	103 kN	
		10500 kg / 23,149 lb	
ISO rating	Bucket digging force at power max.	149 kN	
		15200 kg / 33,510 lb	
	Arm crowd force at power max.	108 kN	
		11000 kg / 24,250 lb	

LIFT CAPACITIES



LIFTING CAPACITY WITH LIFTING MODE

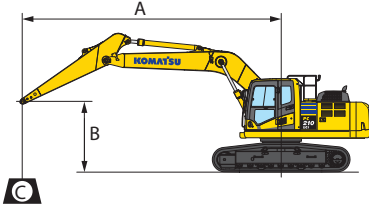

- A: Reach from swing center
- B: Bucket hook height
- C: Lifting capacity
- Cf: Rating over front
- Cs: Rating over side
- ⊗ : Rating at maximum reach

- Conditions :
- 5700 mm 18' 8" one-piece boom
 - Counterweight: 4720 kg 10,406 lb
 - Bucket: None
 - Lifting mode: On

Arm: 2925 mm 9'7" HD Shoes: 700 mm 28" Unit: kg lb

B \ A	3.0 m 10'		4.6 m 15'		6.1 m 20'		7.6 m 25'		9.1 m 30'		⊗ MAX	
	Cf	Cs	Cf	Cs	Cf	Cs	Cf	Cs	Cf	Cs	Cf	Cs
7.6 m 25'											* 4110	* 4110
6.1 m 20'					* 5450	* 5450					* 9080	* 9080
4.6 m 15'			* 6710	* 6710	* 12020	* 12020	* 5250	4250			* 3860	* 3860
3.0 m 10'	* 12840	* 12840	* 14800	* 14800	* 13200	* 13050	* 11580	9370			* 8510	* 8510
1.5 m 5'			* 10440	8080	* 7790	5470	6010	4050			* 3950	3690
0 m 0'	* 7480	* 7480	* 23030	17820	* 17180	12070	13250	8940			* 8700	8130
-1.5 m -5'	* 12020	* 12020	* 11470	7810	8120	5310	5920	3970			* 4230	3570
-3.0 m -10'	* 16500	* 16500	* 25290	17230	17910	11710	13050	8760			* 9330	7880
-4.6 m -15'	* 26510	* 26510	* 25620	17050	17740	11560	* 12940	8720			* 4750	3640
	* 15440	14780	* 10910	7790	8090	5280					* 5680	3940
	* 34050	32600	* 24060	17180	17830	11640					* 12530	8700
	* 12360	* 12360	* 8820	8010							* 7030	4660
	* 27260	* 27260	* 19450	17660							* 15500	10280
											* 7380	6580
											* 16270	14520

*Load is limited by hydraulic capacity rather than tipping. Ratings are based on ISO standard No. 10567. Rated loads do not exceed 87% of hydraulic lift capacity or 75% of tipping load.

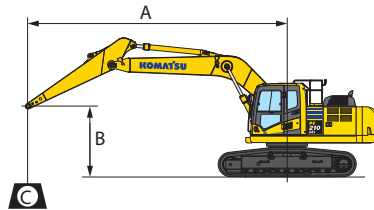

- A: Reach from swing center
- B: Bucket hook height
- C: Lifting capacity
- Cf: Rating over front
- Cs: Rating over side
- ⊗ : Rating at maximum reach

- Conditions :
- 5700 mm 18' 8" one-piece boom
 - Counterweight: 4720 kg 10,406 lb
 - Bucket: None
 - Lifting mode: On

Arm: 2925 mm 9'7" HD Shoes: 800 mm 31.5" Unit: kg lb

B \ A	3.0 m 10'		4.6 m 15'		6.1 m 20'		7.6 m 25'		9.1 m 30'		⊗ MAX	
	Cf	Cs	Cf	Cs	Cf	Cs	Cf	Cs	Cf	Cs	Cf	Cs
7.6 m 25'											* 4110	* 4110
6.1 m 20'					* 5450	* 5450					* 9080	* 9080
4.6 m 15'			* 6710	* 6710	* 12020	* 12020	* 5250	4290			* 3860	* 3860
3.0 m 10'	* 12840	* 12840	* 14800	* 14800	* 13200	13170	* 11580	9460			* 8510	* 8510
1.5 m 5'			* 10440	8160	* 7790	5530	6070	4100			* 3820	* 3820
0 m 0'	* 7480	* 7480	* 23030	18000	* 17180	12190	13390	9030			* 8430	* 8430
-1.5 m -5'	* 12020	* 12020	* 11470	7890	8210	5370	5980	4020			* 3950	3720
-3.0 m -10'	* 16500	* 16500	* 25290	17410	18110	11840	13200	8860			* 4230	3610
-4.6 m -15'	* 26510	* 26510	* 25620	17230	17940	11680	* 12940	8820			* 9330	7970
	* 15440	14930	* 10910	7870	* 8120	5330					* 4750	3680
	* 34050	32930	* 24060	17360	* 17910	11760					* 5680	3990
	* 12360	* 12360	* 8820	8090							* 12530	8800
	* 27260	* 27260	* 19450	17830							* 7100	4710
											* 15670	10380
											* 7380	6650
											* 16270	14670

*Load is limited by hydraulic capacity rather than tipping. Ratings are based on ISO standard No. 10567. Rated loads do not exceed 87% of hydraulic lift capacity or 75% of tipping load.



STANDARD EQUIPMENT

- Alternator, 60 Ampere, 24V
- AM/FM radio
- Automatic engine warm-up system
- Automatic air conditioner/heater
- Auxiliary input (3.5mm jack)
- Batteries, large capacity
- Battery disconnect switch
- Boom and arm holding valves
- Converter, (2) x 12V
- Counterweight, 4720 kg **10,406 lb**
- Dry type air cleaner, double element
- Electric horn
- EMMS monitoring system
- Engine, Komatsu SAA6D107E-2
- Engine overheat prevention system
- Extended work equipment grease interval
- Fan guard structure
- Fuel system pre-cleaner 10 micron
- High back air suspension seat, with heat
- Hydraulic track adjusters
- Intelligent Machine Control
- KOMTRAX® Level 4.0
- Large LCD color monitor, high resolution
- Lock lever
- Mirrors, (LH and RH)
- Operator Protective Top Guard (OPG), Level 1
- Pattern change valve (ISO to BH control)
- Power maximizing system
- PPC hydraulic control system
- Pump/engine room partition cover
- Radiator and oil cooler dustproof net
- Rear reflectors
- Rearview monitoring system (1 camera)
- Revolving frame deck guard
- Revolving frame undercovers
- ROPS cab
- Seat belt, retractable, 76mm **3"**
- Seat belt indicator
- Secondary engine shutoff switch
- Service valve
- Shoes, triple grouser, 800mm **31.5"**
- Skylight
- Slip resistant foot plates
- Starter motor, 5.5kW/24V x 1
- Suction fan
- Thermal and fan guards
- Track frame undercover
- Travel alarm
- Working lights, 2 (boom and RH front)
- Working mode selection system



OPTIONAL EQUIPMENT

- Additional front working lights
- Arms
 - 2925 mm **9'7"** HD arm assembly
- Booms
 - 5700 mm **18'8"** HD boom assembly
- Cab guards
 - Full front guard, OPG Level 1
 - Lower front window guard
- Rain visor
- Sun visor

PC210LCI-10



AESS872-02

©2015 Komatsu America Corp.

Printed in USA

AD01(2.5M)OTP

05/15 (EV-1)

KOMATSU®

Note: All comparisons and claims of improved performance made herein are made with respect to the prior Komatsu model unless otherwise specifically stated.

www.komatsuamerica.com

Komatsu America Corp. is an authorized licensee of Komatsu Ltd. Materials and specifications are subject to change without notice.

KOMATSU®, Komatsu Care® and KOMTRAX® are registered trademarks of Komatsu Ltd.

All other trademarks and service marks used herein are the property of Komatsu Ltd., Komatsu America Corp. or their respective owners or licensees.