

KOMATSU

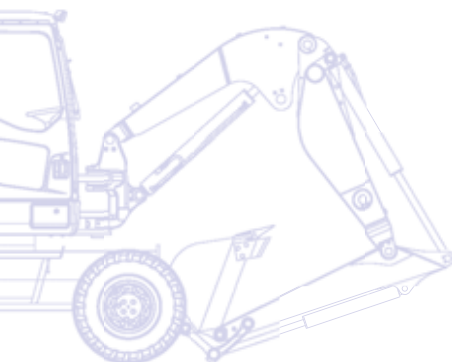

Midi-Excavator **PW98MR-6**



ENGINE POWER
53,1 kW / 71,2 HP @ 2.000 rpm

OPERATING WEIGHT
9.050 - 9.840 kg

BUCKET CAPACITY
0,077 - 0,282 m³

Courtesy of Machine.Market

Walk-Around

The new PW98MR-6 compact midi-excavator is the result of expertise and technology that Komatsu has developed from over 80 years' experience. Developed with constant attention to the needs of customers all over the world, the PW98MR-6 is a user-friendly machine that delivers top-class performance. It has a tight tail swing and protrudes over the wheels by just 153 mm. So the operator can concentrate on the work in front, without having to worry about rear-swing impacts.

Cutting-edge hydraulic circuit

- CLSS (Closed-centre Load Sensing System)
- Perfect control even during combined operations
- Fast and precise movements



Outstanding performances

- Excellent stability
- Optimal combination of power and digging speed
- Engine controller for fuel injection and emission management

PW98MR-6

ENGINE POWER
53,1 kW / 71,2 HP @ 2.000 rpm

OPERATING WEIGHT
9.050 - 9.840 kg

BUCKET CAPACITY
0,077 - 0,282 m³

First-class operator comfort

- Spacious working environment
- Sliding door
- Proportional Pressure Control (PPC) servo-controls
- Air conditioning (option)



Total versatility

- 4-wheel steering enabling 3 steering modes
- Ideal for work in confined areas
- Standard 1 or 2 way auxiliary line for attachments

Easy maintenance

- Optimal maintenance layout
- Quick access to all daily inspection points
- Long maintenance intervals



KOMTRAX

Komatsu Satellite
Monitoring System

First-Class Operator Comfort



An optimal work environment

Despite its compact size, the PW98MR-6 offers unequalled comfort. The spacious cab was developed with exceptional care to details, and the work environment is quiet and comfortable. Special attention is given to the operator: ergonomic and dedicated PPC controls, and, in option, an efficient air conditioning (optional) and ventilation system to guarantee optimal thermal comfort. Large windows, including an openable side window, and a special panel design provide outstanding 360° visibility. Last, but not least, the upper rail sliding door makes getting in and out of the machine very easy and safe in any situation.

Large multi-function monitor

A large and user-friendly monitor makes working in a PW98MR-6 safe, accurate and smooth. Its highly intuitive interface and easy-to-operate switches give the operator access to a huge range of functions and steering modes selection.



Sliding door for easy entry and exit



Wide glass surface for excellent all around visibility



Large multi-function monitor

Outstanding Performances



Absolute control

The PPC servo controls allow extremely precise movements with very little effort. To simplify and speed up working cycles, all movements can be done simultaneously, and each has its own dedicated control. Smooth manoeuvring combined with a perfect view of the working area, guarantees maximum productivity for even the toughest jobs.

A speed sensor - and two power modes

To optimize power usage, the PW98MR-6 is fitted with an engine speed sensor. The main pump's power is automatically adjusted to the engine speed and the computerised system keeps this speed constant during high load conditions. Two distinct hydraulic power modes - 'Power' or 'Economy' - let the operator conveniently choose between maximum power or minimum fuel consumption.



Cutting-Edge Hydraulic Circuit

Komatsu CLSS

The CLSS (Closed-centre Load Sensing System) hydraulic circuit guarantees power, speed and perfect control to all movements, including simultaneous ones. The combination of the variable displacement pump and of CLSS allows operators to perform all

required movements with maximum efficiency, regardless of the load or rpm. The unique CLSS characteristics are perfectly complemented by the hydraulic servo-controls, which are, by far, the easiest to use and that allow extremely precise manoeuvres with minimal effort.





Work in tight spaces

The short-tail PW98MR-6 delivers optimal power and digging speed, even in confined spaces where traditional machines can't work: yards, road works, demolition sites, sewers, etc. Sturdy and very stable, it guarantees maximum safety and offers complete operator confidence in any working conditions.

4-wheel steering

It's possible to select between 3 steering modes: 2-wheel steering (for travelling), 4-wheel steering (for fast, agile operation) and crab (for confined areas). This ensures outstanding versatility and manoeuvrability. It's easy and safe to change the steering mode: just push 2 switches at the same time on the new panel, and a green lamp will inform you of the steering mode selected. When working, the front-axel oscillation can be blocked for improved stability.



Easy Maintenance

Excellent serviceability

Komatsu designed the PW98MR-6 with an easy access to all service points. Routine maintenance and servicing are less likely to be skipped, which can mean a reduction of costly downtime later on. All periodic inspection points are easily accessible via two bonnets that can be opened even in confined areas. Inspection windows for the battery and fuel system enable quick and easy maintenance. O-ring face seal (ORFS) hydraulic connectors and DT electric connectors improve machine reliability and make repairs simpler and faster.



Ground level battery access



All periodic inspection points are easily accessible

Komatsu Satellite Monitoring System



KOMTRAX™ is a revolutionary machine tracking system designed to save you time and money. You can now monitor your equipment anytime and anywhere. Use valuable machine data received via the KOMTRAX™ web site to optimise your maintenance planning and machine performances.

With KOMTRAX™, you can:

- Check when & where your machines are at work
- Be informed of unauthorized machine use or movement
- Set and receive e-mail notification for security alarms

For further details on KOMTRAX™, please ask your Komatsu dealer for the latest KOMTRAX™ brochure.



Machine working time - With the "daily working record" chart, get precise engine running time data: when your machine was started and when it was shut down, as well as total engine running time.



Fleet location - The machine list instantly locates all your machines, even those in other countries.



Alarm notifications - You can receive notification of alarms both via the KOMTRAX™ website and by e-mail.



Added security - The "engine lock" feature allows to program when a machine's engine can be started. And with "geo-fence", KOMTRAX™ sends notification every time your machine moves in or out of a predetermined operating area.



Specifications

ENGINE

| | |
|------------------------------------|--|
| Model | Komatsu S4D95LE-3 |
| Type | direct injection, water-cooled, emissionised, turbocharged |
| No. of cylinders | 4 |
| Displacement..... | 3.260 cm ³ |
| Engine power | |
| at rated engine speed | 2.000 rpm |
| ISO 14396 | 53,1 kW / 71,2 HP |
| SAE J1349 (net engine power) | 51,0 kW / 68,4 HP |
| Max. torque/engine speed | 271 Nm @ 1.600 rpm |

OPERATING WEIGHT

Operating weight, including 1.650 mm arm, 0,28 m³ bucket (ISO 7451), blade, operator, liquids, filled tank and standard equipment (ISO 6016).

| | Width | Operating weight with two-piece boom |
|----------------------------|----------|--------------------------------------|
| Basic version | 2.316 mm | 9.050 kg |
| With rear blade | 2.350 mm | 9.540 kg |
| With rear stabilizers | 2.316 mm | 9.350 kg |
| With blade and stabilizers | 2.350 mm | 9.840 kg |

TRANSMISSION

Hydrostatic transmission with four driving wheels. The hydraulic motor acts by means of a synchromesh gear that makes for two speed ranges.

| | |
|------------------------------|---------------------------|
| Maximum traction force | 5.690 daN (5.800 kg) |
| Working speed | 1st 6 km/h - 2nd 10 km/h |
| Travelling speed..... | 3rd 23 km/h - 4th 30 km/h |

AXLES

Driving and steering axles with epicyclic reduction gears in the hubs. The oscillation of the front axle can be blocked by means of two hydraulic pistons.

Tyres:

| | |
|-----------------------------|---------|
| Twin tyres (standard) | 8.25-20 |
| Single tyres (option) | 18-19.5 |

STEERING

Hydraulically operated steering system that acts on the front and rear wheels by means of double rod hydraulic cylinders in the axles. The operator can select three kinds of steering by means of an electric switch:

- two steering wheels
- four steering wheels
- crab steering

Steering radius:

| | |
|---------------------------|----------|
| Two steering wheels | 6.010 mm |
| Four steering wheels..... | 4.040 mm |

ENVIRONMENT

Vibration levels (EN 12096:1997)*

| | |
|----------------|--|
| Hand/arm | ≤ 2,5 m/s ² (uncertainty K = 1,2 m/s ²) |
| Body | ≤ 0,5 m/s ² (uncertainty K = 0,2 m/s ²) |

* for the purpose of risk assessment under directive 2002/44/EC, please refer to ISO/TR 25398:2006.

HYDRAULIC SYSTEM

| | |
|---|-------------------------------------|
| Type | Komatsu CLSS |
| Power modes | 2 (Power/Economy) |
| Main pumps: | |
| Pump for..... | boom, arm, bucket and travelling |
| Type | variable displacement, axial piston |
| Maximum flow | 165 ltr/min |
| Pump for..... | swing and blade |
| Type | fixed displacement gear pump |
| Maximum flow | 66 ltr/min |
| Auxiliary hydraulic flow | 145 ltr/min |
| Relief valve settings: | |
| Swing and blade..... | 21,1 MPa (215 kg/cm ²) |
| Travel and work equipment | 26,5 MPa (270 kg/cm ²) |
| Bucket breakout force (ISO 6015) | 6.129 daN (6.250 kg) |
| Arm breakout force, 1.650 mm arm (ISO 6015)..... | 4.148 daN (4.230 kg) |

SWING SYSTEM

| | |
|--------------------------------|------------------------------------|
| Driven by | hydraulic motor |
| Swing reduction gear | with double epicyclic reduction |
| Swing circle lubrication | grease-bathed |
| Swing brakes..... | automatic, with oil immersed discs |
| Swing speed..... | 10 rpm |

BRAKES

Service and emergency brakes:

Hydraulically controlled, with pedal, by means of two double circuit pumps, acting on oil immersed multiple discs on the four wheels.

Working brakes:

Hydraulically controlled by means of a pedal, acting on the four wheels

Parking brakes:

Negative type brakes, hydraulically controlled by means of an electric push button positioned inside the cab, acting on the rear axle. The parking brake is automatically operated every time the engine cuts off with a consequent decrease of the oil pressure.

ELECTRIC SYSTEM

| | |
|---------------------|-----------|
| Voltage..... | 24 V |
| Battery | 2 × 65 Ah |
| Alternator..... | 60 A |
| Starter motor | 3 kW |

SERVICE REFILL CAPACITIES

| | |
|-------------------------|---------------|
| Fuel tank | 125 ltr |
| Cooling system..... | 18 ltr |
| Engine oil..... | 10,5 (10) ltr |
| Hydraulic oil tank..... | 110 (64) ltr |

CAB

Sound-proof cab, provided with safety glasses, liftable windscreen, roof window with protection grid, sliding door with lock, windscreen-wiper, electric horn, adjustable seat with double slide, control system and instrumentation, adjustable joysticks. Outside air inlet.

LIFTING CAPACITY

A – Reach from swing centre

B – Height at bucket pin

 – Rating over front









 – Rating over side

DATAS AND SPECIFICATIONS ARE REFERRING TO THE MACHINE ACCORDING TO 89/392/CE AND EN 474-5 DIRECTIVES.

When removing bucket, linkage or cylinder, lifting capacities can be increased by their respective weights.

Lifting capacities with 800 mm bucket (236 kg), twin tyres (8.25-20), blade, levers and cylinder.

With blade up

| B \ A | 3,0 m | | 4,0 m | | 5,0 m | | 6,0 m | |
|-------|---|---|---|---|---|---|---|---|
| |  |  |  |  |  |  |  |  |

| Arm length 1.650 mm | 3,0 m | kg | 2.400* | 2.400* | 1.500 | 1.400 | 1.050 | 950 | 800 | 700 |
|------------------------|--------|----|--------|--------|-------|-------|-------|-----|-----|-----|
| | 1,5 m | kg | 2.340* | 2.340* | 1.400 | 1.300 | 1.000 | 900 | 750 | 650 |
| | 0,0 m | kg | 2.450* | 2.100 | 1.350 | 1.250 | 900 | 800 | 700 | 600 |
| | -1,5 m | kg | 2.500* | 2.100 | 1.350 | 1.250 | 900 | 800 | --- | --- |

without additional counterweight









| Arm length 1.900 mm | 3,0 m | kg | --- | --- | 1.550 | 1.450 | 1.100 | 1.000 | 850 | 750 |
|------------------------|--------|----|--------|--------|-------|-------|-------|-------|-----|-----|
| | 1,5 m | kg | 2.200* | 2.200* | 1.450 | 1.350 | 1.050 | 950 | 800 | 700 |
| | 0,0 m | kg | 2.400* | 2.000 | 1.400 | 1.300 | 950 | 850 | 750 | 650 |
| | -1,5 m | kg | 2.450* | 2.000 | 1.400 | 1.300 | 950 | 850 | 750 | 650 |

with 215 kg additional counterweight

| Arm length 2.250 mm | 3,0 m | kg | --- | --- | 1.600 | 1.500 | 1.150 | 1.050 | 900 | 800 |
|------------------------|--------|----|--------|-------|-------|-------|-------|-------|-----|-----|
| | 1,5 m | kg | --- | --- | 1.500 | 1.400 | 1.100 | 1.000 | 850 | 750 |
| | 0,0 m | kg | 2.300* | 1.900 | 1.450 | 1.350 | 1.000 | 900 | 800 | 700 |
| | -1,5 m | kg | 2.350* | 1.900 | 1.450 | 1.350 | 1.000 | 900 | 800 | 700 |

with 464 kg additional counterweight

With blade at ground level

| B \ A | 3,0 m | | 4,0 m | | 5,0 m | | 6,0 m | |
|-------|---|---|---|---|---|---|---|---|
| |  |  |  |  |  |  |  |  |

| Arm length 1.650 mm | 3,0 m | kg | 2.400* | 2.400* | 2.250* | 1.500 | 2.100* | 1.050 | 1.950* | 800 |
|------------------------|--------|----|--------|--------|--------|-------|--------|-------|--------|-----|
| | 1,5 m | kg | 2.340* | 2.340* | 2.200* | 1.400 | 2.050* | 1.000 | 1.900* | 750 |
| | 0,0 m | kg | 2.450* | 2.450* | 2.300* | 1.350 | 2.150* | 950 | 2.000* | 700 |
| | -1,5 m | kg | 2.500* | 2.500* | 2.350* | 1.350 | 2.200* | 900 | --- | --- |

without additional counterweight

| Arm length 1.900 mm | 3,0 m | kg | --- | --- | 2.200* | 1.550 | 2.050* | 1.100 | 1.900* | 850 |
|------------------------|--------|----|--------|--------|--------|-------|--------|-------|--------|-----|
| | 1,5 m | kg | 2.200* | 2.200* | 2.150* | 1.450 | 2.000* | 1.050 | 1.850* | 800 |
| | 0,0 m | kg | 2.400* | 2.400* | 2.250* | 1.400 | 2.100* | 1.000 | 1.950* | 750 |
| | -1,5 m | kg | 2.450* | 2.450* | 2.300* | 1.400 | 2.150* | 950 | 2.000* | 750 |

with 215 kg additional counterweight

| Arm length 2.250 mm | 3,0 m | kg | --- | --- | 2.150* | 1.600 | 2.000* | 1.150 | 1.850* | 900 |
|------------------------|--------|----|--------|--------|--------|-------|--------|-------|--------|-----|
| | 1,5 m | kg | --- | --- | 2.100* | 1.500 | 1.950* | 1.100 | 1.800* | 850 |
| | 0,0 m | kg | 2.300* | 2.300* | 2.200* | 1.450 | 2.050* | 1.050 | 1.900* | 800 |
| | -1,5 m | kg | 2.350* | 2.350* | 2.250* | 1.450 | 2.100* | 1.000 | 1.950* | 800 |

with 464 kg additional counterweight

NOTE:

Ratings are based on ISO standard 10567. Rated loads do not exceed 87% of hydraulic lift capacity or 75% of tipping load.

- The values marked with an asterisk (*) are limited by the hydraulic capacities
- Calculations are based on the machine resting on a uniform and firm surface
- The lifting point is a hypothetical hook placed behind the bucket.

BUCKET RANGE

| Bucket capacity (ISO 7451) | m ³ | 0,077 | 0,109 | 0,181 | 0,235 | 0,282 |
|-------------------------------------|----------------|-------|-------|-------|-------|-------|
| Bucket width (without cutting edge) | mm | 350 | 450 | 550 | 650 | 750 |
| Bucket width (with cutting edge) | mm | 450 | 550 | 650 | 750 | 825 |

WORKING RANGE

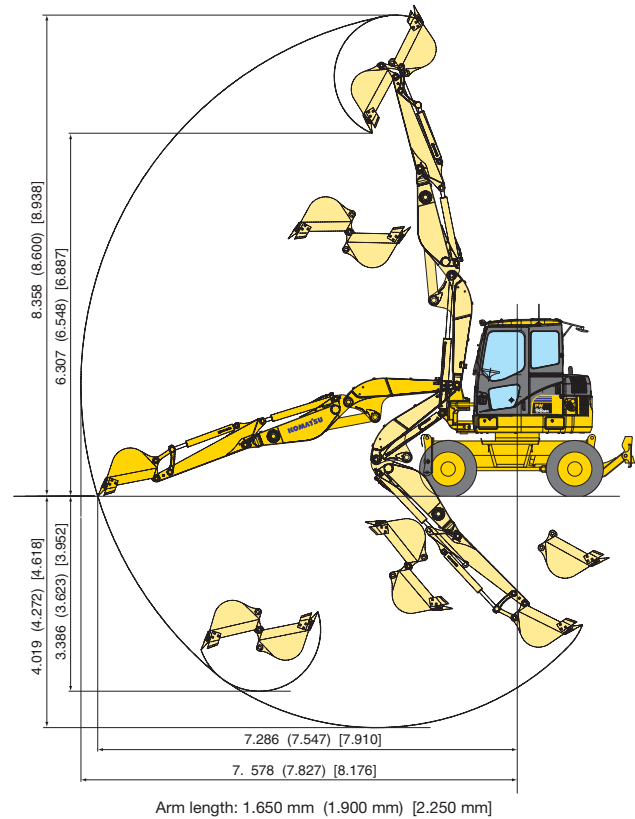

DIMENSIONS

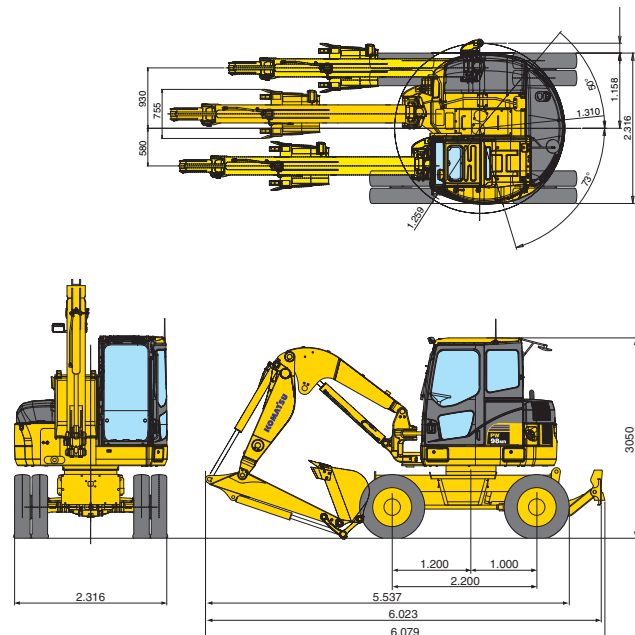

Midi-Excavator

PW98MR-6

Standard and Optional Equipment

ENGINE

| | |
|--|---|
| Komatsu S4D95LE-3 direct injection, water cooled, turbocharged diesel engine | ● |
| Alternator 24 V/60 A | ● |

TYRES

| | |
|----------------------|---|
| Twin tyres 8.25-20 | ● |
| Single tyres 18-19.5 | ○ |

HYDRAULIC SYSTEM

| | |
|---|---|
| Adjustable element for attachment | ● |
| 2nd and 3rd auxiliary hydraulic line for 3 simultaneous movements and hydraulic quick-coupler | ○ |
| Relieve valve for attachment circuit | ○ |
| Final cocks on attachment circuit | ○ |

LIGHTING SYSTEM

| | |
|----------------------------------|---|
| Working light on boom | ● |
| Rear working light on cab | ○ |
| 1 front working light on cab | ○ |
| 2 front working lights on cab | ○ |
| Additional working light on boom | ○ |

CAB

| | |
|--|---|
| Cab with heating | ● |
| Adjustable seat with safety belt | ● |
| Instrumentation including: | |
| - hour meter | |
| - LCD fuel level indicator | |
| - LCD engine water temperature indicator | |
| - two travel speed | ● |
| - working mode selection | |
| - indicators: air filter clogging, oil pressure, generator, hydraulic oil filter, engine pre-heating, selected speed | |
| 24 V internal electric plug | ● |
| Air conditioning | ○ |
| Radio | ○ |

SERVICE AND MAINTENANCE

| | |
|--|---|
| Double-element air filter | ● |
| KOMTRAX™ - Komatsu satellite monitoring system | ● |

SAFETY EQUIPMENT

| | |
|-----------------------------------|---|
| Hose burst valve on boom cylinder | ● |
| Overload warning device | ● |
| Horn | ● |
| Rearview mirror (right side) | ● |
| Lateral mirror (left side) | ● |
| Lateral mirror (right side) | ○ |
| Travel acoustic alarm | ○ |
| Safety valve for digging arm | ○ |
| Rotating beacon | ○ |

ATTACHMENTS

| | |
|--|---|
| Stabilisers and/or blade with safety valve | ○ |
| Bucket range (350 - 750 mm) | ○ |
| 1.500 mm ditch cleaning bucket | ○ |
| 1.650 mm ditch digging bucket (52°) | ○ |

OTHER EQUIPMENT

| | |
|--|---|
| Two-piece boom with cylinder protection | ● |
| 1.650 mm digging arm | ● |
| 4-wheel steering | ● |
| Automatic parking brake | ● |
| Swing lock | ● |
| Digging arm (1.900/2.250 mm) | ○ |
| Additional counterweight (215 or 464 kg) | ○ |
| Fuel supply pump | ○ |

Further work equipment, accessories and special application arrangements on request

Other attachments on request

- standard equipment
- optional equipment

Your Komatsu partner:

KOMATSU

**Komatsu Europe
International NV**
Mechelsesteenweg 586
B-1800 VILVOORDE (BELGIUM)
Tel. +32-2-255 24 11
Fax +32-2-252 19 81
www.komatsu.eu

WESS005603 12/2010

Materials and specifications are subject to change without notice.
KOMATSU is a trademark of Komatsu Ltd. Japan.