

KOMATSU

WA
250PZ

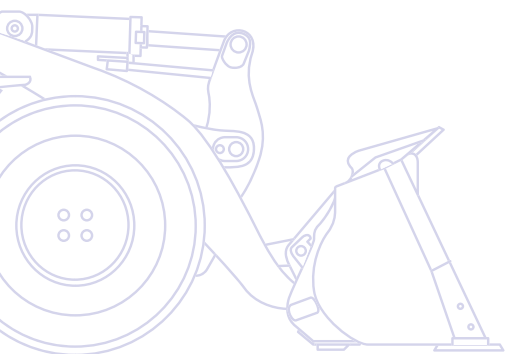

Wheel Loader **WA250PZ-6**



ENGINE POWER
104 kW / 139 HP @ 2.000 rpm

OPERATING WEIGHT
12.325 - 13.055 kg

BUCKET CAPACITY
2,0 - 2,5 m³

Courtesy of Machine.Market

Walk-Around

The highly versatile Komatsu WA250PZ-6 wheel loader features a perfect mix of power, comfort and reliability. With the new ecot3 engine and an advanced hydrostatic drive line it offers exceptional tractive force and ultra-low fuel consumption. This machine sets new efficiency standards for wheel loaders.

High productivity & low fuel consumption

- High-torque and low-consumption ecot3 Komatsu engine
- Highly efficient hydrostatic drive line
- Best-in-class dumping height and maximum stability
- Boom suspension system for minimum spillage (option)
- Meets EU Stage IIIA and EPA Tier III

Versatile PZ-linkage

- Combines advantages of Z-linkage with parallel lift
- Large break-out force for easy bucket fill
- High tilt forces for controlled work with heavy attachments
- Parallel lift for fast pallet handling
- Superb visibility to front attachments



WA250PZ-6

ENGINE POWER
104 kW / 139 HP @ 2.000 rpm

OPERATING WEIGHT
12.325 - 13.055 kg

BUCKET CAPACITY
2,0 - 2,5 m³



First-class operator comfort

- Large SpaceCab™ cab with increased leg space
- Outstanding 360° visibility
- PPC-Multifunction lever
- Deluxe heated, air-suspended driver seat
- Electronically controlled air conditioning



Easy maintenance

- Wide core radiator with auto reversible fan speeds up cleaning
- Factory fitted automatic lubrication system (optional)
- Large gull-wing doors for easy access to service points
- Equipment Management and Monitoring System (EMMS)
- Robust components with a long service life

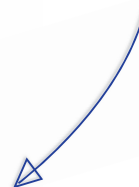

KOMTRAX

Komatsu Satellite
Monitoring System

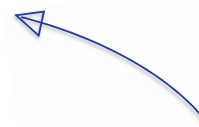

Responsive hydrostatic drive line (HST)

- Instant response for fast loading cycles
- Easy control in confined areas
- Advanced traction control system for best traction and minimized tyre wear
- Top speed selection for increased safety

High Productivity & Low Fuel Consumption

Low consumption ecot3 engine

The Komatsu SAA6D107E-1 engine provides high torque, a better performance at low speed and low fuel consumption. This ecot3 engine features a new combustion chamber design with optimised ignition and combustion timing. The operating pressure of the new common rail system was increased for improved injection and fuel efficiency. The air-to-air intercooler reduces the temperature of the compressed air supplied by the turbo charger to the cylinders, and further improves fuel consumption.

Highly efficient hydrostatic drive line

The electronically controlled variable pump and 2-motor system allow highly efficient and powerful operation. At low speeds both motors are engaged to provide highest torque. Bucket filling and scooping are easy, as maximum rim pull is provided from zero travel speed. At high speeds, a clutch cuts off the low speed motor to eliminate drag and achieve excellent fuel efficiency.

Meets EU Stage IIIA

The new Komatsu ecot3 engine technology reduces NOx and particle emissions, fuel consumption and noise level. The Komatsu SAA6D107E-1 is certified for EPA Tier III and EU Stage IIIA emission regulations.

Best in class dumping height

The long lifting frame allows the best in class dumping height of 2,96 m with a straight tipping load of 9,45 tonnes (with 2,2 m³ universal bucket, measured to the cutting edge). With this working range, loading high feeders or trucks becomes easy and fast.

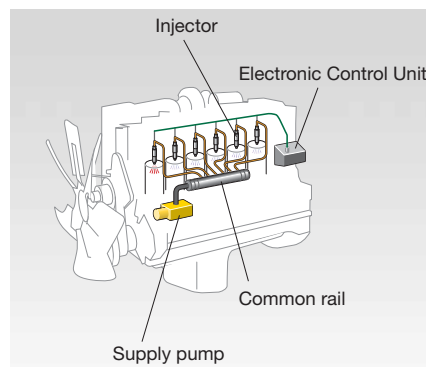

High pressure common rail fuel injection

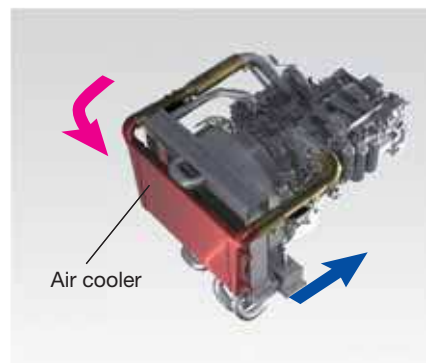

Air-to-air charge air cooling system

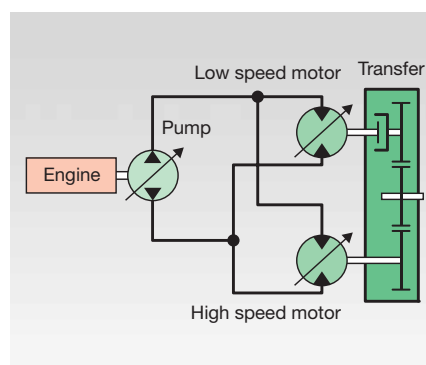

Electronically controlled HST



Courtesy of Machine.Market



Boom suspension system (optional)

The boom suspension system reduces the shocks in the boom when driving with loads. Material can be transported at higher speeds with minimum spillage. When travelling below 7 km/h, the boom suspension is automatically deactivated for precise pallet loading into trucks.



Versatile PZ-Linkage

One machine for all applications

The new Komatsu WA250PZ-6 is the right choice for any job. The parallel lift Z-bar = "PZ" linkage combines the advantages of the approved Z-bar linkage with the features of parallel lift kinematics.

Easy bucket fill

The superior break-out force of the WA250PZ-6 turns loading into a child's play, even for an untrained operator. More experienced workers will also appreciate this feature, particularly when working with high density material such as heavy soil or aggregate.

Parallel lift for fast pallet handling

With the parallel lift PZ-linkage, pallet moving becomes easy. The parallelism has been optimized for safe work over the entire lifting range. The excellent visibility of the front attachment allows an easy pick-up of pallets and precise work when loading onto trucks.



Excellent visibility of the front attachment



Controlled work with heavy attachments

With the new linkage design, tilting forces reach the optimal level, especially at maximum boom height. This is essential for controlling large attachments such as log grapples or oversized buckets. The new WA250PZ-6 is the ideal choice for working with heavy attachments.



Responsive Hydrostatic Drive Line (HST)

Instant response for fast loading cycles

The Komatsu HST drive line features exceptional responsiveness that results in quick acceleration and fast forward/reverse changes. The drive line reacts to the operator's command without any time lag and instantly provides torque at the wheels. This allows for fast loading cycles and higher productivity.

Easy control in confined areas

The self braking effect of the HST drive line slows down the machine when the accelerator pedal is released. Uncontrolled rolling is prevented, and safety is greatly improved, especially when working in confined spaces or inside industrial buildings. In addition, brake wear is practically eliminated.

Advanced traction control system

The new advanced traction control system lets the driver adjust traction precisely to working conditions. The provided rim pull can be set to 5 different levels to prevent spinning wheels on any ground conditions, even when operating on snow. Constant traction increases productivity and reduces tyre wear and cost.

Top speed selection for increased safety

The variable shift control allows setting the top speed for improved safety and precision. The top speed can be adjusted to the working conditions: max speed for fast travelling between jobsites, reduced speed to increase the safety when working on jobsites with high traffic or for working in confined spaces. In position 1, the speed can be continuously adjusted between 4 and 13 km/h with the fine control. This allows constant low driving speeds that are perfectly adjusted to applications such as lawn mowing or milling jobs.





First-Class Operator Comfort

Large SpaceCab™

Komatsu's SpaceCab™ is among the most spacious in its class and it has been lengthened for greater leg room. It offers a driving convenience comparable to that of a passenger car. The cabin is mounted on viscose shock absorbers that guarantee low vibrations and sound levels.

Outstanding 360° visibility

The large frameless windscreen ensures an optimum view of the bucket and tyres. The slanted engine hood gives an excellent view to the rear.

Air-suspended, heated seat

The high comfort air-suspended seat, with lumbar support and multiple possibilities for adjustments, ensures the operator's well being during the entire working day. All seats are equipped with a heating function to provide an easy start on cold days.

Electronically controlled air conditioning

With the electronically controlled air conditioning fitted as standard, the operator can feel at ease regardless of the outside temperature. Concentration and productivity stays high all day.

Additional comfort

Further standard features of the Komatsu SpaceCab™ are the CD radio, a "hot and cool" box for beverages, several storage spaces and adjustable arm rests on both sides.

PPC-Multifunction lever

The servo-assisted multi-function lever with an integrated forward/reverse switch allows the simplest and most comfortable operation of the equipment. With one hand the driver can simultaneously control the attachment and switch between forward and reverse. As an additional option, the third spool can be controlled by two buttons on the multi-function lever for easy work with a grapple or a high dump bucket.





Easy Maintenance

Easy access to service points

For easy and safe opening the gull-wing doors are supported by gas springs. The large doors give a convenient access from ground level to all daily service points. With long service intervals and all filters collected in a centralised arrangement, machine downtime is reduced to a minimum.

State-of-the-art monitoring

The equipment management and monitoring system (EMMS) is clearly structured and easy to read. If a malfunction occurs, it is immediately displayed as plain text in the selected language. The system features an error memory, a self-diagnosis function and a display of service intervals. The EMMS gives timely notification of required oil and filter replacements. All information can also be accessed off-site via KOMTRAX™. The operator and customer service engineer are constantly informed about the machine's state so that problems can be prevented before they occur.

Wide core radiator with auto reverse fan

A wide core radiator prevents clogging even when working in a dusty environment. To minimize manual cleaning, a reversible fan blows dust out, automatically or on demand. The “automatic reverse” function allows to set the cleaning length and the time between cleaning to adjust perfectly to the working conditions.

Factory fitted automatic lubrication system (optional)

The automatic lubrication system reduces the daily service work to the absolute minimum. Robust piping ensures consistent lubrication and operating reliability, and significantly increases the machine's service life. The system is electronically monitored and features a signal light in the cabin.





Komatsu Satellite Monitoring System



KOMTRAX™ is a revolutionary machine tracking system designed to save you time and money. You can now monitor your equipment anytime and anywhere. Use valuable machine data received via the KOMTRAX™ web site to optimise your maintenance planning and machine performances.

KOMTRAX™ can assist you with:

Full machine monitoring

Get detailed operation data to know when your machines are used and how productive they are.

Total Fleet Management

Keep track of the location of your machines at all times and discourage unapproved usage or theft.

Complete machine status

Receive warnings, alerts and cautions, via a web site or by e-mail, to help with maintenance planning and for longer machine life.

For further details on KOMTRAX™, please ask your Komatsu dealer for the latest KOMTRAX™ brochure.





Machine working time - With the "daily working record" chart, get precise engine running time data: when your machine was started and when it was shut down, as well as total engine running time.



Maintenance planning - To increase productivity and improve maintenance planning, alerts indicate when items such as filters or oil must be replaced.



Fleet location - The machine list instantly locates all your machines, even those in other countries.



Machine tracking during transport - When your machine is transported, KOMTRAX™ sends travel messages to the web site or by e-mail to inform you of its progress, and confirms when it reaches its destination.



Alarm notifications - You can receive notification of alarms both via the KOMTRAX™ website and by e-mail.



Added security - The "engine lock" feature allows to program when a machine's engine can be started. And with "geo-fence", KOMTRAX™ sends notification every time your machine moves in or out of a predetermined operating area.



Robust and Reliable

Designed and built by Komatsu

The engine, hydraulics, power train, front and rear axles are original Komatsu components. All these components are subject to the highest quality standards right down to the smallest screw. All components are fully co-ordinated with one another, thus offering the maximum efficiency and reliability.

Heavy-duty axles

The heavy-duty axles allow exceptional service life even under the toughest working conditions. As standard, the WA250PZ-6 is equipped with torque proportional differentials for work on good ground conditions such as on concrete yards or roads. The optional limited slip differentials are most suitable for soft and slippery ground like sand or wet soil.

HST drive line with overrun protection

The hydrostatic drive line is equipped with an overrun protection that electronically limits the top speed when driving downhill and thus ensures the long service life of the power train and the drive line system.



Wet multi-disc service brake

The multi-disc service brake is encapsulated and runs in an oil bath. The brake stays clean and operates at low temperature for increased service intervals and a long lifetime.



Robust torsion-resistant main frame

The frame design with hinge points far apart guarantees the high stability for the overall construction and reduces bearing stress in the torsional ranges.

Working gear division

Komatsu wheel loaders combined with a wide range of genuine Komatsu attachments provide the perfect solution for any industry sector. For special applications our “Working Gear” division offers purpose-built machines and attachments. The tailor made solutions allow high performance and outstanding reliability even under toughest conditions.

Waste handling

We adapt our wheel loaders to the different conditions that exist on waste handling job sites. Along with heavy duty attachments, we offer solutions to protect your machine against damage.



Timber industry

A wide range of options specifically developed for the timber industry are available: log grapples, wood chip buckets, cameras, as well as various protections and pre-filters.

Agriculture

Availability is the key. Komatsu offers special protections - even against corrosion - for constant work in aggressive environments such as fertilizer handling.



Buckets and Attachments

The WA250PZ-6 is outstanding due to its versatility. Whether used industrially in structural or civil engineering, earthmoving, road construction, waste recycling, agriculture, forestry or the timber

industry, in landscaping companies or in community services, the right solution is always available for your requirements.

The optional 4-point quick-coupler adds increased versatility to the

machine and thus allows high-intensity operation.

Examples from the comprehensive range of original attachments are:



Universal bucket

This type of bucket is impressive because of its excellent penetration and loosening properties and its good material holding properties. This universal bucket can be equipped with flush mount adapters and interchangeable teeth.



Earthmoving bucket

The earthmoving bucket with a one-piece bucket bottom is suited both for earthworks and loading cohesive material. The slanted sides give powerful penetration. It is equipped either with flush mount adapters and interchangeable teeth or also with a rear removable edge.



Stock pile bucket

The stock pile bucket is the right solution for handling loose and relatively light materials. The straight sidewalls ensure a high bucket capacity, the rear edge makes levelling and cleaning up jobsites easy. This stock pile bucket can be equipped with flush mount adapters and interchangeable teeth or a bolt-on cutting edge.



Hydraulic quick-coupler

The WA250PZ-6 can change attachments in a matter of seconds with the HD hydraulic quick-coupler, available as optional equipment.



Mulch grab bucket

Perfectly suited for picking up bulky and compressible materials like gardening or plastic waste, etc. Without the side plates, this bucket can be used also as a grapple.



High dump bucket

For maximum dumping heights with light materials like coal or woodchips. The dump cylinders are located either inside or outside the bucket.

ENGINE

Model	Komatsu SAA6D107E-1 Common rail direct injection, water-cooled, emissionised, turbocharged, after-cooled diesel
Engine power at rated engine speed	2.000 rpm
ISO 14396	104 kW / 139 HP
Max. torque / engine speed	627 Nm / 1.400 rpm
No. of cylinders	6
Bore x stroke	107 x 124 mm
Displacement	6,69 ltr
Lubricating system	Gear pump, pressure feed lubrication filter
Filter	Main-flow filter
Electrical system	24 V
Battery	2 x 110 Ah
Alternator	60 A
Air-filter type	Dry-air filter with automatic dust emission and preliminary purification including a dust display

TRANSMISSION

Drive system	Electronically controlled hydrostatic transmission, switchable in all directions under full power. Fixed ratio gearbox. Variable speed limiter
Hydrostatic pump	1 variable piston pump
Hydrostatic motor	2 variable piston motors
Speed ranges (forwards/backwards)	4/4
Max. travel speeds (forwards/backwards) (Tyres 20.5 R25)	
1. speed range	4-13 km/h
2. speed range	13 km/h
3. speed range	18 km/h
4. speed range	38 km/h

CHASSIS AND TYRES

System	4-wheel drive
Front axle	HD axle, semi-floating, fixed type, TPD-differential, (LSD-differential optional)
Rear axle	HD axle, semi-floating, centre-pin support, 24° swing angle, TPD-differential, (LSD-differential optional)
Reduction gear	Spiral bevel gear
Differential	Straight bevel gear pair
Final drive	Planetary gear in an oil bath
Tyres	20.5 R25 (standard)

SERVICE REFILL CAPACITIES

Cooling system	22 ltr
Fuel tank	186 ltr
Engine oil	23 ltr
Hydraulic system	67 ltr
Axle (both front and rear axle)	18 ltr
Transfer	5,0 ltr

BRAKES

Operating brakes	Completely hydraulic dual-circuit system, running in oil bath, multi-disc brakes on all wheels, service-free
Parking brake	Operated mechanically, running in oil bath, multi-disc brake, service-free
Emergency brake	Uses the parking brake

HYDRAULIC SYSTEM

Hydraulic pump	Gear pump
Working pressure (max)	206 bar
Circulating capacity of the hydraulic pump	110 + 78 ltr/min
No. of boom/bucket cylinders	2/1
Type	Double-action
Bore diameter x stroke	
Boom cylinder	130 x 717 mm
Bucket cylinder	170 x 480 mm
Hydraulic control lever	Servo-controlled, single lever
Hydraulic cycle with rated load bucket filling	
Raise time	5,7 s
Lowering time (empty)	3,3 s
Dumping time	1,6 s

STEERING SYSTEM

System	Articulated frame steering
Type	Completely hydraulic power steering
Steering angle to either side	40°
Steering pump	Gear pump
Working pressure	186 bar
Pumping capacity	110 ltr/min
No. of steering cylinders	2
Type	Double-action
Bore diameter x stroke	70 x 453 mm
Smallest turn (outer edge of the tyre 20.5 R25)	5.240 mm

CABIN

Two-door SpaceCab™ in conformity with ISO 3471 with ROPS (roll over protective structure) in conformity with SAE J1040c and FOPS (falling object protective structure) in conformity with ISO 3449. The air-conditioned pressurised cabin is mounted upon hydrobearings and is noise dampened.

ENVIRONMENT

Engine emissions	Fully complies with EU Stage IIIA and EPA Tier III exhaust emission regulations
Noise levels	
LwA external	104 dB(A) (2000/14/EC Stage II)
LpA operator ear	72 dB(A) (ISO 6396 dynamic test)
Vibration levels (EN 12096:1997)*	
Hand/arm	≤ 2,5 m/s ² (uncertainty K = 0,20 m/s ²)
Body	≤ 0,5 m/s ² (uncertainty K = 0,11 m/s ²)

* for the purpose of risk assessment under directive 2002/44/EC, please refer to ISO/TR 25398:2006.

Dimensions & Performance Figures

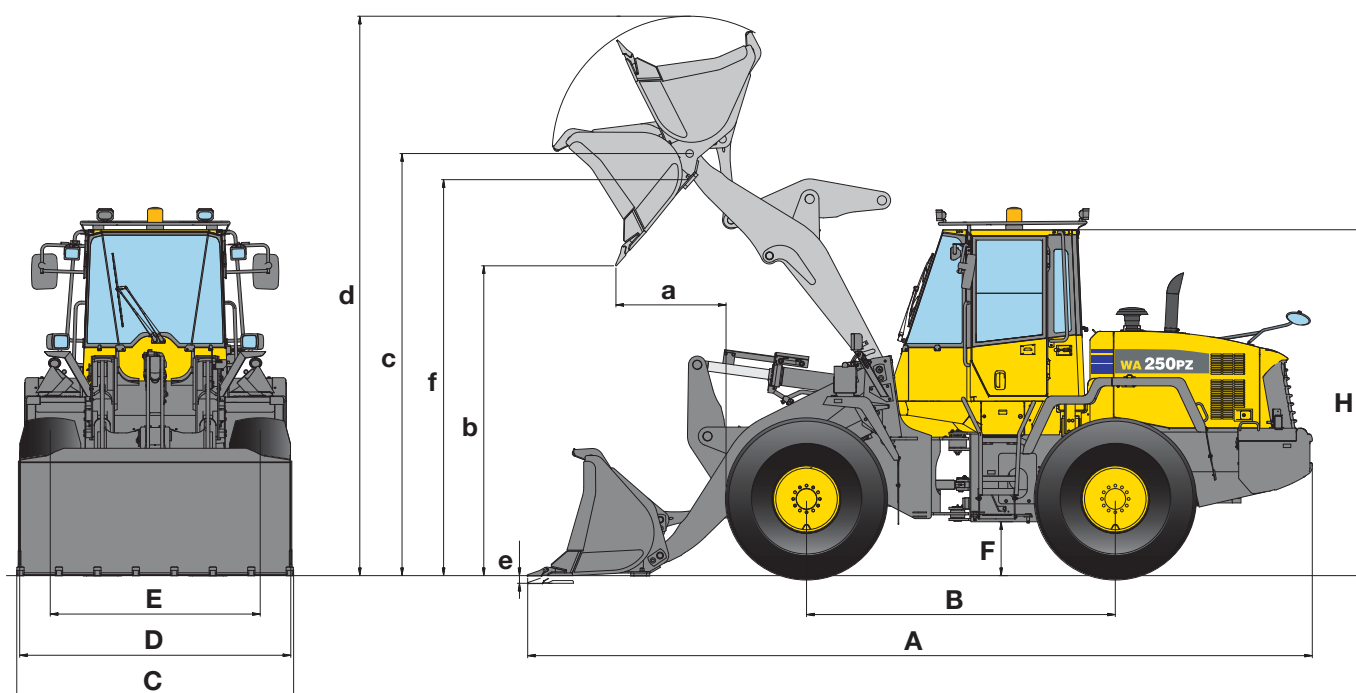

MEASUREMENTS AND WORKING SPECIFICATIONS

		Earthmoving		Stockpile		Universal	
		w. teeth	w. BOC	w. teeth	w. BOC	w. teeth	w. BOC
Bucket mount (direct/quick-coupler)		direct	direct	direct	direct	direct	direct
Bucket capacity (heaped, ISO 7546)	m³	2,2	2,3	2,3	2,5	2,1	2,2
Sales code		C32	C33	C22	C23	C02	C03
Material density (max)	t/m ³	1,75	1,6	1,6	1,45	1,80	1,7
Bucket weight	kg	1.105	1.110	1.130	1.135	990	995
Static tipping load, straight	kg	9.380	9.335	9.305	9.245	9.520	9.450
Static tipping load, 40° articulated	kg	8.190	8.150	8.120	8.070	8.330	8.265
Break-out force hydraulic	kN	136,2	128,9	131,5	124,8	136,8	129,5
Lifting capability hydr. at ground level	kN	130,7	131	131,3	131,7	130,6	131,1
Operating weight	kg	12.440	12.445	12.465	12.470	12.325	12.330
Turning radius at corner of tyres	mm	5.240	5.240	5.240	5.240	5.240	5.240
Turning radius at bucket edge	mm	5.845	5.800	5.850	5.805	5.845	5.800
a Reach at 45°	mm	1.075	935	1.100	960	1.070	930
b Dump height at 45°	mm	2.855	2.955	2.830	2.935	2.860	2.960
c Hinge pin height	mm	3.965	3.965	3.965	3.965	3.965	3.965
d Height top edge of bucket	mm	5.290	5.290	5.290	5.290	5.230	5.230
e Digging depth	mm	125	150	125	150	125	150
f Max. loading height at 45°	mm	3.680	3.680	3.680	3.680	3.680	3.680
A Overall length, bucket grounded	mm	7.380	7.230	7.415	7.265	7.375	7.225
B Wheelbase	mm	2.900	2.900	2.900	2.900	2.900	2.900
C Bucket width	mm	2.550	2.540	2.550	2.540	2.550	2.540
D Width over tyres	mm	2.470	2.470	2.470	2.470	2.470	2.470
E Track width	mm	1.930	1.930	1.930	1.930	1.930	1.930
F Ground clearance	mm	465	465	465	465	465	465
H Overall height	mm	3.200	3.200	3.200	3.200	3.200	3.200

All measurements with tyres 20.5 R25

BOC: bolt-on cutting edge



CHANGE IN DATA CAUSED BY:

		Tyres L2	Tyres L5
Operating weight	kg	-330	+680
Static tipping load, straight	kg	-220	+450
Static tipping load, 40° articulated	kg	-195	+400
Overall length, bucket grounded	mm	---	---
Reach at 45°	mm	+70	-20
Dump height at 45°	mm	-75	+25
Width over tyres	mm	-75	+0
Overall height	mm	-75	+25

HIGH-LIFT

Earthmoving		Stockpile		Universal		Stockpile		Universal	
w. teeth	w. BOC	w. teeth	w. BOC	w. teeth	w. BOC	w. BOC	w. BOC	w. BOC	w. BOC
QC	QC	QC	QC	QC	QC	direct	QC	direct	QC
2,1	2,3	2,3	2,5	2,0	2,1	2,3	2,5	2,3	2,1
C62	C63	C66	C67	C42	C43	C26	C67	C06	C43
1,7	1,55	1,55	1,4	1,8	1,7	1,40	1,20	1,45	1,45
1.080	1.085	1.105	1.110	955	960	1.180	1.115	1.035	960
8.985	8.955	8.955	8.905	9.125	9.105	8.150	7.575	8.385	7.770
7.800	7.765	7.765	7.720	7.935	7.915	6.945	6.415	7.165	6.600
111,9	107,2	108,9	104	112,4	107,4	104	85	110	88
125,2	125,9	126,9	124	128,5	126,4	90	84	93	86
13.025	13.030	13.050	13.055	12.900	12.905	12.795	13.105	12.650	12.950
5.240	5.240	5.240	5.240	5.240	5.240	5.240	5.240	5.240	5.240
5.905	5.855	5.915	5.865	5.905	5.855	6.020	6.090	6.000	6.075
1.230	1.095	1.255	1.120	1.230	1.090	1.040	1.200	1.010	1.170
2.710	2.815	2.685	2.790	2.715	2.815	3.355	3.210	3.390	3.235
3.965	3.965	3.965	3.965	3.965	3.965	4.385	4.385	4.385	4.385
5.450	5.450	5.450	5.450	5.390	5.390	5.710	5.870	5.645	5.805
115	140	115	140	115	140	130	120	130	120
3.680	3.680	3.680	3.680	3.680	3.680	4.105	4.105	4.105	4.105
7.585	7.440	7.620	7.620	7.580	7.435	7.730	7.945	7.680	7.905
2.900	2.900	2.900	2.900	2.900	2.900	2.900	2.900	2.900	2.900
2.550	2.540	2.550	2.540	2.550	2.540	2.540	2.540	2.540	2.540
2.470	2.470	2.470	2.470	2.470	2.470	2.470	2.470	2.470	2.470
1.930	1.930	1.930	1.930	1.930	1.930	1.930	1.930	1.930	1.930
465	465	465	465	465	465	465	465	465	465
3.200	3.200	3.200	3.200	3.200	3.200	3.200	3.200	3.200	3.200

Dimensions & Performance Figures

FORK TINES

Sales code	C57	
Fork tine length	mm	1.200
A Max. reach at ground level	mm	965
B Max. reach	mm	1.630
C Max. reach at max. stacking height	mm	725
a Max. height fork-carrier	mm	4.765
b Hinge pin height	mm	3.965
c Max. stacking height	mm	3.820
d Height of forks at maximum reach	mm	1.820
Max. tipping load, straight	kg	7.005
Max. tipping load, articulated	kg	6.120
Max. payload as per EN 474-3, 80%	kg	4.895
Max. payload as per EN 474-3, 60%	kg	3.670
Weight in working order with fork tines	kg	12.510

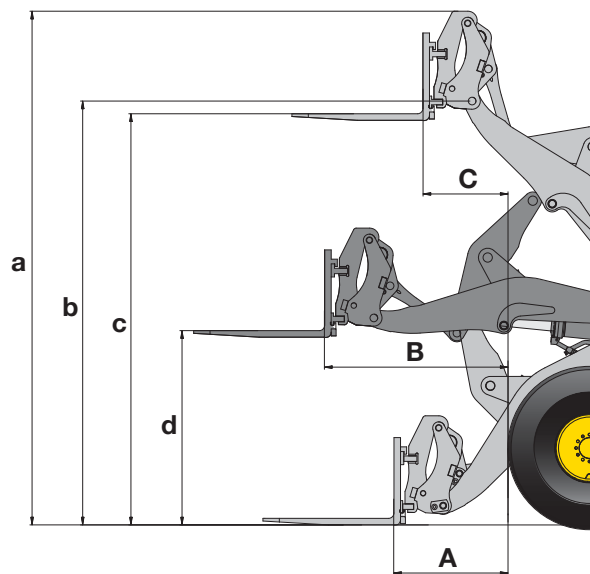

HIGH-DUMP BUCKET

Type	A	B
Sales code	Q39	Q41
Bucket capacity (heaped, ISO 7546)	m ³ 3,8	3,1
Material density	t/m ³ 0,8	1,0
Bucket width	mm 2.740	2.550
Bucket weight without teeth	kg 1.600	1.875
A Reach at 45°	mm 1.530	1.450
a Height top edge of bucket	mm 6.380	6.340
b Hinge pin height	mm 5.090	4.950
c Max. loading height at 45°	mm 4.940	4.800
d Dump height at 45°	mm 4.650	4.510

Type A: dump cylinders located inside bucket
 Type B: dump cylinders located outside bucket

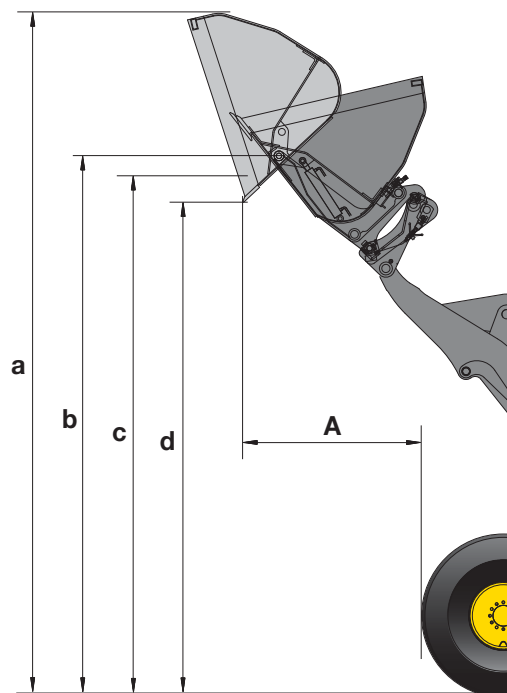

TYPICAL MATERIAL DENSITY – LOOSE (IN kg/m³)

Basalt	1.960	Gravel, unscreened	1.930	Sandstone	1.510
Bauxite, Kaolin	1.420	Gravel, dry	1.510	Slate	1.250
Earth, dry, ex store	1.510	Gravel, dry, 6-50 mm	1.690	Slag, broken	1.750
Earth, wet, excavated	1.600	Gravel, wet, 6-50 mm	2.020	Stone, crushed	1.600
Gypsum, broken	1.810	Sand, dry, loose	1.420	Clay, natural	1.660
Gypsum, crushed	1.600	Sand, damp	1.690	Clay, dry	1.480
Granite, broken	1.660	Sand, wet	1.840	Clay, wet	1.660
Limestone, broken	1.540	Sand and clay, loose	1.600	Clay and gravel, dry	1.420
Limestone, crushed	1.540	Sand and gravel, dry	1.720	Clay and gravel, wet	1.540

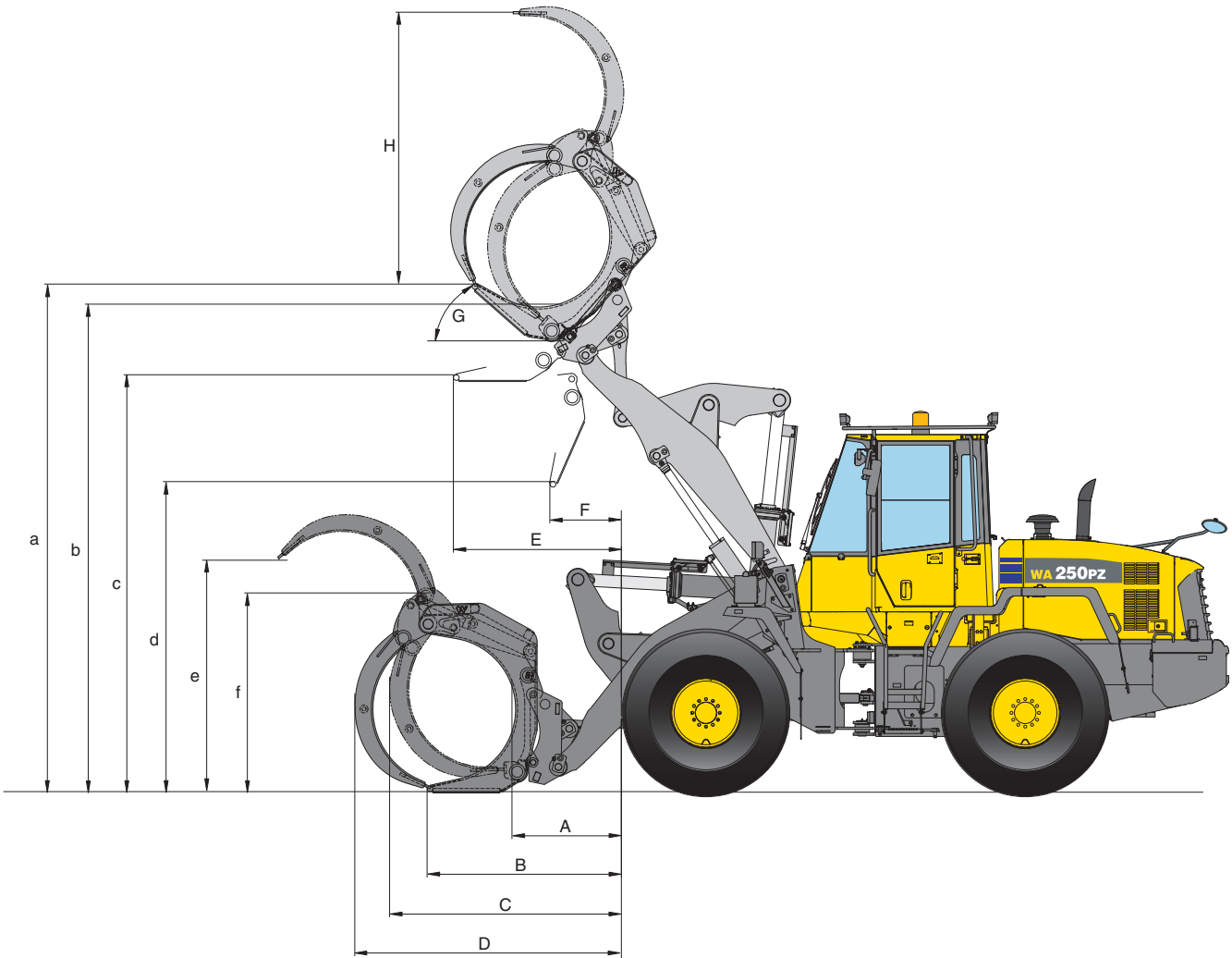

LOG GRAPPLE

Sales code		Q55
Area	m ²	1,4
Max. payload	kg	4.330
Grapple weight	kg	900

A	mm	960
B	mm	1.750
C	mm	2.085
D	mm	2.405
E	mm	1.490
F	mm	690
G Max. tilt-back angle	°	52
H (at tilt-back angle 30°)	mm	2.100
a (at tilt-back angle 30°)	mm	4.730
b (at tilt-back angle 30°)	mm	4.400
c	mm	3.735
d	mm	2.830
e	mm	2.100
f	mm	1.740

Wheel Loader

WA250PZ-6

Standard and Optional Equipment

ENGINE

Komatsu SAA6D107E-1 turbocharged common rail direct injection diesel engine	●
EU Stage IIIA/EPA Tier III compliant	
Fuel filter with water separator	●
Engine cooling fluid corrosion resistor	●
Alternator 60 A	●
Starter motor 4,5 kW/24 V	●
Batteries 2 × 110 Ah/2 × 12 V	●

TRANSMISSION AND BRAKES

Electronically controlled HST with 2-motor system	●
Speed control with fine adjustment in 1st speed range	●
Traction control system (TCS)	●
Fully hydraulic brake system	●
Combined brake/inching pedal	●
20 km/h limited hydrostatic driveline	○
Creeping function: 1 - 4 km/h speed control	○

CHASSIS AND TYRES

Heavy-duty axles	●
TPD-differential front and rear	●
Power train guard	●
Limited-slip differential (LSD) front and rear	○
Tyres 20.5 R25 L2, L3, L5	○

HYDRAULIC SYSTEM

2-spool main control valve	●
PPC control, 1-lever (Multi-function lever)	●
Automatic return-to-dig	●
Automatic boom kick-out	●
3-spool main control valve	○
PPC fingertip control, 2 or 3 levers	○
PPC Multi-function lever with add. 3rd spool lever control	○
Electr. 3rd spool actuation on joystick	○
Biodegradable oil for hydraulic system	○

CABIN

Spacious double door driver's cab to DIN/ISO	●
ROPS/FOPS frame according to SAE	●
Air-suspended, heated seat	●
Electr. controlled air conditioning	●
CD radio	●
Hot and cool box	●
All-round tinted glazing	●
Front laminated glass	●
Heated rear window	●
Rear window wiper	●
Sun visor	●
Seat belt (EU standard)	●
Adjustable steering column	●
12 V power supply	○
Fire extinguisher	○

SERVICE AND MAINTENANCE

Wide core radiator	●
Hydrostat-driven swing-out radiator fan with automatic reversing function	●
EMMS (Equipment Management Monitoring System) with self-diagnostic function and maintenance display	●
KOMTRAX™ - Komatsu satellite monitoring system	●
Tool-set	●
Turbo II air pre-cleaner, cyclone type	○
Automatic central lubrication	○

SAFETY EQUIPMENT

Emergency steering system	●
Horn	●
Vandalism protection	●
Back-up alarm	●
Front screen protective grid	○
Beacon light	○
Electronic anti-theft lock	○
Electronic anti-theft lock with master key for fleet owners	○
Battery main switch	○
Additional convex rear view mirror	○
Roof rail and step light	○

LIGHTING SYSTEM

2 halogen main headlights	●
2 spotlights at front and rear	●
Reversing light	●
Additional lights front and rear	○
Xenon working lights	○

OTHER EQUIPMENT

Z-bar boom with parallel movement (PZ-kinematics)	●
Counterweight	●
Additional side counterweights	●
Electronically controlled load stabilizer (ECSS)	○
Special custom colour	○
Anti-corrosion specification	○
Waste handling equipment on request	○
Cold area kit (engine and cab pre-heating)	○
Roof rail	○

ATTACHMENTS

Hydraulic quick-coupler (incl. additional side counterweights, large size)	○
Universal buckets	○
Earthmoving buckets	○
Stock pile buckets	○
High-dump buckets	○
Log grapples	○
Fork carrier and tines	○
Waste handling high-dump bucket 2,5 m ³ with protection grid	○
Waste handling bucket 3,2 m ³	○
Waste handling mulch grapple bucket 2,2 m ³	○
Light material bucket 3,5 m ³	○
Crane arm	○

Buckets direct or quick-coupler mount, with teeth or BOC (bolt-on cutting edge).

Further equipment on request

The WA250PZ-6 is equipped in accordance with the safety regulations of the machinery guidelines 89/392 EWG ff and EN474.

- standard equipment
- optional equipment

Your Komatsu partner:

KOMATSU

**Komatsu Europe
International NV**
Mechelsesteenweg 586
B-1800 VILVOORDE (BELGIUM)
Tel. +32-2-255 24 11
Fax +32-2-252 19 81
www.komatsu.eu

VESS002703 12/2010

Materials and specifications are subject to change without notice.
KOMATSU is a trademark of Komatsu Ltd. Japan.