

KOMATSU®

WA500-6 With Tier 3 Engine

NET HORSEPOWER
263 kW **353 HP** @ 1900 rpm

OPERATING WEIGHT
32470 - 33570 kg
71,585 - 74,010 lb

BUCKET CAPACITY
4.5 - 6.3 m³ **5.9 - 8.2 yd³**

WA
500

W
H
E
E
L
L
O
A
D
E
R



Photos may include optional equipment.

WALK-AROUND

High Productivity & Low Fuel Consumption

- High performance SAA6D140E-5 engine
- Low fuel consumption
- Dual-mode engine power select system
- Automatic transmission with shift timing select system
- Lock-up Torque Converter
- Variable displacement piston pump & CLSS
- Increased bucket capacity

Excellent Operator Environment

- Automatic transmission with ECMV
- Low-noise designed cab
- Electronic controlled transmission lever
- Variable transmission cut-off system
- Engine RPM set system with auto decel
- EPC (Electronic Pilot Control) levers
- Large ROPS/FOPS integrated cab
- Telescopic / tilt steering column



KOMTRAX™

KOMTRAX equipped machines can send location, SMR and operation maps to a secure website utilizing wireless technology. Machines also relay error codes, cautions, maintenance items, fuel levels and much more.

Environmentally Friendly

- EPA Tier 3, EU stage 3A and Japan emissions certified
- Low exterior noise
- Low fuel consumption

NET HORSEPOWER
263 kW 353 HP @ 1900 rpm

OPERATING WEIGHT
32470 - 33570 kg
71,585 - 74,010 lb

BUCKET CAPACITY
4.5 - 6.3 m³ 5.9 - 8.2 yd³

Increased Reliability

- Reliable Komatsu designed and manufactured components
- Sturdy main frame
- Maintenance-free, fully hydraulic, wet disc service and parking brakes
- Hydraulic hoses use flat face O-ring seals
- Sealed DT connectors for electrical connections



Easy Maintenance

- “EMMS” (Equipment Management Monitoring System)
- Ease of radiator cleaning
- Modular radiator core system

PRODUCTIVITY FEATURES



ecology & economy - technology 3

Komatsu's new "ecot3" engines are designed to deliver optimum performance under the

toughest of conditions, while meeting the latest environmental regulations. This engine is EPA Tier 3, EU Stage 3A and Japan emissions certified; "ecot3" - ecology and economy combine with Komatsu technology to create a high performance engine without sacrificing power or productivity.

High Performance SAA6D140E-5 Engine

Electronic Heavy Duty Common Rail fuel injection system provides optimum combustion of fuel.

This system also provides fast throttle response to match the machine's powerful tractive effort and fast hydraulic response.

Net: 263 kW **353 HP**

Low Emission Engine

This engine is EPA Tier 3, EU stage 3A and Japan emissions certified, without sacrificing power or machine productivity.

Low Fuel Consumption

The fuel consumption is greatly reduced because of the low-noise, high-torque engine and large-capacity torque converter. This matched combination provides maximum efficiency in the low-speed range.

Dual-Mode Engine Power Select System

This wheel loader offers two selectable operating modes—E and P. The operator can adjust the machine's performance with the selection switch.

- **E Mode:** This mode provides maximum fuel efficiency for general loading.
- **P Mode:** This mode provides maximum power output for hard digging operation or hill climb.

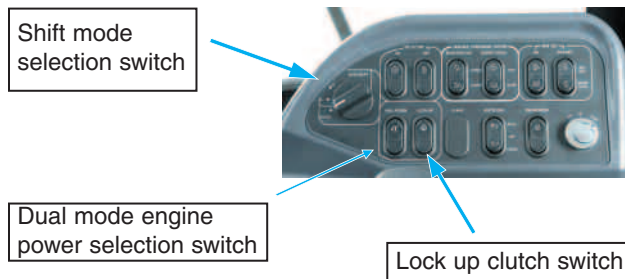

Automatic Transmission with Mode Select System

This operator controlled system allows the selection of manual shifting or two levels of automatic shifting modes (low and high). The operator can match the machine's operating requirements with optimum performance efficiency. This system is controlled with a dial on the right control panel.

- **Manual:** The transmission is fixed to the gear speed and selected with the gear lever.
- **Auto Low:** Low mode provides smooth gear shifting at low engine speeds suitable for general excavating and loading while offering reduced fuel consumption.
- **Auto High:** High mode provides maximum rim pull and fast cycle times by shifting the transmission at high engine speeds. This mode is suitable for hill-climb and load and carry operations

Lock-up Torque Converter

The Komatsu designed lock-up torque converter provides increased production efficiency, reduced cycle times and optimum fuel savings in load and carry or hill-climb operations..

Variable displacement piston pump & CLSS

New design variable displacement piston pump combined with the Closed-center Load Sensing System delivers hydraulic flow just as the job requires preventing wasted hydraulic pressure. Minimized waste loss contributes to better fuel economy.

- **New Variable Displacement Piston Pump:** The pump delivers only necessary amounts minimizing waste loss.

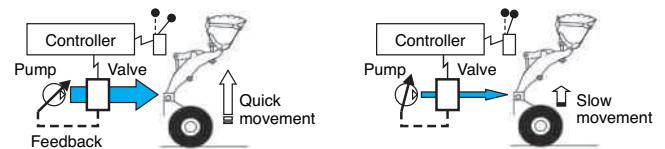

- **Fixed Displacement Piston Pump:** The pump delivers the maximum amount at any time and the unused flow is disposed.

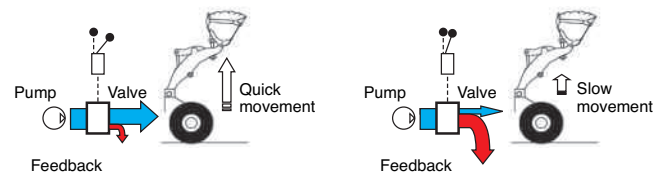



Increased Bucket Capacity Matches With One Class Higher Dump Truck

The WA500-6 can load 32 ton(40 Short ton) trucks with the standard boom.



Dumping Clearance: 3295 mm 10'10"
Dumping Reach: 1500 mm 4'11"
 (5.6 m³ 7.3 yd³ bucket with B.O.C.E.)

Long Wheelbase/Articulation Angle of 40°

The wide tread and the long wheelbase provide improved machine stability in both longitudinal and lateral directions. Since the articulation angle is 40°, the operator can work efficiently even on the tightest job sites.

Tread	2400 mm	7'10"
Wheelbase	3780 mm	12'5"
Minimum turning radius (center of outside tire)	6430 mm	21'1"

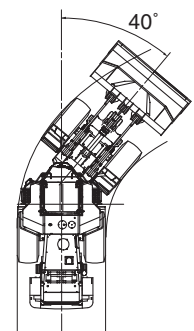

RELIABILITY

Komatsu Components

Komatsu manufactures the engine, torque converter, transmission, hydraulic units and electric parts on this wheel loader. Komatsu loaders are manufactured with an integrated production system under a strict quality control system.

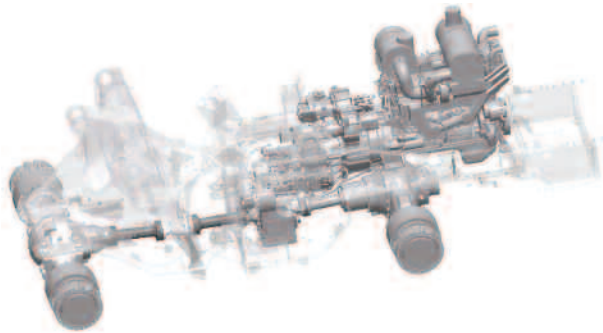

Wet multi-disc brakes and fully hydraulic braking system results in lower maintenance costs and higher reliability. The wet disc service and parking brakes are fully sealed and adjustment-free to reduce contamination, wear and maintenance. Added reliability is designed into the braking system by the use of two independent hydraulic circuits providing hydraulic backup should one of the circuits fail. If the brake oil pressure drops, a warning lamp flashes and an alarm sounds intermittently. If the brake pressure continues to drop, the parking brake is automatically applied.

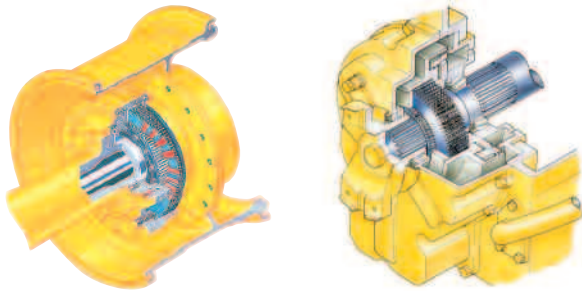

High-rigidity Frames

The front and rear frames along with the loader linkage have high rigidity to withstand repeated twisting and bending loads to the loader body and linkage. Both the upper and lower center pivot bearings use tapered roller bearings for increased durability.

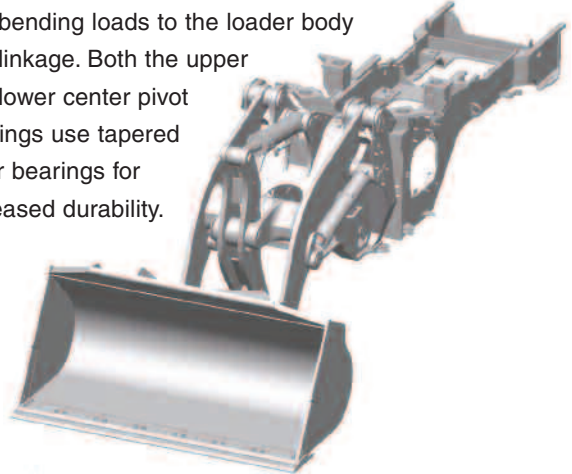

Flat Face-to-Face O-Ring Seals

Flat face-to-face O-ring seals are used to securely seal all hydraulic hose connections and to prevent oil leakage. In addition, buffer rings are installed to the head side of the all-hydraulic cylinders to lower the load on the rod seals and maximize the reliability.

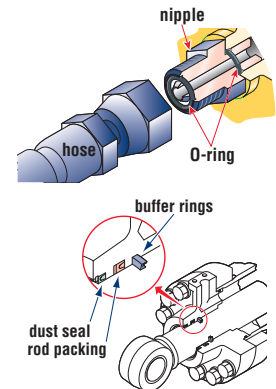

Sealed DT Connectors

Main harnesses and controller connectors are equipped with sealed DT connectors providing high reliability, dust and corrosion resistance.



EASY MAINTENANCE



Photo may include optional equipment.

EMMS (Equipment Management Monitoring System)

Komatsu's new main monitor keeps the operator informed of all machine functions at a glance. The monitor is located behind the steering wheel and displays different machine functions including fluid/filter change intervals and troubleshooting memory display functions. The main gauges are analog type for easy viewing and other functions utilize lighted symbols or LCD readouts.



Maintenance Control and Troubleshooting Functions

- **Action code display function:** If an abnormality occurs, the monitor displays action details on the character display at the bottom center of the monitor.
- **Monitor function:** Controller monitors engine oil level, pressure, coolant temperature, air cleaner clogging, etc. If the controller finds only abnormalities, the error is displayed on the LCD.
- **Replacement time notice function:** Monitor informs replacement time of oil and filters on the LCD when replacement intervals are reached.
- **Error code memory function:** The monitor stores the error codes associated with the abnormalities for effective troubleshooting.

Gull-wing Type Engine Side Doors Open Wide

Ground level engine service checks are made easy with the gas spring assisted full side opening gull-wing doors



Modular radiator core system

The modular radiator core is easily accessed without having to remove the entire radiator assembly.



Reversible Hydraulic Radiator Fan



The Komatsu cooling system is isolated from the engine to provide more efficient cooling and easier cleaning. The variable speed hydraulic fan is reversible to allow the operator to quickly clean out the cooling system by turning on a switch located on the right side control panel. The variable speed hydraulic fan is temperature activated to provide cooling on demand and reduce fuel consumption.

OPERATOR COMFORT

Easy Operation

Automatic Transmission with ECMV

Automatic transmission with ECMV (Electronically Controlled Modulation Valve) automatically selects the proper gear speed based on travel speed, engine speed, and other travel conditions. The ECMV system engages the clutch smoothly to prevent lags and shocks when shifting. This system provides efficient machine operation and a comfortable ride.

- **Kick-down**

switch: Consider this valuable feature for added productivity. With the touch of a finger, the kick-down switch

automatically downshifts from second to first when beginning the digging cycle. It automatically upshifts from first to second when the direction control lever is placed in reverse. This results in increased rim pull for better bucket penetration and reduced cycle times for higher productivity.

- **Hold switch:** Auto shift is selected and if the operator turns on this switch when the lever is at the 3rd or 4th gear speed position, the transmission is fixed to that gear speed.

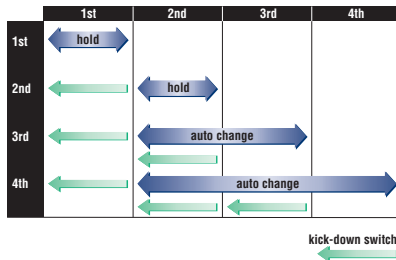

Electronically Controlled Transmission Lever



The Komatsu two-lever electronic shift control levers provide easy gear selection and directional changes. The transmission levers can be operated with removing the operators hand from the steering wheel, allowing

improved comfort and control. Solid state electronics and conveniently located direction and gear shift controls make this possible. Automatic shifts in ranges two through four keep production high and manual shifting at a minimum.

Variable Transmission Cut-off System

The operator can select the transmission cut-off pressure desired for the left brake pedal using the switch located on the right-side control panel.

- Higher cut-off pressure allows the transmission to remain engaged at higher engine rpm/hydraulic pressure for increased performance in ramp loading and stockpiling operations.
- Lower cut-off pressure disengages the transmission at lower rpm/hydraulic pressure for more fuel efficient operation on level surfaces



- 1: Cut-off ON/OFF switch
- 2: Cut-off adjustment switch
- 3: Boom positioner switch
- 4: Bucket digging angle control switch
- 5: RPM set ON/OFF switch
- 6: RPM set adjustment switch
- 7: Fan reverse switch
- 8: Boom control
- 9: Bucket control

Engine RPM Set System with Auto Decel

Engine Low idle RPM can be easily preset using a push button switch. The system provides auto decel for better fuel consumption.



Comfortable Operation

EPC (Electronic Pilot Control) levers

The finger control EPC work equipment levers have light operating effort and short stroke facilitating easy operation. The operator's comfort is further increased by the full large size adjustable arm rests. Combined with CLSS, this system allows the following new functions for easy and efficient operation.



- **Remote Boom Positioner with shockless stop function:** The highest and lowest position of the bucket can be set from cab to match of any truck body. Once the positioner is set, the bucket stops smoothly at the desired position without shock.
- **Remote bucket digging angle control:** The digging bucket angle can be easily set from cab to match of ground condition.

Telescopic/Tilt Steering System

The operator can both tilt and telescope the steering wheel to allow maximum comfort and control. The two-spoke steering wheel allows maximum visibility of the monitor panel and the forward work environment.



Low-noise Design

Noise at operator's ear noise level: 75 dB(A)
Dynamic noise level (outside): 109 dB(A)

The large cab is mounted with Komatsu's unique ROPS/FOPS viscous mounts. The low-noise engine, hydraulically driven fan, and hydraulic pumps are mounted with rubber cushions, and the cab sealing is improved to provide a quiet, low-vibration, dustproof with pressurizing, and comfortable operating environment. Pressurization in the cab keeps dirt out further enhancing the operators comfort.

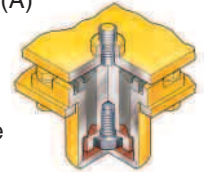

Pillar-less Large Cab

A wide pillar-less flat glass provides excellent front visibility. The wiper arm covers a large area to provide great visibility even on rainy days.

The cab layout provides the operator with a roomy, quiet and efficient work environment. The cab seat backward slide adjustment distance increases with the introduction of the front mounted air conditioning unit.

Rear-hinged Full Open Cab Door

Entry and exit into the new Komatsu cab starts with sloped staircase type steps and large diameter handrails. The large cab doors are rear-hinged to open fully offering easy entry/exit and will not hamper visibility when operating the machine with the doors latched open.



SPECIFICATIONS



ENGINE

ModelKomatsu SAA6D140E-5
 TypeWater-cooled, 4-cycle
 AspirationTurbocharged, aftercooled, cooled EGR
 Number of cylinders6
 Bore x stroke140 mm x 165 mm **5.51" x 6.50"**
 Piston displacement15.24 ltr **930 in³**
 Governorall-speed, electronic
 Horsepower
 SAE J1995Gross 266 kW **357 HP**
 ISO 9249/SAE J1349Net 263 kW **353 HP**
 Hydraulic fan at maximum speedNet 248 kW **332 HP**
 Rated rpm1900 rpm
 Fan drive method for radiator coolingHydraulic
 Fuel systemDirect injection
 Lubrication system:
 MethodGear pump, force-lubrication
 FilterFull-flow type
 Air cleanerDry type with double elements and dust evacuator, plus dust indicator



TRANSMISSION

Torque converter:
 Type3-element, single-stage, double-phase
 Transmission:
 TypeFull-powershift, planetary type
 Travel speed: km/h **mph**
 Measured with 29.5-25 tires
 (): Lock-up clutch ON

	1st		2nd		3rd		4th	
Forward	7.7	4.8	12.5	7.8 (14.2 8.8)	22.3	13.9 (23.4 14.5)	34.9	21.7 (38.8 24.1)
Reverse	8.6	5.3 (15.9 9.9)	13.0	8.1 (15.9 9.9)	24.8	15.4 (26.2 16.3)	37.5	23.3 (43.2 26.9)



AXLES AND FINAL DRIVES

Drive systemFour-wheel drive
 FrontFixed, full-floating
 RearCenter-pin support, full-floating,
 24° total oscillation
 Reduction gearSpiral bevel gear
 Differential gearConventional type
 Final reduction gearPlanetary gear, single reduction



BRAKES

Service brakesHydraulically actuated,
 wet disc brakes actuate on four wheels
 Parking brakeWet disc brake



STEERING SYSTEM

TypeArticulated type, full-hydraulic power steering
 Steering angle40° each direction
 Minimum turning radius at
 the center of outside tire6430 mm **21'1"**



HYDRAULIC SYSTEM

Steering system:
 Hydraulic pumpPiston pump
 Capacity120 ltr/min **31.7 U.S. gal/min** at max. control flow
 Relief valve setting24.5 MPa 250 kgf/cm² **3,550 psi**
 Hydraulic cylinders:
 TypeDouble-acting, piston type
 Number of cylinders2
 Bore x stroke100 mm x 486 mm **3.9" x 19.1"**
 Loader control:
 Hydraulic pumpPiston pump
 Capacity32 ltr/min **84.8 U.S. gal/min** at rated rpm
 Relief valve setting34.3 MPa 350 kgf/cm² **4,980 psi**
 Hydraulic cylinders:
 TypeDouble-acting, piston type
 Number of cylinders—bore x stroke:
 Boom cylinder2- 160 mm x 898 mm **6.3" x 35.4"**
 Bucket cylinder1- 185 mm x 675 mm **7.3" x 26.6"**
 Control valve2-spool type
 Control positions:
 BoomRaise, hold, lower, and float
 BucketTilt-back, hold, and dump
 Hydraulic cycle time (rated load in bucket)
 Raise7.2 sec
 Dump1.7 sec
 Lower (Empty)4.2 sec



SERVICE REFILL CAPACITIES

Cooling system120 ltr **31.7 U.S. gal**
 Fuel tank473 ltr **124.9 U.S. gal**
 Engine45 ltr **11.9 U.S. gal**
 Hydraulic system337 ltr **89.0 U.S. gal**
 Axle front87 ltr **22.9 U.S. gal**
 rear81 ltr **21.4 U.S. gal**
 Torque converter and transmission76 ltr **20.0 U.S. gal**



BUCKET SELECTION GUIDE

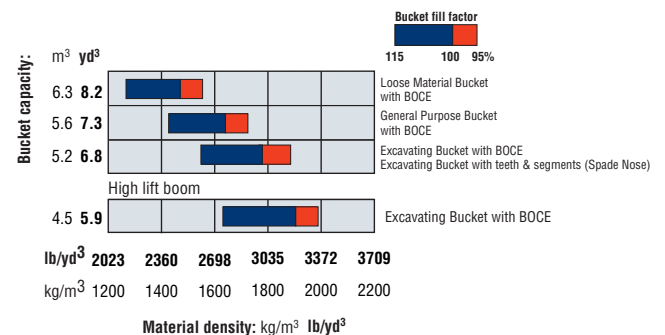

DIMENSIONS

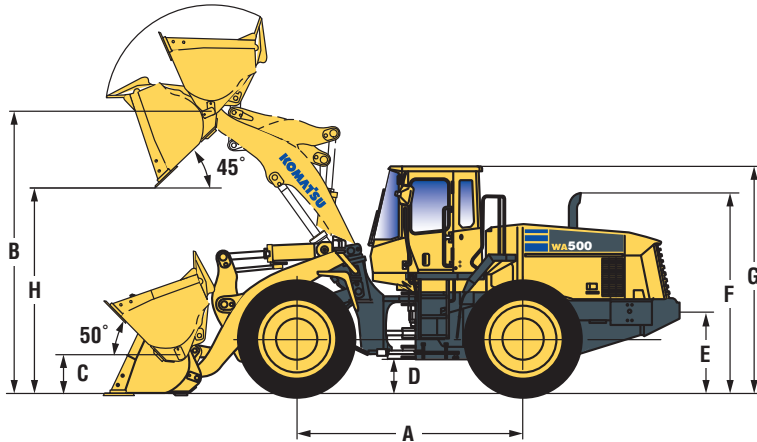

	Tread	2400 mm	7'10"
	Width over tires	3190 mm	10'6"
A	Wheelbase	3780 mm	12'5"
B	Hinge pin height max. height	Standard Boom	4755 mm 15'7"
		High Lift Boom	5166 mm 16'11"
C	Hinge pin height, carry position	575 mm	1'11"
D	Ground clearance	450 mm	1'6"
E	Hitch height	1115 mm	3'8"
F	Overall height, top of the stack	3665 mm	12'0"
G	Overall height, ROPS cab	3785 mm	12'5"

Measured with 29.5-25-22PR (L3) tires

	Standard boom			High lift boom
	General Purpose Buckets	Excavating Buckets	Loose Material Buckets	Excavating Buckets
	Straight edge Bolt-on Cutting edge	Straight edge Bolt-on Cutting edge	Straight edge Bolt-on Cutting edge	Straight edge Bolt-on Cutting edges
Bucket capacity: heaped	5.6 m ³ 7.3 yd³	5.2 m ³ 6.8 yd³	6.3 m ³ 8.2 yd³	4.5 m ³ 5.9 yd³
	struck	4.8 m ³ 6.3 yd³	4.2 m ³ 5.5 yd³	5.3 m ³ 6.9 yd³
Bucket width	3400 mm 11'2"	3400 mm 11'2"	3400 mm 11'2"	3400 mm 11'2"
Bucket weight	3110 kg 6,855 lb	2870 kg 6,325 lb	3475 kg 7,660 lb	2795 kg 6,160 lb
Dumping clearance, max. height and 45° dump angle* (H)	3295 mm 10'10"	3395 mm 11'2"	3210 mm 10'6"	3890 mm 12'9"
Reach at max. height and 45° dump angle*	1500 mm 4'11"	1400 mm 4'7"	1585 mm 5'2"	1435 mm 4'8"
Reach at 2130 mm (7') clearance and 45° dump angle	2300 mm 7'7"	2215 mm 7'3"	2350 mm 7'8"	2585 mm 8'6"
Reach with arm horizontal and bucket level	3265 mm 10'9"	3120 mm 10'3"	3385 mm 11'11"	3385 mm 11'11"
Operating height (fully raised)	6430 mm 21'1"	6415 mm 21'1"	6540 mm 21'5"	6715 mm 22'0"
Overall length	9815 mm 32'2"	9670 mm 31'9"	9935 mm 32'7"	10030 mm 32'11"
Loader clearance circle (bucket at carry, outside corner of bucket)	7650 mm 25'1"	7610 mm 24'12"	7710 mm 25'3"	7805 mm 25'7"
Digging depth: 0°	135 mm 5"	135 mm 5"	135 mm 5"	210 mm 8"
	10°	435 mm 1'5"	410 mm 1'4"	470 mm 1'7"
Static tipping load: straight	23600 kg 52,030 lb	23750 kg 52,360 lb	23100 kg 50,295 lb	21705 kg 47,850 lb
	40° full turn	20500 kg 45,195 lb	20600 kg 45,415 lb	20080 kg 44,270 lb
Breakout force	245 kN 25000 kgf 55,115 lb	268 kN 27300 kgf 60,185 lb	227 kN 23200 kgf 51,150 lb	286 kN 29140 kgf 64,245 lb
	Operating weight	32550 kg 71,760 lb	32470 kg 71,585 lb	33020 kg 72,795 lb

All dimensions, weights, and performance values based on SAE J732c and J742b standards.

Static tipping load and operating weight shown include lubricant, coolant, full fuel tank, ROPS cab, air conditioning unit, ECCS (Electronically Controlled Suspension System) and operator. Machine stability and operating weight affected by tire size and other attachments.

* At the end of tooth or B.O.C.E.



WEIGHT CHANGES

Tires or attachments	Operating weight		Tipping load straight Standard Boom		Tipping load full turn Standard Boom	
	kg	lb	kg	lb	kg	lb
Install additional counterweight	+900	+1985	+1865	+4110	+1645	+3625
Emergency steering	+70	+155	+65	+145	+55	+120
Lock-up clutch torque converter	+45	+100	+60	+130	+50	+110



STANDARD EQUIPMENT

- 2-spool valve for boom and bucket controls
- Air conditioner
- Alternator, 75 A/24 V
- Auto shift transmission with mode select system
- Back-up alarm
- Back-up lamp
- Batteries, 200 Ah/12 V x 2
- 12V converter
- Cab heater and defroster
- Counterweight (2480 kg **5,470 lb**)
- Directional signal
- ECSS (Electronically Controlled Suspension System)
- Engine, Komatsu SAA6D140E-5 diesel
- Engine pre-cleaner with extension
- Engine shut-off system, electric
- EPC fingertip control levers with automatic leveler and positioner
- Floormat
- Front fender
- Hard water area arrangement (corrosion resister)
- Hydraulic-driven fan with reverse rotation
- KOMTRAX
- Lock up torque converter
- Main monitor panel with EMMS (Equipment Management Monitoring System)
- Radiator mask, lattice type
- Rearview mirror for cab
- Rear window washer and wiper
- Rims for 29.5-25 tubeless tires (set of 4)
- ROPS/FOPS cab
- Seat, air suspension with automatic weight adjustment
- Seat belt, 76 mm **3"** wide
- Service brakes, wet disc type
- Starting motor, 11.0 kW/24 V
- Steering wheel, tiltable
- Sun visor
- Transmission, 4 forward and 4 reverse



OPTIONAL EQUIPMENT

- Additional counterweight (900 kg **1985 lb**)
- AM/FM stereo radio cassette
- Auxiliary steering (SAE)
- Fuel quick coupler
- High lift boom
- In-line filter
- Joystick steering
- Power train guard
- Limited slip differential (F&R)



ALLIED ATTACHMENTS

- Loadrite weighing system, Force Model
- Loadrite weighing system, Pro Model
- Loadrite weighing system, Pro Model with Material Management System
- Loadrite weighing system, Printer
- Lincoln Automated Lubrication System

AESS715-03

©2008 Komatsu America Corp. Printed in USA

K12(5M) C

12/08 (EV-1)

KOMATSU®