

# KOMATSU

**WH**  
**609**



Telescopic Handler

**WH609**

LIFTING HEIGHT  
9.000 mm

LIFTING CAPACITY  
3.500 kg

OPERATING WEIGHT  
8.660 kg

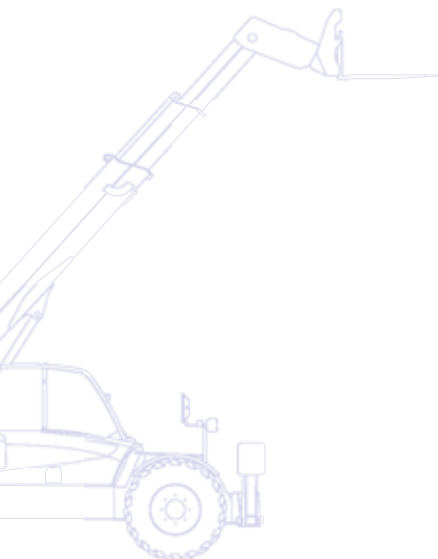

*Courtesy of Crane.Market*

# Walk-Around

The WH609 belongs to the series of Komatsu telescopic handlers, which offers:

- High quality, safety and cutting edge technology that typically characterise all Komatsu products
- Super Low Boom Profile, a new design with unique advantages in terms of stability and visibility



## Excellent visibility

- Low rear hinging point for best rear visibility
- Internal extending cylinder for best side visibility
- Low profile stabiliser frame for best front visibility
- Wide glass surface for 360° visibility

## Total comfort

- PPC joystick as std
- Spacious cab
- Exceptionally low noise
- Ergonomic layout
- Fully opening door

## Unrivalled stability

- Long wheel-base
- Frame levelling (optional)
- Wide type stabilisers (optional)
- Rear axle lock (optional)

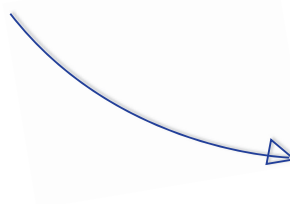
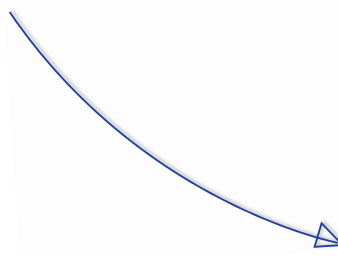

# WH609

**LIFTING HEIGHT**  
9.000 mm

**LIFTING CAPACITY**  
3.500 kg

**OPERATING WEIGHT**  
8.660 kg

## Top performance

- CLSS hydraulic for smoothest movements
- “Full Power Shift” transmission
- High travel speed



## Superior versatility and manoeuvrability

- Wide range of attachments
- Short steering radius
- 3 steering modes

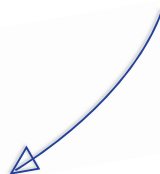

**KOMTRAX**

Komatsu Satellite  
Monitoring System



# Total Comfort



## Automotive style interior

The ROPS/FOPS cab has a modern and ergonomic layout. It is mounted on four elastic supports to reduce vibration and internal noise level. Several well distributed storage spaces in the cab maximize comfort and a state of the art LCD panel displays all the main readings. The servo-controlled joystick features a unique slider switch and allows three simultaneous boom functions: lifting, extending and tool carriage rotation. The adjustable wrist rest reduces operator fatigue.



## Wide entrance

The door opens at 180° and is made of two parts: both can be fully opened and secured for more air circulation; the lower windows enhance visibility.

# Excellent Visibility



## Control at 360°

The wide glass surfaces, the super low boom profile, the extension system with internal cylinder and the low position of the stabiliser frame (optional) give Komatsu's telescopic handlers an unrivalled all around visibility. Forks and wheels are well visible from the seat so the operator constantly has a perfect control of the working area.



## New concept frame

Thanks to the particular frame design, the boom's hinging point is the lowest in the market. The Super Low Boom Profile offers unique advantages in terms of stability and visibility, two of the most important features for telescopic handlers.



# Top Performance

The CLSS hydraulic system is a closed-centre circuit, with Load Sensing and a variable displacement pump that ensures smooth proportional and combined movements; all this guarantees maximum productivity and minimum consumption.

High lifting capacity to the maximum height and reach, both on stabilisers (optional) and on tyres. High travel speed and engine torque are set off by the standard Full Power Shift transmission.



# Unrivalled Stability

Komatsu has developed the WH series giving high importance to stability. The low position of the load centre, the innovative extending system, the wide bearing area and a huge range of stability devices, place the WH range's lifting performances at the top of its class and guarantee a high safety level for the operators.



*Optional frame levelling keeps the tool carriage horizontal, whatever the ground condition. It reaches angles of 10° on both sides and increases flexibility and lifting performances.*



*Optional wide type stabilisers guarantee highest stability on any ground type. Cylinders are well protected inside the frame.*



*An optional automatic rear axle oscillation lock enlarges the bearing area, thus increasing both lift performance and security and reducing the risk of lateral tipping. It engages automatically over a 50° boom angle.*



# Superior Versatility and Manoeuvrability



## Superior versatility

A wide choice of attachments makes this machine the ideal solution in a huge number of applications. For a list of available options see the chart on the last page.

## Perfect manoeuvrability

The wide steering angle (52°) makes the steering radius, both for tyres and forks, extremely short for a machine in this category. Moreover, when manoeuvring with a Komatsu WH machine, there is no need to worry about its rear overhang: it will always stay well within the wheel radius. 3 steering modes (two-wheel, four-wheel and crab) allow the operator to smoothly and precisely move the machine, under all conditions. To avoid accidental shifting, the steering mode selection is achieved by the simultaneous pushing of two buttons. For each axle a visual warning advises the operator when the wheels are perfectly realigned.





# Komatsu Satellite Monitoring System



Komtrax is a revolutionary machine tracking system designed to save you time and money. You can now monitor your equipment anytime and anywhere. Use valuable machine data received via the Komtrax web site to optimise your maintenance planning and machine performances.

With Komtrax, you can:

- Check when & where your machines are at work
- Be informed of unauthorized machine use or movement
- Set and receive e-mail notification for security alarms

For further details on Komtrax, please ask your Komatsu dealer for the latest Komtrax brochure.



*Machine working time - With the "daily working record" chart, get precise engine running time data: when your machine was started and when it was shut down, as well as total engine running time.*



*Fleet location - The machine list instantly locates all your machines, even those in other countries.*



*Alarm notifications - You can receive notification of alarms both via the Komtrax website and by e-mail.*



*Added security - The "engine lock" feature allows to program when a machine's engine can be started. And with "geo-fence", Komtrax sends notification every time your machine moves in or out of a predetermined operating area.*



# Specifications

## ENGINE

The engine has been developed in compliance with the strictest European standards (97/68EC 2004/26/EC – EU Stage IIIA) on the reduction of exhaust emissions.

Model ..... Komatsu SAA4D104E-2  
Type ..... 4-cycle water-cooled diesel engine  
Displacement ..... 4.485 cm<sup>3</sup>  
Bore × stroke ..... 104 × 132 mm  
No. of cylinders ..... 4  
Aspiration ..... turbo-intercooled  
Engine power  
at rated engine speed ..... 2.200 rpm  
ISO 14396 ..... 74 kW / 99,2 HP  
Max. torque/engine speed ..... 420 Nm/1.200 rpm

## HYDRAULIC SYSTEM

Type ..... CLSS (Closed Load Sensing System)  
Pump ..... variable displacement, axial piston  
Max. operating pressure ..... 260 bar  
Max. pump flow ..... 142 ltr/min  
Auxiliary hydraulic line ..... 62 ltr/min

## CONTROLS

Boom lifting, boom extension and tool carriage rotation are controlled by a PPC joystick, which allows proportional and simultaneous movements.

## CAB

The cab meets the European ROPS (ISO 3471) / FOPS (ISO 3449) safety standards. Two independent piece door; windscreen wiper; rear opening window with wiper.

Cab internal width ..... 940 mm

## BRAKE SYSTEM

Servo-assisted service brakes with 2 independent lines, acting on both axles.

Service brakes type ..... oil immersed multi-disk

Parking brakes type ..... acting on front axle service brake

## TYRES

Standard ..... 405/70-24 PR14 “all terrains”

Optional ..... 405/70-24 PR14 “agriculture”

## OPERATING PERFORMANCES

Max. lifting height ..... 9.000 mm  
Max. lifting capacity ..... 3.500 kg  
Capacity at max. height ..... 1.000 kg  
with optional frame levelling ..... 2.700 kg  
Max. forward reach ..... 5.200 mm  
Capacity at max. forward reach ..... 1.320 kg  
Drawbar pull ..... 8.890 daN  
Breakout force (ISO 3813) ..... 6.420 daN

## STEERING SYSTEM

Turning radius, four wheel steering:  
over tyres ..... 3.610 mm  
over forks ..... 5.270 mm

## TRANSMISSION

Full Power Shift transmission, permanent four wheel drive. EGS electronic control system; twist grip lever for direction and speed selection.

## TRAVELLING SPEEDS

GEAR	FORWARD	REVERSE
1st	6 km/h	6 km/h
2nd	13 km/h	13 km/h
3rd	19 km/h	25 km/h
4th	25 km/h	–
5th	38 km/h	–

## ELECTRIC SYSTEM

Voltage ..... 12 V  
Battery ..... 110 Ah  
Alternator ..... 90 A  
Starter motor ..... 3 kW

## SERVICE CAPACITIES

Fuel tank ..... 130 ltr  
Hydraulic oil tank ..... 107 ltr  
Front axle oil ..... 9 ltr  
Rear axle oil ..... 9 ltr  
Transmission oil ..... 13 ltr  
Engine oil ..... 12,8 ltr  
Coolant ..... 15 ltr

## OPERATING WEIGHT

Standard machine with forks ..... 8.660 kg



# Load Charts and Dimensions

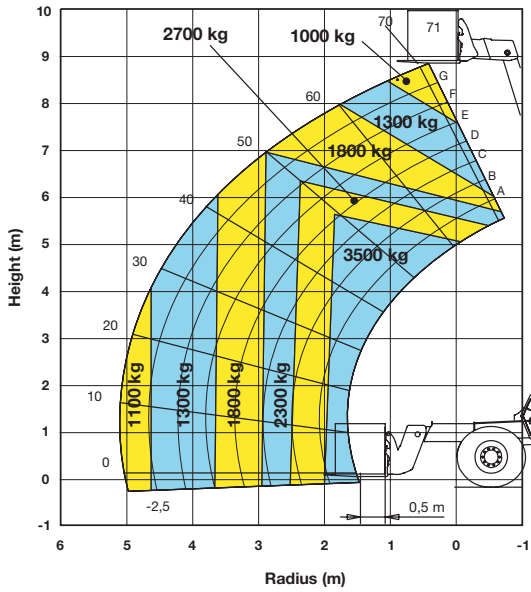

On tyres

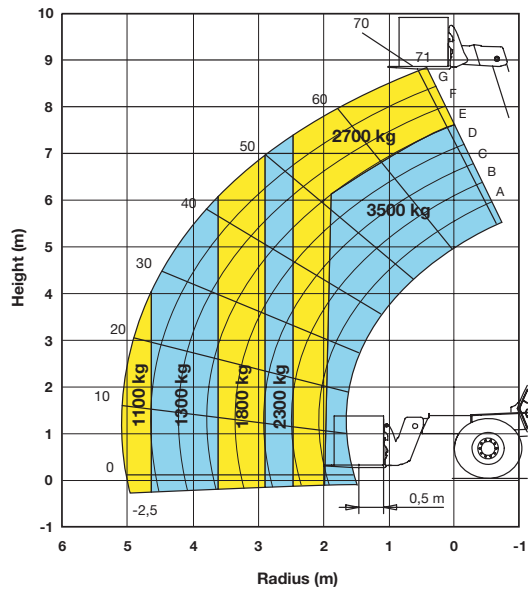

On tyres with frame levelling

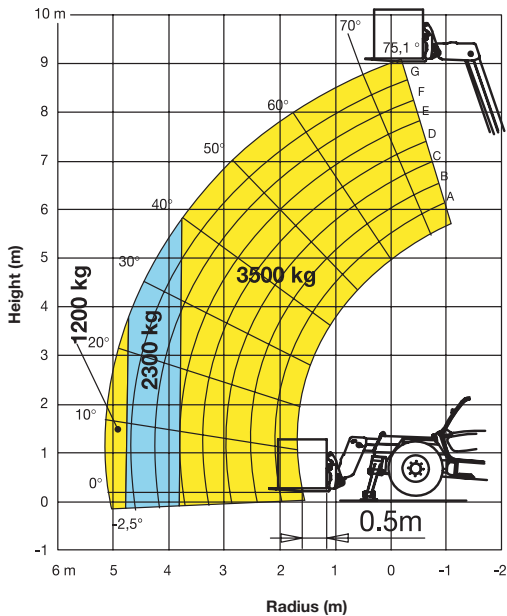

On stabilisers

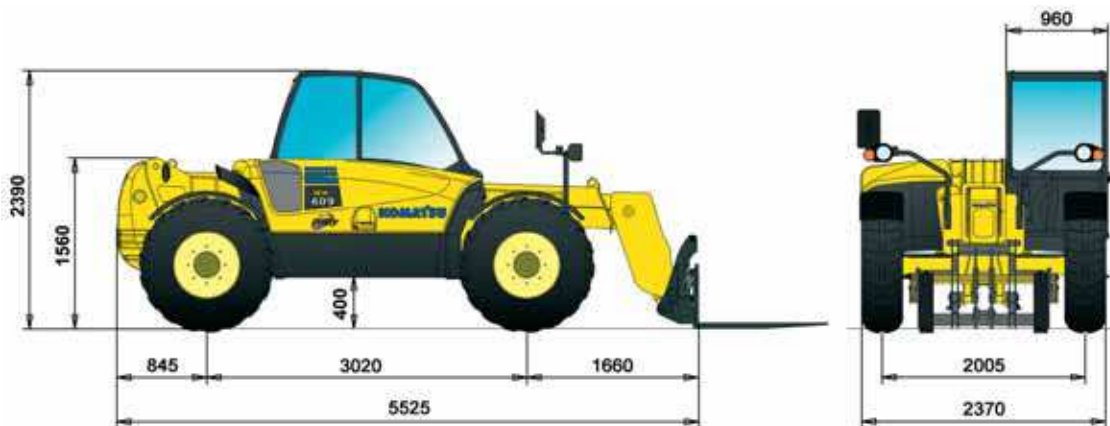

NOTE: In conformity to the standard UNI EN 1459 annex B

# Telescopic Handler

## WH609

### Standard Equipment

---

- Komatsu EU Stage IIIA compliant turbo engine
- Komtrax - Komatsu satellite monitoring system
- Air cleaner with dual element
- Fuel filter with water separator and clogging indicator
- "Full Power Shift" transmission
- CLSS hydraulic system
- Transmission oil filter
- 4 wheel steering (3 steering modes)
- Safety valves on hydraulic cylinders
- Auxiliary hydraulic circuit up to the boom head
- SLI (acoustic and visual alarm) stability control device
- Alternator 90 A
- Battery 110 Ah
- 12 V internal and external power supply
- Horn
- Back-up alarm
- ROPS/FOPS cab with heater and fan
- PPC servo-control with adjustable armrest
- Adjustable seat with safety belt
- Adjustable steering wheel
- Two piece fully opening door
- Rear opening window with wiper washer
- Front windows wiper washer
- Protection grid on the roof
- Boom angle indicator
- Mudguards
- Mechanical quick-coupler
- Floating forks
- Tyres: 405/70-24 PR14 "all terrains"

### Optional Equipment

---

- ASM (automatic stop of aggravating movements)
  - Battery 148 Ah
  - TÜV road homologation
  - Air cyclone pre-filter
  - Biodegradable hydraulic oil
  - Boom upper protection
  - Front window guard
  - Deluxe seat
  - Air conditioning
  - Rear axle lock
  - Radio pre-setting
  - Radio with CD player
  - Wiper washer on upper window
  - Boom working lights
  - Rear working light
  - Rotating beacon
  - Stabilisers
  - Frame levelling:  $\pm 10^\circ$
  - Road homologation
  - Customised paint
  - Hydraulic quick-coupler
  - Forks protection guard
  - Pre-setting for man platform
  - Hydraulic oil cooler
  - Wire coiler
  - Fuel tank protection
  - Emergency manual pump
  - Master disconnect switch
  - Tyres: 405/70-24 PR14 "agriculture"
- ATTACHMENTS:
- 4 models of man platforms with remote control
  - 1,0 m<sup>3</sup> general purpose bucket
  - 1,5 m<sup>3</sup> bucket for light material
  - 3 m<sup>3</sup> bucket for light material
  - 4x1 bucket
  - Mixing bucket
  - Hydraulic side-shift forks
  - Hook on forks
  - Carriage hook
  - Carriage winch
  - Jibs (2,3 m, 3 m, 4 m)
  - Jibs with winch (2,3 m, 3 m, 4 m)

---

Your Komatsu partner:

**KOMATSU**

**Komatsu Europe  
International NV**

Mechelsesteenweg 586  
B-1800 VILVOORDE (BELGIUM)  
Tel. +32-2-255 24 11  
Fax +32-2-252 19 81  
[www.komatsu.eu](http://www.komatsu.eu)

WESS003203 01/2009

Materials and specifications are subject to change without notice.

**KOMATSU** is a trademark of Komatsu Ltd. Japan.