

Krupp Hydraulic Truck-mounted Crane
350 GMT
450 ton Capacity



Superstructure Specifications

Boom

55 ft – 171 ft 4-section boom,
1 base + 3 power sections
(with remote lock-out system)

Telescoping cycle:

1. section 130 sec.

2. + 3. section 190 sec.

High speed:

1. section 75 sec.

2. + 3. section 105 sec.

*) Jibs

40 – 118 ft lattice extension
and inserts (for straight or
20° off-set use)

53 – 210 ft power luffing jib

Main Hoist

Axial piston motor with planetary gear
and fail-safe brake

Single line pull max.: 27560 lbs

Single line speed max.: 525 ft/min

Drum diameter: 22"

Rope diameter: 1"

Rope length: 1480 ft

*) Auxiliary Hoist

Data identical with main hoist

Hook Blocks

145 ton

*) 265, 90, 35 ton

Boom Elevation

Dual hydraulic cylinders with integral
holding valve, boom angle
from –1.5 to +82.0 degrees

Elevation cycle: 130 sec.

Swing Gear

2 axial piston motors with planetary
gear, holding and service brake,
swing speed 0 – 1 rpm variable

Engine

6 cyl. Daimler Benz OM 407 A,
water-cooled, 270 hp at 2000 rpm

Tank capacity: 80-gal. diesel

Hydraulic system

3 separate circuits: 2 axial piston pumps
with integrated infinitely variable speed
and load control,

1 4 section axial piston pump. Oil cooler.

Tank capacity: 800 gal. hydraulic oil

Control system

Infinite variation of all crane motions by
hydraulic pilot circuit, dead-man
position

Counterweight

132.280 lbs, in 4 sections, hydraulically
removable

Operator's cab

Full vision, aluminium, safety glass, fully
adjustable operator's seat with

hydraulic suspension, diesel engine
coolant heaters and ventilation system,
optional stationary heaters, complete
engine instrumentation and crane
operating controls

Safety installations

Hoist limit switch, lock valves, pressure
relief valves.

Hoist drum rotation indicator.

*) Electronic load moment safety device
with automatic cut-out and indicators
for load moment and working radius,
lowering limit switch

Carrier Specifications

Chassis

Krupp heavy-duty 8-axle carrier welded
box-type frame from high-tensile steel

Engine

12 cyl. Daimler Benz OM 424 A,
water-cooled, 530 hp at 2300 rpm

Tank capacity: 160 gal.

Transmission

Allison 5-speed automatic gear-box
MAN transfer case, 2 speed with
differential lock

Axles

1. steering axle	5. driven axle
2. driven	6. driven
steering axle	steering axle
3. steering axle	7. steering axle
4. driven axle	8. steering axle
driven axles = planetary axles	
4. + 5. axle with interaxle differential lock	

Suspension

1. – 8. axle hydropneumatic suspension
system and axle lock-outs

Tyres

16 tyres 14.00 – 24 PR 22

Steering

ZF semi-integral ball-nut hydraulic
power steering

Brakes

Service brake:
pneumatic dual-circuit acting on all
wheels

Permanent brake:
retarder of Allison automatic
transmission

Auxiliary brake:
pneumatically operated spring-loaded
brake, acting on 2nd, 3rd, 6th, 7th and
8th axle

Driver's cab

Aluminium, three-man-design with bunk,
safety glass, adjustable hydraulically
suspended seats, diesel engine coolant
heaters and ventilation system,
optional stationary heaters and
driving controls

Outriggers

Independent horizontal and vertical
hydraulic motion of each beam.

Controls on each side of chassis.

Sight level device.

Electrical equipment

Three-phase alternator 28 V/55 A

2 batteries 12 V/170 Ah

Performance

Travelling speeds: max. 42 mph
min. 0.1 mph

Gradeability: 32%

Turning radius: 54 ft

*) Optional items

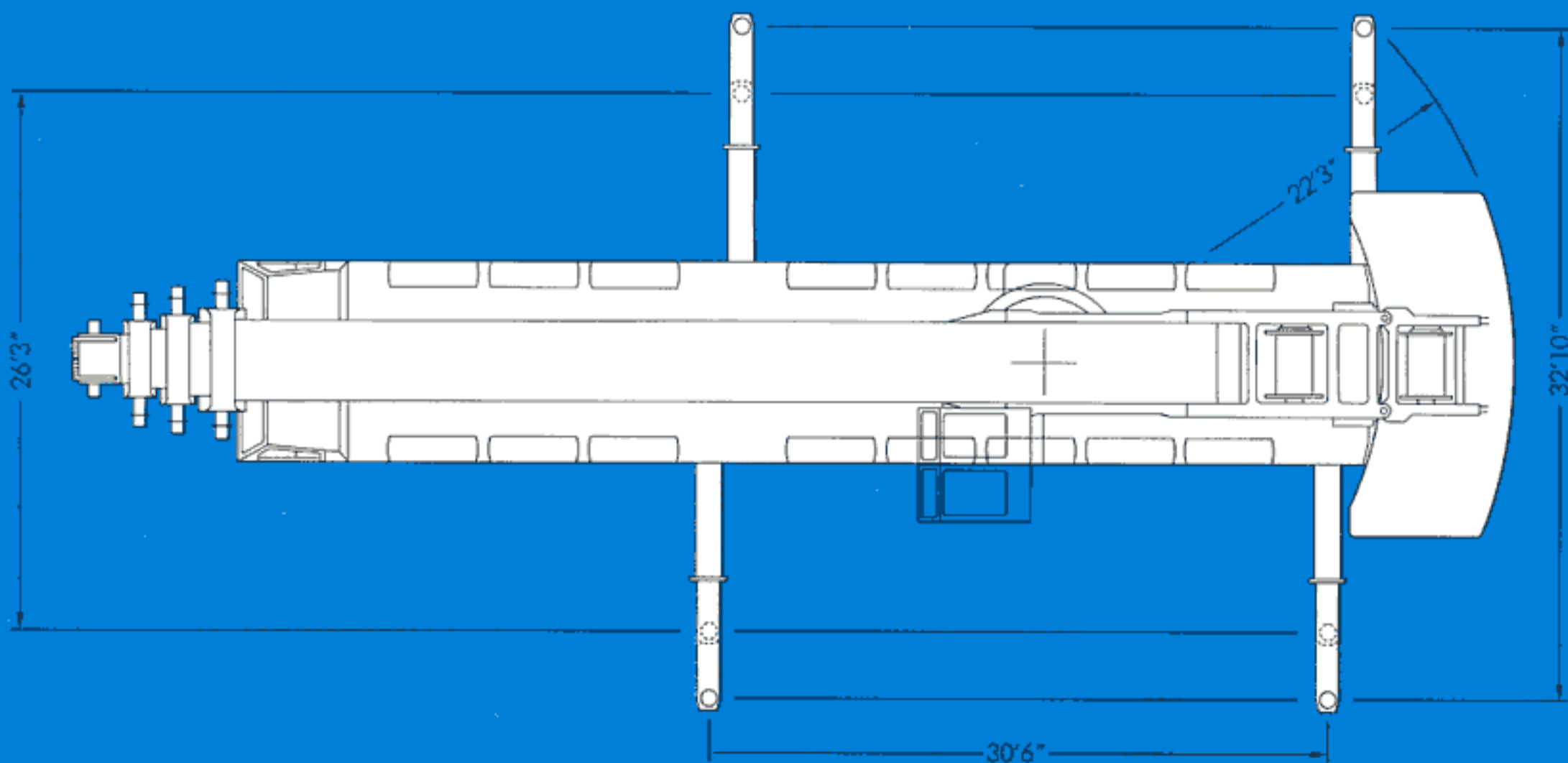
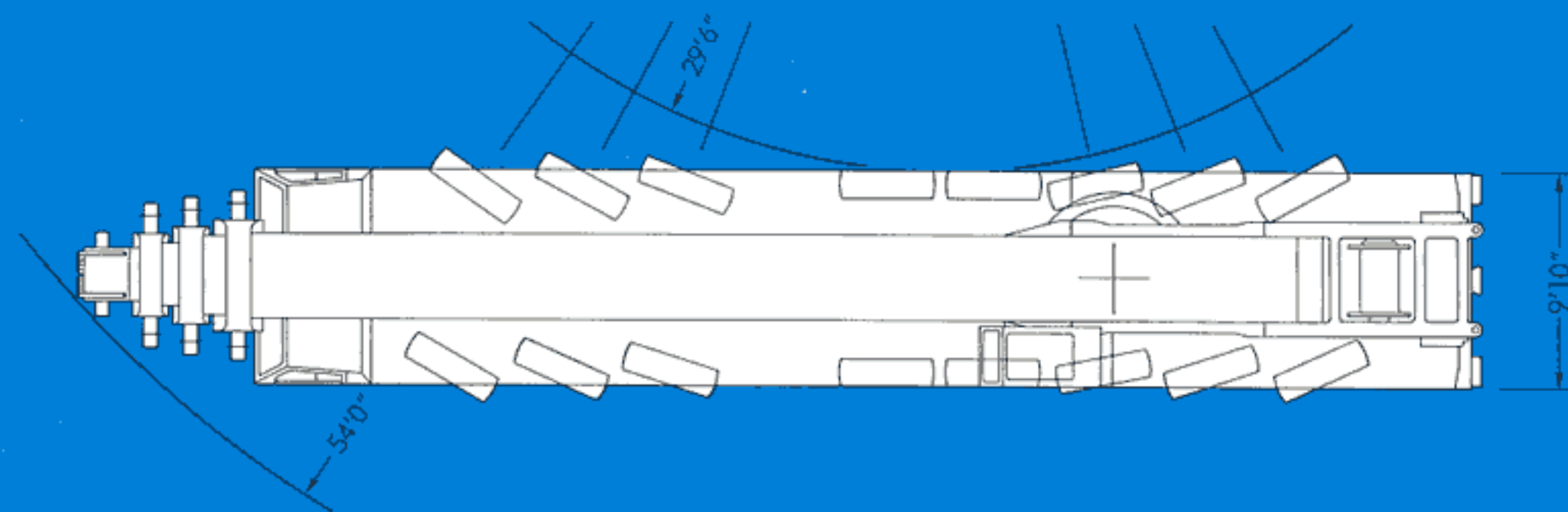
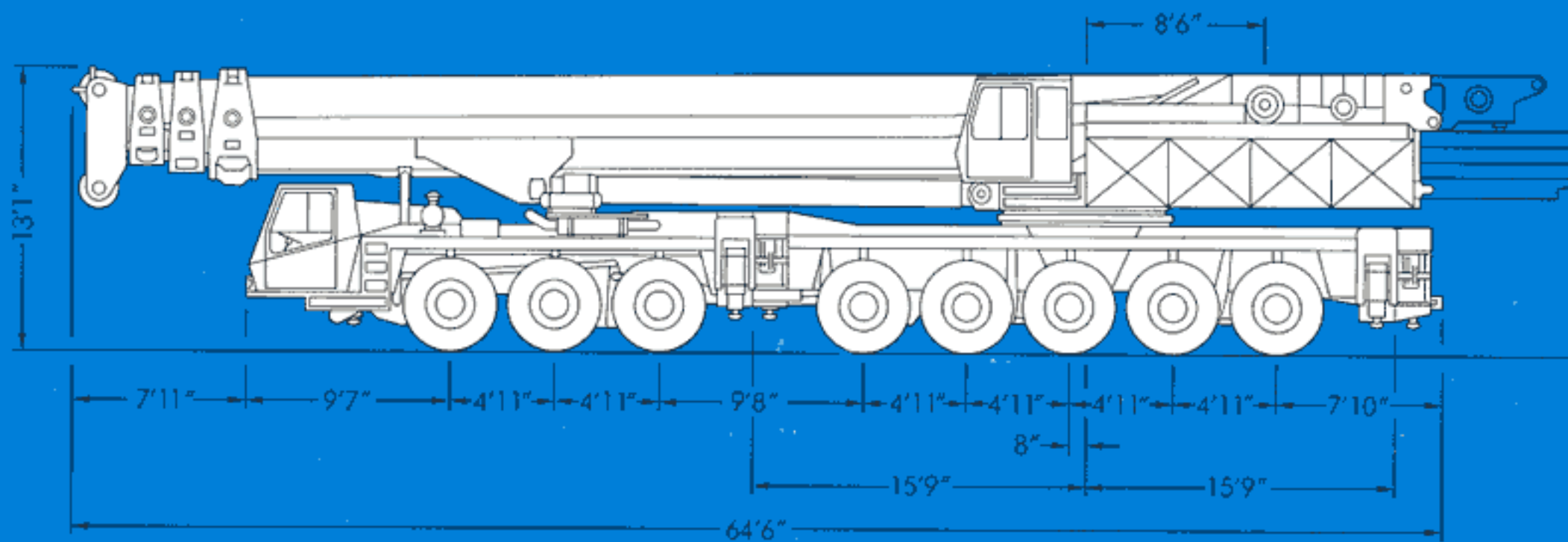

Lifting capacities in 1000 lbs on outriggers

360° Main boom

Counterweight 132.280 lbs

Counterweight 66.140 lbs

Radius (ft)	Boom length (ft)					
	55'0" *	55'0"	55'0"	94'0"	131'0"	171'0"
10	900.0*)	721.6	584.1			
15	600.2	571.5	463.2	360.9		
20	454.4	454.4	382.0	306.1		
25	364.5	364.5	324.2	268.5	185.8	
30	299.1	294.4	277.7	235.8	165.9	99.2
35	249.8	224.0	235.1	210.8	149.1	99.2
40	209.6	178.3	199.0	191.0	133.8	99.2
45				165.9	121.2	96.0
50				142.3	110.8	89.5
55				124.7	101.6	84.1
60				109.9	93.6	78.5
65				96.4	87.8	74.3
70				84.4	81.1	69.4
75				73.6	74.8	64.8
80					68.4	60.6
85					61.0	56.4
90					55.4	53.0
95					49.8	50.2
100					44.6	47.4
105					40.1	44.0
110					36.2	41.0
115						37.8
120						34.7
125						32.0
130						29.1
135						26.7
140						24.6
145						22.7
150	B	B				20.8

Radius (ft)	Boom length (ft)				
	55'0"	55'0"	94'0"	131'0"	171'0"
10	630.7	507.8			
15	485.6	404.0	328.1		
20	366.8	331.2	279.8		
25	269.3	269.4	245.6	168.8	
30	182.3	216.6	210.0	150.6	99.2
35	134.4	177.8	172.6	135.5	98.4
40	103.2	143.9	137.7	121.9	93.9
45			110.8	109.2	87.2
50			89.9	90.2	81.8
55			74.8	76.4	76.0
60			62.0	64.3	68.7
65			51.9	54.7	59.3
70			44.2	47.2	51.7
75			37.5	40.7	45.2
80				35.1	39.8
85				30.2	35.1
90				26.1	31.2
95				22.6	27.6
100				19.6	24.4
105				16.7	21.6
110				14.2	19.0
115					16.7
120					14.7
125					12.8
130					11.2
135					
140					
145					
150	B				

Notes for lifting capacities

Rated loads do not exceed 85% of tipping load with the machine properly levelled on firm ground.

360° duties – on outriggers fully extended, other than noted above (coloured lifting range).

Note counterweight required as listed in relevant lifting capacity columns.

For safe crane operation due allowance must be made to compensate for high winds, side load, pendulum action and other hazardous conditions. No side pull permitted.

Hook blocks, slings and/or boom attachments are considered part of the load, and their weight must be deducted from the rated lifting capacity to determine the net load.

Lifting capacities are based on boom sections locked by remote control in appropriate position as per operator's hand book.

Consult crane manual to determine weight reduction for load handling devices and boom attachments.

Operate crane strictly in accordance with operator's manual.

*: ± 10° over rear
 *): represents test load over rear
 B: Outrigger base 26'3"

Load capacities above bold line are based on structural strength, and tipping must not be relied upon as a limitation of lifting capacity. Rated loads must not be exceeded.

Hook elevation diagram

Main boom

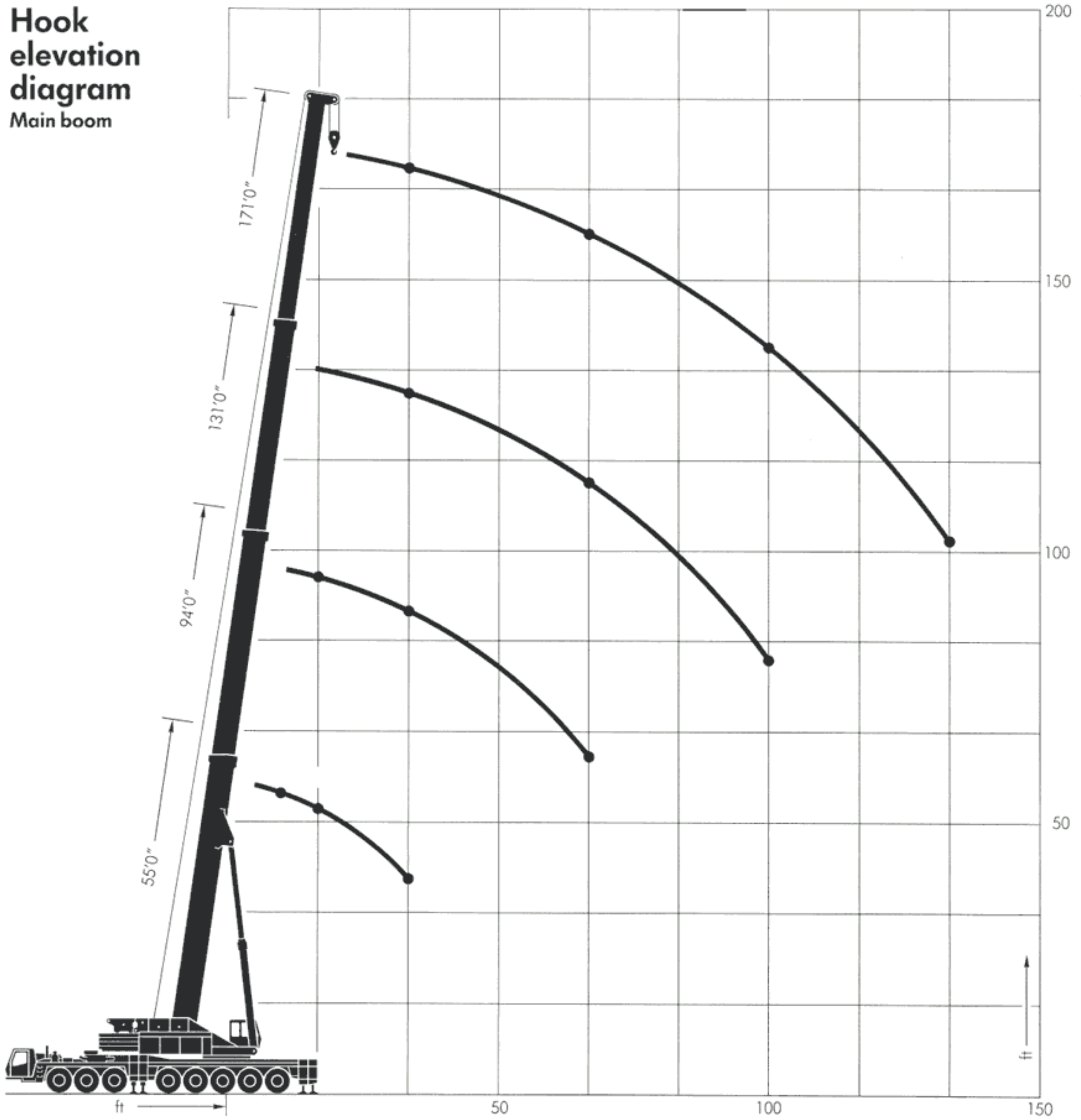

Hooks

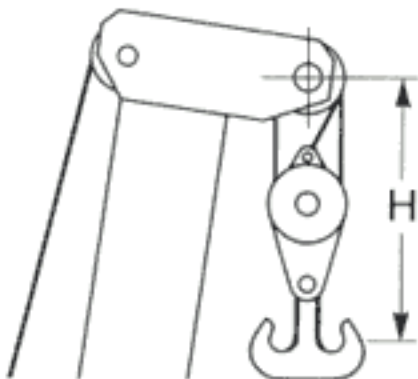

Capacity	ton	265	145	90	35
Sheaves		12	6	4	1
Distance H	ft	9'6"	8'2"	7'7"	6'10"
Weight	ton	3.3	1.9	1.2	0.7

Lifting capacities in 1000 lbs on outriggers

360° Boom extension

0° Off-set angle

Counterweight 132,280 lbs

Radius (ft)	Boom length 164 ft				
	Jib length (ft)				
	40'0"	53'0"	66'0"	92'0"	118'0"
40	56.2				
45	56.2	47.4	39.6		
50	56.1	47.4	39.6	27.5	
55	54.3	46.4	39.6	27.5	
60	51.5	44.5	39.4	27.5	19.8
65	49.0	42.3	37.8	27.5	19.8
70	46.8	40.4	36.0	27.5	19.8
75	44.6	38.6	34.3	27.1	19.8
80	42.5	36.7	32.7	26.3	19.7
85	40.6	34.9	31.3	25.0	19.4
90	38.8	33.4	29.8	23.8	18.6
95	37.0	32.0	28.5	22.7	17.8
100	35.4	30.7	27.4	21.7	17.2
105	33.7	29.5	26.2	20.7	16.5
110	32.2	28.3	25.0	19.8	15.6
115	30.7	27.3	24.0	19.0	15.0
120	29.1	26.2	23.0	18.2	14.5
125	27.7	25.0	22.2	17.5	13.8
130	26.5	24.0	21.1	16.9	13.1
135	25.0	22.9	20.4	16.1	12.6
140	23.6	21.8	19.7	15.3	12.1
145	22.3	20.8	19.0	14.7	11.6
150	20.9	20.1	18.2	14.2	10.9
155	19.2	19.3	17.5	13.5	10.3
160	17.4	18.2	16.7	12.9	9.9
165	15.7	16.6	15.9	12.4	9.6
170	14.0	15.1	15.2	11.9	9.1
175	12.7	13.6	14.0	11.3	8.5
180		12.1	12.7	10.8	8.1
185		10.7	11.5	10.4	7.8
190		9.7	10.2	10.1	7.5
195			9.0	9.8	7.1
200				9.2	6.8
205				8.5	6.4
210				7.7	5.9

20° Off-set angle

Counterweight 132,280 lbs

Radius (ft)	Boom length 164 ft				
	Jib length (ft)				
	40'0"	53'0"	66'0"	92'0"	118'0"
40					
45					
50					
55	39.0				
60	37.9	35.9			
65	36.7	34.5			
70	35.5	33.3	29.4		
75	34.4	32.3	28.5		
80	33.4	31.4	27.6	20.3	
85	32.4	30.4	26.9	19.6	
90	31.4	29.7	25.9	19.0	
95	30.5	28.8	25.2	18.4	13.6
100	29.7	27.6	24.7	17.8	13.1
105	29.1	26.6	24.0	17.1	12.7
110	28.4	25.1	23.0	16.6	12.2
115	27.7	24.3	22.2	16.0	11.6
120	27.1	23.6	21.4	15.5	11.1
125	26.6	22.6	20.4	15.1	10.7
130	26.1	22.1	19.7	14.6	10.4
135	25.6	21.4	19.1	14.1	9.9
140	25.2	20.6	18.4	13.7	9.5
145	24.6	19.9	17.7	13.4	9.2
150	23.0	19.3	17.1	13.0	8.8
155	21.0	18.4	16.4	12.7	8.5
160	19.1	17.6	15.9	12.3	8.2
165	17.3	16.8	15.5	11.7	7.8
170	15.6	15.9	15.0	11.1	7.5
175	13.9	15.1	14.5	10.7	7.2
180		13.8	14.0	10.3	6.8
185		12.2	13.3	10.0	6.5
190		10.8	12.1	9.7	6.1
195			10.8	9.3	5.8
200				8.9	5.5
205				8.4	5.1
210				8.1	4.8

Hook elevation diagram

Boom extension

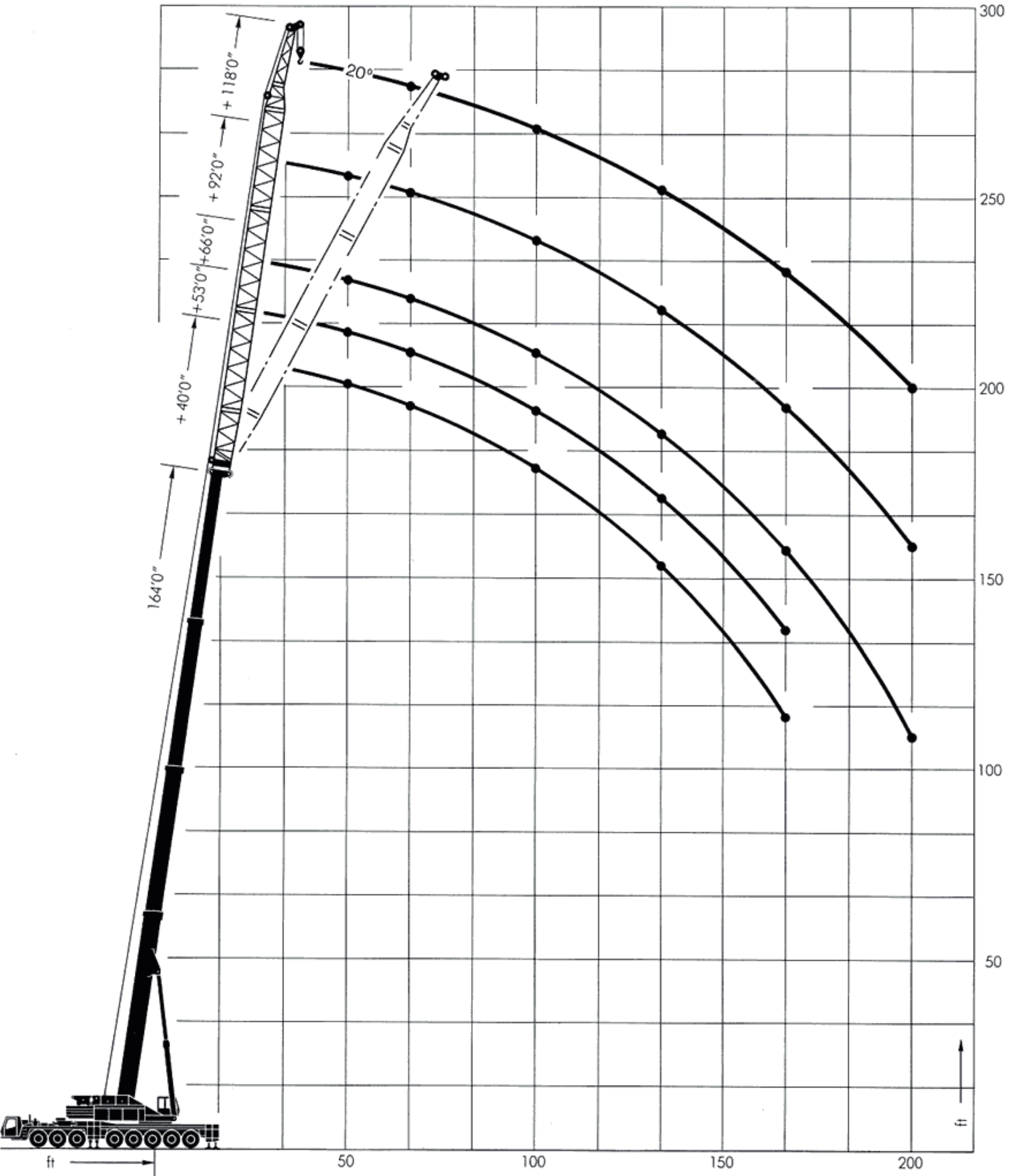

Lifting capacities in 1000 lbs on outriggers

360° Power luffing jib

Counterweight 132.280 lbs

Radius (ft)	Jib length (ft)													
	53*	66*	79*	92*	105	118	131	144	158	171	184	197	210	
Boom length 91'0" + 5'0" = 96'0"	40	135.0												
	45	125.0												
	50	107.2												
	55		114.1											
	60		101.6	104.4	94.3									
			87.2	96.6	93.4	82.0								
	65		76.3	85.1	88.5	82.0								
	70			76.1	80.0	79.9	70.3							
	75			68.3	72.2	74.9	70.3	59.7	50.4					
	80				65.3	68.2	69.1	59.7	50.4	42.5				
	85				60.0	62.5	64.2	59.7	50.4	42.5				
	90				55.0	57.7	59.5	58.9	50.4	42.5	36.3			
	95					53.6	55.2	56.2	50.4	42.5	36.3	31.7	26.0	
	100						51.3	52.5	50.4	42.5	36.3	31.7	26.0	22.0
	105						47.6	49.1	50.4	42.5	36.3	31.7	26.0	22.0
	110						44.5	46.1	46.9	42.5	36.3	31.7	26.0	22.0
	115							43.4	43.7	42.4	36.3	31.7	26.0	22.0
	120							40.8	40.9	41.3	36.3	31.7	26.0	22.0
	125								38.4	38.8	36.3	31.7	26.0	22.0
	130								36.2	36.5	36.3	31.7	26.0	22.0
135								34.1	34.4	34.7	31.7	26.0	22.0	
140									32.4	32.6	31.4	26.0	22.0	
145										30.6	30.6	26.0	22.0	
150										28.9	28.9	26.0	22.0	
155										27.5	27.5	26.0	22.0	
160											26.2	25.6	22.0	
165												24.9	22.0	
170												23.7	22.0	
175													22.7	
180													21.6	
185														
190														
Boom length 128'0" + 5'0" = 133'0"	50	75.5												
	55	72.4												
	60	69.7	69.0											
	65	68.1	66.9	60.9										
	70		64.2	60.2										
			62.1	58.4	53.1									
	75			56.4	52.7	46.0	39.9							
	80			54.8	51.9	46.0	39.9	34.6						
	85			53.6	50.5	46.0	39.9	34.6						
	90				49.3	46.0	39.9	34.6	29.9					
	95				48.3	45.3	39.9	34.6	29.9	25.7	22.2			
	100					44.3	39.9	34.6	29.9	25.7	22.2	19.1		
	105					43.6	39.9	34.6	29.9	25.7	22.2	19.1	16.0	
	110					42.9	39.7	34.6	29.9	25.7	22.2	19.1	16.0	
	115						39.2	34.6	29.9	25.7	22.2	19.1	16.0	13.6
	120							34.6	29.9	25.7	22.2	19.1	16.0	13.6
	125							34.6	29.9	25.7	22.2	19.1	16.0	13.6
	130							34.4	29.9	25.7	22.2	19.1	16.0	13.6
	135								29.9	25.7	22.2	19.1	16.0	13.6
	140								29.9	25.7	22.2	19.1	16.0	13.6
145								29.9	25.7	22.2	19.1	16.0	13.6	
150									25.7	22.2	19.1	16.0	13.6	
155									25.7	22.2	19.1	16.0	13.6	
160										22.2	19.1	16.0	13.6	
165											19.1	16.0	13.6	
170												16.0	13.6	
175													19.1	
180														
185														
190														
195														
200														

Lifting capacities in 1000 lbs on outriggers

360° Power luffing jib

Counterweight 132.280 lbs

Radius (ft)	Jib length (ft)												
	53*	66*	79	92	105	118	131	144	158	171	184	197	210
60	41.8												
65	41.8												
70	38.3	35.9	30.4										
75		35.9	30.4	26.6									
80		35.3	30.4	26.6	22.9								
85		33.0	30.4	26.6	22.9	19.4							
90			30.4	26.6	22.9	19.4							
95				26.6	22.9	19.4	16.0						
100				26.6	22.9	19.4	16.0	13.6	11.2				
105				26.6	22.9	19.4	16.0	13.6	11.2	9.2			
110					22.9	19.4	16.0	13.6	11.2	9.2			
115					22.9	19.4	16.0	13.6	11.2	9.2	7.5		
120						19.4	16.0	13.6	11.2	9.2	7.5	6.1	
125						19.4	16.0	13.6	11.2	9.2	7.5	6.1	5.0
130						19.4	16.0	13.6	11.2	9.2	7.5	6.1	5.0
135							16.0	13.6	11.2	9.2	7.5	6.1	5.0
140								13.6	11.2	9.2	7.5	6.1	5.0
145								13.6	11.2	9.2	7.5	6.1	5.0
150								13.6	11.2	9.2	7.5	6.1	5.0
155									11.2	9.2	7.5	6.1	5.0
160									11.2	9.2	7.5	6.1	5.0
165										9.2	7.5	6.1	5.0
170										9.2	7.5	6.1	5.0
175										9.2	7.5	6.1	5.0
180											7.5	6.1	5.0
185												6.1	5.0
190												6.1	5.0
195													5.0
200													5.0

*: With compensation weights

Hook elevation diagram

Power luffing jib

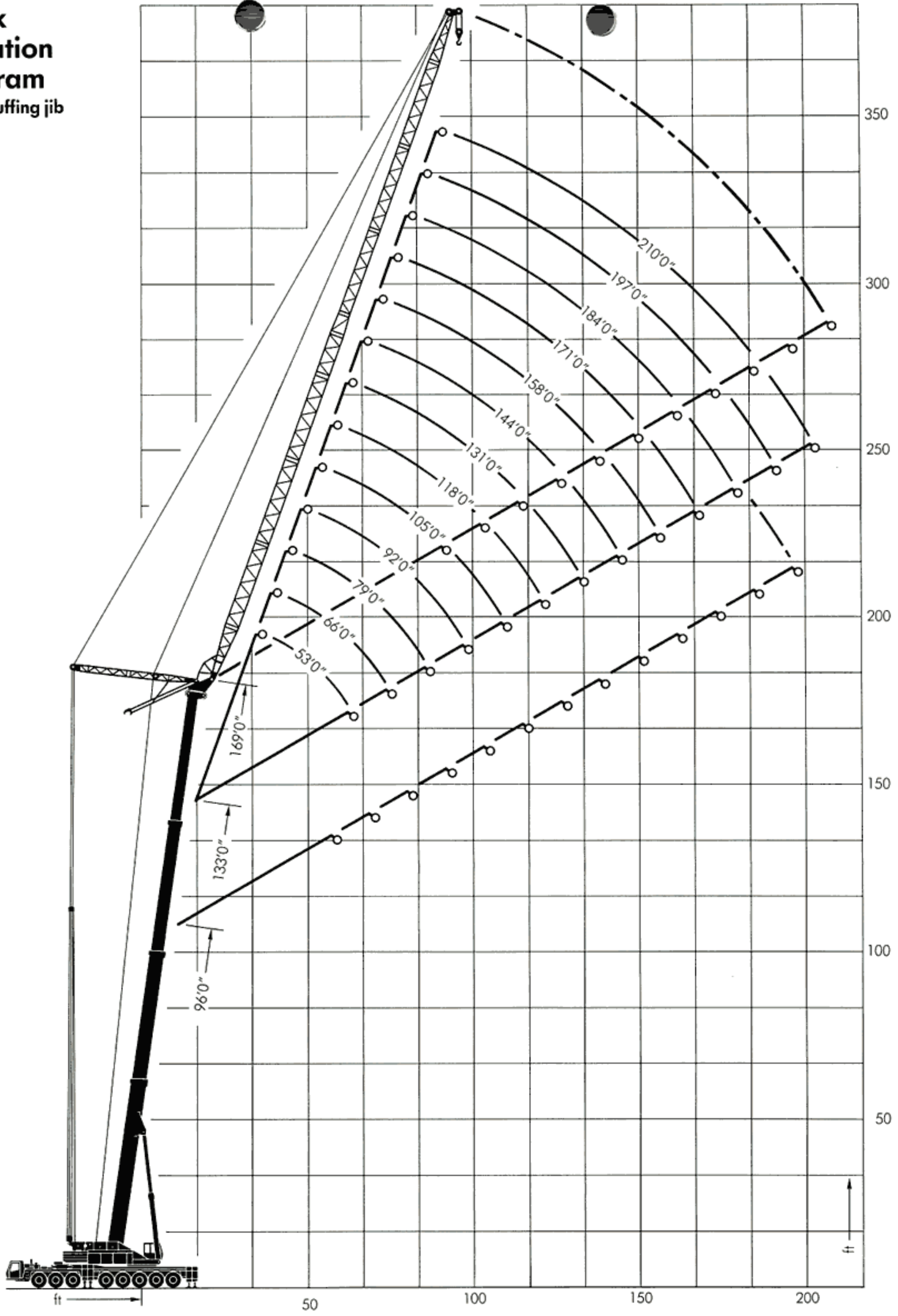

Jibs

Boom extension

In sections of 26'0" from 40'0" to 118'0", welded lattice-type construction, 20° off-set

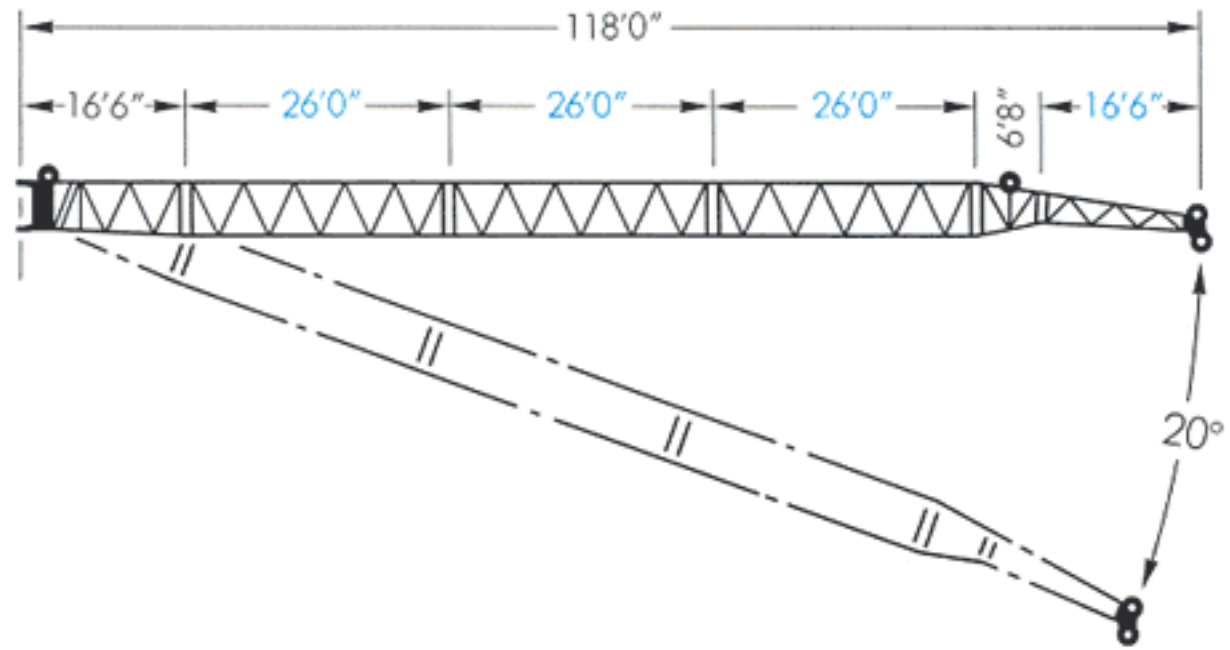

Power luffing jib

In sections of 26'0" from 53'0" to 210'0", welded lattice-type construction, including luffing jib adaptor, A-frame, back-stop, pendant ropes, luffing block and anemometer. Luffing jib operated by auxiliary hoist

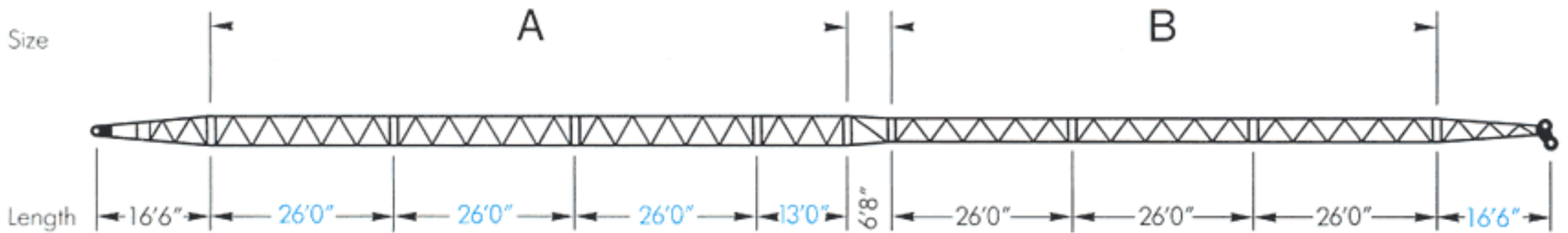
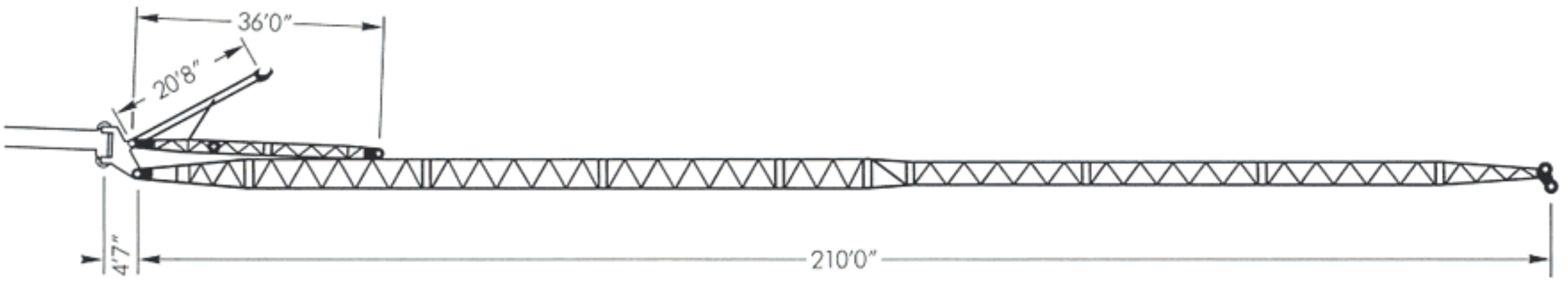



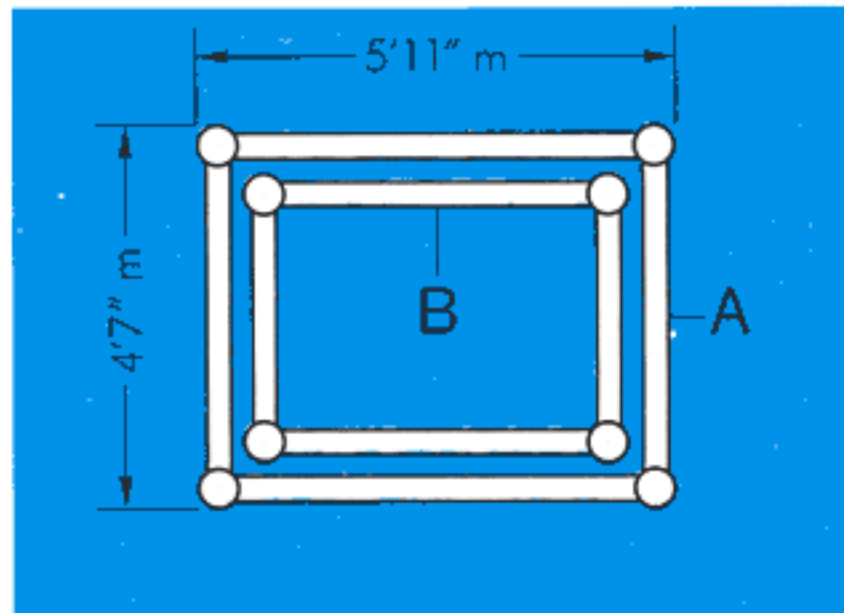





Blue figures: elements alternatively used for either lattice boom extension or luffing jib configuration.



Krupp Hydraulic Mobile Cranes

Product Range

Truck Cranes		Max. lifting capacity	Max. hook height
100 GMT		120 ton	220 ft*
180 GMT		250 ton	320 ft*
250 GMT		365 ton	345 ft*
350 GMT		450 ton	365 ft*
500 GMT		600 ton	430 ft*
All-Terrain Cranes			
25 GMT-AT		25 ton	122 ft
35 GMT-AT		35 ton	129 ft
70 GMT-AT		80 ton	178 ft
140 GMT-AT		165 ton	296 ft*

* incl. power luffing jib

Krupp Industries Inc.
1370 Washington Pike
Bridgeville, Pa. 15017/USA

Telephone (412) 221-7041
Telex 6818083
Telefax (412) 221-7684

Krupp Canada Inc.
98 Columbus Street
Pointe Claire, Que. H9R 4K4/Canada

Telephone (514) 694-4740
Telex 05-822881
Telefax (514) 694-5280

Subject to technical modifications without notice