

STANDARD EQUIPMENT

- 80 Gallon Sprinkler System
- Two-Post ROPS Canopy
- Rear Fenders
- Positive Neutral Start
- Hydraulic Power Steering
- Hydraulic Drum Rear Towing Brakes
- Mechanical Parking Brake
- Gear Motor Final Drive
- P205 75R14 4-Ply Radials
- Automotive-Style Tow Hitch. Includes Surge Brakes, Towing Lights and Wiring Harness
- All Polyethylene Brush, all Steel Wire Brush, or 1/2 and 1/2
- Choice of 2" or 2-5/16" ball hitch, or 3" pintle hitches
- Greasable Front Wheel Spindle
- Omaha Orange Paint
- Steel Broom Core
- Front Debris Deflector
- 9 Gallon Fuel Tank w/Mechanical Gauge
- Cushioned Seat with 2" Retractable Seat Belt & Arm Rests
- Reverse Alarm
- Electric Hour Meter
- Hydraulic Sight Gauge
- Warning Light Package, Engine Oil Pressure, Water Temperature and Alternator
- Engine Protection System
- Hub-Engaged Warning System

TOW PACKAGE

- No jack
- One man operation
- All wheels on the ground during towing
- Minimal tongue weight
- Surge brakes
- Towing lights
- Turn signals

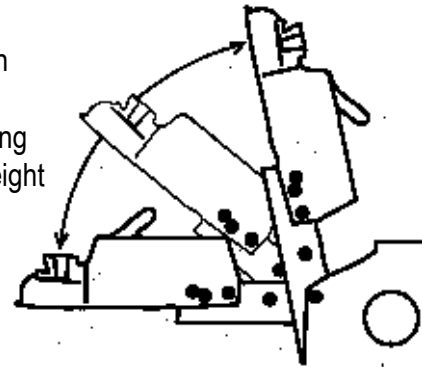

OPTIONS

- Variable Broom Speed
- Dual Broom Drive Motors
- Special Paint Colors
- Vista Cab (factory installed only)
- Heater
- Defroster
- Strobe Light
- Rotating Beacon
- Work Lights
- Emergency Working and Turn Signal Lights

SPECIFICATIONS

Engine	Kubota V1505 diesel, 37 HP
Broom Size	6-3/8" I.D. x 24" O.D.
Broom Angle	40° (each way)
Steering	45° (each way)
Speed	0 to 7.5 mph
Machine Weight	6HC 3,000#
Machine Weight	8HC 3,100#
Transport Width, Fully Angled	6HC 6'9"
Transport Width, Fully Angled	8HC 7'10"
Transport Length, Hitch Down	14'

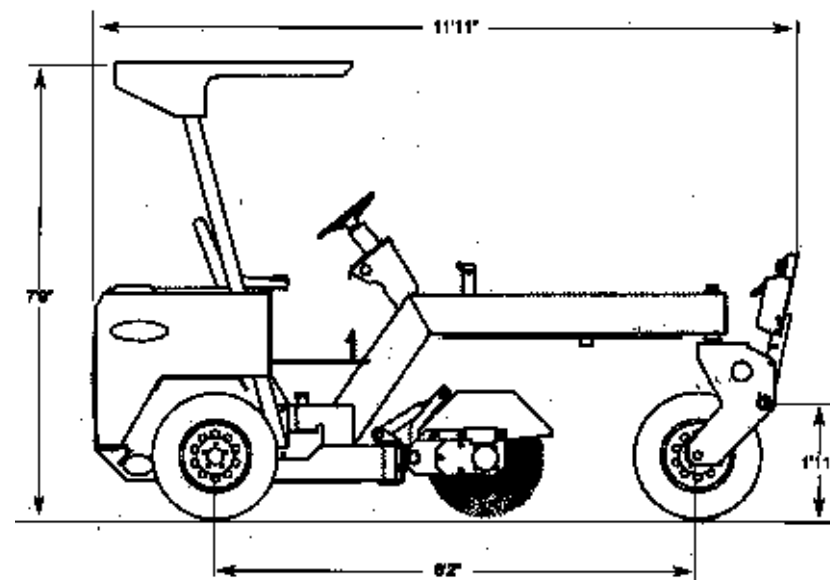

All specifications are in accordance with SAE standards or recommended practices where applicable. Under our policy of improvement, Mobile Products, Inc. reserves the right to modify specifications at any time without prior notice or obligation. Units shown may include optional equipment. Lay-Mor equipment is manufactured by Mobile Products, Inc.



Model 6HC/8HC Three Wheel Sweeper

- Broom down pressure easily adjusted to match job
- Translucent water tanks for quick view of water level
- Swing up hood for easy engine access
- Certified roll-over protection structure
- Advanced hitch/towing package
- Available with 6' or 8' brush
- Available with open canopy (shown) or climate controlled Vista cab



DESIGNED TO INCREASE RENTAL UPTIME

Proven and accepted as #1 leader in the rental sweeping industry, the Lay-Mor Model 6HC/8HC is operator friendly and is easily transported from job to job. There is no need to raise the front wheel off the ground for towing purposes and the tongue can pivot right or left and up and down for faster and easier hook-up. More easily accessible maintenance allows for servicing the unit quicker and simpler than competitive products.



Lay-Mor 6HC/8HC Three Wheel Sweeper

Primary Features
and Benefits

Hitch/Towing
Package

*"#1 in Operator Choice, Features,
and Rentability"*

A whole new approach in towing package design. We've eliminated the jack so that hitching up is an easy one-man operation. Our advanced design assures minimum tongue weight and more evenly distributed load due to three-wheels-on-ground towing, even with fully loaded sprinkler system. Hitch mount comes equipped with surge brakes, towing lights and turn signals.

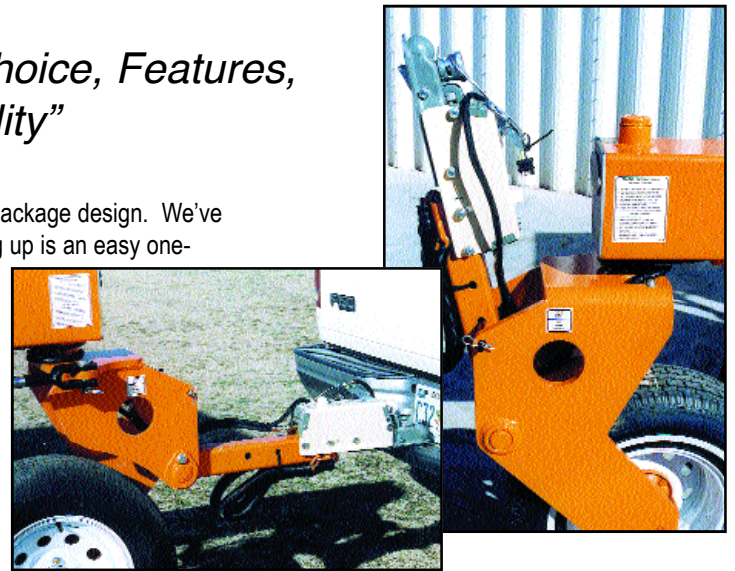

A sturdy protective cover has been added to prevent hub damage. Also, our new front fork pivot bearings have more bearing area for longer life and less wear.



Broom

Lay-Mor's exclusive down pressure control is designed to maintain optimum broom-to-ground contact. This feature also ensures maximum brush life.

A full length debris shield has been added to minimize dust and debris. The standard dust control sprinkler system includes spray nozzles integrated into the broom cover for a cleaner design, more effective water distribution and, by eliminating the need for a spray bar, fewer parts to maintain.



Large skid plates installed on the broom mounting assure longer life in heavy wear applications. We've gone to a single, larger field-proven long life broom drive motor - a design used for years in our four wheel sweepers.

Engine Access

Our new swing-up hood offers quicker engine component service with less hassle. Easy to service air cleaner has secondary filter for cleaner intake air and longer engine life.

Two 40 gallon translucent tanks provide a quick view of water level and have a lower profile look with long-lasting reservoir support for durability.

Water Tanks

Operator Comfort

Operator area features a certified roll over protection structure, easy-to-use entrance steps and a new style, comfortable, adjustable seat with arm rests. Automotive-style foot pedal provides easy acceleration and dynamic braking. A convenient parking brake with recessed handle is included.



NEW VISTA CAB OPTION -

Enhances operator comfort and visibility. Optional factory installed cab with pressurizer reduces exposure to dust and extreme weather conditions. Includes tinted safety glass windows, 2-speed electric windshield wiper, right and lefthand doors and optional heater with 2-speed blower, defroster fan, and air conditioner.



Wide, no-slip honeycomb surface provides less operator fatigue and improved operational comfort.



Large, well placed tie down points allow quick and efficient tie down when hauling and prevents damage due to improperly placed restraints.

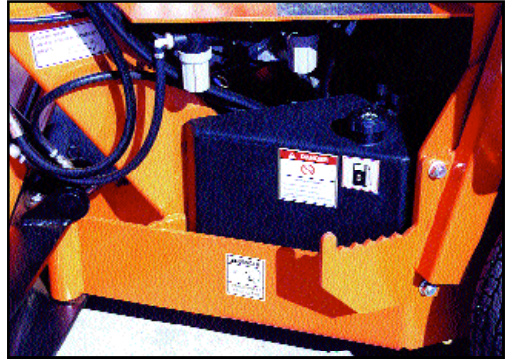

No more fuel sight gauges and hard to clean fuel tanks. The polyethylene fuel tank eliminates rust contamination and is easily removable should fuel become contaminated. The fuel tank features a top mounted mechanical gauge for quick, easy fuel checks.



Protect your investment from accidental operator error during transport by equipping your sweeper with our exclusive optional Hub-Engaged Warning System.

During rear wheel movement with engine off, a sensor detects when wheel drive motors have not been disengaged, automatically activating a horn and blinking front mounted warning light (shown at left).

A reversed warning decal is also prominently displayed in front of the dash panel, easily recognized by glancing at the operator's rear view mirror.

Cab Option

Automotive style foot
pedal

Tie Downs

Removable, Easy
Clean Fuel Tank

Exclusive
Hub-Engaged
Warning System

401 Capacity Drive
Longview, TX 75604
903-759-0610 • Fax: 903-759-3209
www.lay-mor.com