

LEGUAN[®]

Access platforms

The pioneer - I25

All in one - I35

Solid and stable - I60



Leguan access platforms are designed for heavy duty professional and rental use. The unique Leguan concept provides durability, strength, speed and user friendliness.







The fastest spider in its class

- Drive speed up to 4.5 km/h
- Simultaneous operation for all boom movements
- The platform can be raised and lowered diagonally
- Quick and precise automatic leveling also on uneven surface
- Quick release system for basket



All-rounder in all terrain

- Versatile driving features
- Four wheel drive instead of tracks, enables faster driving speed
- Over dimensioned (height 570 mm) off-road tracks provide high ground clearance and excellent all terrain capabilities
- Jockey wheel for delicate surfaces such as grass, building foundations and paving
- Electric motor and tyre cloth bags for indoor use
- Robust steel bottom plate protection



Transportation made easy

- Light weight special trailers
- Total towing weight under 2000kg (125, 135)
- Total towing weight under 3000kg (160)
- Leguan can be operated directly from the trailer
- Quick loading, unloading and fastening



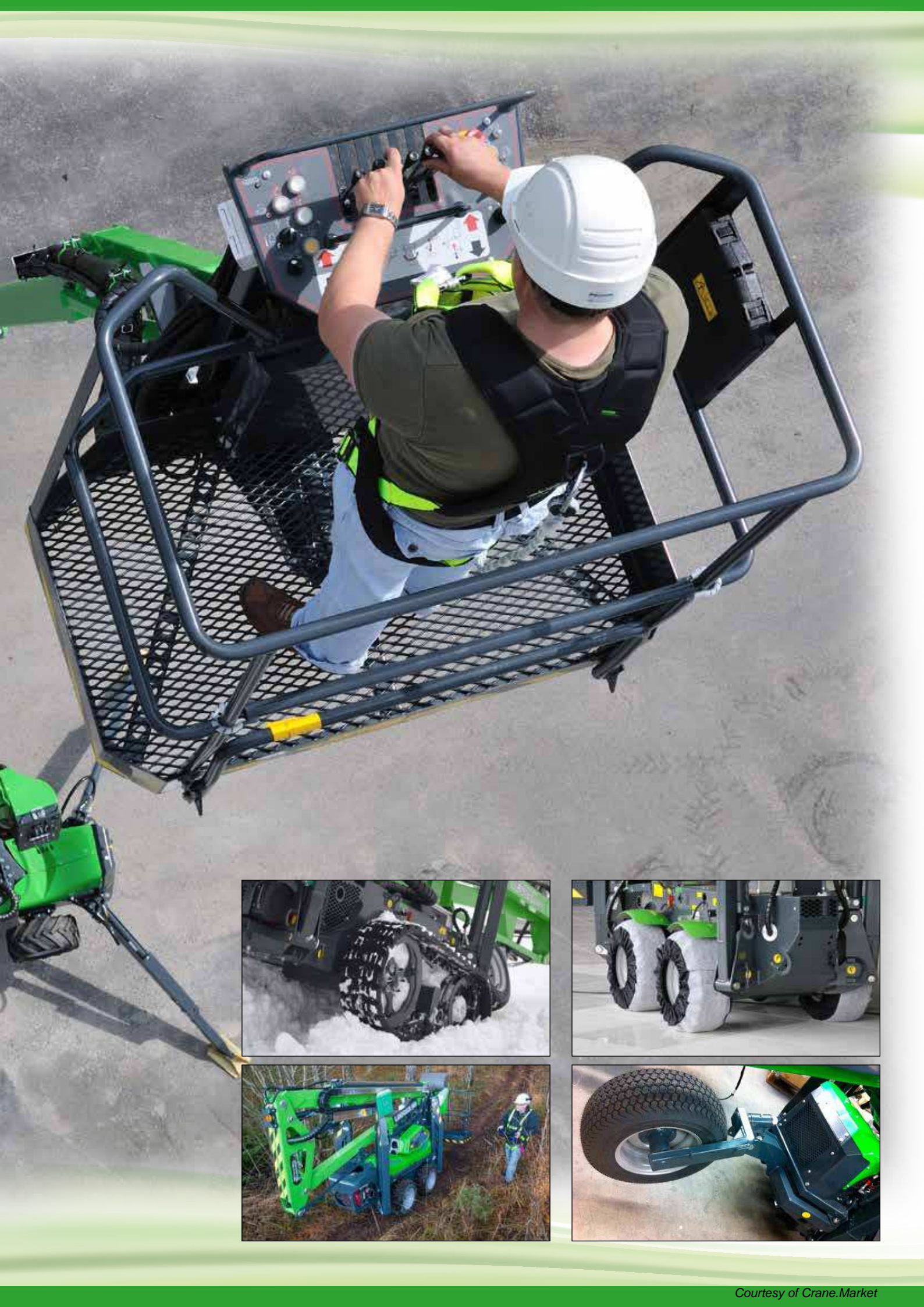



Leguan - as versatile as its users

- **Rental companies**
- **Contractors**
- **Painters**
- **Plasterers**
- **Electricians**
- **Landscapers**
- **Tree trimmers**
- **Municipalities**
- **Industrial maintenance**
- **Property maintenance**
- **House improvement**
- **Military**
- **Etc.**

125

The pioneer

	LEGUAN 125
SWL	200 kg / 2 persons
Max. working height	11.30 m (200 kg), 12.50 m (<135 kg)
Max. platform height	9.30 m (200 kg), 10.50 m (<135 kg)
Max. outreach	5.10 m (200 kg), 6.50 m (<135 kg)
Total length	5.16 m
Platform dimensions W x L	1.20 m x 0.70 m
Slewing	360°
Gradeability	35% (20°)
Outrigger spread working	2.94 m x 2.89 m
Max. slope for outriggers	22% (13°)
Weight with tracks / tyres	1650 kg / 1500 kg
Power source	Honda 13 hp petrol 230 V / 110 V
Drive system: hydraulic	4WD Tracks
Drive speed max., tracks / tyres	3.5 km/h / 4.1 km/h

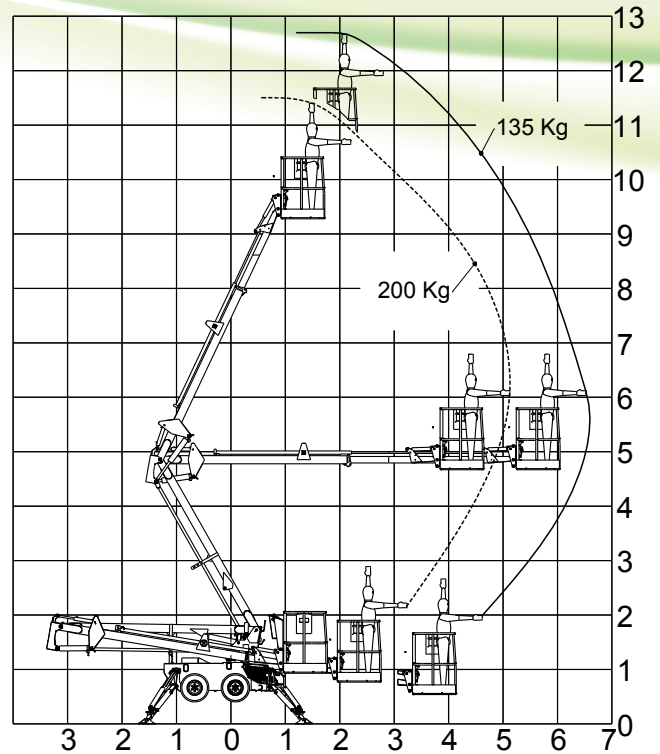

- Simple and economical
- Direct hydraulic controls
- Active weight control
- Pressure-sensing outrigger control
- Two boom design
- Telescopic boom
- Low transport height, 1800 mm

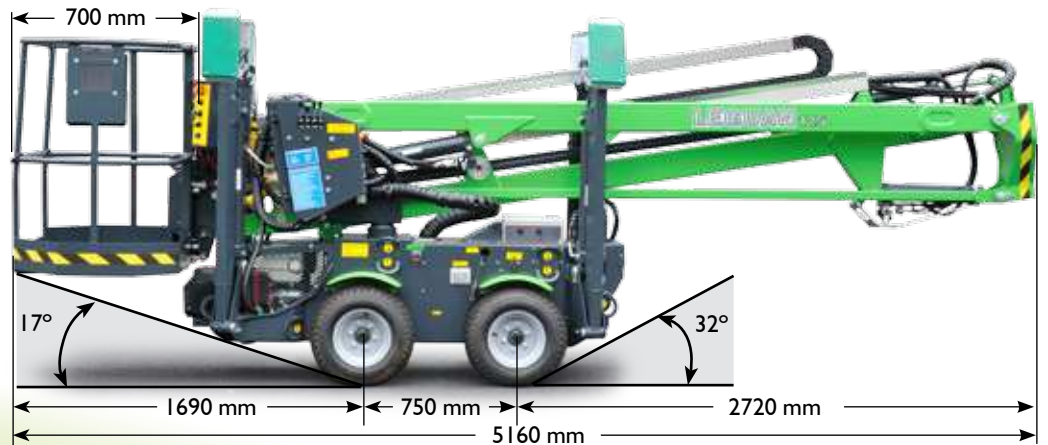
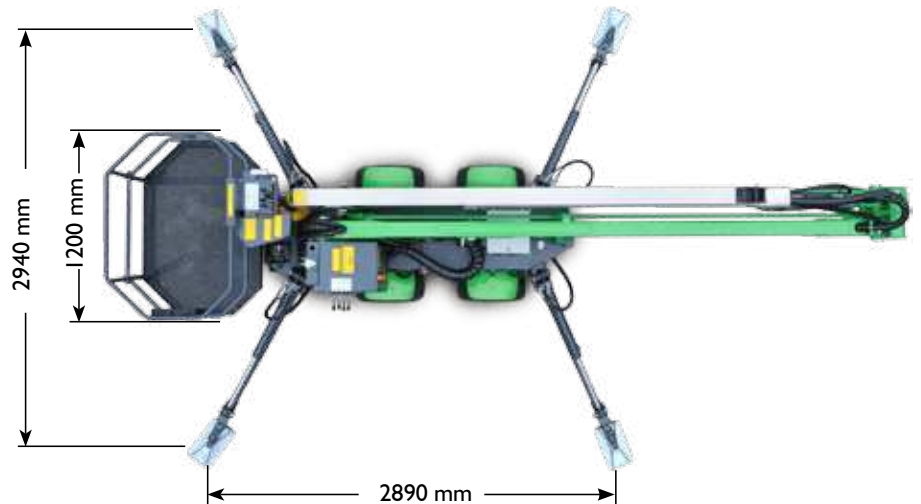

135 All in one

	LEGUAN 135
SWL	230 kg / 2 persons
Max. working height	12.20 m (230 kg), 13.20 m (< 140 kg)
Max. platform height	10.20 m (230 kg), 11.20 m (< 140 kg)
Max. outreach	5.80 m (230 kg), 6.80 m (< 140 kg)
Transport length	4.50 m
Transport height	2.07 m
Transport width	1.33 m / 1.00 m (without basket)
Platform dimensions W x L	1.33 m x 0.75 m
Rotation of basket	90° (± 45°)
Slewing	360°
Gradeability	35 - 40%
Outrigger spread working	3.13 m x 3.05 m
Max. slope for outriggers	20% / 11°
Ground clearance	150 mm (tyres) 250 mm (tracks)
Weight with tracks / tyres	1850 kg / 1700 kg
Power source	Honda iGX 390 13 hp petrol 230 V / 110 V
Drive system: hydraulic	4WD Tracks
Drive speed max., tracks / tyres	3.0 km/h / 3.5 km/h

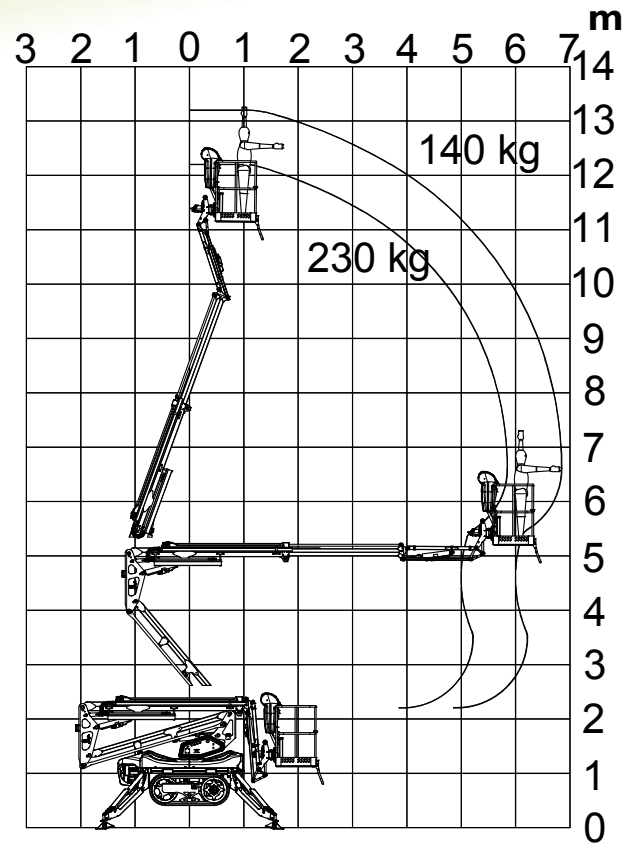

- Automatic leveling
- High basket capacity, 230 kg
- New Honda iGX390 with automatic throttle and choke (fuel consumption -15% compared to a similar conventional engine)
- Remote controlled (Scanreco)
- Safety control (IFM)
- Digital weight control
- Negative jib boom (120° boom angle)
- Four speed drive
- Skid steer and easy drive mode
- Quick release system for basket
- Forklift holes through the machine frame
- Electrically operated proportional controls
- Compact and light weight

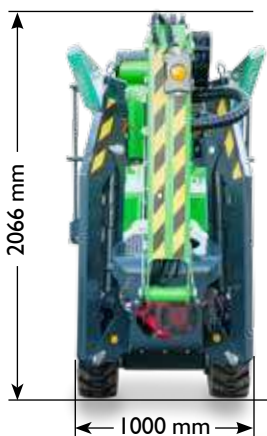
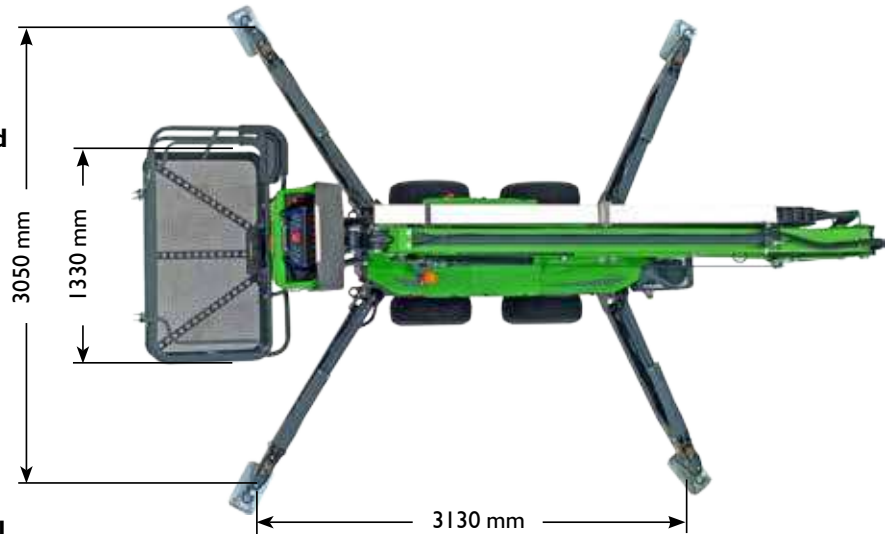

160 Solid and stable

	LEGUAN 160
SWL for the entire working area	200 kg / 2 persons
Max. working height	15.90 m
Max. platform height	13.90 m
Max. outreach	6.70 m
Transport length	4.94 m
Platform dimensions W x L	1.30 x 0.75 m
Rotation of basket	90° (±45°)
Slewing	360°
Gradeability	35% (20°)
Outrigger spread working	3.29 x 3.26 m
Max. slope for outriggers	22% (13°)
Weight with tracks / tyres	2400 kg / 2100 kg
Power source	Kubota 14 hp diesel
	230 V / 110 V
Drive system: hydraulic	4WD
	Tracks
Drive speed max., tracks / tyres	3.5 km/h / 4.5 km/h

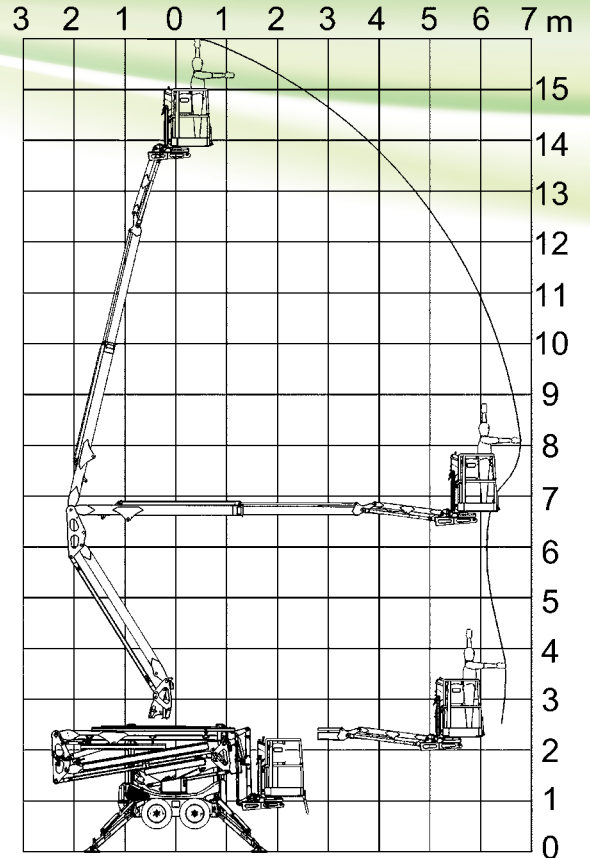

- Robust three boom design
- Direct hydraulic controls
- Active weight control
- Pressure-sensing outrigger control
- Telescopic boom
- High platform capacity over whole working area
- Excellent maneuverability next to a wall, straight vertical lifting up to 9 m

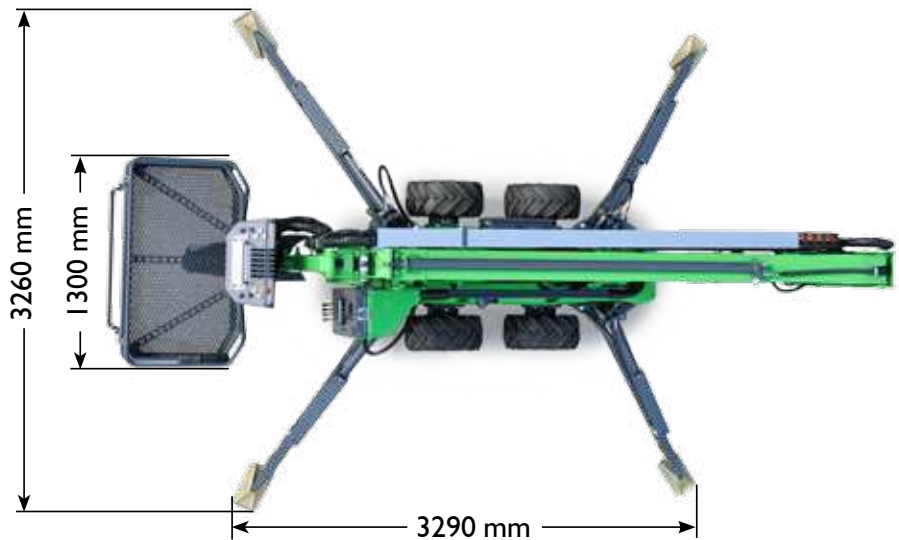

Options



- Grass or tractor type tyres
- Non-marking white tyres
- Puncture proof tyres
- Tyre cloth bags



- All terrain rubber tracks instead of wheels
- Non-marking white tracks



- Jockey wheel limits the "skid steer effect" and minimizes the marks on grass or other delicate surfaces. (Not available I35)



- Lower controls enable the lift to be operated from ground



- 230 V (110 V) electric motor for lifting and driving



- Two outlets 230 V (110 V) at platform provide electricity for power tools



- Hose to platform (compressed air / water)
- Enables use of pressure washer or compressed air



- Plastic pads (4 pcs) on outrigger plates protect the surface from outrigger marks



- Extra large (40 x 30 cm) outrigger plates for soft and giving grounds such as sand, mud, snow, etc.



- Booster points provide easy access to jump-start the machine



- Engine heater for cold temperatures



- Led flash lights (5 pcs) with on / off switch



- Electric choke for the engine on a platform
- Automatic choke on I35



- Foot pedal on platform "Dead-man-switch"



- Each lift offered with model specific trailer, which guarantees safe and minimum weight transportation

Please visit www.leguanlifts.com for more options



Member of Avant Group

Leguan Lifts has always been a pioneer in the market. In 1994, Leguan Lifts was the first manufacturer to introduce self propelled compact access platforms equipped with outriggers – commonly called as spider lifts. Today, Leguan belongs to Avant Group and is known for being the specialist in manufacturing spider lifts under 20 meters.

From the very beginning, Leguan has been co-operating with Avant Tecno Oy. Leguan has capitalised on Avant Tecno's expertise in manufacturing compact wheel loaders with hydrostatic transmission. The Leguan concept was created by combining the knowledge of lifts and wheel loaders. As with all Avant Group products, Leguan Lifts share the same core competencies of innovative product development and unique design combined with high standards on spare parts availability.

In the design of the latest 135 model, Leguan has yet again proven to be the pioneer. We have utilized both our 25 years of experience on spider lifts, as well as the know-how brought by more than 40,000 Avant loaders.



Member of
AVANT[®]
Group



LEGUAN[®]

Ylötie 10, FI-33470 Ylöjärvi, Finland
Tel. +358 3 347 6400 Fax +358 3 347 6446
leguan@avanttecno.com



Made in Finland



Leguan has a policy of continuing improvement, and retains the right to change specifications without notice. © 2015 LEGUAN Lifts Oy. All rights reserved.

www.leguanlifts.com

Courtesy of Crane.Market