

Mobile Harbour Crane

LHM 800



LIEBHERR

Courtesy of Crane.Market

Main dimensions

Heavy duty operation LHM 800

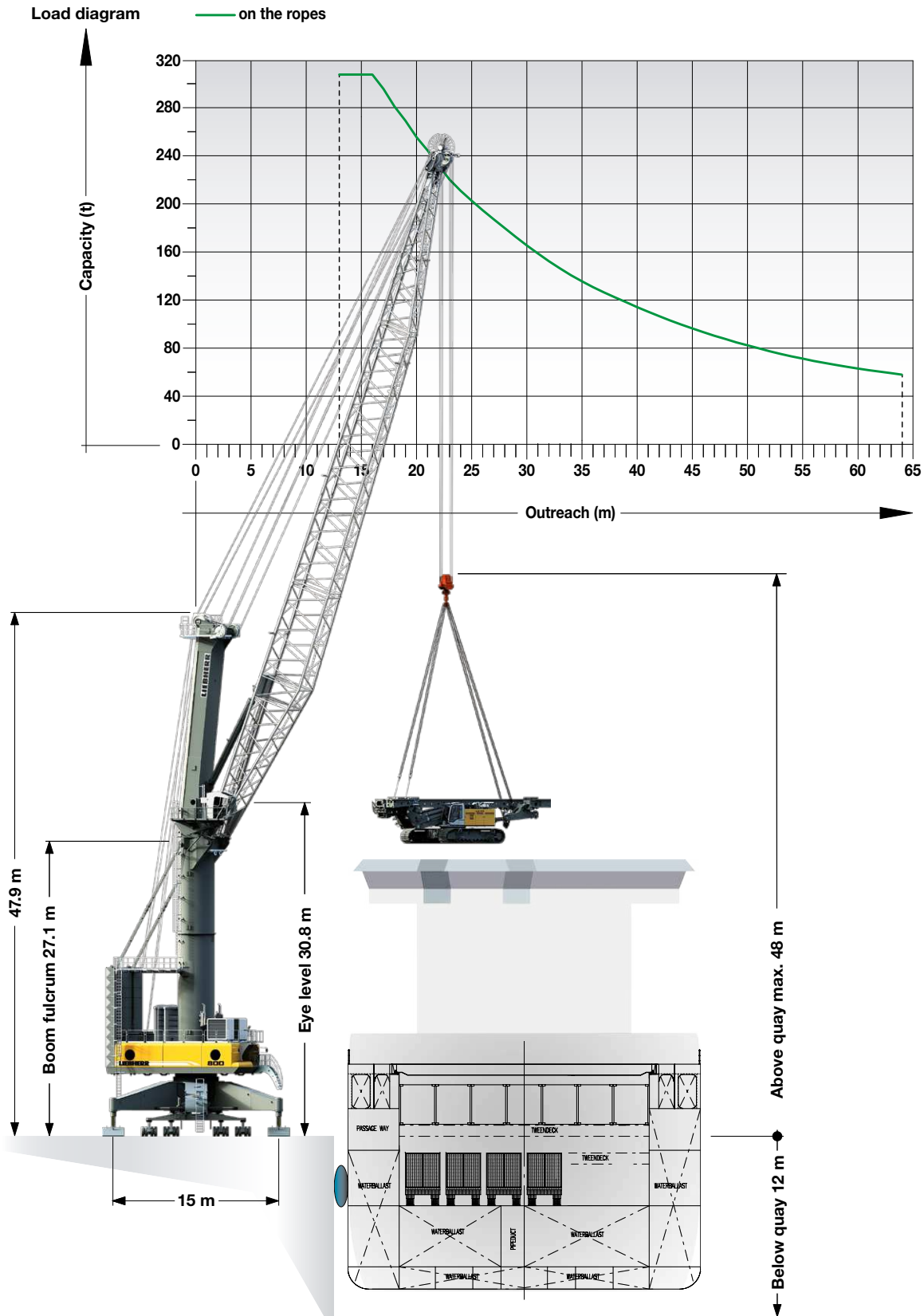

Lifting capacities

Heavy duty operation LHM 800

Maximum crane capacity 308 t

Outreach (m)	Hook operation on the ropes
	Heavy lift (t)
13	308.0
14	308.0
15	308.0
16	308.0
18	281.4
20	255.9
22	232.4
24	211.1
26	194.9
28	180.0
30	165.6
32	152.5
34	140.8
36	130.8
38	122.2
40	114.2
42	106.6
44	99.6
46	93.3
48	87.6
50	82.3
52	77.4
56	69.2
58	65.9
60	62.9
62	60.3
64	57.9

Project cargo & heavy duty up to 308 tonnes

Safety and precision are the most important criteria when lifting heavy goods.

- The hydrostatic drive concept in connection with closed hydraulic circuits guarantees immediate system reaction times for rapid and safe working cycles.
- The X-shaped propping arrangement forms the basis of a unique stress flow-system absorbing all static and dynamic demands resulting from travelling and operation of the crane.
- Stresses and strains occurring during heavy lift operation are thereby transmitted via the shortest route through the centre of the chassis onto the outriggers and further to the ground.
- Torsion strain in the undercarriage is reduced to a minimum.
- Lifetime of the slewing bearing and all supporting parts enhances.
- The luffing cylinder also uses a closed hydraulic circuit, assuring accuracy without vibration.
- Sycratronic® allows two Liebherr mobile harbour cranes to be operated simultaneously by one crane driver for improved speed, capacity and safety.

Main dimensions

Hook & container operation LHM 800

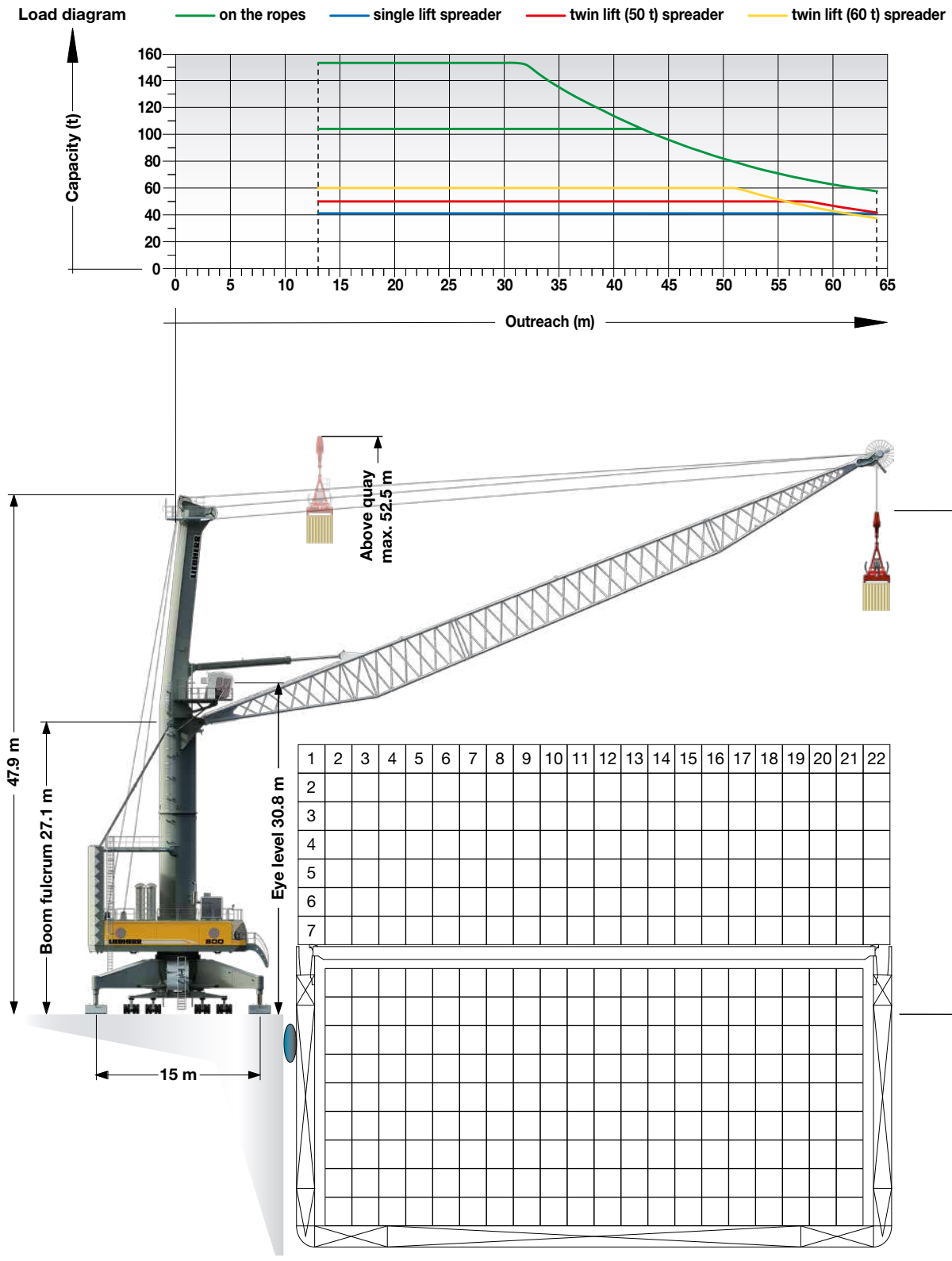

Lifting capacities

Hook & container operation LHM 800

Maximum crane capacity 104 t

Outreach	Hook operation on the ropes	Spreader operation under		
	Standard	Single lift	Twin lift	Twin lift
(m)	(t)	(t)	(t)	(t)
13 - 42	104.0	41.0	50.0	60.0
43	103.0	41.0	50.0	60.0
44	99.6	41.0	50.0	60.0
45	96.4	41.0	50.0	60.0
46	93.3	41.0	50.0	60.0
47	90.3	41.0	50.0	60.0
48	87.6	41.0	50.0	60.0
49	84.8	41.0	50.0	60.0
50	82.3	41.0	50.0	60.0
51	79.9	41.0	50.0	60.0
52	77.4	41.0	50.0	60.0
53	75.1	41.0	50.0	59.6
54	73.1	41.0	50.0	57.6
55	71.2	41.0	50.0	55.7
56	69.2	41.0	50.0	53.7
57	67.6	41.0	50.0	52.1
58	65.9	41.0	50.0	50.4
59	64.4	41.0	50.0	48.9
60	62.9	41.0	48.7	47.4
61	61.6	41.0	47.4	46.1
62	60.3	41.0	46.1	44.8
63	59.1	41.0	44.9	43.6
64	57.9	41.0	43.7	42.4

Weight rotator 3.5 t
 Weight fully automatic (telescopic) spreader 9.0 t
 Weight twin lift (50 t) spreader 10.7 t
 Weight twin lift (60 t) spreader 12.0 t

Maximum crane capacity 154 t

Outreach	Hook operation on the ropes	Spreader operation under		
	Standard	Single lift	Twin lift	Twin lift
(m)	(t)	(t)	(t)	(t)
13 - 31	154.0	41.0	50.0	60.0
32	152.5	41.0	50.0	60.0
36	130.8	41.0	50.0	60.0
40	114.2	41.0	50.0	60.0
43	103.0	41.0	50.0	60.0
44	99.6	41.0	50.0	60.0
46	93.3	41.0	50.0	60.0
48	87.6	41.0	50.0	60.0
50	82.3	41.0	50.0	60.0
51	79.9	41.0	50.0	60.0
52	77.4	41.0	50.0	60.0
53	75.1	41.0	50.0	59.1
54	73.1	41.0	50.0	57.1
55	71.2	41.0	50.0	55.2
56	69.2	41.0	50.0	53.2
57	67.6	41.0	50.0	51.6
58	65.9	41.0	50.0	49.9
59	64.4	41.0	49.7	48.4
60	62.9	41.0	48.2	46.9
61	61.6	41.0	46.9	45.6
62	60.3	41.0	45.6	44.3
63	59.1	41.0	44.4	43.1
64	57.9	41.0	43.2	41.9

Weight rotator 4.0 t
 Weight fully automatic (telescopic) spreader 9.0 t
 Weight twin lift (50 t) spreader 10.7 t
 Weight twin lift (60 t) spreader 12.0 t

Standard configuration Turnover up to 34 boxes per hour
 Pactronic® Turnover up to 40 boxes per hour

Precision to perfection: With incredibly short acceleration times for all crane motions, Liebherr is the top performer in container handling.

- The Pactronic® Hybrid Drive System is characterized by an energy storage device, which is added to the drive system as a secondary energy source. This results in substantially higher hoisting and lowering speeds. Not only is the crane's efficiency increased, but also the turnover (+30%). In addition, the crane's energy consumption is significantly reduced (-30%).
- Liebherr Cycoptronic® is an accurate, sway-free load motion control system that uses in-house designed software. Cycoptronic® allows for direct load positioning and aids the crane driver in mastering his task. With Cycoptronic® turnover, safety and the confidence of the operator will be improved.
- When loading/unloading containers, the crane driver needs to slew the crane causing the container to deviate from its parallel position to the vessel. With the Advanced Container Control System the container remains parallel to the vessel which eases the positioning for the crane driver and boosts handling figures.
- The Liebherr hydrostatic drive is the most reliable and highest performing drive system for mobile harbour cranes. Independent closed loop hydraulic systems utilize the minimum number of components to guarantee highly responsive, smooth and precise operation while maximizing operational safety.

Main dimensions

Bulk operation LHM 800

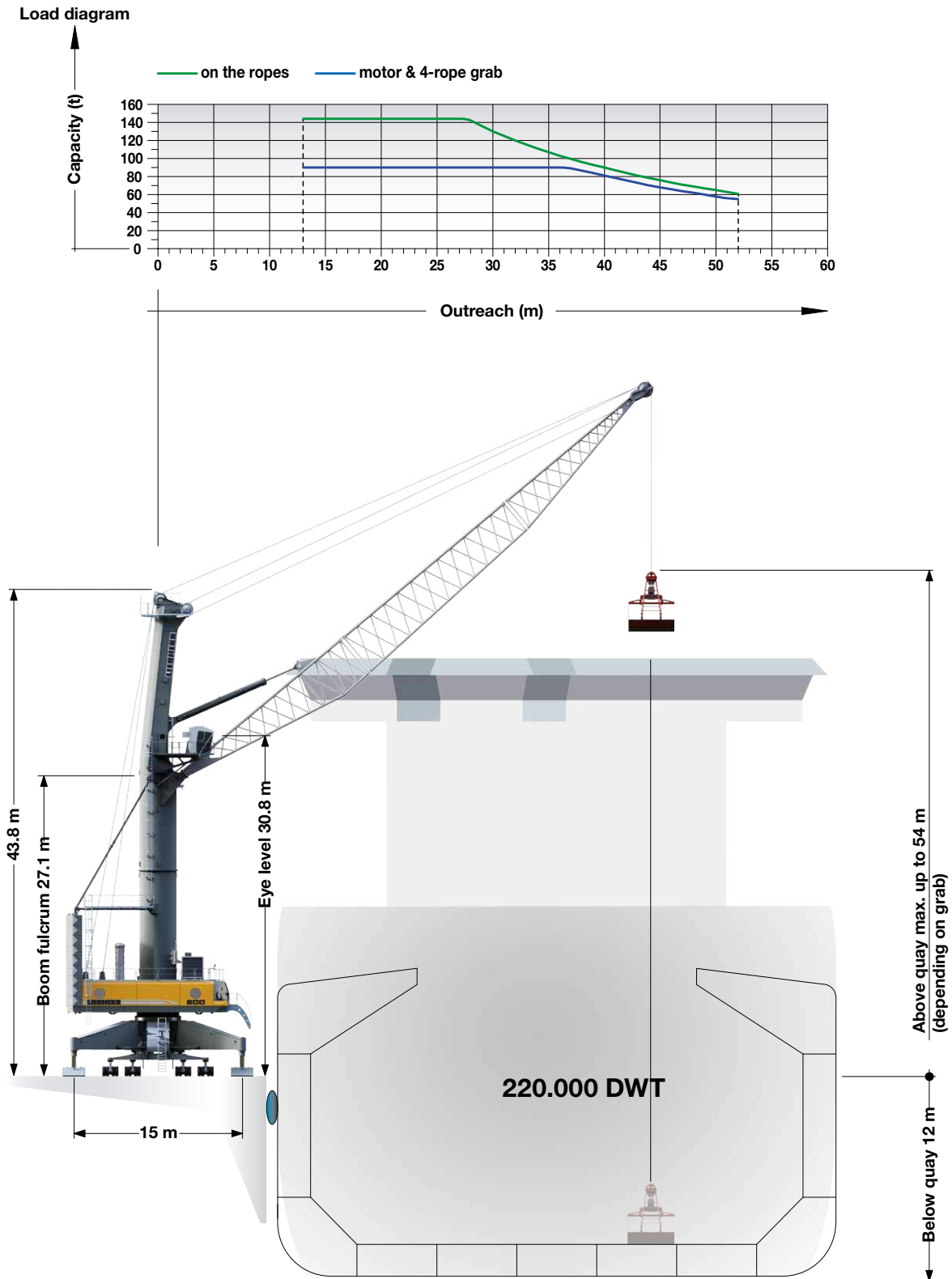

Lifting capacities

Bulk operation LHM 800

Maximum crane capacity 144 t

Outreach (m)	Hook operation	Grab operation on the ropes	
	on the ropes (t)	4-rope grab (t)	motor grab (t)
13 - 27	144.0	90.0	90.0
28	142.2	90.0	90.0
30	130.8	90.0	90.0
32	120.5	90.0	90.0
33	115.7	90.0	90.0
34	111.2	90.0	90.0
35	107.2	90.0	90.0
36	103.4	90.0	90.0
37	99.9	89.9	89.9
38	96.6	86.9	86.9
39	93.5	84.1	84.1
40	90.2	81.2	81.2
41	87.2	78.5	78.5
42	84.2	75.8	75.8
43	81.4	73.2	73.2
44	78.7	70.8	70.8
45	76.1	68.5	68.5
46	73.7	66.3	66.3
47	71.3	64.2	64.2
48	69.2	62.3	62.3
49	67.0	60.3	60.3
50	65.0	58.5	58.5
51	63.1	56.8	56.8
52	61.2	55.1	55.1

Weight ramshorn hook 3.8 t

Weight rotator 4.0 t

Standard configuration Turnover up to 1800 t per hour

Pactronic® Turnover up to 2300 t per hour

The powerful hydrostatic transmission and advanced Liebherr electronics ensure short, productive working cycles during bulk handling.

- The Pactronic® Hybrid Drive System is characterized by an energy storage device, which is added to the drive system as a secondary energy source. This results in substantially higher hoisting and lowering speeds. Not only is the crane's efficiency increased, but also the turnover (+30%). In addition, the crane's energy consumption is significantly reduced (-30%).
- During grab operation, hoisting, slewing and luffing are driven simultaneously at maximized speed to achieve the highest (possible) turnover.
- During grab filling, features such as automatic lowering and hoisting guarantee the optimum filling level of the grab.
- The slack rope monitoring system ensures extended lifetime of the ropes and increases operational safety.
- Reverse power is returned to the drive process through closed loop hydraulics which results in reduced fuel consumption.
- The Cycloptronic® anti-sway system automatically compensates for all rotational swing, transverse and longitudinal sway of the load at maximum speeds.
- To provide safe and stress-free working conditions for the operator, Liebherr offers the Cycloptronic® including Teach-In feature, a semi-automatic system, which pilots the crane from the vessel hatch to the quay without any sway. Especially for bulk operation into hoppers, the Teach-In system increases turnover and ensures consistent turnover rates during the entire ship unloading.

Technical data

Heavy duty operation LHM 800

Capacity and Classification

	Capacity	Classification
Heavy lift	308 t	A2
Standard operation	< 154 t	A5
Container	< 90 t	A8

Main dimensions

Min. to max. outreach	13–64 m
Height of boom fulcrum	27.1 m
Tower cabin height (eye level)	30.8 m
Overall height (top of tower)	47.9 m
Overall length of undercarriage	23.0 m
Overall width of undercarriage	10.3 m
Number of axle sets (standard)	34
Number of axle sets (optional)	40

Working speeds

Hoisting / lowering	0 – 90 m/min
Slewing	0 – 1.6 rpm
Luffing (average horizontal speed)	51 m/min
Travelling	0 – 4 km/h

Optional equipment

1. Pactronic® - power by accumulator and electronics
2. SmartGrip - intelligent grabbing
3. Cycoptronic® - anti-sway system
4. Teach-In - semi-automatic point to point system
5. Sycratronic® - synchronizing crane control system
6. Vertical Line Finder - diagonal pull preventing system
7. Dynamic anti-collision system
8. Lidat® - basic package
9. Lidat® - tele service package
10. Lidat® - turnover package
11. Economy software - for optimised fuel consumption
12. Video monitoring system
13. Radio remote control
14. Autopropping undercarriage
15. Cyclone air-intake system for the engine
16. Low temperature package
17. Customer-specific painting & logo
18. Additional (driven) axle sets
19. Axle sets equipped with foamed tyres
20. Different supporting bases and pad sizes
21. Tower extension 9.6 m
22. And many more as per customers' requirements

Propping arrangements

Standard supporting base	15 m x 15 m
Standard pad dimension	4 x 8 m x 2 m
Standard supporting area of pads	16 m ²

Optional size of supporting pads and bases on request

Quay load arrangements

Uniformly distributed load	2.74 t/m ²
Max. load per tyre	6 t

Due to a unique undercarriage design the quay loads specified above can even be reduced. Pad sizes, supporting base and the number of axle sets can easily be adapted to comply with the most stringent quay load restrictions.

Weight

Total weight of crane with 64 m boom	approx. 765 t
--------------------------------------	---------------

Hoisting heights

Above quay at minimum radius	48.0 m
Above quay at minimum radius	46.0 m
Below quay level	12.0 m

Technical data

Hook & container operation LHM 800

Capacity and classification

	Capacity	Classification
Standard operation	< 154 t	A3
Standard operation	< 95 t	A5
Container	< 63 t	A7

Main dimensions

Min. to max. outreach	13–64 m
Height of boom fulcrum	27.1 m
Tower cabin height (eye level)	30.8 m
Overall height (top of tower)	47.9 m
Overall length of undercarriage	23.0 m
Overall width of undercarriage	10.3 m
Number of axle sets (standard)	32
Number of axle sets (optional)	40

Working speeds

Hoisting / lowering	0 – 120 m/min
Slewing	0 – 1.6 rpm
Luffing (average horizontal speed)	66 m/min
Travelling	0 – 4 km/h

Propping arrangements

Standard supporting base	15 m x 15 m
Standard pad dimension	4 x 8 m x 2 m
Standard supporting area of pads	16 m ²

Optional size of supporting pads and bases on request

Quay load arrangements

Uniformly distributed load	2.24 t/m ²
Max. load per tyre	6.0 t

Due to a unique undercarriage design the quay loads specified above can even be reduced. Pad sizes, supporting base and the number of axle sets can easily be adapted to comply with the most stringent quay load restrictions.

Weight

Total weight of crane LHM 800 container version with 64 m boom	approx. 722 t
--	---------------

Hoisting heights

Above quay at minimum radius	52.5 m
Above quay at maximum radius	46.0 m
Below quay level	12.0 m

Optional equipment

1. Pactronic® - power by accumulator and electronics
2. SmartGrip - intelligent grabbing
3. Cycoptronic® - anti-sway system
4. Teach-In - semi-automatic point to point system
5. Sycratronic® - synchronizing crane control system
6. Vertical Line Finder - diagonal pull preventing system
7. Dynamic anti-collision system
8. Lidat® - basic package
9. Lidat® - tele service package
10. Lidat® - turnover package
11. Economy software - for optimised fuel consumption
12. Video monitoring system
13. Radio remote control
14. Autopropping undercarriage
15. Cyclone air-intake system for the engine
16. Low temperature package
17. Customer-specific painting & logo
18. Additional (driven) axle sets
19. Axle sets equipped with foamed tyres
20. Different supporting bases and pad sizes
21. Tower extension 9.6 m
22. And many more as per customers' requirements

Technical data

Bulk operation LHM 800

Capacity and classification

	Capacity	Classification
Grab operation	< 95 t	A6
Grab operation	< 63 t	A8

Main dimensions

Min. to max. outreach	12–52 m
Height of boom fulcrum	27.1 m
Tower cabin height (eye level)	30.8 m
Overall height (top of tower)	43.8 m
Overall length of undercarriage	23.0 m
Overall width of undercarriage	10.3 m
Number of axle sets (standard)	28
Number of axle sets (optional)	40

Working speeds

Hoisting / lowering	0 – 140 m/min
Slewing	0 – 1.6 rpm
Luffing (average horizontal speed)	60 m/min
Travelling	0 – 4 km/h

Optional equipment

1. Pactronic® - power by accumulator and electronics
2. SmartGrip - intelligent grabbing
3. Cycoptronic® - anti-sway system
4. Teach-In - semi-automatic point to point system
5. Sycratronic® - synchronizing crane control system
6. Vertical Line Finder - diagonal pull preventing system
7. Dynamic anti-collision system
8. Lidat® - basic package
9. Lidat® - tele service package
10. Lidat® - turnover package
11. Economy software - for optimised fuel consumption
12. Video monitoring system
13. Radio remote control
14. Autopropping undercarriage
15. Cyclone air-intake system for the engine
16. Low temperature package
17. Customer-specific painting & logo
18. Additional (driven) axle sets
19. Axle sets equipped with foamed tyres
20. Different supporting bases and pad sizes
21. Tower extension 9.6 m
22. And many more as per customers' requirements

Propping arrangements

Standard supporting base	15 m x 15 m
Standard pad dimension	4 x 8 m x 2 m
Standard supporting area of pads	16 m ²

Optional size of supporting pads and bases on request

Quay load arrangements

Uniformly distributed load	1.89 t/m ²
Max. load per tyre	6 t

Due to a unique undercarriage design the quay loads specified above can even be reduced. Pad sizes, supporting base and the number of axle sets can easily be adapted to comply with the most stringent quay load restrictions.

Weight

Total weight of crane	approx. 652 t
-----------------------	---------------

Hoisting heights

Above quay at minimum radius	54.0 m
Above quay at minimum radius	43.6 m
Below quay level	12.0 m

Undercarriage

Mobility

- Outstanding mobility and manoeuvrability
- Curves at any possible radii and even slewing on the spot

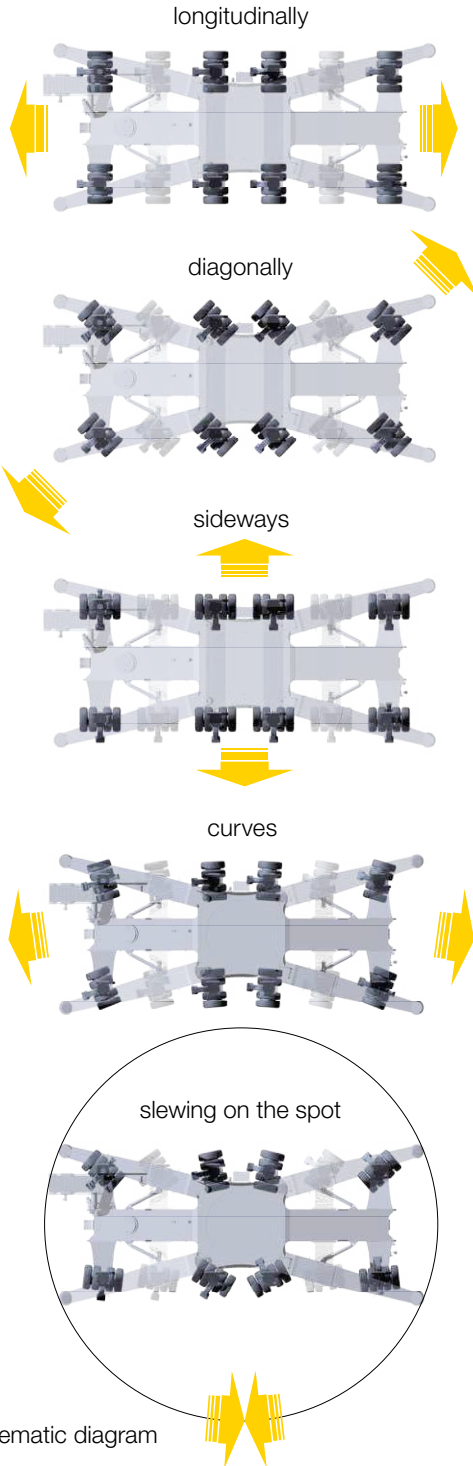

Modular propping system

- Minimised stress and strain of undercarriage due to cruciform support base which directs the load path from boom tip to quay
- Modular system allows further reduction of quay loads by installing additional axle sets
- Easy adaptation to various sizes of support pads and bases

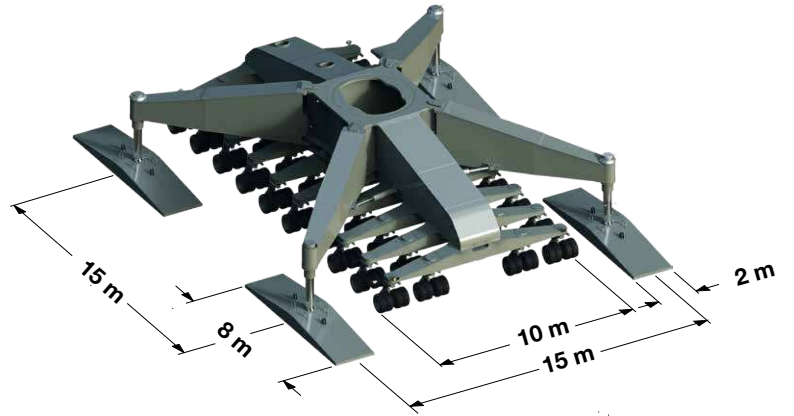

Hydraulic load distribution

- Hydraulic suspension avoids overloading of individual wheel sets
- Standard trailer tyres making requisition of spares economical and time-saving
- Increased lifetime of tyres due to individually steerable wheel sets

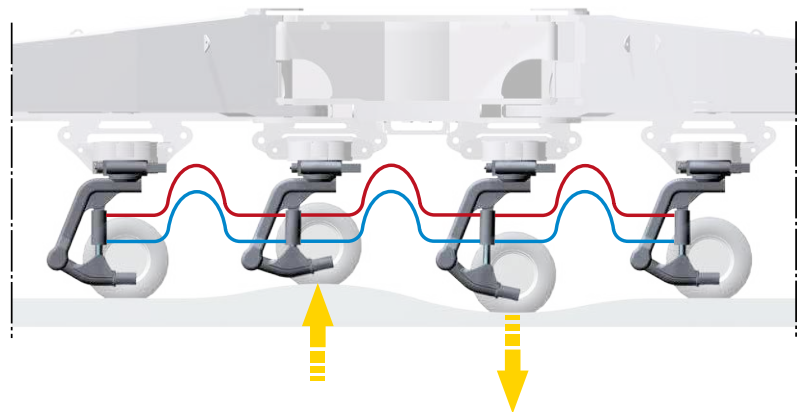

Optimum pressure distribution and adaption of wheel sets on uneven surfaces

Practical solutions



Liebherr develops and produces special designs and solutions to meet customer-specific requirements

- The Liebherr Portal Crane, LPS, is an efficient combination of a space-saving portal (mounted on rails) and the proven mobile harbour crane concept. Particularly on narrow quays, individual portal solutions permit (railway) trains and (road) trucks to travel below the portal.
- Liebherr barge cranes, LBS, can be used for transshipment and midstream operation between ocean-going vessels and river barges on different types of waterways, including those having no or few quays. In addition, the LBS solution allows direct cargo transfer from ship to shore – especially when quays reach capacity limits.
- Depending on customer specifications, the LBS range may have varying lifting capacities due to tailor-made design solutions.
- Liebherr Fixed Slewing Cranes (LFS) are an efficient combination of a mobile harbour crane upper carriage and a fixed pedestal. LFS cranes provide an economical and space-saving solution for the installation on quaysides and jetties, especially where room for manoeuvring is limited and low ground pressure is essential. Additionally LFS solutions are also ideally suited for the installation on crane barges.

Liebherr-MCCTec Rostock GmbH

Liebherrstraße 1, 18147 Rostock/GERMANY
 Tel.: +49 381 6006 5020
 mobile.harbour.crane@liebherr.com
 www.liebherr.com