

Technical data Hydraulic lift crane

Complies with ANSI B 30.5

LR 1100

Litronic®

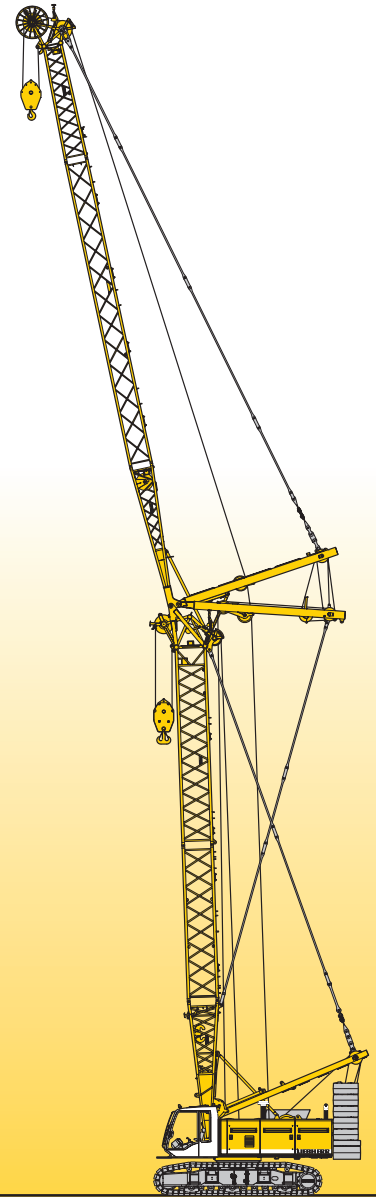

LIEBHERR

Courtesy of Crane.Market

Dimensions

Basic machine with undercarriage

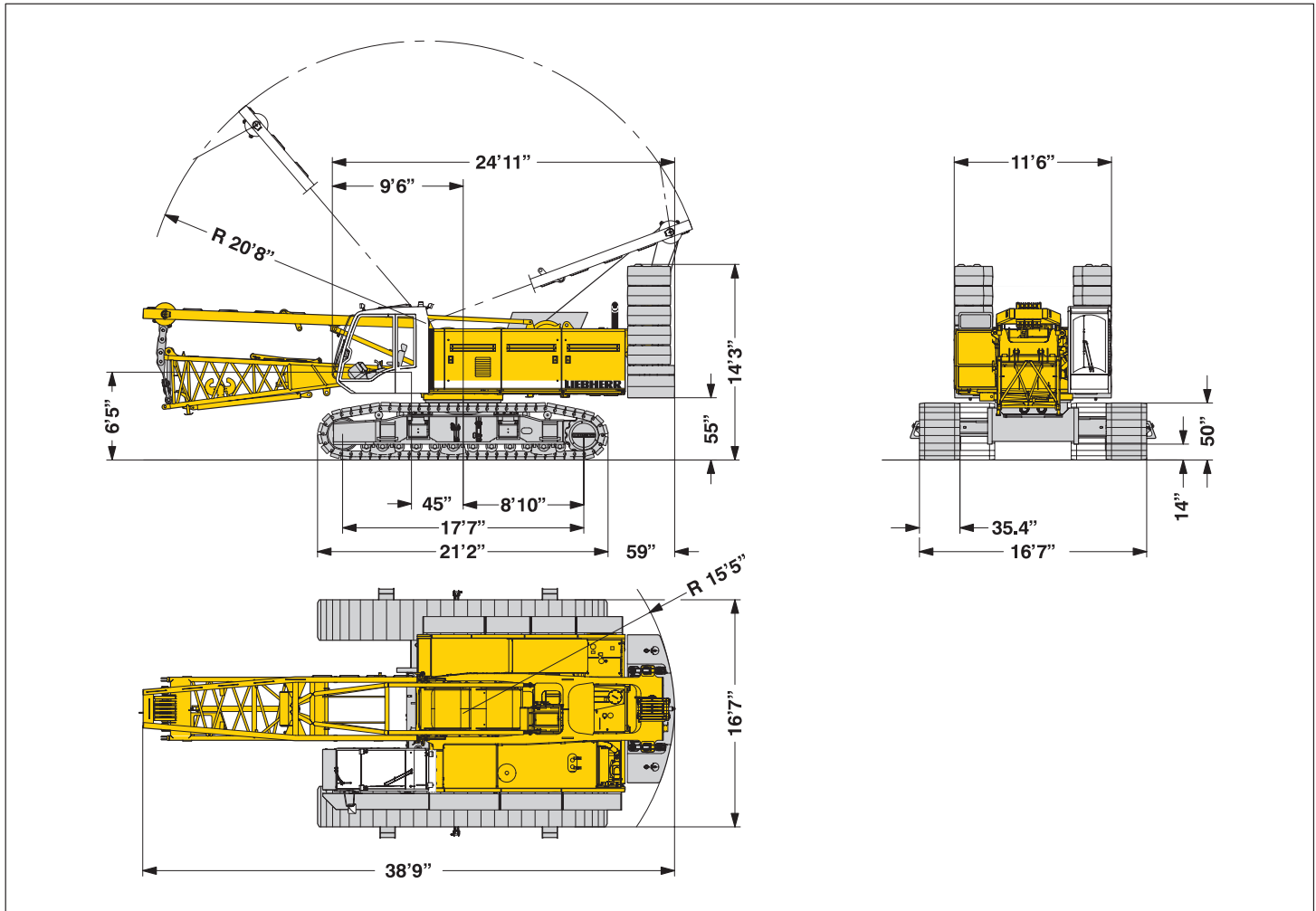

Operating weight

The operating weight includes the basic machine with crawlers, 2 main winches 26,500 lbs and 46 ft main boom, consisting of A-frame, boom foot (18 ft), boom head (28 ft), 71,200 lbs basic counterweight, 33,100 lbs carbody counterweight and 308,650 lbs hook block.

Total weight _____ appr. 242,100 lbs

Ground pressure

Ground bearing pressure _____ 16.21 psi

Equipment

Main boom (No. 1311.xx) max. length _____ 223 ft
 High reach (1311.xx and 1008.xx) _____ 272 ft
 Luffing jib (No. 1008.xx) max. length _____ 203 ft
 Max. combination _____ boom 125 ft and luffing jib 203 ft
 Luffing jib (No. 1309.xx) max. length _____ 219 ft
 Max. combination _____ boom 115 ft and luffing jib 219 ft
 Fixed jib (No. 0806.xx) _____ 36 ft – 105 ft
 Auxiliary jib 53,000 lbs lifting capacity (optional 79,100 lbs)

Remarks

1. The lifting capacities stated are valid for lifting operation only (corresponds with crane classification according to F.E.M. 1.001, crane group A1)
2. Crane standing on firm, horizontal ground.
3. The weight of the lifting device (hoisting ropes, hook block, shackle etc.) must be deducted from the gross lifting capacity to obtain a net lifting value.
4. Additional equipment on boom (e.g. boom walkways, auxiliary jib) must be deducted to get the net lifting capacity.
5. For max. wind speed please refer to lift chart in operator's cab or manual.
6. Working radii are measured from centre of swing and under load.
7. The lifting capacities are valid for 360 degrees of swing.
8. Calculation of stability under load is based on 75% tipping load, ANSI B 30.5 and ISO 4305 Table 2.
9. The structures are calculated according to F.E.M. 1.001 – 1998 (EN 13001-2 / 2004) and tested according to SAE J 987.

Transport dimensions and weights

Basic machine and boom (No. 1311.xx)

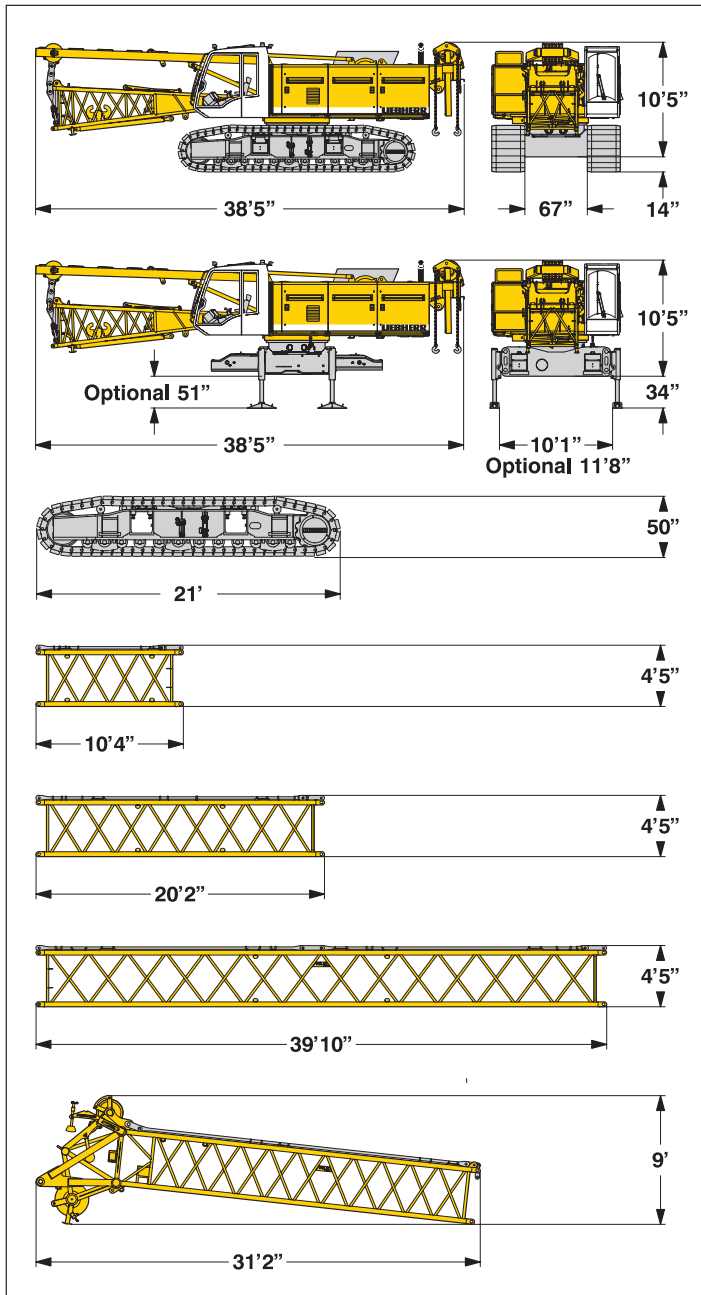

*) Including pendants

Basic machine

with HD undercarriage, boom foot (No. 1311.22), A-frame, 2x 26.500 lbs crane winches including wire ropes (853 ft), without basic counterweight

Width	11'6"
Weight in lbs	126,000

Basic machine

with boom foot (No. 1311.22), A-frame, 2x 26.500 lbs crane winches including wire ropes (853 ft), without basic counterweight and crawlers

Width	11'6"
Weight in lbs	81,020

Crawler

2x

Flat track shoes	35.4"
Width	36"
Weight in lbs	22,500

Boom section (No. 1311.22)

10 ft

Width	4'7"
Weight in lbs*	1,130

Boom section (No. 1311.22)

20 ft

Width	4'7"
Weight in lbs*	1,940

Boom section (No. 1311.21)

40 ft

Width	4'7"
Weight in lbs*	3,400

Boom head (No. 1311.24)

Width	5'9"
Weight in lbs*	5,180

Boom transport option

Length	39'10"
Weight in lbs*	13,600

Transport dimensions and weights

Luffing jib (No. 1008.xx)

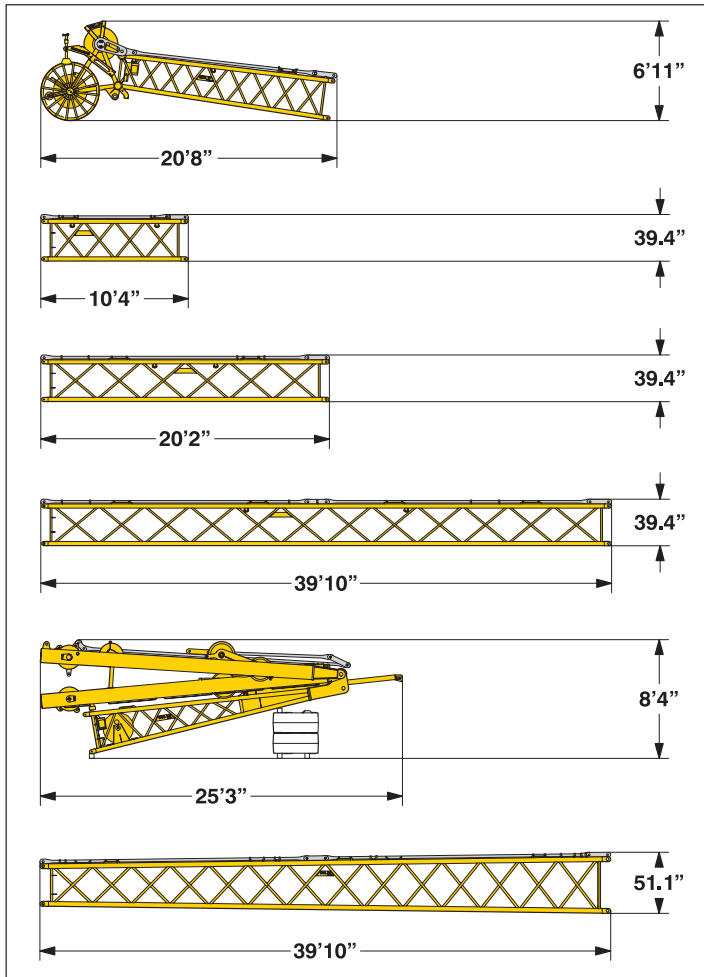

Luffing jib head (No. 1008.17)

Width	51.1"
Weight in lbs*	2,140

Luffing jib section (No. 1008.17) **10 ft**

Width	47.2"
Weight in lbs*	650

Luffing jib section (No. 1008.17) **20 ft**

Width	47.2"
Weight in lbs*	1,000

Luffing jib section (No. 1008.17) **40 ft**

Width	47.2"
Weight in lbs*	1,900

Luffing jib foot with A-frames (No. 1008.20)

Width	5'3"
Weight in lbs*	8,600

Boom section tapered (No. 1311/1008.21) **40 ft**

Width	4'7"
Weight in lbs*	2,550

Fixed jib (No. 0806.xx)

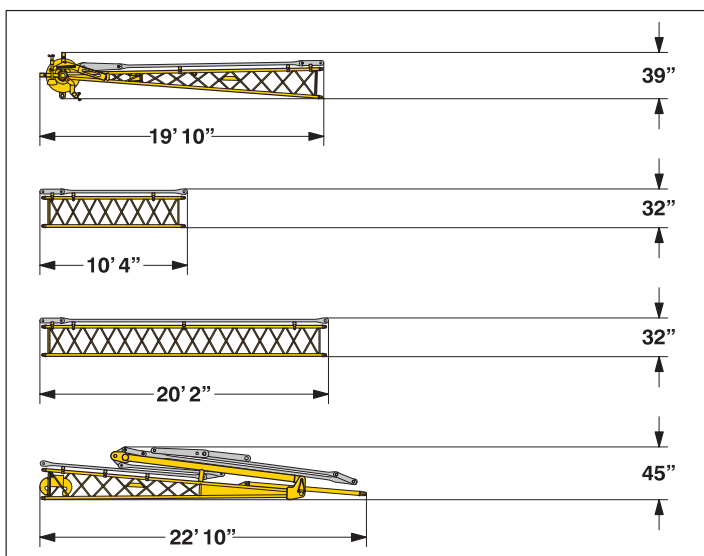

Fixed jib head (No. 0806.16)

Width	45"
Weight in lbs*	980

Fixed jib section (No. 0806.15) **10 ft**

Width	38"
Weight in lbs*	245

Fixed jib section (No. 0806.15) **20 ft**

Width	38"
Weight in lbs*	430

Fixed jib foot with A-frame (No. 0806.16)

Width	59"
Weight in lbs*	2,050

*) Including pendants

Transport dimensions and weights

Luffing jib (No. 1309.xx)

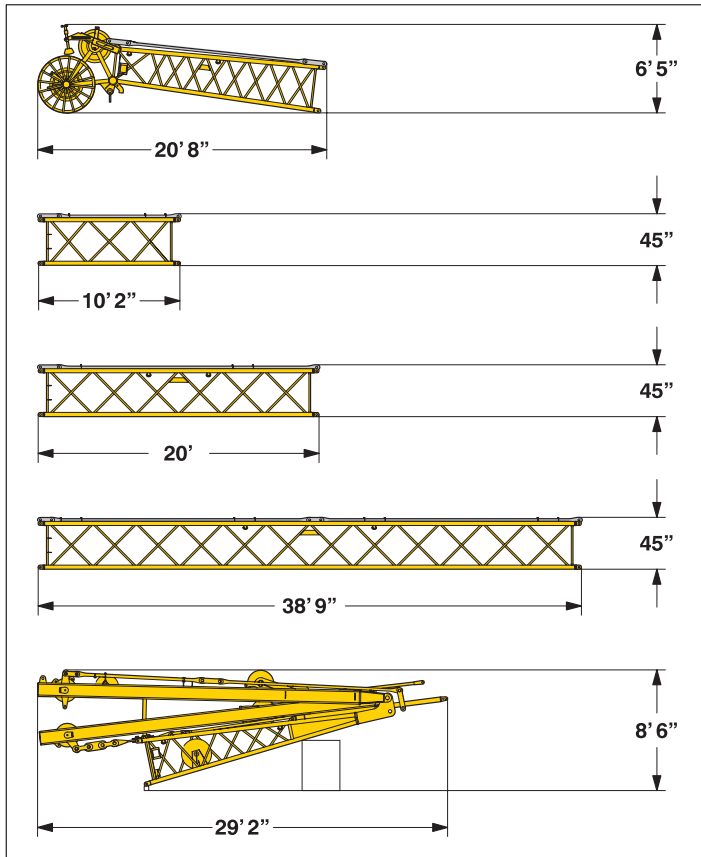

*) Including pendants

Luffing jib head (No. 1309.22)

Width	59"
Weight in lbs*	2,500

Luffing jib section (No. 1309.20) **10 ft**

Width	59"
Weight in lbs*	930

Luffing jib section (No. 1309.20) **20 ft**

Width	59"
Weight in lbs*	1,150

Luffing jib section (No. 1309.20) **38 ft**

Width	59"
Weight in lbs*	2,100

Luffing jib foot with A-frames (No. 1309.22)

Width	5'7"
Weight in lbs*	10,600

Transport dimensions and weights

Counterweight

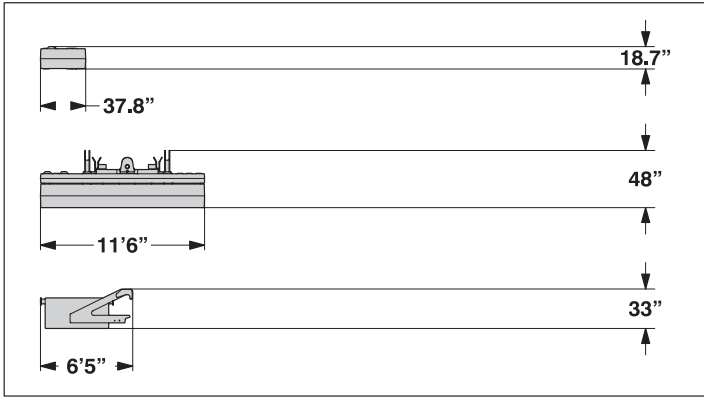

Counterweight

10x

Width	33.5"
Weight in lbs	3,300

Counterweight

1x

Width	41.3"
Weight in lbs	38,150

Carbody counterweight

2x

Width	5'5"
Weight in lbs	16,500

Hooks

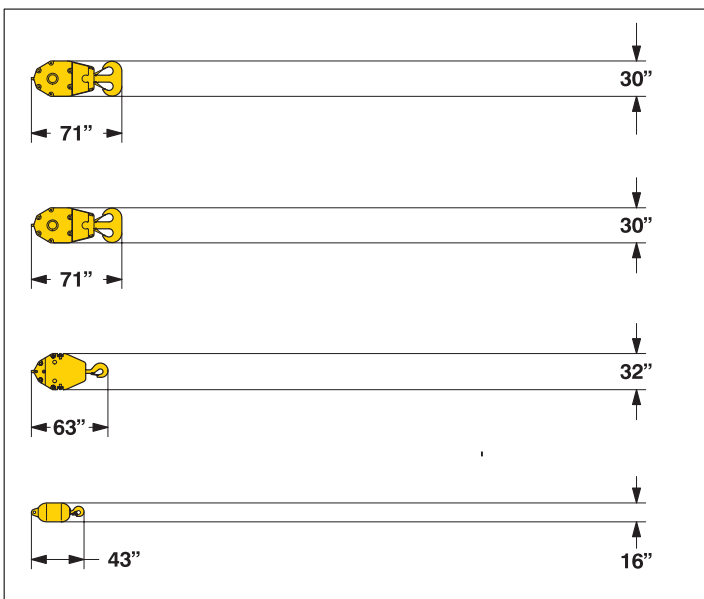

220.500 lbs hook block - 5 sheaves

Width	21.3" — 26.4" — 30.3"
Weight in lbs	2,870 — 3,970 — 5,070

176.400 lbs hook block - 3 sheave

Width	14.2" — 18.1" — 22"
Weight in lbs	2,200 — 3,310 — 4,410

88.200 lbs hook block - 1 sheave

Width	11.8" — 15.8" — 19.7"
Weight in lbs	1,550 — 2,425 — 3,310

27.600 lbs single hook

Width	15.8"
Weight in lbs	1,330

Technical description



Engine

Power rating according to ISO 9249, 270 kW (362 hp) at 2000 rpm
Engine type _____ Liebherr D 936 L A6
Fuel tank _____ 219 gal capacity with continuous level indicator and reserve warning
Engine complies with NRMM exhaust certification EPA / CARB Tier 3 and 97/68 EC Stage III



Hydraulic system

A double axial displacement pump supplies the open loop hydraulic system, allowing all functions to be operated simultaneously. To minimize peak pressure an automatic working pressure cut-off is integrated in the pump. All filters are electronically monitored.
The use of synthetic environmentally friendly (biodegradable) oils is possible.
Working pressure _____ max. 5080 PSI
Oil tank capacity _____ 172 gal



Luffing jib winch

Line pull _____ max. 23,150 lbs
Rope diameter _____ 20 mm
Jib luffing _____ 48 sec. from 15° to 78°



Boom winch

Line pull _____ max. 27,800 lbs
Rope diameter _____ 20 mm
Boom up _____ 44 sec. from 15° to 86°



Swing

Consists of rollerbearing with external teeth, swing drive with fixed axial piston hydraulic motor, spring loaded and hydraulically released multi-disc holding brake, planetary gearbox and pinion.
Both swing modes are possible – speed control or free swing.
A multi-disc holding brake acts automatically at zero swing motion.
Swing speed from 0 – 1.8 rpm continuously variable.



Main winches

Line pull (1st layer) _____ max. 38,600 lbs
Line pull (7th layer) _____ 26,500 lbs
Rope diameter _____ 26 mm
Drum diameter _____ 22 inch
Rope speed ft/min _____ 0 – 446
Rope capacity in 7 layers _____ 1600 ft
The winches are outstanding in their compact design and easy assembly. Propulsion is via a planetary gearbox in an oil bath.
Load support by the hydraulic system; additional safety factor provided by a spring loaded, multi-disc holding brake.
The main winches use pressure controlled, variable flow hydraulic motors. This system features sensors that automatically adjust oil flow to provide max. winch speed depending on load.
Option – winch with freefall system:
Clutch and braking functions on the freefall system are provided by a compact designed, low wear and maintenance free multi-disc brake.



Crawlers

Propulsion through axial piston motor, hydraulically released spring loaded multi-disc brake, crawler tracks, hydraulic chain tensioning device.
Flat track shoes _____ 35.4 inch
Drive speed _____ 0 – 0.85 mph



Control

The control system – developed and manufactured by Liebherr – is designed to withstand extreme environmental conditions such as temperature, vibration and electromagnetic interference and to meet all requirements that are needed in heavy duty crane operation.
Complete machine operating data are shown on a high resolution display. Standard operational information is displayed by means of graphical symbols, fault indications are displayed in plain text (more than 15 languages available).
The cranes are equipped with proportional control for all main movements, which can be carried out simultaneously.
The crane is operated with 2 multi-directional joysticks, the right for winch I and boom, the left for winch II and swing control.
Option:
Bi-directional double T-levers for simultaneous boom and luffing jib operation.
The crawlers are activated by the two central foot pedals. Additionally, hand levers can be attached to the pedals.
Remote control for assembly of counterweight.



Noise emission

Noise emissions correspond with 2000/14/EC directive on noise emission by equipment used outdoors.

Boom combinations

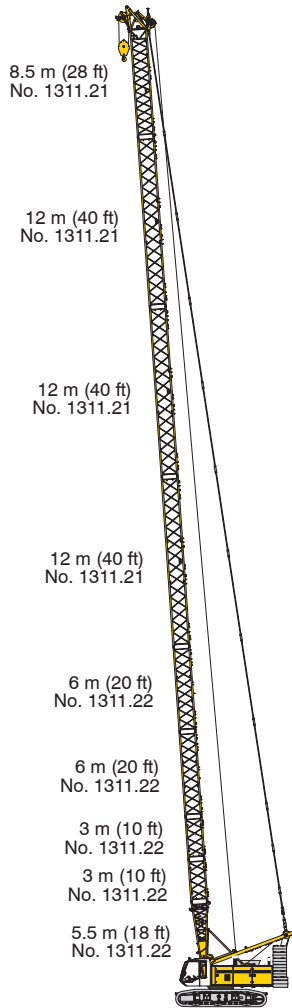

Main boom No. 1311.xx — 223 ft

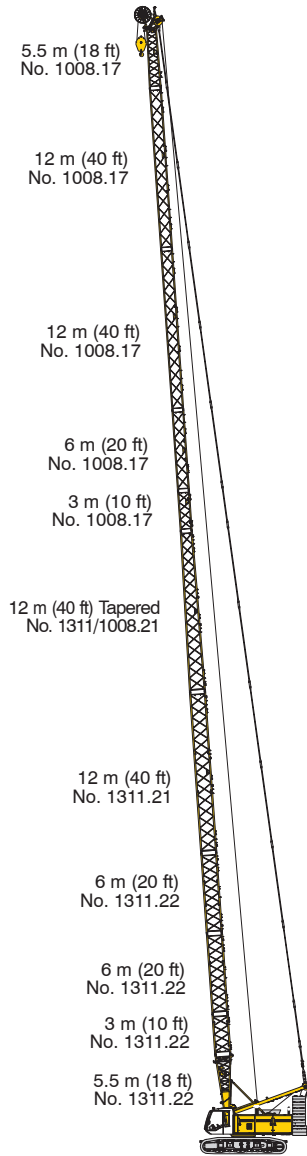

Max. combination — 272 ft
Main boom No. 1311.xx — 106 ft
Tapered No. 1311/1008.xx 40 ft
Luffing jib No. 1008.xx — 126 ft

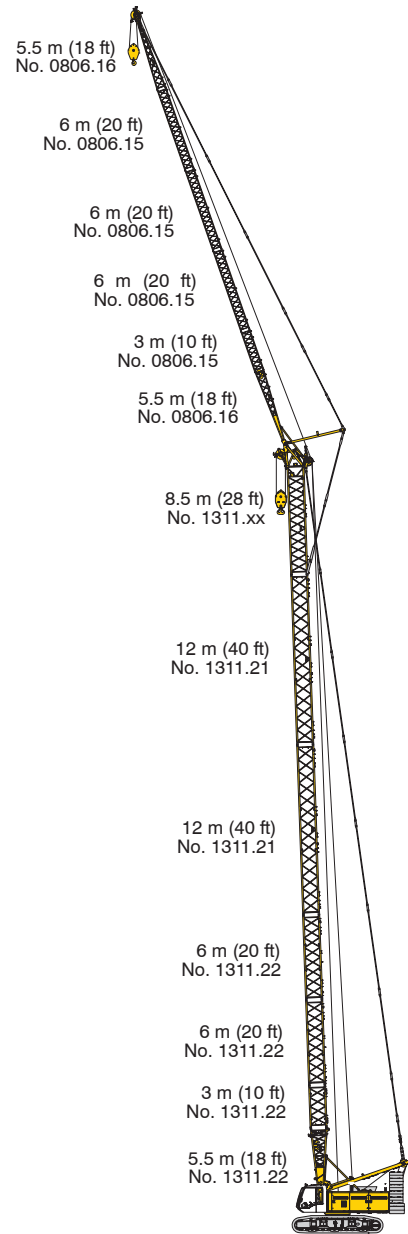

Max. combination 279 ft
Main boom No. 1311.xx — 174 ft
Fixed jib No. 0806.xx — 105 ft

Boom combinations

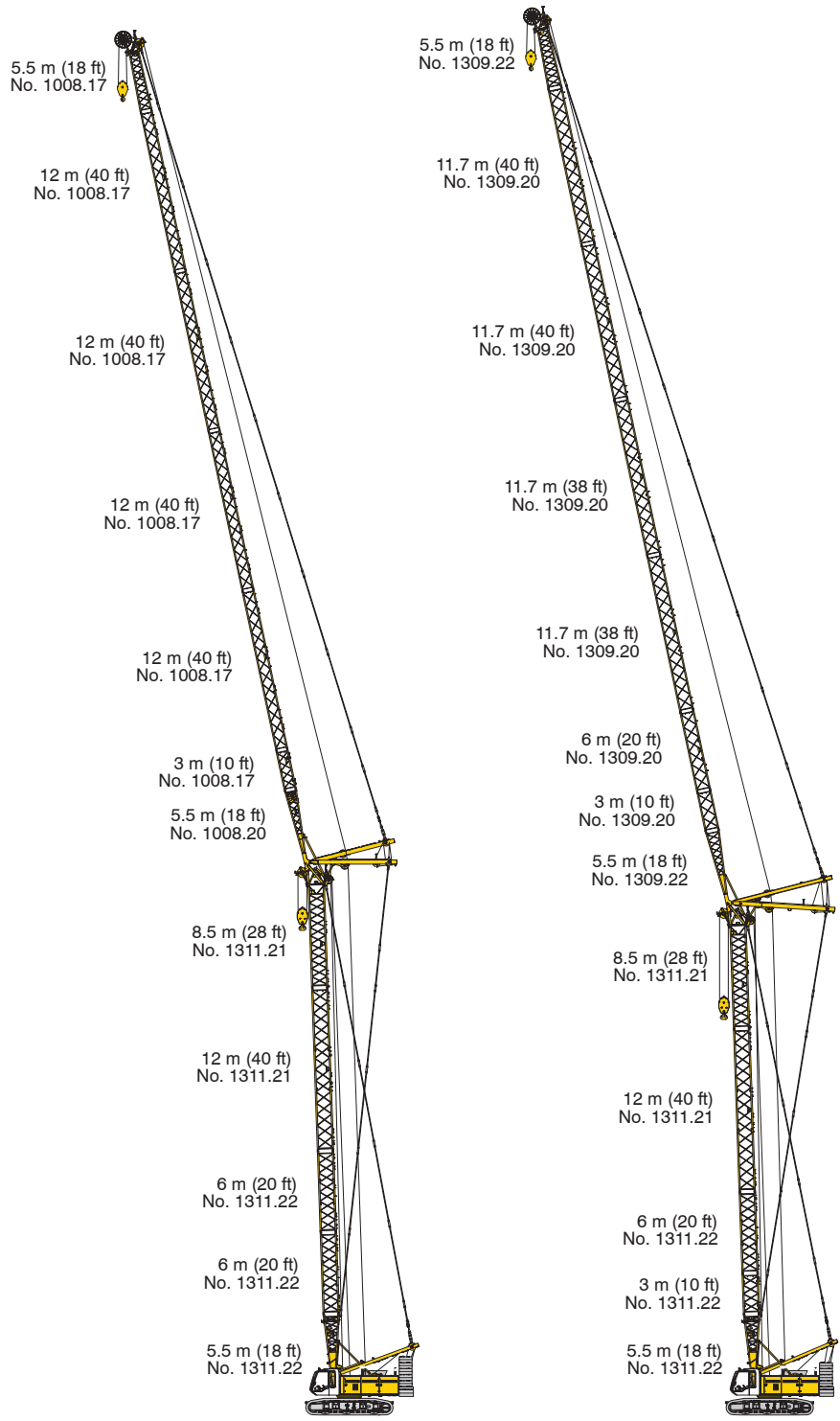

Max. combination — 328 ft
 Main boom No. 1311.xx — 125 ft
 Luffing jib No. 1008.xx — 203 ft
 Main boom No. 1311.xx — 135 ft
 Luffing jib No. 1008.xx — 144 ft

Max. combination — 334 ft
 Main boom No. 1311.xx — 115 ft
 Luffing jib No. 1309.xx — 219 ft
 Main boom No. 1311.xx — 125 ft
 Luffing jib No. 1309.xx — 151 ft

Self assembly system

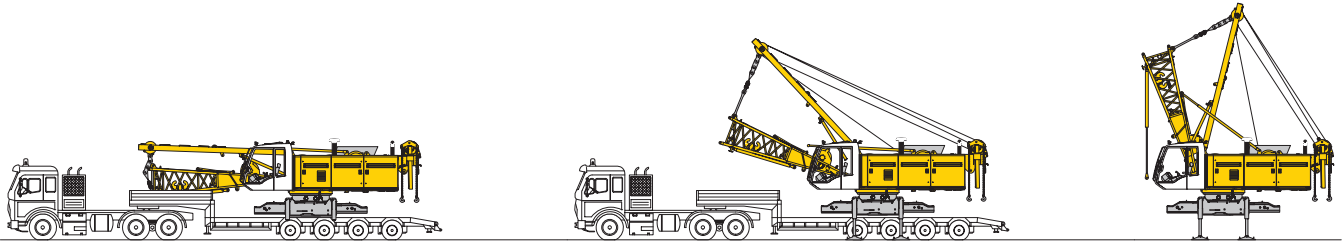

Unloading of basic machine (Optional)

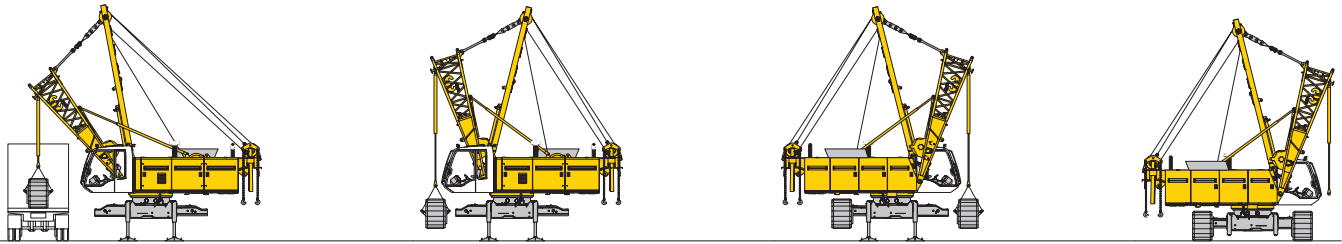

Unloading and assembly of crawlers

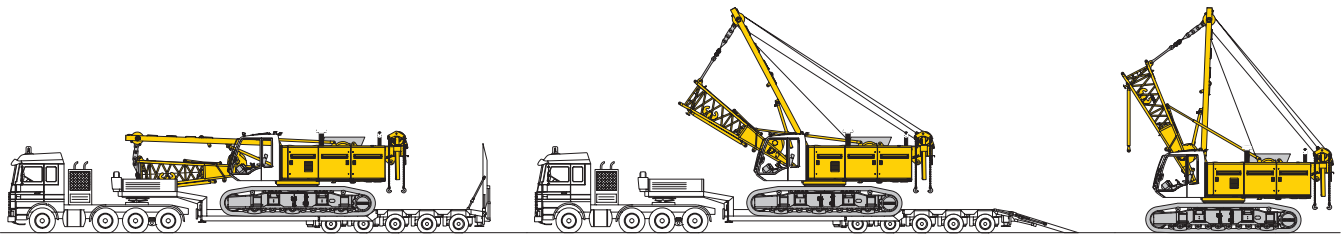

Unloading of basic machine (Standard)

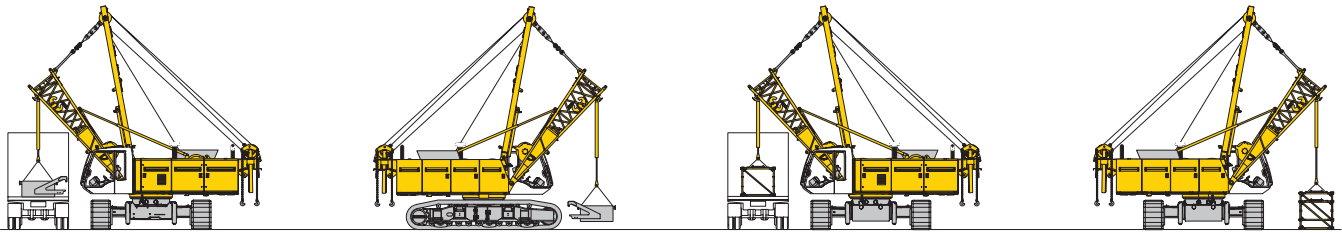

Unloading and assembly of carbody counterweight

Unloading and assembly of boom

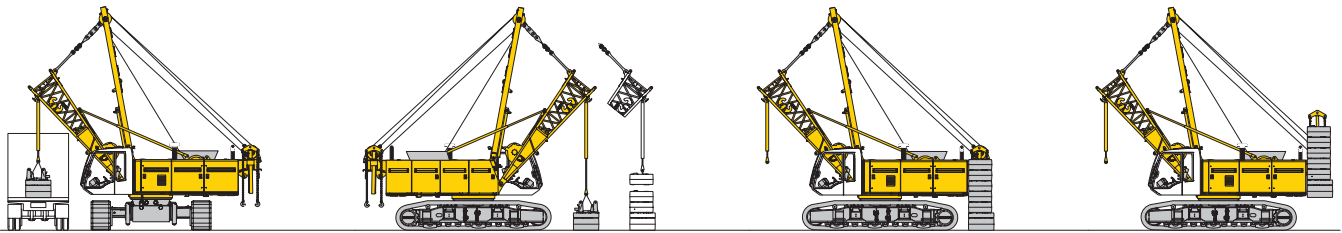

Unloading and assembly of counterweight

Erecting of main boom to working position

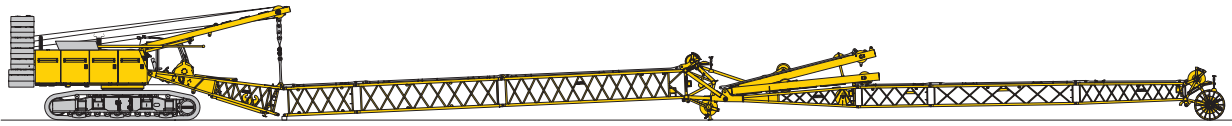

Assembly of boom

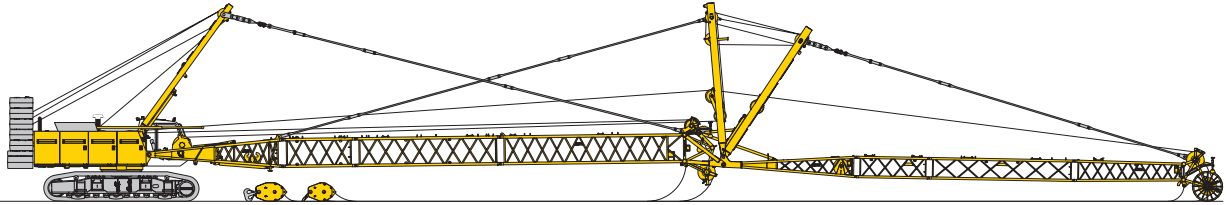

Reeving of hoist and jib ropes

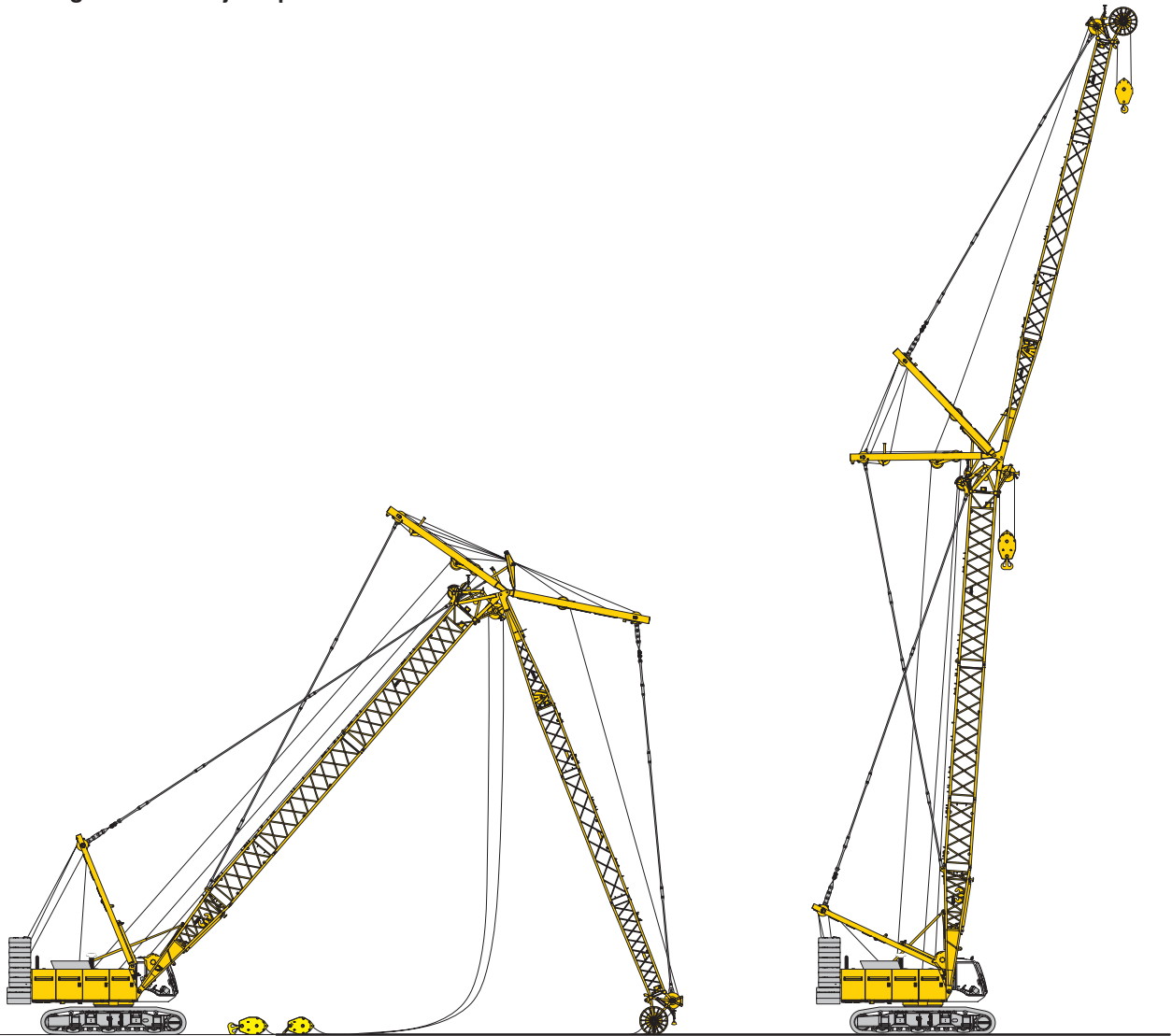

Erecting of main boom and luffing jib

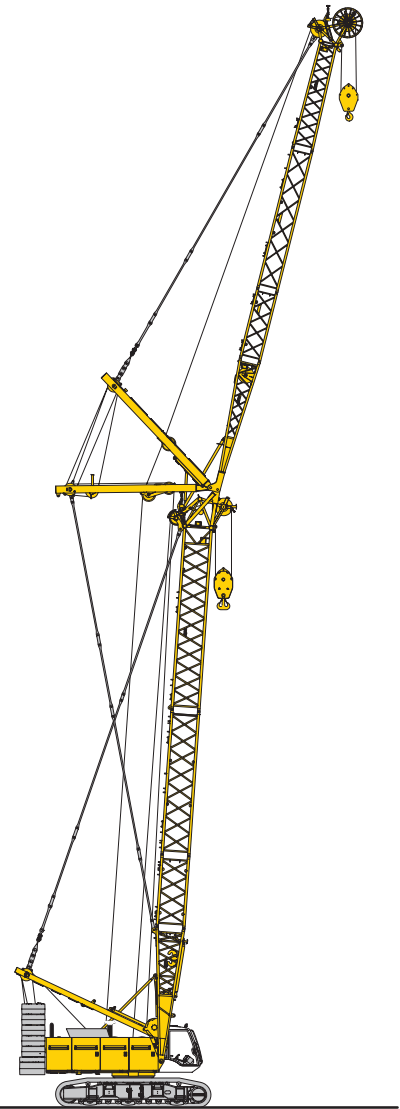

Working position

Working range - main boom (No. 1311.xx) 86° - 15°

71,200 lbs counterweight and 33,100 lbs carbody counterweight

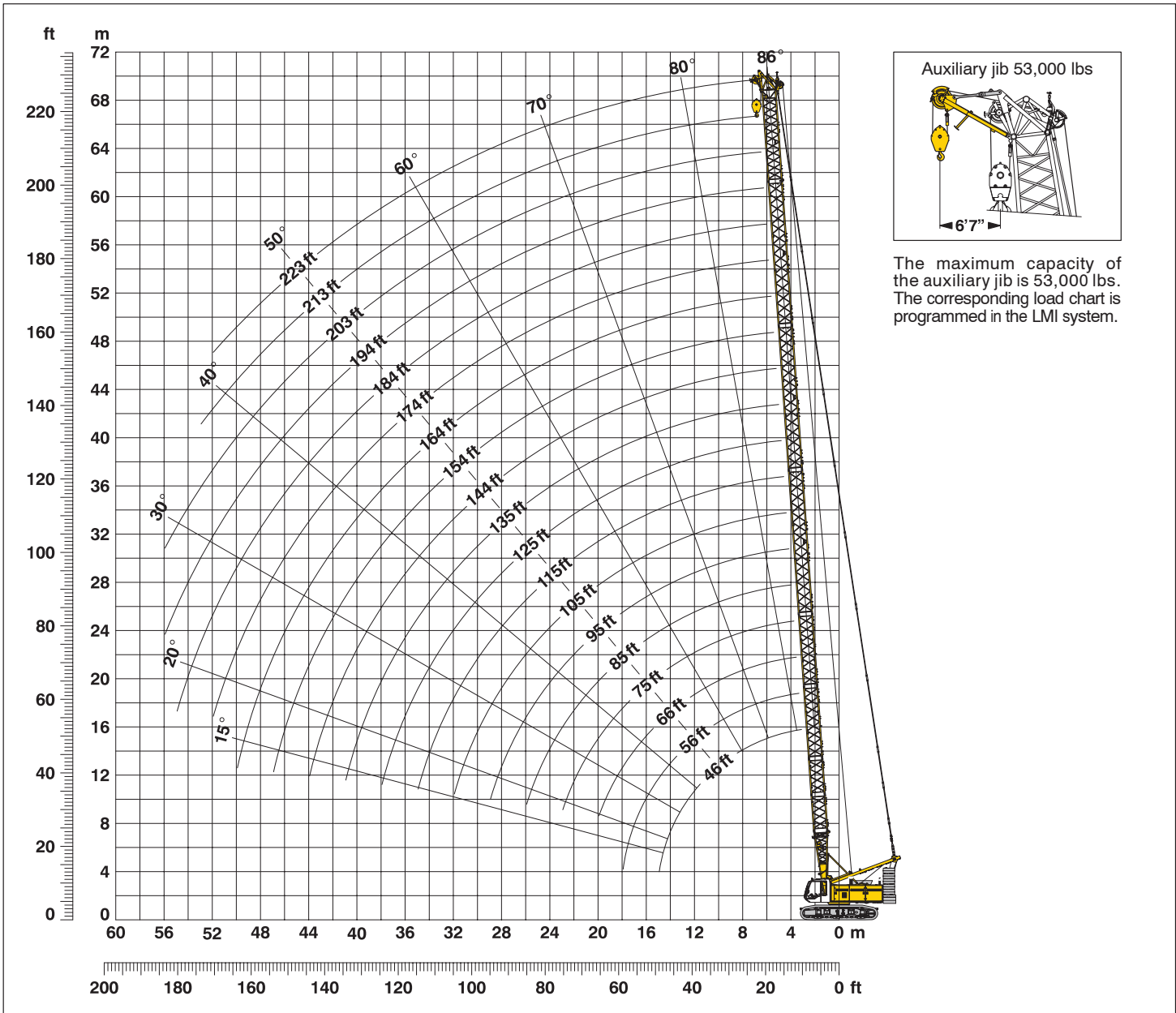

Main boom configuration (Table 1 - No. 1311.xx)

Configuration for boom lengths (46 ft – 223 ft)		Amount of boom extensions																		
Length		1	1	1	1	1	1	1	1	1	1	1	1	1	1	1	1	1	1	1
Boom foot	18 ft	1	1	1	1	1	1	1	1	1	1	1	1	1	1	1	1	1	1	1
Boom insert	10 ft*		1		1	1	1	1	1	1	1	1	1	1	1	1	1	1	1	2
Boom insert	20 ft*			1	1	2	2	1	1	2	2	1	1	2	2	1	1	2	2	2
Boom insert	40 ft*							1	1	1	1	2	2	2	2	3	3	3	3	3
Boom head	28 ft*	1	1	1	1	1	1	1	1	1	1	1	1	1	1	1	1	1	1	1
Boom length (ft)		46	56	66	75	85	95	105	115	125	135	144	154	164	174	184	194	203	213	223

*Actual lengths of boom sections are metric (e.g. 3 m, 6 m, 8.5 m, 12 m). The figures shown above are approximate conversions to feet.

Lift chart for main boom (No. 1311.xx)

Capacities in 1000 lbs for boom lengths (46 ft – 223 ft) – with 26,500 lbs winches
71,200 lbs counterweight and 33,100 lbs carbody counterweight

Radius	Boom length in (ft)										Radius
	46	66	85	105	125	144	164	184	203	223	
(ft)	lbs	lbs	lbs	lbs	lbs	lbs	lbs	lbs	lbs	lbs	(ft)
10.2	230.3										10.2
15	230.3	223.1	199.5	147.8							15
20	146.2	146.5	143.7	141.8	110.5	80.8	62.1	46.3			20
25	104.1	104.3	101.3	104.2	98.5	79.7	61.2	45.7	36.9	30.1	25
30	80.3	80.4	80.3	80.3	80.0	77.7	60.5	44.9	36.4	29.2	30
35	64.9	65.1	65.0	64.9	64.6	64.3	59.9	44.1	35.4	28.5	35
40	54.2	54.4	54.2	54.1	53.8	53.6	53.2	43.5	34.5	27.6	40
45	46.2	46.5	46.3	46.2	45.9	45.6	45.2	42.1	33.8	27.0	45
60		31.7	31.6	31.4	31.1	30.8	30.3	30.0	29.6	22.2	60
65		28.4	28.3	28.2	27.8	27.5	27.1	26.7	26.5	22.2	65
80			21.3	21.2	20.8	20.5	20.1	19.8	19.3	18.8	80
85			19.5	19.4	19.1	18.8	18.3	18.0	17.5	17.0	85
95				16.5	16.1	15.9	15.4	15.0	14.6	14.1	95
100				15.2	14.9	14.6	14.2	13.8	13.3	12.8	100
110					12.8	12.5	12.1	11.7	11.2	10.7	110
115					11.8	11.6	11.1	10.8	10.3	9.8	115
120					11.0	10.8	10.3	10.0	9.5	9.0	120
130						9.3	8.8	8.5	8.0	7.5	130
135						8.6	8.2	7.8	7.4	6.8	135
140						8.0	7.6	7.2	6.8	6.2	140
150							6.5	6.2	5.7	5.2	150
155							6.0	5.7	5.2	4.7	155
160							5.5	5.2	4.7	4.2	160
170								4.4	3.9	3.4	170
175								4.0	3.5	3.0	175
180								3.6	3.2	2.7	180
190									2.5	2.0	190
195									2.2		195

Above lift chart is for reference only. For actual lift duty please refer to lift chart in operator's cab or manual.

L – boom high reach (No. 1311 / 1008.xx) **164 ft - 272 ft**

Working range **86° - 15°**

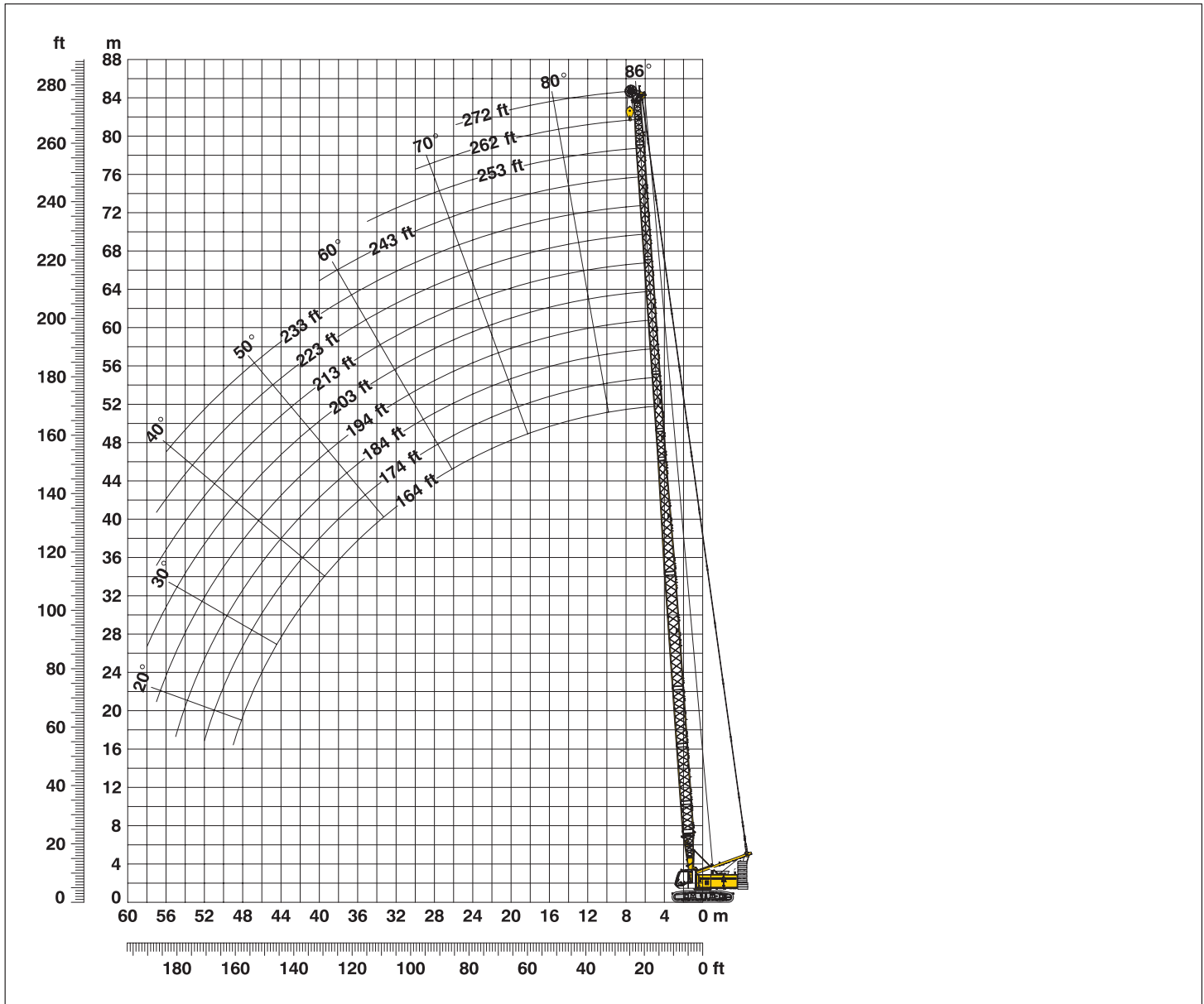

L – boom configuration with 107 ft main boom (No. 1311.xx / No. 1008.xx)

Configuration for L – boom lengths (164 ft – 272 ft)

Configuration	Length	Amount of boom and luffing jib extensions											
		1	1	1	1	1	1	1	1	1	1	1	1
Boom foot	18 ft	1	1	1	1	1	1	1	1	1	1	1	1
Boom insert	10 ft*	1	1	1	1	1	1	1	1	1	1	1	1
Boom insert	20 ft*	2	2	2	2	2	2	2	2	2	2	2	2
Boom insert	40 ft*	1	1	1	1	1	1	1	1	1	1	1	1
Tapered	40 ft*	1	1	1	1	1	1	1	1	1	1	1	1
Luffing insert	10 ft*		1		1		1		1		1		1
Luffing insert	20 ft*			1	1			1	1			1	1
Luffing insert	40 ft*					1	1	1	1	2	2	2	2
Luffing jib head	18 ft	1	1	1	1	1	1	1	1	1	1	1	1
Max. L – boom length (ft)		164	174	184	194	203	213	223	233	243	253	262	272

*Actual lengths of boom sections are metric (e.g. 3 m, 6 m, 12 m). The figures shown above are approximate conversions to feet.

Lift chart for L – boom (No. 1311 / 1008.xx)

Main boom length 107 ft

Capacities in 1000 lbs
71,200 lbs counterweight and 33,100 lbs carbody counterweight

Radius (ft)	Boom length in (ft)			
	164	203	243	272
	lbs	lbs	lbs	lbs
17	62.3			
20	62.0	35.0		
25	61.0	34.1	17.3	12.1
30	60.0	32.9	16.6	10.9
35	59.2	31.6	15.9	10.3
40	54.5	30.3	15.1	9.8
45	46.5	28.9	14.6	9.2
50	40.5	27.8	13.8	8.8
55	35.6	25.7	13.2	8.3
60	31.7	24.9	12.6	7.9
65	28.5	24.4	12.0	7.5
70	25.9	23.0	11.5	7.1
75	23.5	21.9	11.1	6.8
80	21.5	21.0	10.7	6.5
85	19.8	19.5	10.2	6.3
90	18.2	18.0	9.8	6.0
95	16.9	16.6	9.5	5.7
100	15.6	15.4	9.2	5.5
105	14.5	14.3	8.7	5.3
110	13.6	13.3	8.3	5.2
115	12.6	12.4	8.0	4.9
120	11.8	11.6	7.7	4.7
125	11.1	10.8	7.4	4.4
130	10.4	10.1	7.2	4.3
135	9.7	9.5	7.0	4.1
140	9.1	8.9	6.8	4.0
150	8.0	7.8	6.4	3.6
155	7.6	7.3	6.3	3.5
160	7.1	6.9	6.1	3.4
200		4.1	3.7	2.7
225			2.5	2.1
235			2.0	

Main boom length 146 ft

Capacities in 1000 lbs
71,200 lbs counterweight and 33,100 lbs carbody counterweight

Radius (ft)	Boom length in (ft)			
	203	223	243	272
	lbs	lbs	lbs	lbs
19.8	37.8			
20	37.8			
25	37.3	29.6	22.1	15.7
30	36.7	28.6	21.3	13.8
35	36.2	27.6	20.8	13.0
40	35.6	26.8	19.9	12.5
45	34.6	24.7	19.2	12.0
50	34.0	24.0	17.5	11.6
55	32.8	23.3	16.1	11.0
60	30.9	22.1	15.3	10.5
65	27.7	21.2	14.8	10.1
70	25.1	20.4	14.5	9.7
75	22.7	19.5	14.2	9.3
80	20.7	18.7	13.8	9.0
85	19.0	18.0	13.4	8.7
90	17.4	17.2	13.1	8.3
95	16.0	15.9	12.8	7.9
100	14.8	14.6	12.5	7.6
105	13.7	13.5	12.1	7.3
110	12.7	12.5	11.7	7.1
115	11.8	11.6	11.4	6.8
120	11.0	10.8	10.7	6.5
130	9.5	9.3	9.2	6.0
140	8.3	8.1	8.0	5.6
150	7.2	7.0	6.9	5.3
160	6.3	6.1	6.0	5.0
170	5.5	5.3	5.2	4.7
180	4.7	4.6	4.5	4.0
190	4.1	3.9	3.8	3.4
200	3.5	3.3	3.2	2.8
215		2.5	2.4	2.0
220			2.2	

Above lift chart is for reference only. For actual lift duty please refer to lift chart in operator's cab or manual.

L – boom configuration with 146 ft main boom (No. 1311.xx / No. 1008.xx)

Configuration for L – boom lengths (203 ft – 272 ft)

	Length	Amount of boom and luffing jib extensions							
Boom foot	18 ft	1	1	1	1	1	1	1	1
Boom insert	10 ft*	1	1	1	1	1	1	1	1
Boom insert	20 ft*	2	2	2	2	2	2	2	2
Boom insert	40 ft*	2	2	2	2	2	2	2	2
Tapered	40 ft*	1	1	1	1	1	1	1	1
Luffing insert	10 ft*		1		1		1		1
Luffing insert	20 ft*			1	1			1	1
Luffing insert	40 ft*					1	1	1	1
Luffing jib head	18 ft	1	1	1	1	1	1	1	1
Max. L – boom length (ft)		203	213	223	233	243	253	262	272

*Actual lengths of boom sections are metric (e.g. 3 m, 6 m, 12 m). The figures shown above are approximate conversions to feet.

Working range - luffing jib (No. 1008.xx) 78° - 15°

Main boom 88° - 45°

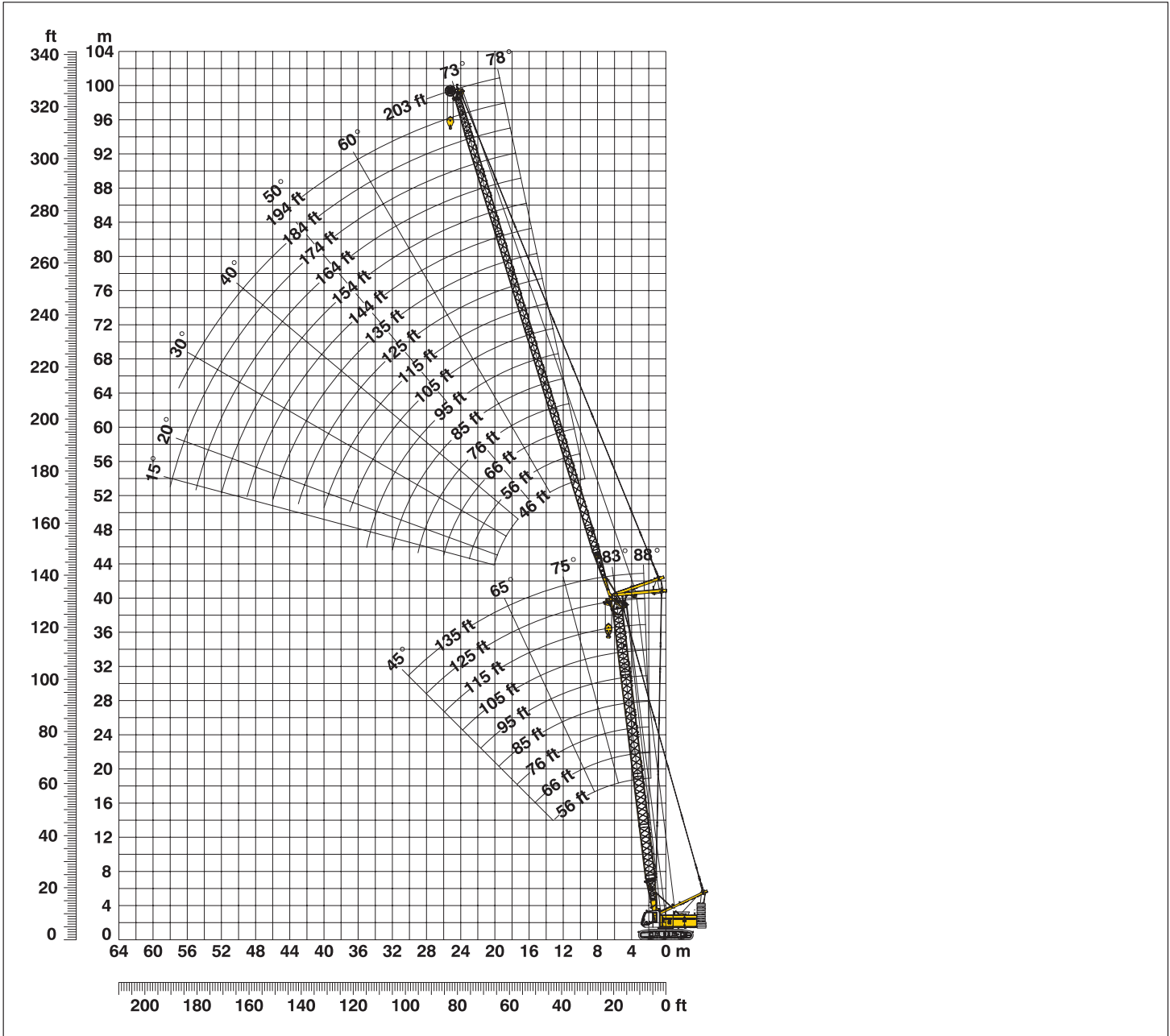

Boom configuration for main boom lengths (56 ft - 135 ft) – see table 1 on page 12

Jib configuration for jib lengths (46 ft - 203 ft)

	Length	Amount of luffing jib extensions																		
		18 ft	20 ft*	40 ft*	56 ft	66 ft	76 ft	85 ft	95 ft	105 ft	115 ft	125 ft	135 ft	144 ft	154 ft	164 ft	174 ft	184 ft	194 ft	203 ft
Luffing jib foot	18 ft	1	1	1	1	1	1	1	1	1	1	1	1	1	1	1	1	1	1	1
Luffing jib insert	10 ft*	1		1			1		1				1			1			1	
Luffing jib insert	20 ft*		1	1			1		1			1			1			1		2
Luffing jib insert	40 ft*				1	1	1		1	2	2	2	2	3	3	3	3	3	3	3
Luffing jib head	18 ft	1	1	1	1	1	1	1	1	1	1	1	1	1	1	1	1	1	1	1
Luffing jib length in (ft)		46	56	66	76	85	95	105	115	125	135	144	154	164	174	184	194	203		

*Actual lengths of boom sections are metric (e.g. 3 m, 6 m, 12 m). The figures shown above are approximate conversions to feet.

Lift chart – tower crane (No. 1008.xx)

Main boom angle 88°

Main boom 56 ft

Radius (ft)	Jib length in (ft)							
	46	75	95	115	144	164	184	203
19.4	104.9							
30	85.4	68.2	48.6					
35	69.7	64.0	47.3	35.5				
40	58.7	58.6	45.6	35.0	22.2			
45	50.5	50.5	44.0	34.6	18.3	16.6		
50	44.2	44.3	41.9	34.2	18.3	14.6	11.3	
55		39.4	39.2	33.4	18.1	14.4	11.1	8.2
80		23.8	24.7	24.5	18.7	13.1	9.8	7.0
95			19.9	19.7	17.7	12.4	9.2	6.4
115				15.3	14.9	11.6	8.5	5.7
120					14.1	11.5	8.4	5.5
145					10.8	10.5	7.8	4.9
165						8.4	7.3	4.5
180							6.5	4.3
185							6.2	4.3
200								4.2

Main boom 75 ft

Radius (ft)	Jib length in (ft)							
	46	75	95	115	144	164	184	203
20.1	102.							
30	85.5	59.3						
35	69.7	57.8	42.1	31.4				
45	50.6	50.5	40.2	30.5	20.1	15.5		
50	44.3	44.3	38.5	30.0	19.8	13.7	10.6	
55		39.4	37.4	29.5	19.5	13.6	10.4	7.8
80		21.4	21.9	24.5	17.6	12.4	9.4	6.7
100			15.9	16.8	16.6	11.6	8.7	5.9
115				13.3	14.9	11.1	8.2	5.5
140					11.3	10.5	7.6	4.9
145					10.4	10.4	7.5	4.8
165						8.6	7.2	4.4
180							6.7	4.3
185							6.5	4.2
200								4.1
205								4.1

Main boom 95 ft

Radius (ft)	Jib length in (ft)							
	46	75	95	115	144	164	184	203
20.8	77.4							
30	71.2	47.7						
35	67.5	46.3	35.6					
40	58.7	44.8	34.8	27.1				
45	50.6	43.3	34.1	26.4	17.6			
50	44.3	41.7	33.0	26.0	17.5	13.3	10.5	
55		39.4	32.2	25.5	17.2	13.0	9.9	7.3
80		16.1	19.4	22.5	16.2	11.9	8.9	6.3
100			12.3	14.1	15.0	11.1	8.2	5.7
120				9.1	13.0	10.5	7.6	5.1
145					8.4	9.8	7.2	4.6
165						7.2	6.9	4.3
180							6.7	4.1
185							6.6	4.1
200								4.0
205								4.0

Main boom 115 ft

Radius (ft)	Jib length in (ft)							
	46	75	95	115	144	164	184	203
21.5	58.1							
30	53.8	37.8						
35	49.7	36.6	29.2					
40	46.3	35.4	28.4	22.7				
45	43.6	34.1	27.7	22.3	15.7			
50	41.2	32.9	26.8	21.8	15.5	11.4		
55	19.1	31.5	24.2	21.4	15.2	11.3	9.0	6.9
80		12.1	16.1	18.4	13.9	10.4	8.2	5.8
100			10.4	12.0	12.8	9.8	7.6	5.3
120				8.1	9.2	9.1	7.1	4.8
150					5.8	7.6	6.5	4.2
165						6.2	6.2	4.0
180							6.1	3.9
185							6.1	3.9
200								3.8
205								3.8

Main boom 125 ft

Radius (ft)	Jib length in (ft)							
	46	75	95	115	144	164	184	203
21.8	50.2							
30	47.0	34.5						
35	44.4	33.4	27.0					
40	41.2	32.3	25.1	21.1				
45	38.6	31.1	24.2	20.7	14.7			
50	36.5	30.0	23.2	20.2	14.5	11.2		
55	17.5	28.7	22.4	19.7	14.2	11.1	8.5	6.5
80		12.0	15.4	16.8	12.9	10.1	7.7	5.6
100			9.7	11.5	11.6	9.3	7.2	5.1
120				7.7	9.3	8.6	6.6	4.6
150					6.0	7.2	6.0	4.1
165						5.6	5.8	3.9
185							5.5	3.7
205								3.7

Main boom 135 ft

Radius (ft)	Jib length in (ft)					
	46	75	95	115	144	
22.2	45.2					
30	42.1	31.1				
35	39.6	30.1	23.9			
40	36.6	29.1	23.1	19.5		
45	34.1	27.9	22.2	19.1	13.8	
55	16.0	22.6	20.6	18.0	13.4	
70		15.9	18.0	16.3	12.5	
80		11.8	14.8	15.3	12.0	
90			11.4	13.6	11.3	
100			9.1	10.9	10.6	
110				8.9	10.0	
120				7.2	9.3	
130					8.7	
150					6.3	

Capacities in 1000 lbs with luffing jib (No. 1008.xx), 71,200 lbs counterweight + 33,100 lbs carbody counterweight. Above lift chart is for reference only. For actual lift duty and complete chart with all available configurations please refer to lift chart in operator's cab or manual.

Lift chart - luffing jib (No. 1008.xx)

Main boom angle 83°

Main boom 56 ft

Radius (ft)	Jib length in (ft)							
	46	75	95	115	144	164	184	203
28.3	90.0							
40	57.1	56.9						
45	49.2	49.0	46.3					
50	43.1	43.0	42.7	35.1				
55	38.2	38.2	37.9	34.6				
60		34.3	34.0	33.8	19.8			
65		31.1	30.8	30.6	19.7	14.3		
70		28.4	28.1	27.9	19.6	14.1	10.6	
75		26.1	25.9	25.6	19.1	13.9	10.4	7.8
85		22.3	22.1	21.9	18.5	13.3	9.9	7.0
100			18.0	17.8	17.3	12.5	9.3	6.3
120				14.0	13.5	11.7	8.6	5.7
150					9.8	9.5	7.9	4.9
170						7.8	7.4	4.5
190							6.1	4.3
205								4.2

Main boom 75 ft

Radius (ft)	Jib length in (ft)							
	46	75	95	115	144	164	184	203
30.7	79.7							
40	56.5	56.2						
50	42.6	42.4	41.4					
55	37.8	37.7	37.4	31.1				
60		33.9	33.6	30.8	20.0			
70		28.0	27.8	27.5	18.4	13.3		
75		25.8	25.5	25.3	18.2	13.1	9.9	
80		23.8	23.6	23.3	17.9	12.8	9.7	7.0
85		22.0	21.8	21.6	17.7	12.5	9.5	6.7
105			16.6	16.4	16.0	11.7	8.8	6.0
125				13.0	12.6	11.0	8.2	5.4
150					9.6	9.3	7.6	4.8
170						7.6	7.3	4.4
190							6.0	4.3
200								4.2
210								4.2

Main boom 95 ft

Radius (ft)	Jib length in (ft)							
	46	75	95	115	144	164	184	203
33.1	71.1							
45	48.0	47.7						
50	42.1	41.8	35.9					
55	37.4	37.2	35.3	27.3				
60	33.5	33.4	33.1	26.9				
65		30.3	29.9	26.3	17.2			
70		27.6	27.3	26.0	17.1	12.8		
75		21.7	25.1	24.8	16.9	12.5	9.3	
90		16.5	18.3	19.7	16.5	11.9	8.9	6.3
105			13.2	15.7	15.6	11.4	8.4	5.8
125				10.0	12.0	10.7	7.8	5.3
155					7.9	8.7	7.2	4.6
175						6.6	6.8	4.3
195							5.5	4.1
210								4.1

Main boom 115 ft

Radius (ft)	Jib length in (ft)							
	46	75	95	115	144	164	184	203
35.5	56.8							
45	47.3	37.7						
50	41.5	36.8	29.2					
60	33.0	32.8	28.1	22.2				
65	20.7	29.8	27.5	21.8	15.7			
70		27.2	26.8	21.4	15.0	12.1		
80		15.9	16.3	19.3	14.6	11.0	8.3	
85		14.4	14.4	16.3	14.4	10.9	8.2	6.0
90		13.4	13.1	13.8	14.3	10.7	8.2	5.9
110			9.9	9.5	13.4	10.2	7.6	5.3
130				7.8	8.3	9.1	7.2	4.9
160					5.5	5.7	6.6	4.3
175						4.9	6.2	4.1
195							4.3	3.9
215								3.9

Main boom 125 ft

Radius (ft)	Jib length in (ft)							
	46	75	95	115	144	164	184	203
36.7	49.6							
50	41.1	33.5						
55	36.5	32.5	25.6					
60	32.8	31.5	25.1	20.6				
65	29.6	29.5	24.2	20.2				
70		26.9	23.3	19.8	14.0			
75		18.2	19.8	19.4	13.8	10.7		
80		15.5	16.8	18.7	13.6	10.5	8.0	
85		13.5	14.8	16.5	13.4	10.3	7.9	5.8
95		11.5	11.6	13.3	13.1	10.1	7.6	5.5
110			9.2	9.4	12.3	9.7	7.3	5.1
160					5.3	5.0	6.3	4.2
180						4.2	5.6	3.9
200							3.8	3.8
215								3.8

Main boom 135 ft

Radius (ft)	Jib length in (ft)							
	46	75	95	115	144			
37.9	43.8							
50	39.3	30.1						
55	36.2	29.2	23.5					
60	32.5	28.4	22.9	18.9				
65	29.3	27.3	22.2	18.6				
70		21.6	21.6	18.2	13.1			
80		15.3	16.9	17.5	12.8			
90		11.5	13.2	15.1	12.4			
95		10.7	11.4	14.2	12.2			
100			9.9	12.8	11.9			
110			8.5	9.5	11.4			
120				7.3	10.3			
130				6.5	8.4			
140					6.8			
160					5.2			

Capacities in 1000 lbs with luffing jib (No. 1008.xx), 71,200 lbs counterweight + 33,100 lbs carbody counterweight. Above lift chart is for reference only. For actual lift duty and complete chart with all available configurations please refer to lift chart in operator's cab or manual.

Lift chart - luffing jib (No. 1008.xx)

Main boom angle 75°

Main boom 56 ft

Radius (ft)	Jib length in (ft)							
	46	75	95	115	144	164	184	203
42.1								
55	36.6	36.3						
65	29.6	29.6	29.2					
75		24.8	24.5	24.2				
85		21.2	20.9	20.6	18.8			
95		18.4	18.2	17.9	17.3	13.1		
105			16.0	15.7	15.2	12.6	9.3	
110			15.0	14.8	14.2	12.4	9.2	6.2
130				11.7	11.3	11.0	8.5	5.6
140					10.1	9.8	8.2	5.3
160					8.2	7.9	7.6	4.8
180						6.5	6.1	4.5
190							5.5	4.4
195							5.2	4.3
200								4.3
215								3.9

Main boom 75 ft

Radius (ft)	Jib length in (ft)							
	46	75	95	115	144	164	184	203
47.2	42.9							
60	31.8	31.5						
65	28.8	28.5						
70		26.1	25.7					
80		22.1	21.7	21.4				
90		19.0	18.7	18.4	17.6			
95		17.8	17.5	17.2	16.6			
100			16.4	16.1	15.5	12.4		
110			14.4	14.2	13.6	12.1	8.9	
115			13.6	13.3	12.8	11.9	8.7	6.0
135				10.6	10.1	9.8	8.1	5.4
140					9.6	9.3	8.0	5.2
160					7.8	7.5	7.1	4.8
180						6.1	5.7	4.4
200							4.6	4.2
220								3.4

Main boom 95 ft

Radius (ft)	Jib length in (ft)							
	46	75	95	115	144	164	184	203
52.3	36.4							
65	27.8	27.4						
75	23.2	23.0	22.5					
85		19.6	19.3	18.9				
95		17.0	16.7	16.4	15.7			
100		15.9	15.6	15.3	14.7			
105			14.6	14.3	13.7	11.6		
115			13.0	12.7	12.1	11.3	8.3	
120			12.2	11.9	11.4	11.0	8.2	5.9
140				9.6	9.0	8.7	7.7	5.2
170					6.6	6.3	5.9	4.5
190						5.1	4.7	4.2
205							4.0	3.6
225								2.8

Main boom 115 ft

Radius (ft)	Jib length in (ft)							
	46	75	95	115	144	164	184	203
57.4	31.1							
70	24.3	23.8						
80	20.5	20.2	19.8					
90		17.4	17.0	16.7				
100		15.2	14.8	14.5	13.8			
105		14.2	13.9	13.6	12.9			
110			13.1	12.7	12.1	10.4		
120			11.6	11.3	10.7	10.2	7.6	
125			10.9	10.7	10.1	9.6	7.4	5.5
145				8.5	8.0	7.7	7.0	4.9
175					5.8	5.5	5.0	4.3
190						4.6	4.3	3.6
210							3.4	2.9
230								2.2

Main boom 125 ft

Radius (ft)	Jib length in (ft)							
	46	75	95	115	144	164	184	203
59.9	28.8							
75	21.8	21.3						
80	20.1	19.7						
85		18.2	17.8					
90		17.0	16.5	16.1				
105		13.9	13.5	13.2	12.3			
110		13.0	12.7	12.3	11.6	10.5		
120			11.3	10.9	10.3	9.6	7.2	
130			10.0	9.7	9.1	8.5	7.0	4.9
150				7.8	7.3	6.8	6.1	4.6
175					5.5	5.2	4.6	3.9
195						4.2	3.7	3.0
215							2.9	2.3
225								2.0

Main boom 135 ft

Radius (ft)	Jib length in (ft)				
	46	75	95	115	144
62.4	26.6				
75	21.2	20.7			
85	18.0	17.7	17.2		
95		15.3	14.9	14.5	
105		13.4	13.1	12.7	11.6
110		12.6	12.3	11.9	10.9
115			11.5	11.2	10.3
120			10.9	10.6	9.7
125			10.3	9.9	9.1
130			9.7	9.4	8.6
140				8.4	7.8
150				7.5	7.0
160					6.2
180					5.0

Capacities in 1000 lbs with luffing jib (No. 1008.xx), 71,200 lbs counterweight + 33,100 lbs carbody counterweight. Above lift chart is for reference only. For actual lift duty and complete chart with all available configurations please refer to lift chart in operator's cab or manual.

Lift chart - luffing jib (No. 1008.xx)

Main boom angle 65°

Main boom 56 ft

Radius (ft)	Jib length in (ft)							
	46	75	95	115	144	164	184	203
58.2	32.2							
75	23.4							
80		21.4						
90		18.5	18.1					
100		16.1	15.8	15.5				
115			13.1	12.8	12.2			
120			12.4	12.1	11.5			
130				10.8	10.3	9.9		
140				9.7	9.2	8.8	8.3	
170					6.7	6.4	6.0	4.7
190						5.2	4.8	4.4
205							4.1	3.7
220								3.1
225								2.9

Main boom 75 ft

Radius (ft)	Jib length in (ft)							
	46	75	95	115	144	164	184	203
66.5	25.7							
80	20.4							
85		18.5						
95		16.1	15.6					
110			13.2	12.9	12.6			
125				10.8	10.5	9.9		
130				10.2	9.9	9.3		
135					9.4	8.8	8.4	
150					8.0	7.4	7.1	6.7
160						6.7	6.3	5.9
175							5.4	5.0
195							4.3	3.9
215								3.1
230								2.1

Main boom 95 ft

Radius (ft)	Jib length in (ft)							
	46	75	95	115	144	164	184	203
74.9	20.6							
90	16.2							
95		14.8						
105		12.9	12.5					
115		11.4	11.1	10.6				
120		10.7	10.4	10.1				
135			8.8	8.5	7.8			
145				7.6	6.9	6.5		
155				6.8	6.2	5.8	5.2	
170					5.2	4.9	4.3	3.6
185					4.4	4.1	3.6	2.9
205						3.2	2.8	2.2
210							2.6	
220							2.2	

Main boom 115 ft

Radius (ft)	Jib length in (ft)							
	46	75	95	115	144	164	184	203
83.2	16.5							
95	13.9							
105		11.8						
115		10.4	9.9					
125		9.2	8.8	8.4				
140			7.4	7.1	6.3			
145				7.0	6.7	5.9		
155					6.0	5.3	4.6	
165					5.3	4.7	4.1	3.4
175						4.2	3.6	2.9
190							3.5	3.0
195								2.8
200								2.7
210								2.3

Main boom 125 ft

Radius (ft)	Jib length in (ft)						
	46	75	95	115	144	164	184
87.3	14.8						
100	12.3						
105		11.0					
120		9.2	8.7				
130		8.1	7.8	7.4			
145			6.5	6.2	5.2		
150			6.1	5.8	4.9		
160				5.2	4.4	3.7	
170				4.6	3.9	3.2	2.5
180					3.5	2.8	2.1
190					3.1	2.5	
200					2.7	2.1	

Main boom 135 ft

Radius (ft)	Jib length in (ft)				
	46	75	95	115	144
91.5	13.1				
105	10.9				
110		9.7			
120		8.6	8.1		
135		7.1	6.8	6.3	
140			6.4	6.0	
150			5.7	5.3	4.1
160				4.7	3.7
170				4.2	3.2
180					2.8
190					2.5
200					2.2

Capacities in 1000 lbs with luffing jib (No. 1008.xx), 71,200 lbs counterweight + 33,100 lbs carbody counterweight. Above lift chart is for reference only. For actual lift duty and complete chart with all available configurations please refer to lift chart in operator's cab or manual.

Lift chart – luffing jib (No. 1008.xx)

Main boom angle 45°

Main boom 56 ft

Radius (ft)	Jib length in (ft)							
	46	75	95	115	144	164	184	203
85.1	17.7							
90	16.5							
110		12.3						
115		11.6						
130			9.5					
135			8.9					
145				7.7				
155				6.9				
170					5.4			
185					4.5	4.2		
200						3.5	3.1	
210							2.7	
215							2.6	2.1
220							2.4	

Main boom 75 ft

Radius (ft)	Jib length in (ft)					
	46	75	95	115	144	164
99	12.8					
100	12.6					
125		8.9				
130		8.4				
140			7.1			
150			6.4			
160				5.4		
165				5.1		
170				4.8		
180					3.6	
190					3.2	
200					2.8	2.5
205						2.3
210						2.1

Main boom 95 ft

Radius (ft)	Jib length in (ft)			
	46	75	95	115
113	9.0			
115	8.8			
140		6.1		
145		5.7		
155			4.7	
165			4.1	
170				3.5
180				3.1

Main boom 115 ft

Radius (ft)	Jib length in (ft)		
	46	75	95
126.9	6.0		
130	5.8		
155		3.8	
160		3.5	
170			2.6
175			2.5
180			2.3

Capacities in 1000 lbs with luffing jib (No. 1008.xx), 71,200 lbs counterweight + 33,100 lbs carbody counterweight. Above lift chart is for reference only. For actual lift duty and complete chart with all available configurations please refer to lift chart in operator's cab or manual.

Working range - luffing jib (No. 1309.xx) 78° - 15°

Main boom 88° - 45°

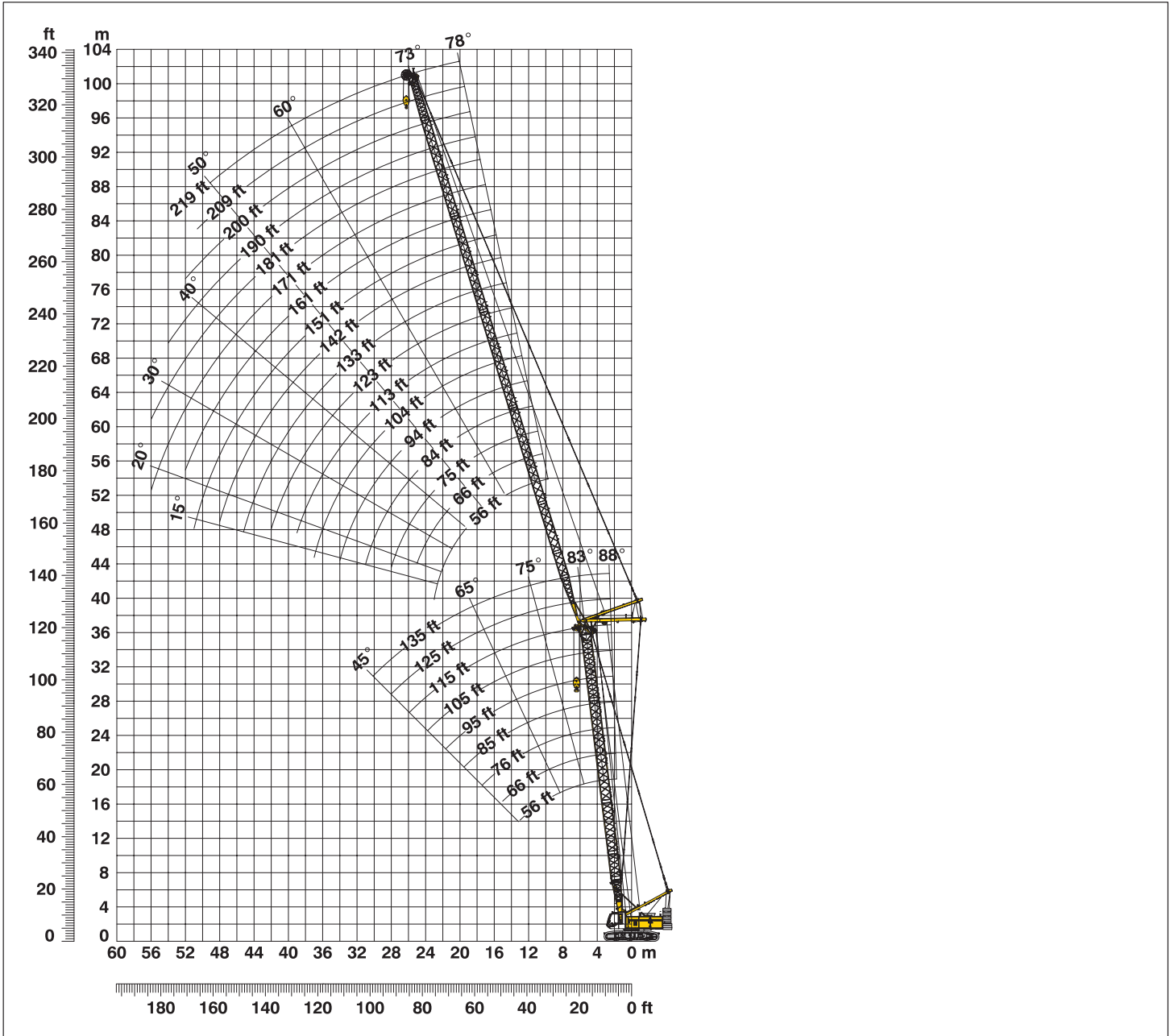

Boom configuration for main boom lengths (56 ft - 135 ft) – see table 1 on page 12
Jib configuration for jib lengths (56 ft - 219 ft)

	Length	Amount of luffing jib extensions																		
		56	66	75	84	94	104	113	123	133	142	151	161	171	181	190	200	209	219	
Luffing jib foot	18 ft	1	1	1	1	1	1	1	1	1	1	1	1	1	1	1	1	1	1	1
Luffing jib insert	10 ft*		1		1		1		1		1		1		1		1		1	
Luffing jib insert	20 ft*	1	1			1	1			1	1			1	1				1	1
Luffing jib insert	38 ft*			1	1	1	1	2	2	2	2	3	3	3	3	4	4	4	4	4
Luffing jib head	18 ft	1	1	1	1	1	1	1	1	1	1	1	1	1	1	1	1	1	1	1
Luffing jib length (ft)		56	66	75	84	94	104	113	123	133	142	151	161	171	181	190	200	209	219	

*Actual lengths of boom sections are metric (e.g. 3 m, 6 m, 11.7 m). The figures shown above are approximate conversions to feet.

Lift chart – tower crane (No. 1309.xx)

Main boom angle 88°

Main boom 56 ft

Radius (ft)	Jib length in (ft)							
	56	74	94	113	151	171	190	219
21.5	104.9							
30	85.9	84.5	72.4					
35	70.0	69.9	68.2	55.8				
45	50.8	50.7	50.4	50.1	34.1			
50	44.5	44.4	44.1	43.9	33.7	27.2	22.2	
60	35.4	35.4	35.2	34.9	33.0	25.5	21.2	15.3
75		26.8	26.6	26.4	25.8	25.1	20.1	14.2
95			19.7	19.5	18.9	18.5	18.1	13.1
115				15.1	14.5	14.2	13.8	12.3
140					10.9	10.5	10.2	9.6
150					9.8	9.4	9.1	8.5
170						7.6	7.3	6.7
180							6.6	6.0
190							5.9	5.3
200								4.7
215								3.9

Main boom 75 ft

Radius (ft)	Jib length in (ft)							
	56	74	94	113	151	171	190	219
22.1	96.4							
30	85.9	71.7						
35	70.1	69.3	55.6	44.3				
45	50.8	50.7	50.4	42.5	28.7			
50	44.5	44.4	44.1	41.7	28.2	22.4	19.3	
60	35.4	35.4	35.2	34.9	27.3	22.0	18.5	13.8
70		29.2	29.0	28.7	25.5	21.5	18.0	13.5
80		24.7	24.6	24.3	23.7	20.8	17.4	13.0
95			19.7	19.5	18.9	18.5	16.7	12.3
115				15.1	14.5	14.1	13.8	11.5
150					9.8	9.1	9.1	8.5
170						7.6	7.3	6.7
180							6.5	6.0
190							5.9	5.3
200								4.7
215								3.9

Main boom 95 ft

Radius (ft)	Jib length in (ft)							
	56	74	94	113	151	171	190	219
22.8	71.5							
30	67.3	55.1						
35	63.7	53.0	43.4	36.1				
45	50.8	48.3	40.6	34.1	23.5			
50	44.5	44.4	38.9	33.3	23.1	19.3		
55	39.5	39.4	37.7	32.2	22.7	19.0	16.0	
60	35.4	35.4	35.1	31.2	22.3	18.7	15.8	12.1
80		24.7	24.6	24.3	20.4	17.4	14.9	11.4
100			17.3	18.2	17.6	16.0	13.8	10.7
115				15.1	14.5	14.1	13.0	10.3
150					9.7	9.4	9.1	8.4
170						7.6	7.3	6.7
180							6.5	6.0
190							5.8	5.3
200								4.7
215								3.9

Main boom 115 ft

Radius (ft)	Jib length in (ft)							
	56	74	94	113	151	171	190	219
23.5	52.5							
30	49.8	41.6						
35	47.4	40.0	33.5					
40	45.2	38.5	32.6	27.6				
45	42.9	36.9	31.8	26.9	19.0			
50	40.9	35.3	30.3	25.7	18.7	15.8		
55	39.0	33.8	29.2	25.1	18.3	15.5	13.2	
60	35.4	32.5	28.0	24.3	17.9	15.3	13.0	10.1
80		21.6	23.7	21.2	16.3	14.0	12.1	9.3
100			17.0	18.2	14.6	12.8	11.2	8.6
115				15.1	13.5	11.9	10.5	8.1
155					7.9	8.9	8.6	6.9
170						7.6	7.3	6.4
190							5.8	5.2
200								4.7
220								3.6

Main boom 125 ft

Radius (ft)	Jib length in (ft)					
	56	74	94	113	133	151
23.9	46.5					
30	44.3	36.9				
35	42.2	35.6	30.3			
40	40.3	34.3	29.2	24.6	21.0	
45	38.3	32.9	28.3	24.0	20.3	17.4
60	34.0	29.1	25.0	21.8	19.0	16.3
65	21.9	27.7	24.0	21.2	18.3	16.0
80		19.6	21.4	19.1	16.8	14.8
100			15.9	16.6	14.9	13.2
115				14.3	13.5	12.2
135					8.8	10.9
155						9.2

Main boom 135 ft

Radius (ft)	Jib length in (ft)		
	74	84	94
28.1	33.4		
35	32.0	29.4	27.2
40	31.0	28.5	26.2
50	28.5	25.8	24.3
55	27.2	25.0	23.4
60	24.6	23.7	22.6
65	22.6	22.6	21.6
70	20.8	21.1	20.9
75	19.3	19.5	20.2
80	18.0	18.1	19.3
90		14.6	18.0
100			15.4

Capacities in 1000 lbs with luffing jib (No. 1309.xx), 71,200 lbs counterweight + 33,100 lbs carbody counterweight. Above lift chart is for reference only. For actual lift duty and complete chart with all available configurations please refer to lift chart in operator's cab or manual.

Lift chart - luffing jib (No. 1309.xx)

Main boom angle 83°

Main boom 56 ft

Radius (ft)	Jib length in (ft)							
	56	74	94	113	151	171	190	219
31.2	79.2							
40	57.2	57.0						
45	49.3	49.1	48.7					
50	43.2	43.0	42.7	42.3				
60	34.4	34.3	34.0	33.7	32.9			
65	31.1	31.1	30.7	30.4	29.7	27.0		
75		26.0	25.8	25.5	24.7	24.3	19.9	
80		24.0	23.7	23.5	22.7	22.3	19.7	15.1
85		22.2	22.0	21.7	21.0	20.6	19.7	14.4
100			17.8	17.6	16.9	16.5	16.1	13.5
120				13.7	13.1	12.7	12.3	11.7
160					8.3	8.0	7.7	7.1
175						6.8	6.5	5.9
195							5.2	4.6
220								3.3

Main boom 75 ft

Radius (ft)	Jib length in (ft)							
	56	74	94	113	151	171	190	219
33.6	70.9							
40	56.5	56.2						
45	48.7	48.4	48.1					
65	30.8	30.6	30.3	30.0	28.7			
75		25.7	25.4	25.1	24.3	22.1	18.6	
85		21.9	21.7	21.4	20.6	20.2	18.2	13.2
90			20.1	19.8	19.1	18.7	17.9	13.1
100			17.5	17.3	16.6	16.2	15.8	12.8
110				15.2	14.5	14.1	13.7	12.3
120				13.5	12.8	12.4	12.0	11.2
140					10.2	9.8	9.4	8.7
160					8.2	7.8	7.5	6.9
180						6.3	6.0	5.4
200							4.7	4.2
225								3.0

Main boom 95 ft

Radius (ft)	Jib length in (ft)							
	56	74	94	113	151	171	190	219
36	63.9							
45	48.0	47.7						
50	42.1	41.8	41.4					
55	37.4	37.1	36.7	35.6				
65	30.3	30.2	29.8	29.4	24.0			
70	27.6	27.5	27.2	26.8	23.3	19.7		
80		23.3	23.0	22.7	21.9	18.9	15.9	
85		21.6	21.3	21.0	20.2	18.7	15.7	11.8
105			16.1	15.9	15.2	14.7	14.2	11.3
125				12.5	11.8	11.4	11.0	9.9
160					8.0	7.6	7.3	6.4
180						6.1	5.8	5.0
200							4.6	4.0
225								2.8

Main boom 115 ft

Radius (ft)	Jib length in (ft)							
	56	74	94	113	151	171	190	219
38.4	51.6							
45	47.2	41.4						
50	41.4	40.2	33.6					
55	36.8	36.5	32.9	27.8				
70	27.2	27.0	26.7	24.7	18.5			
75	24.3	24.9	24.5	23.9	17.9	15.2		
80		22.9	22.6	22.2	17.4	14.8	12.8	
90		19.7	19.4	19.1	16.7	14.2	12.4	9.2
110			14.9	14.6	13.9	13.2	11.6	8.7
125				12.2	11.5	11.1	10.4	8.3
165					7.3	7.0	6.6	5.5
180						5.9	5.6	4.6
200							4.4	3.6
230								2.4

Main boom 125 ft

Radius (ft)	Jib length in (ft)					
	56	74	94	113	133	151
39.6	45.4					
45	43.8	36.8				
55	36.5	34.5	29.5			
60	32.7	32.4	28.7	24.4		
65	29.6	29.4	27.8	23.8	19.7	
70	27.0	26.8	25.2	23.2	19.0	16.8
75	22.3	24.6	24.1	22.6	18.4	16.3
90		19.5	19.2	18.9	16.9	15.2
110			14.7	14.4	14.0	13.7
130				11.4	11.0	10.7
150					8.7	8.5
165						7.2

Main boom 135 ft

Radius (ft)	Jib length in (ft)		
	74	84	94
46.2	32.9		
50	32.3	29.5	
55	31.1	28.8	25.8
60	30.1	27.8	24.7
70	25.9	24.4	22.8
75	24.3	23.4	21.8
80	22.5	22.3	21.1
85	20.8	20.6	20.5
90	19.3	19.1	19.0
95	17.9	17.8	17.7
100		16.7	16.5
110			14.5

Capacities in 1000 lbs with luffing jib (No. 1309.xx), 71,200 lbs counterweight + 33,100 lbs carbody counterweight. Above lift chart is for reference only. For actual lift duty and complete chart with all available configurations please refer to lift chart in operator's cab or manual.

Lift chart – luffing jib (No. 1309.xx)

Main boom angle 75°

Main boom 56 ft

Radius (ft)	Jib length in (ft)							
	56	74	94	113	151	171	190	219
46.2	45.3							
55	36.5	36.2						
65	29.6	29.4	29.0					
75	24.8	24.7	24.3	23.9				
90		19.5	19.3	18.9	18.1			
95			17.9	17.6	16.8	16.3		
105			15.7	15.4	14.6	14.2	13.8	
110			14.7	14.5	13.7	13.3	12.9	
120				12.8	12.1	11.7	11.3	10.6
130				11.4	10.7	10.3	9.9	9.3
140					9.6	9.2	8.8	8.1
165					7.2	6.9	6.5	5.9
185						5.5	5.2	4.5
200							4.3	3.7
230								2.3

Main boom 75 ft

Radius (ft)	Jib length in (ft)							
	56	74	94	113	151	171	190	219
51.3	38.4							
60	31.7	31.3						
70	26.2	25.9	25.5					
75	24.0	23.8	23.3					
80		21.9	21.5	21.1				
95		17.5	17.2	16.9	16.0			
100			16.1	15.7	14.9	14.4		
110			14.1	13.8	13.0	12.6	12.2	
115			13.3	13.0	12.2	11.8	11.3	
125				11.5	10.8	10.3	9.9	8.8
130					10.9	10.1	9.7	9.3
170						6.4	6.1	5.7
190							4.8	4.5
205								3.7
230								2.0

Main boom 95 ft

Radius (ft)	Jib length in (ft)							
	56	74	94	113	151	171	190	219
56.4	32.8							
65	27.5	27.1						
75	23.0	22.7	22.3					
85	19.6	19.4	19.0	18.6				
100		15.7	15.3	14.9	14.0			
110			13.5	13.1	12.2	11.7		
115			12.6	12.3	11.5	11.0	10.2	
120			11.9	11.6	10.8	10.3	9.6	
130				10.3	9.5	9.0	8.4	7.1
140				9.2	8.4	8.0	7.4	6.2
175					5.6	5.2	4.9	3.7
195						4.1	3.7	2.7
200							3.5	2.5
210							3.0	2.1

Main boom 115 ft

Radius (ft)	Jib length in (ft)							
	56	74	94	113	151	171	190	219
61.5	28.2							
70	24.0	23.6						
80	20.3	20.0	19.5					
85	18.8	18.5	18.0					
90		17.2	16.7	16.3				
105		14.0	13.6	13.2	12.1			
115			12.0	11.6	10.7	9.8		
120			11.3	10.9	10.0	9.2	8.4	
125			10.6	10.3	9.4	8.6	7.8	
140				8.6	7.8	7.2	6.4	5.1
180					4.9	4.5	3.8	2.6
190						3.9	3.3	2.2
200						3.4	2.9	
215							2.4	

Main boom 125 ft

Radius (ft)	Jib length in (ft)					
	56	74	94	113	133	151
64.1	26.1					
75	21.5	21.1				
85	18.3	18.0	17.5			
90	16.9	16.7	16.2	15.8		
100		14.5	14.1	13.7	13.1	
105		13.6	13.2	12.8	12.3	11.4
110		12.7	12.3	12.0	11.5	10.7
130			9.7	9.3	8.9	8.4
145				7.8	7.4	7.0
165					5.9	5.5
170						5.2
180						4.6

Main boom 135 ft

Radius (ft)	Jib length in (ft)		
	74	84	94
74.5	20.6		
75	20.4		
80	18.8	18.5	
85	17.4	17.1	16.9
90	16.2	15.9	15.7
95	15.1	14.8	14.6
100	14.1	13.8	13.6
105	13.1	12.9	12.7
110	12.3	12.1	11.9
120		10.7	10.5
125			9.9
130			9.3

Capacities in 1000 lbs with luffing jib (No. 1309.xx), 71,200 lbs counterweight + 33,100 lbs carbody counterweight. Above lift chart is for reference only. For actual lift duty and complete chart with all available configurations please refer to lift chart in operator's cab or manual.

Lift chart - luffing jib (No. 1309.xx)

Main boom angle 65°

Main boom 56 ft

Radius (ft)	Jib length in (ft)							
	56	74	94	113	151	171	190	219
63.9	28.4							
75	23.3	22.9						
85	19.8	19.6						
90		18.2	17.8					
100		15.8	15.5	15.1				
120			12.0	11.7	10.9			
130				10.4	9.7	9.2		
135				9.9	9.1	8.6		
145					8.1	7.7	7.2	
160					6.8	6.4	6.0	5.2
175					5.7	5.4	5.0	4.2
180						5.0	4.7	4.0
195						4.2	3.8	3.2
200							3.6	2.9
210							3.1	2.5
220								2.1

Main boom 75 ft

Radius (ft)	Jib length in (ft)							
	56	74	94	113	151	171	190	219
72.2	22.8							
85	18.6	18.2						
90	17.2	16.9						
95		15.8	15.3					
105		13.8	13.4	12.9				
110		12.9	12.6	12.2				
125			10.4	10.1				
130				9.5	8.7			
140				8.5	7.7	7.2		
145				8.0	7.2	6.7		
150					6.8	6.3	5.8	
170					5.4	4.9	4.5	3.4
180					4.7	4.3	3.9	2.8
195						3.5	3.2	2.1
200						3.3	2.9	
220							2.1	

Main boom 95 ft

Radius (ft)	Jib length in (ft)						
	56	74	94	113	151	171	190
80.5	18.3						
95	14.8	14.4					
100	13.7	13.5					
105		12.6	12.1				
115		11.1	10.7	10.2			
140				7.5	6.6		
150				6.7	5.8	5.2	
155				6.3	5.5	4.9	
160					5.2	4.6	3.8
190					3.5	3.0	2.4
195						2.8	2.2
200						2.6	
210						2.2	

Main boom 115 ft

Radius (ft)	Jib length in (ft)						
	56	74	94	113	151	171	190
88.8	14.7						
100	12.6	12.1					
105	11.7	11.4					
115		10.0	9.5				
125		8.8	8.4	7.9			
145			6.6	6.2	5.0		
155				5.5	4.4	3.5	
160				5.1	4.1	3.3	
170					3.6	2.8	2.0
180					3.1	2.3	
185					2.9	2.1	
190					2.7		
200					2.3		

Main boom 125 ft

Radius (ft)	Jib length in (ft)					
	56	74	94	113	133	151
93	13.1					
105	11.1	10.7				
110	10.4	10.0				
115		9.4	8.8			
130		7.7	7.3	6.9		
140			6.5	6.0	5.3	
150			5.7	5.3	4.7	3.9
165				4.4	3.9	3.1
185					2.9	2.3
190					2.1	

Main boom 135 ft

Radius (ft)	Jib length in (ft)			
	74	84	94	
107.9	9.5			
110	9.3			
115	8.7	8.4		
120	8.2	7.9	7.6	
125	7.7	7.4	7.1	
130	7.2	6.9	6.7	
135		6.5	6.3	
140		6.1	5.9	
145			5.5	
150			5.2	

Capacities in 1000 lbs with luffing jib (No. 1309.xx), 71,200 lbs counterweight + 33,100 lbs carbody counterweight. Above lift chart is for reference only. For actual lift duty and complete chart with all available configurations please refer to lift chart in operator's cab or manual.

Lift chart – luffing jib (No. 1309.xx)

Main boom angle 45°

Main boom 56 ft

Radius (ft)	Jib length in (ft)						
	56	74	94	113	151	171	190
	lbs	lbs	lbs	lbs	lbs	lbs	lbs
93.2	15.4						
100	14.0						
110		12.0					
115		11.3					
125			9.6				
135			8.5				
140				7.7			
150				6.9			
175					4.4		
180					4.1		
190					3.6	3.2	
195						2.9	
200						2.7	
205						2.5	2.1

Main boom 75 ft

Radius (ft)	Jib length in (ft)				
	56	74	94	113	151
	lbs	lbs	lbs	lbs	lbs
107.1	11.0				
110	10.6				
125		8.5			
130		8.0			
140			6.7		
145			6.3		
150			5.9		
155				5.2	
160				4.9	
165				4.6	
170				4.3	
190					2.5
195					2.3
200					2.1

Main boom 95 ft

Radius (ft)	Jib length in (ft)			
	56	74	94	113
	lbs	lbs	lbs	lbs
121	7.5			
125	7.2			
140		5.6		
145		5.2		
155			4.2	
160			3.9	
170				3.0
180				2.5

Main boom 115 ft

Radius (ft)	Jib length in (ft)		
	56	74	94
	lbs	lbs	lbs
134.9	4.8		
135	4.8		
140	4.5		
155		3.3	
160		3.0	
170			2.1

Capacities in 1000 lbs with luffing jib (No. 1309.xx), 71,200 lbs counterweight + 33,100 lbs carbody counterweight. Above lift chart is for reference only. For actual lift duty and complete chart with all available configurations please refer to lift chart in operator's cab or manual.

Working range - fixed jib (No. 0806.xx) 15° and 30°

Main boom 88°- 30°

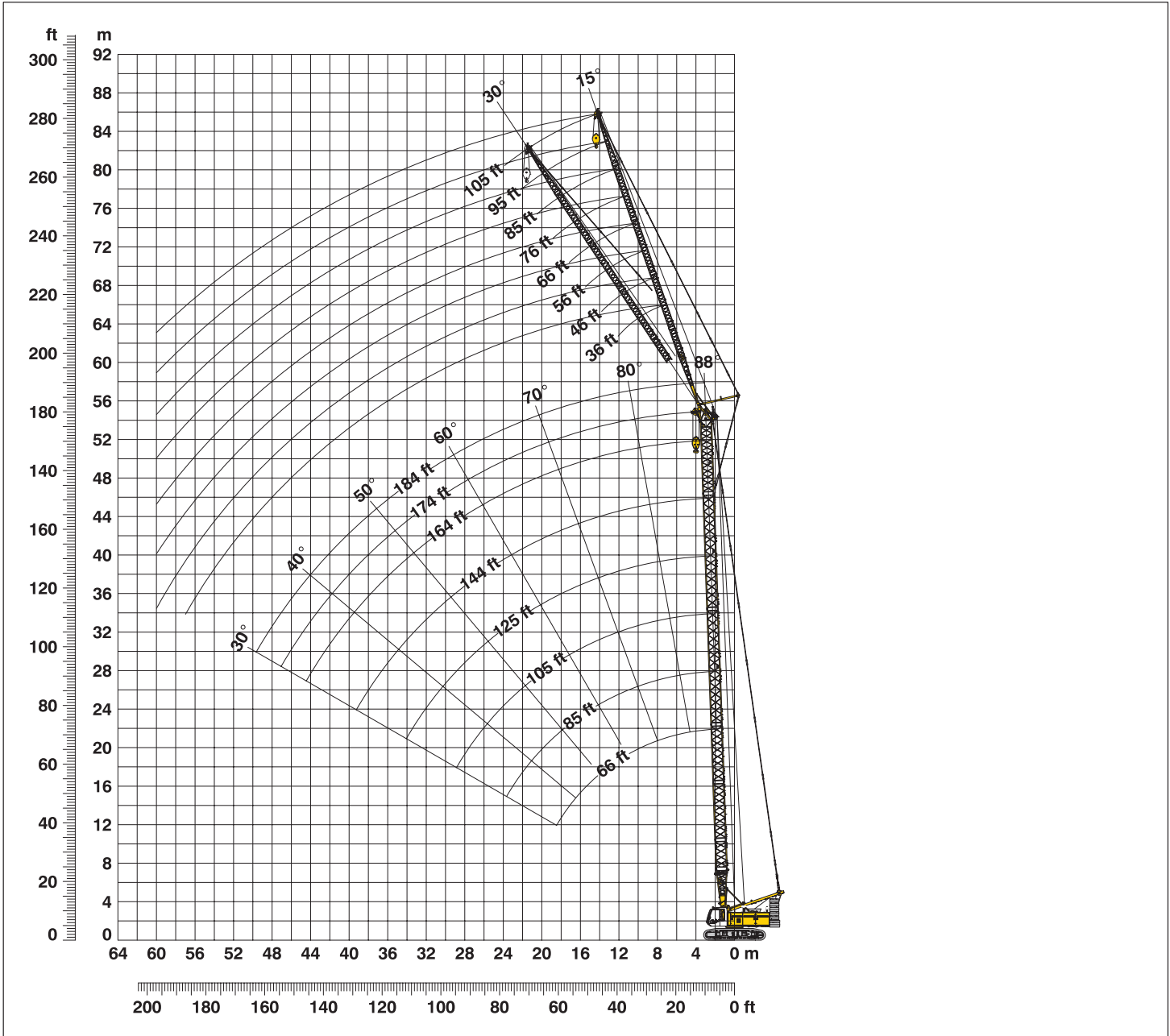

Boom configuration for boom lengths (66 ft - 184 ft) – see table 1 on page 12

Fixed jib configuration for fixed jib lengths (36 ft - 105 ft)

	Length	Amount of fixed jib extensions								
		1	1	1	1	2	2	3	1	
Fixed jib foot	18 ft	1	1	1	1	1	1	1	1	1
Fixed jib insert	10 ft*		1		1		1		1	1
Fixed jib insert	20 ft*			1	1	2	2	3	3	3
Fixed jib head	18 ft	1	1	1	1	1	1	1	1	1
Fixed jib length (ft)		11	46	56	66	76	85	95	105	

*Actual lengths of boom sections are metric (e.g. 3 m, 6 m). The figures shown above are approximate conversions to feet.

Lift chart - fixed jib (No. 0806.xx)

Offset 15°

Main boom 66 ft

Radius (ft)	Fixed jib length in (ft)			
	36	66	85	105
15.9	53.0			
30	53.0	36.3		
40	53.0	34.3	20.2	
45	47.6	33.2	19.6	12.1
50	41.5	32.2	19.1	11.7
60	32.7	30.2	18.0	11.1
70	26.6	27.6	17.0	10.5
80	22.3	23.2	15.9	10.0
95	17.5	18.4	14.8	9.4
125		12.3	12.7	8.5
145			10.0	8.1
160				8.1

Main boom 85 ft

Radius (ft)	Fixed jib length in (ft)			
	36	66	85	105
16.6	53.0			
30	53.0	34.8		
40	52.7	33.5	19.7	
45	47.2	32.7	19.3	11.9
60	32.2	30.2	18.0	11.1
80	21.8	22.8	16.3	10.1
90	18.4	19.4	15.6	9.7
100	15.8	16.7	14.9	9.3
110	13.6	14.5	14.2	9.0
140		9.8	10.2	8.3
160			8.0	7.9
180				6.6

Main boom 105 ft

Radius (ft)	Fixed jib length in (ft)			
	36	66	85	105
17.3	53.0			
30	53.0	32.2		
40	53.0	31.8	18.8	
45	46.9	31.3	18.7	12.3
60	31.8	28.6	17.6	11.0
80	21.4	22.5	16.3	10.1
100	15.4	16.3	15.0	9.4
120	11.5	12.3	12.7	8.8
130	9.9	10.7	11.1	8.5
160		7.3	7.7	8.0
180			6.0	6.3
200				4.9

Main boom 125 ft

Radius (ft)	Fixed jib length in (ft)			
	36	66	85	105
18	53.0			
30	52.9	29.7		
40	51.5	29.5	17.7	
45	46.5	29.1	17.6	11.9
80	20.9	22.0	16.0	10.0
100	14.9	15.8	15.0	9.4
120	11.0	11.8	12.2	8.8
140	8.2	9.0	9.4	8.3
145	7.6	8.4	8.8	8.2
175		5.5	5.9	6.2
195			4.4	4.8
215				3.5

Main boom 144 ft

Radius (ft)	Fixed jib length in (ft)			
	36	66	85	105
18.7	45.0			
35	43.9	27.0		
40	43.2	26.9	17.2	
50	39.9	25.3	17.0	10.9
80	20.5	21.7	15.4	9.9
100	14.5	15.4	14.4	9.2
120	10.5	11.4	11.9	8.7
140	7.8	8.5	9.0	8.3
160	5.7	6.4	6.8	7.1
190		4.0	4.4	4.7
210			3.1	3.4
230				2.4

Main boom 164 ft

Radius (ft)	Fixed jib length in (ft)			
	36	66	85	105
19.3	37.1			
35	36.1	22.3		
40	35.5	22.3	15.5	
50	34.2	21.9	15.5	10.4
60	30.5	21.4	15.2	10.2
80	20.1	19.6	14.6	9.6
120	10.0	10.9	11.4	8.6
140	7.2	8.1	8.5	8.2
180	3.5	4.2	4.6	5.0
210		2.3	2.7	3.0
220			2.1	2.4
225				2.2

Main boom 174 ft

Radius (ft)	Fixed jib length in (ft)			
	36	66	85	105
19.7	33.7			
35	32.8	20.4		
40	32.3	20.4	15.8	
50	31.4	20.2	14.7	10.1
80	19.8	18.8	14.0	9.5
120	9.8	10.7	11.2	8.5
160	4.9	5.7	6.1	6.4
180	3.3	4.0	4.4	4.7
190	2.6	3.3	3.7	4.0
210		2.1	2.4	2.7
215			2.2	2.5
220				2.2

Main boom 184 ft

Radius (ft)	Fixed jib length in (ft)			
	36	46	66	75
20	29.5			
25	29.3	25.8		
35	28.5	24.3	18.4	
40	28.1	23.9	18.2	15.7
80	19.7	20.1	16.4	14.6
120	9.6	9.9	10.5	10.8
160	4.7	5.0	5.5	5.7
180	3.1	3.4	3.8	4.0
195	2.1	2.4	2.8	3.0
200		2.0	2.5	2.7
205			2.2	2.4
210				2.1

Capacities in 1000 lbs with fixed jib (No. 0806.xx), 71,200 lbs counterweight + 33,100 lbs carbody counterweight. Above lift chart is for reference only. For actual lift duty and complete chart with all available configurations please refer to lift chart in operator's cab or manual.

Lift chart - fixed jib (No. 0806.xx)

Offset 30°

Main boom 66 ft

Radius (ft)	Fixed jib length in (ft)			
	36	66	85	105
24.5	53.0			
45	48.5	29.7		
55	37.3	27.1	17.8	
70	27.0	23.4	15.1	9.7
80	22.6	22.0	14.4	9.4
90	19.1	20.3	13.9	9.0
95	17.7	18.9	13.7	8.9
125		12.5	12.7	8.2
140			10.9	8.1
145			10.2	8.1
160				8.2
165				8.4

Main boom 85 ft

Radius (ft)	Fixed jib length in (ft)			
	36	66	85	105
25.2	53.0			
45	48.2	29.1		
60	32.9	24.4	15.2	
70	26.7	23.6	15.0	9.6
80	22.2	22.5	14.5	9.3
90	18.8	20.0	14.0	9.1
100	16.0	17.2	13.5	8.8
110	13.8	14.9	13.2	8.6
140		10.0	10.6	8.1
160			8.2	8.1
170				7.7
180				6.8

Main boom 105 ft

Radius (ft)	Fixed jib length in (ft)			
	36	66	85	105
25.9	53.0			
45	44.8	27.2		
60	32.6	23.2	15.5	
70	26.2	21.9	15.1	9.4
80	21.9	20.9	14.4	9.2
100	15.7	16.9	13.5	8.8
110	13.5	14.6	13.1	8.6
120	11.6	12.7	12.9	8.4
130	10.1	11.1	11.7	8.3
160		7.4	8.0	8.0
180			6.1	6.6
200				5.0

Main boom 125 ft

Radius (ft)	Fixed jib length in (ft)			
	36	66	85	105
26.5	46.4			
45	41.8	24.8		
60	32.3	22.4	15.0	
70	26.1	20.4	14.6	9.3
80	21.5	18.6	13.9	9.1
100	15.3	16.6	13.1	8.7
120	11.2	12.3	12.4	8.3
140	8.3	9.3	9.9	8.0
150	7.1	8.1	8.7	7.9
180		5.2	5.8	6.2
200			4.2	4.7
215				3.7

Main boom 144 ft

Radius (ft)	Fixed jib length in (ft)			
	36	66	85	105
27.2	41.4			
50	36.9	21.9		
60	32.0	19.9	14.6	
70	25.8	18.1	14.0	9.5
80	21.2	17.2	12.7	8.9
100	14.9	16.0	12.0	8.6
120	10.9	12.0	11.4	8.2
140	8.0	9.0	9.6	7.9
165	5.3	6.3	6.8	7.2
195		3.8	4.3	4.8
215			3.0	3.4
235				2.2

Main boom 164 ft

Radius (ft)	Fixed jib length in (ft)			
	36	66	85	105
27.9	34.5			
50	31.5	18.6		
60	29.6	17.0	13.3	
70	25.4	14.8	12.9	9.2
80	20.8	13.9	11.3	8.6
100	14.5	13.0	9.6	8.4
120	10.4	11.6	9.2	8.1
140	7.5	8.6	9.0	7.9
180	3.7	4.5	5.1	5.5
210		2.4	2.9	3.4
225			2.0	2.5
230				2.2

Main boom 174 ft

Radius (ft)	Fixed jib length in (ft)			
	36	66	85	105
28.3	30.7			
50	29.4	16.9		
60	27.9	16.5	12.5	
75	22.8	15.2	12.0	8.6
80	20.6	14.7	11.7	8.5
120	10.2	11.4	9.7	8.0
140	7.3	8.4	8.9	7.7
180	3.4	4.3	4.9	5.3
190	2.7	3.6	4.1	4.6
210		2.2	2.7	3.2
220			2.1	2.6
230				2.0

Main boom 184 ft

Radius (ft)	Fixed jib length in (ft)			
	36	46	66	75
28.6	26.8			
35	26.9	22.8		
50	23.9	20.9	15.4	
55	23.4	20.7	15.5	13.4
60	23.0	20.4	15.5	13.4
100	14.1	14.7	13.9	12.7
140	7.1	7.5	8.3	8.6
180	3.3	3.6	4.2	4.5
195	2.2	2.5	3.1	3.4
200		2.2	2.7	3.0
210			2.1	2.4
215				2.1

Capacities in 1000 lbs with fixed jib (No. 0806.xx), 71,200 lbs counterweight + 33,100 lbs carbody counterweight. Above lift chart is for reference only. For actual lift duty and complete chart with all available configurations please refer to lift chart in operator's cab or manual.

Notice

A large grid of graph paper, consisting of 25 columns and 45 rows of small squares, intended for taking notes or calculations.

